

ROUTE FAI 90/94	SECTION 2011-027-I	COUNTY COOK	TOTAL SHEETS 87	SHEET NUMBER 70
--------------------	-----------------------	----------------	--------------------	--------------------

CONTRACT NO. 60P27

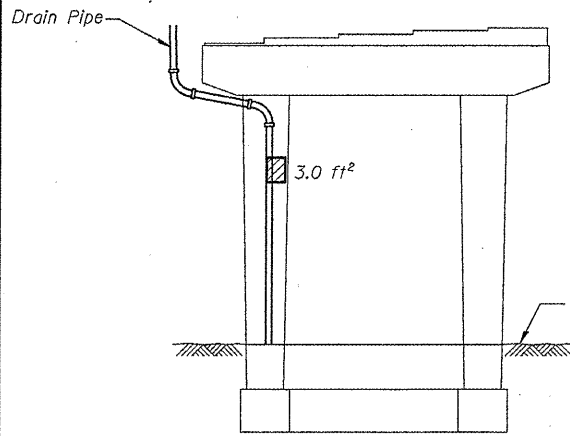

**PIER 33 - SOUTH ELEVATION**  
(Looking North)

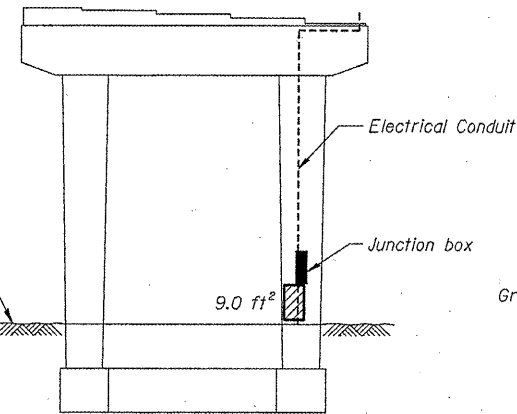

**PIER 33 - NORTH ELEVATION**  
(Looking South)

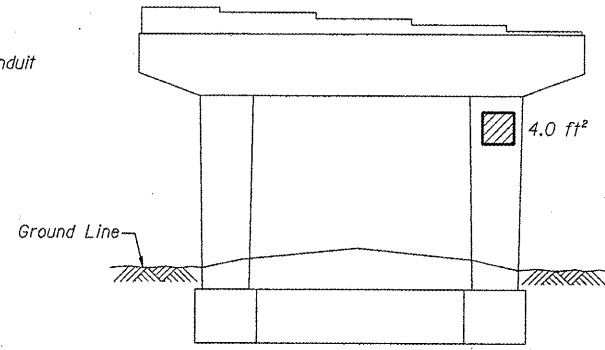

**PIER 37 - SOUTH ELEVATION**  
(Looking North)

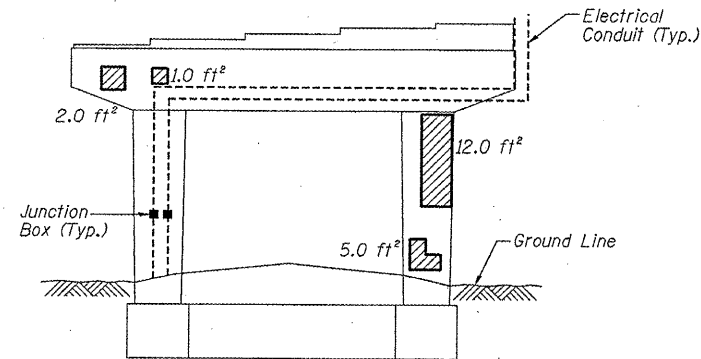

**PIER 37 - NORTH ELEVATION**  
(Looking South)

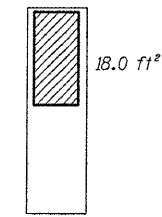

**PIER 35 - VIEW A**  
Looking East at side of column

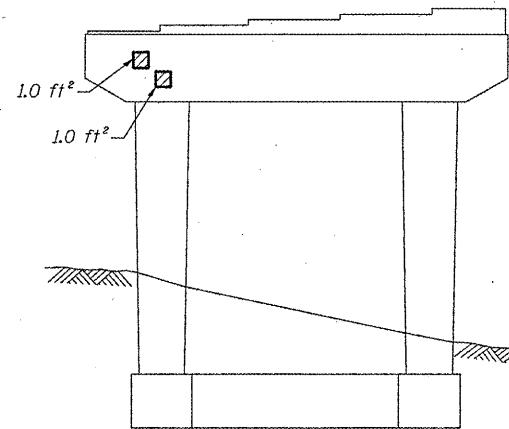

**PIER 34 - SOUTH ELEVATION**  
(Looking North)

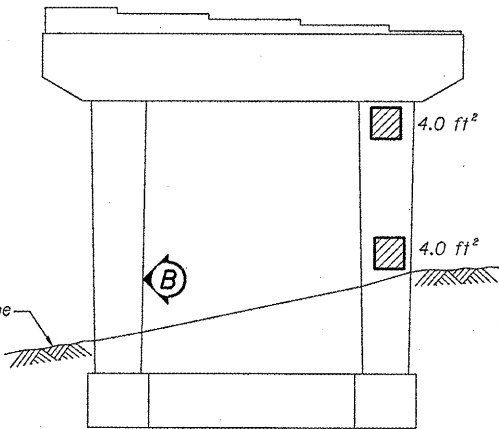

**PIER 34 - NORTH ELEVATION**  
(Looking South)

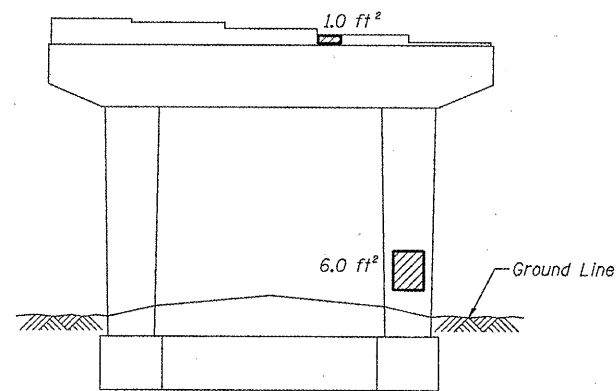

**PIER 36 - NORTH ELEVATION**  
(Looking South)

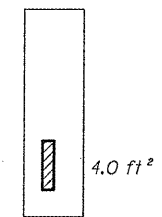

**PIER 34 - VIEW B**  
Looking East at side of column

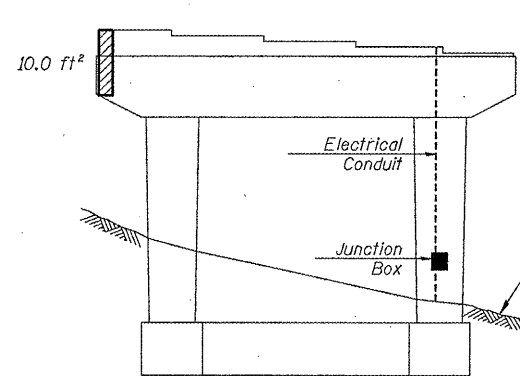

**PIER 35 - NORTH ELEVATION**  
(Looking South)

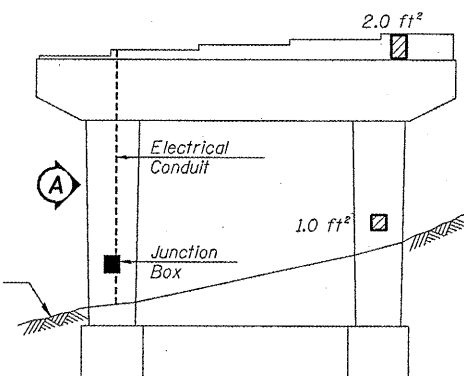

**PIER 35 - SOUTH ELEVATION**  
(Looking North)

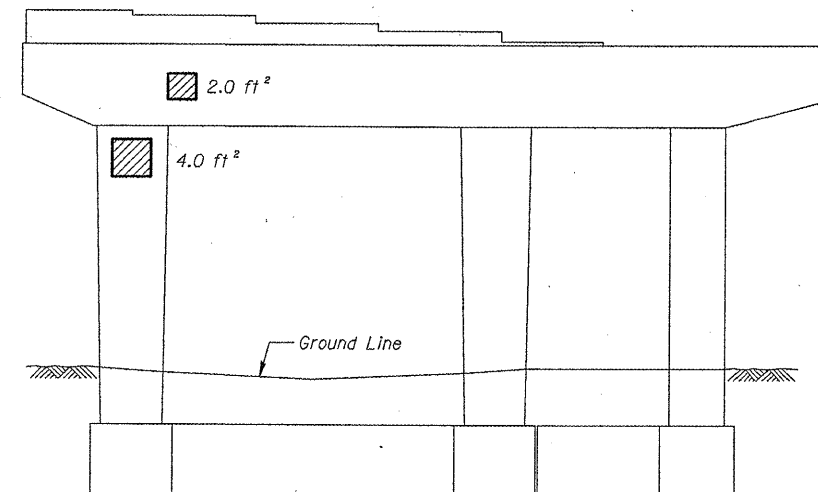

**PIER 40 - NORTH ELEVATION**  
(Looking South)

**BILL OF MATERIAL**

ITEM	UNIT	QUANTITY
Structural Repair of Concrete (Depth equal to or less than 5")	SQ. FT.	94.0

▨ - Structural Repair of Concrete (Depth equal to or less than 5")

ILLINOIS DEPARTMENT OF  
TRANSPORTATION

I-90/94 (DAN RYAN EXPRESSWAY)  
SUBSTRUCTURE REPAIRS  
SN 016-1059  
PIERS 33 - 37, & 40