

INLETS, SPECIAL

LT STA 20+38

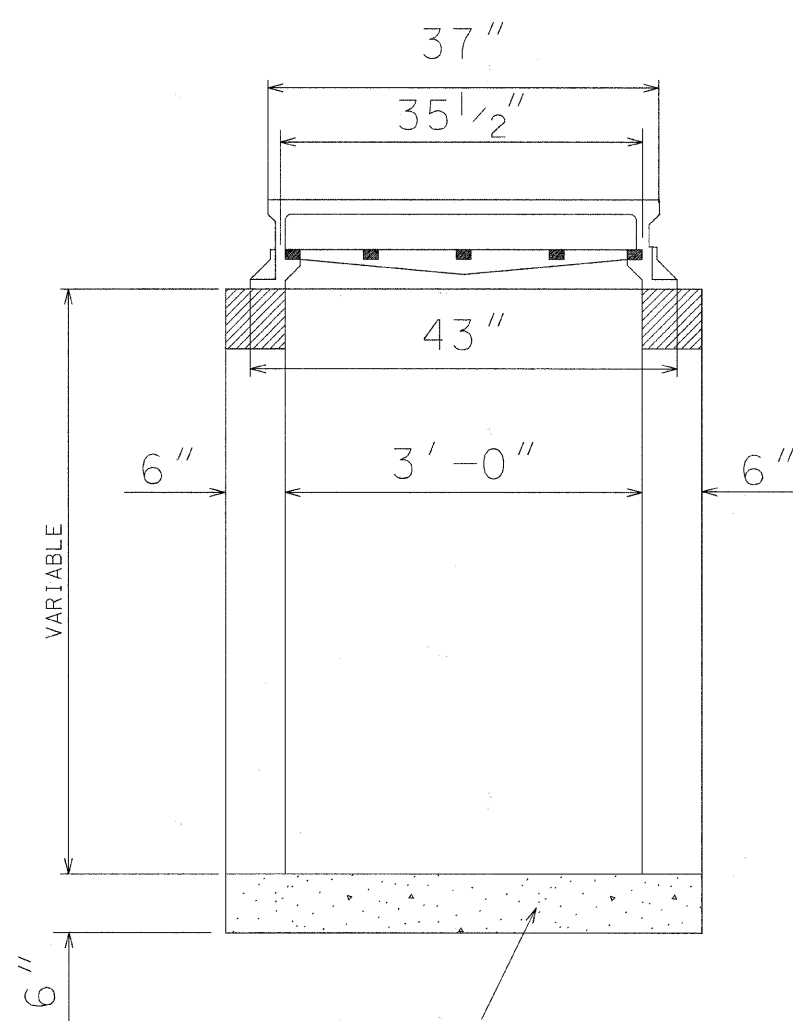

LONGITUDINAL SECTION

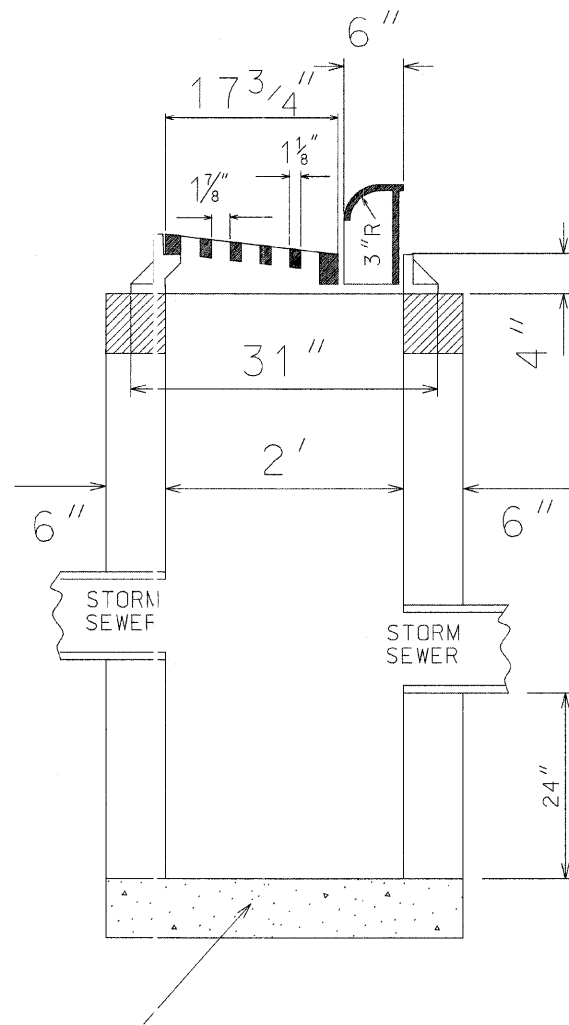

SECTION A-A

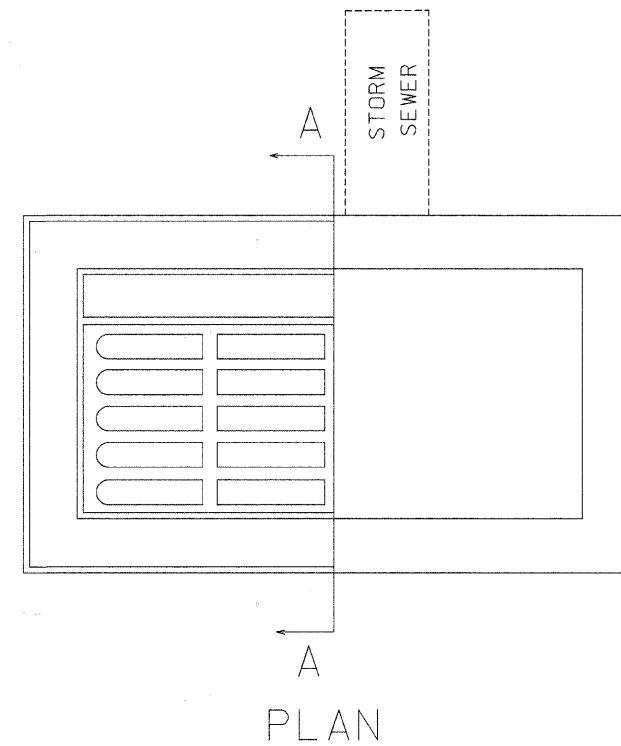

6" CLASS SI CONCRETE OR
4" PRECAST REINF. CONC.
SLAB ON 3" SAND CUSHION

NOTES:

THE INLET SHALL BE CAST IN PLACE OR PRECAST, EXCEPT AS NOTED HEREIN, AND SHALL BE CONSTRUCTED IN ACCORDANCE WITH SECTION 602 OF THE STANDARD SPECIFICATIONS. THE CONTRACT UNIT PRICE EACH FOR INLETS, SPECIAL SHALL INCLUDE THE COST OF FURNISHING AND INSTALLING THE INLET WITH SAND CUSHION IF REQUIRED. CLASS SI CONCRETE OR PRECAST CONCRETE SHALL BE USED THROUGHOUT. THE SIDEWALLS MAY BE BUILT AS PRECAST SEGMENTAL SECTIONS. THE HEIGHT OF THE BOX MAY BE CONSTRUCTED 6" SHORT TO ALLOW FOR FIELD ADJUSTMENTS. THE WALL ADJUSTMENTS SHALL BE MADE WITH CONCRETE BUILDING BRICK OR CLASS SI CONCRETE.

FRAME AND GRATE TO WEIGHT APPROXIMATELY 525 LBS.

(NEENAH R-3246 W/TYPE C GRATE OR EQUAL)

FILE NAME = S:\PROJECTS\2010\201010\BarneyDriveOverTributaryOfRockRun\InletSpecialDetail.dgn

USER NAME =	DESIGNED - L.G.N.	REVISED -
	CHECKED - G.F.S.	REVISED -
PLOT SCALE =	DRAWN - L.G.N.	REVISED -
PLOT DATE =	CHECKED - G.F.S.	REVISED -

ILLINOIS DEPARTMENT OF TRANSPORTATION
BARNEY DRIVE OVER TRIBUTARY OF ROCK RUN
STATION 20+00

INLETS, SPECIAL DETAIL
STRUCTURE NO. 099-6474

SHEET NO. 2 OF 2 SHEETS

F.A.U. RTE.	SECTION	COUNTY	TOTAL SHEETS	SHEET NO.
0330	08-00413-00-BR	WILL	33	28
WHA# 1201D10		CONTRACT NO. 63571		
ILLINOIS/FED. AID PROJECT BRW-9003162				