

PAVEMENT PATCHING FOR HOT-MIX ASPHALT SURFACED PAVEMENT

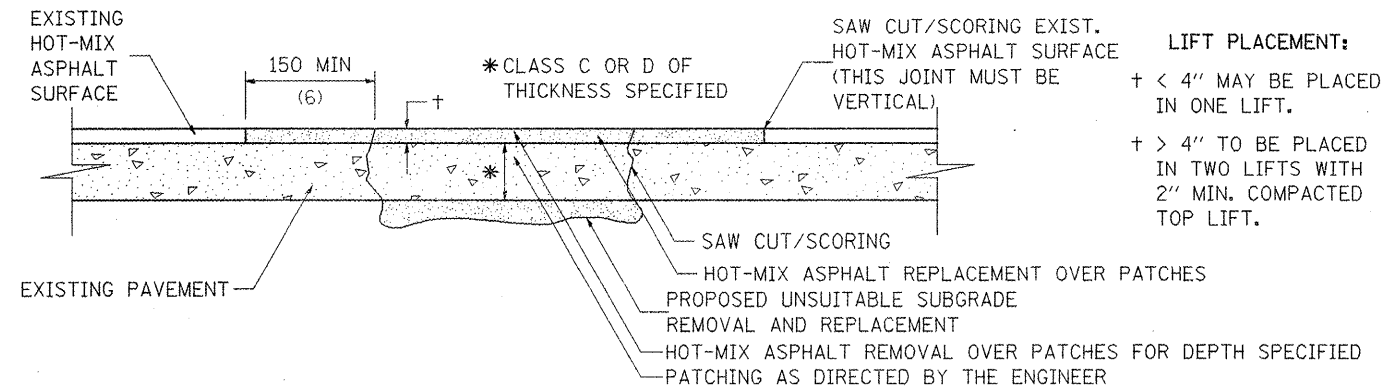

SEQUENCE OF CONSTRUCTION:

1. REMOVE THE EXISTING HOT-MIX ASPHALT SURFACE.
2. RESIDENT ENGINEER WILL DETERMINE IF LOCATION IS TO BE PATCHED OR TO ONLY REPLACE HOT-MIX ASPHALT SURFACE.
3. REMOVE AND REPLACE FULL DEPTH PATCHES AT LOCATIONS DIRECTED BY THE ENGINEER.
4. REPLACE HOT-MIX ASPHALT SURFACE OVER FULL DEPTH PATCHES AND AT LOCATIONS OF HOT-MIX ASPHALT SURFACE REMOVAL.

GENERAL NOTES:

1. FOR BASIS OF PAYMENT: SEE THE RECURRING SPECIAL PROVISION "PATCHING WITH HOT-MIX ASPHALT OVERLAY REMOVAL".

ALL DIMENSIONS ARE IN MILLIMETERS (INCHES) UNLESS OTHERWISE NOTED.

REVISED - 5-27-09

AREA NOT USED

PAVEMENT PATCHING FOR HOT-MIX ASPHALT SURFACED PAVEMENT 32.4

AREA NOT USED

REVISED -	REGION 2 / DISTRICT 2 STANDARD	F.A.P. RTE.	SECTION	COUNTY	TOTAL SHEETS	SHEET NO.
REVISED -		742	(32, 33)RS-3	WINNEBAGO	17	14
REVISED -		CONTRACT NO. 64H13				
REVISED -		SCALE: 50.0000' / 1" SHEET NO. OF SHEETS STA. TO STA.	FED. ROAD DIST. NO. ILLINOIS FED. AID PROJECT			

PLOT DATE = Thu Mar 10 09:47:02 2011