

General notes:

1. Coldmilling shall consist of two processes: Cutting with carbide teeth mounted on a rotating drum, and planing with a moldboard mounted immediately behind the cutting drum.
2. Other similar patterns will be acceptable if they consist of a smooth, flat, planed surface interspersed with a pattern of discontinuous longitudinal striations.

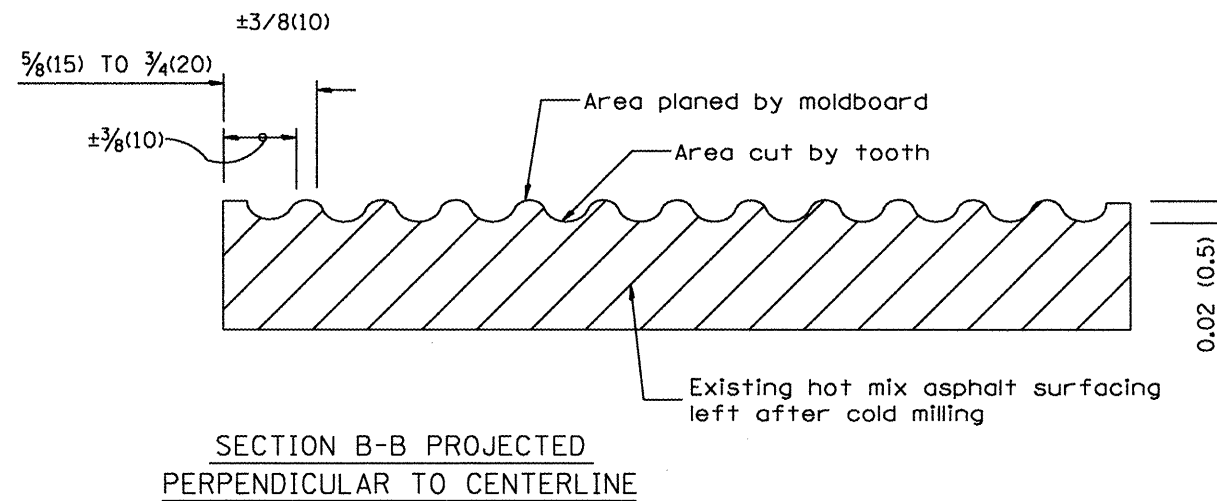
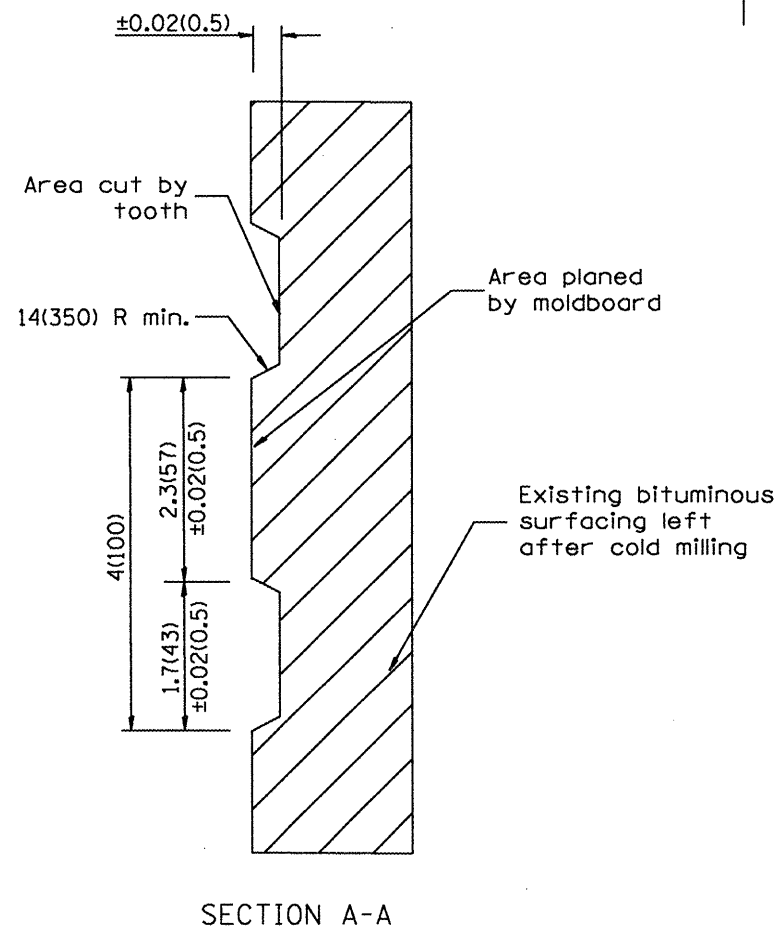

All dimensions are in inches (millimeters) unless otherwise noted.

01-01-97	BENUM_C:104.01_NEW_REVISION_BOX	I.P.
04-20-98	REMOVED MILLING DETAIL FROM STANDARD	J.A.
09-08-98	CORRECT NOTE LEADER PLACEMENT	B.W.
10-16-06	REVISED TO 2007 SPEC.	M.A.

STATE OF ILLINOIS
DEPARTMENT OF TRANSPORTATION

HOT MIX ASPHALT SURFACE REMOVAL (COLD MILLING)

NOT TO SCALE

F.A.P. RTE.	SECTION	COUNTY	TOTAL SHEETS	SHEET NO.
317	14R	PEORIA	42	37
CONTRACT NO. 68992				

CADD SID: 440001-04

FED. ROAD DIST. NO. ILLINOIS FED. AID PROJECT