

FENCE DETAIL
NOT TO SCALE

SPECIFICATIONS			
FABRIC	MESH	GAUGE	SELVAGE
ALUM.	2"	9	K+B
BARBED WIRE	TYPE 4 PT.	3 STR. ☒	6 STR. □
FRMWRK.	O.D.	WALL	LBS/LF
TOP & BOT. RAIL	1 1/8"	.140	2.27
LINE POSTS	2 3/8"	.154	3.65
BRACE RAIL	1 3/8"	.140	2.27
CORNER POSTS	2 3/8"	.203	5.79
END POSTS	2 3/8"	.203	5.79

- NOTES:
1. ALL MATERIALS SHALL BE HOT DIP GALVANIZED
 2. ALL FITTINGS SHALL BE PRESSED STEEL.

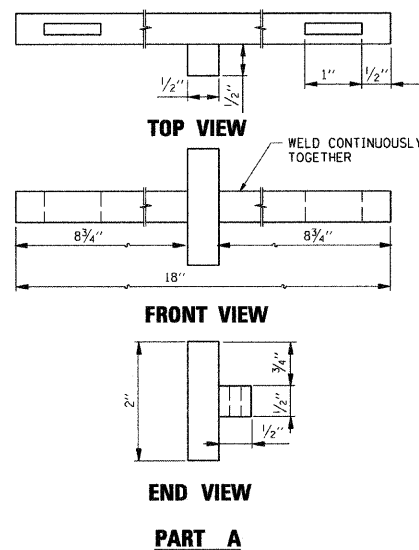

SWING GATE LOCKING DEVICE
NOT TO SCALE

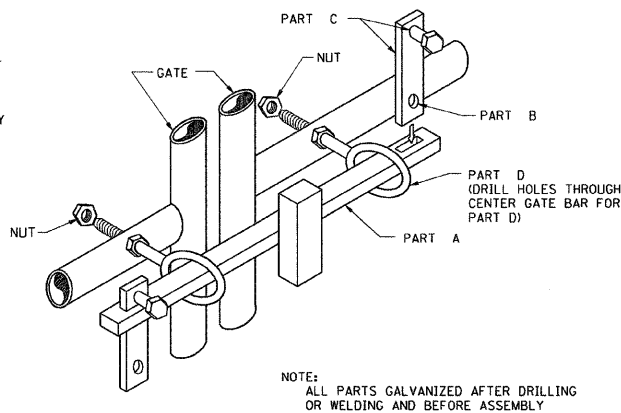

- NOTES:
ALL PARTS GALVANIZED AFTER DRILLING OR WELDING AND BEFORE ASSEMBLY

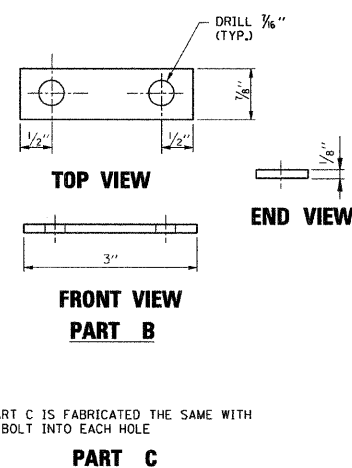

PART C

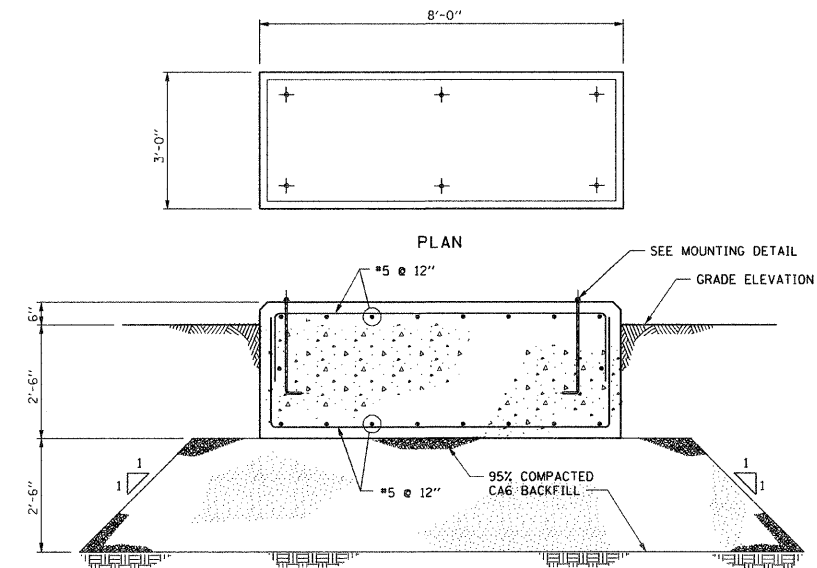

- SECTION**
1. CONCRETE PAD AS REQUIRED BY EQUIPMENT MANUFACTURER. MINIMUM OF 2 TIMES THE MASS OF EQUIPMENT SUPPORTED OR 10 TIMES THE MASS OF MOVING PARTS, WHICHEVER IS GREATER.
 2. VERIFY CONCRETE PAD DIMENSIONS WITH EQUIPMENT MANUFACTURER.
 3. STRIP APPROXIMATELY FIVE FOOT OF TOP SOIL PRIOR TO PLACING BACKFILL.

ENGINE GENERATOR FOUNDATION
NOT TO SCALE

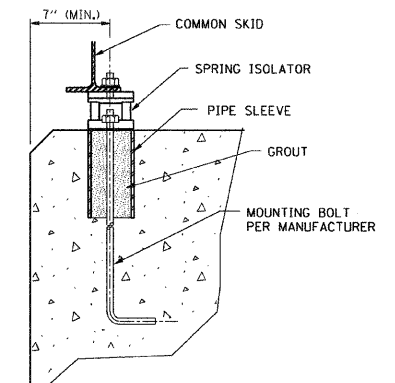

TYPICAL SPRING ISOLATOR MOUNTING DETAIL
NOT TO SCALE

G3

REVISIONS	
NAME	DATE