

GENERAL NOTES

Existing structures (including foundations, walls, cisterns, wells, or other underground structures) within the right of way shall be removed in accordance with Article 501.04 and 501.05 of the Standard Specifications, without additional compensation, unless otherwise noted in the Plans or Special Provisions.

The Contractor shall seed all disturbed areas within the project limits.

The final top four inches of soil in any right of way area disturbed by the Contractor must be a cohesive soil capable of supporting vegetation and approved by the Engineer.

No overhaul has been computed and none shall be paid for from any source.

The Contractor shall be responsible for protecting utility property during construction operations as outlined in Article 107.31 of the Standard Specifications.

All telephone and electric poles, gas pipes, etc. in the way of the improvements shall be moved by the utilities prior to construction and shall not be included in the contract. The Contractor shall notify the respective utilities to make the necessary adjustments prior to this construction.

The location and elevation of the various underground utilities as shown on the plans are not to be taken as exact. The Contractor shall use special care when conducting construction operations near them to prevent damage.

The utilities located within the project limits or immediately adjacent to the project construction limits include:

Nicor Gas	Verizon (Frontier Com.)	Corn Belt Energy
Attn: Engineering Dept.	Attn: Garrett Burt	Attn: Ian Cardosi
4651 Linden Road	112 Elm Street	1 Energy Way
Rockford, IL 61109	Sycamore, IL 60178	Bloomington, IL 61705
Ph: 815-965-0143	Ph: 815-895-1538	Ph: 800-879-0339 Ext. 304

A minimum of 48 hours advance notice is required for non-emergency work.

A Nationwide 404 Permit has been issued for this project and the conditions of that Permit must be adhered to.

Where section or subsection monuments are encountered, the Engineer shall be notified before such monuments are removed. The Contractor shall protect and carefully preserve all property markers, monuments, and right of way pins until the Owner, an Authorized Surveyor, or Agent has witnessed or otherwise referenced their location. Any property markers, section or subsection monuments unless referenced, damaged by the Contractor shall be replaced at the expense of the Contractor.

Existing mail boxes, street signs, and traffic signs that are within the construction limits shall be removed and reset by the Contractor. Cost of removing and resetting to be included in the contract unit price bid per Cubic Yard for Earth Excavation.

Where the proposed construction meets an existing bituminous surface, or where sawing is stated on the plans, the existing shall be sawed in a neat, straight line. Cost of sawing to be included in the contract unit price bid per Cubic Yard for Earth Excavation.

PAVEMENT MIXTURE REQUIREMENTS

	Surface
PG:	58-22
Design Air Voids	3.0 @ N30
Mixture Composition (Gradation Mixture)	IL 9.5
Friction Aggregate	C
Density Testing	Cores

PAVEMENT STRUCTURAL DESIGN

TR 240

Structural Design Traffic (S.D.T.) = Year 2021

Class IV Road

80,000# Truck Design

E_{RI} : 2 ksi (Poor Subgrade)

HCVs = 35

P.V. 257

S.U. 26

M.U. 9

292 ADT

USE:

3" Hot-Mix Asphalt Surface Course, Mix "C", N30 (2 - 1/2" Lifts)
12" Subbase Granular Material, Type A (4" CA-6 over 8" CA-2)

TR 240 (1925 STREET EAST) - HORIZONTAL CONTROL POINTS (NAD83-2007)					
PT #	STA.	N	E	EL.	DESCRIPTION
100	10.7' LT. 19+91.1	1682604.09	2483757.38	520.17	5/8" I.P. W/CAP
101	24.4' LT. 16+24.0	1682235.90	2483755.18	522.00	5/8" I.P. W/CAP
102	15.5' RT. 13+93.6	1682017.01	2483838.88	525.56	5/8" I.P. W/CAP
103	11.7' LT. 10+65.7	1681700.78	2483928.15	534.13	5/8" I.P. W/CAP

TR 240 (1925 STREET EAST) - VERTICAL BENCH MARKS			
PT #	STA.	ELEVATION	DESCRIPTION
400	23.2' RT. 19+80.1	520.12	RR SPIKE IN PP
401	13.6' RT. 14+56.5	525.97	CHISELED "□" ON SOUTHEAST WINGWALL
402	26.7' RT. 10+82.9	534.06	RR SPIKE IN PP W/TRANSFORMER

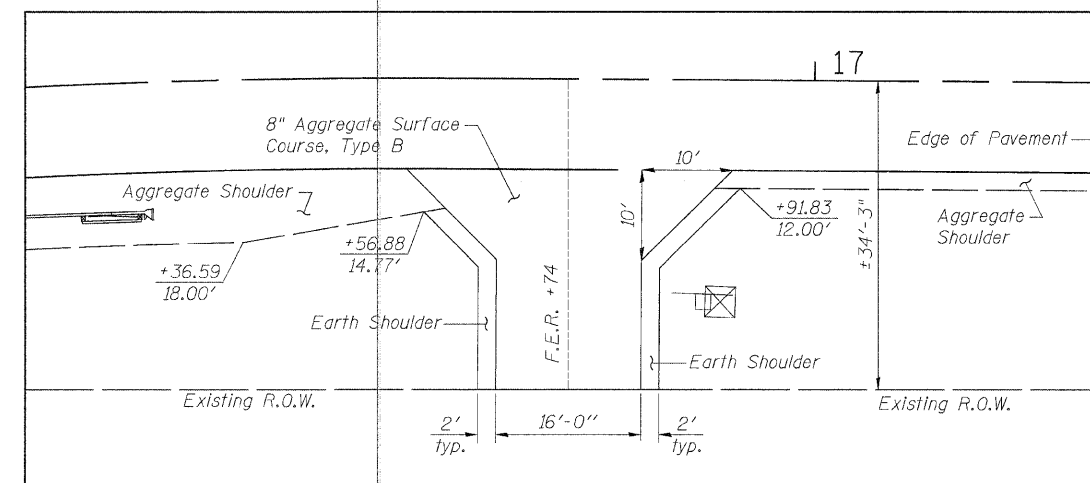
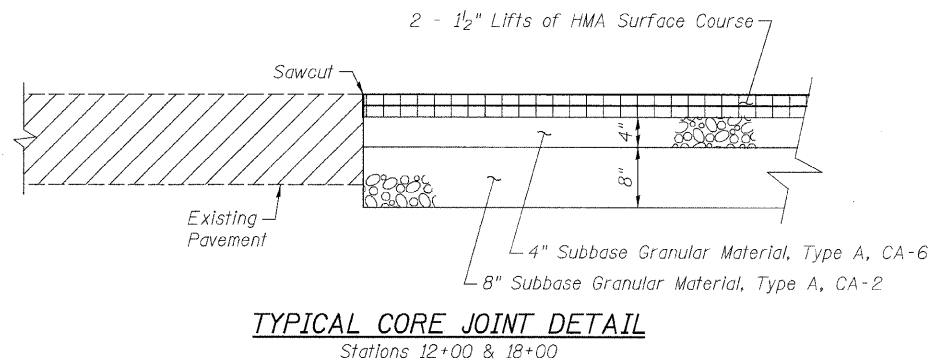

FILE NAME = S:\PROJECTS\2010\1285D10 - Bureau Co. - TR240\DESIGN\STRUCT\1285D10 - General Notes & Details.dgn

USER NAME =	DESIGNED - B.S.K.	REVISED -
PLOT SCALE =	CHECKED - B.K.C.	REVISED -
PLOT DATE =	DRAWN - R.D.A.	REVISED -
	CHECKED - B.S.K.	REVISED -

BUREAU COUNTY
TR 240 OVER PLOW HOLLOW CREEK
STATION 15 + 00

GENERAL NOTES AND DETAILS
STRUCTURE NO. 006-4012

STA. 12+00 TO STA. 18+00

TWP. RTE.	SECTION	COUNTY	TOTAL SHEETS	SHEET NO.
240	10-01121-00-BR	BUREAU	23	4
WHA* 1285D10		CONTRACT NO. 87483		
ILLINOIS FED. AID PROJECT BROS-0011(075)				