

L
4-1 **CONCRETE SIDEWALK AND BORDERS**
NOT TO SCALE

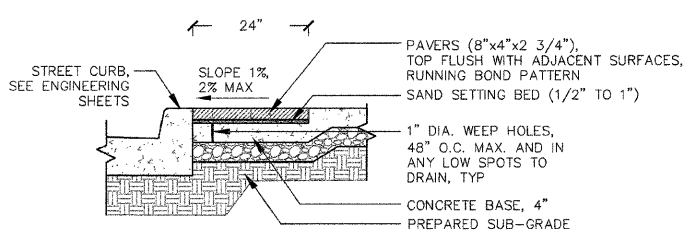

L
4-2 **BRICK PAVER BORDER ADJACENT TO CURB/SIDEWALK**
NOT TO SCALE

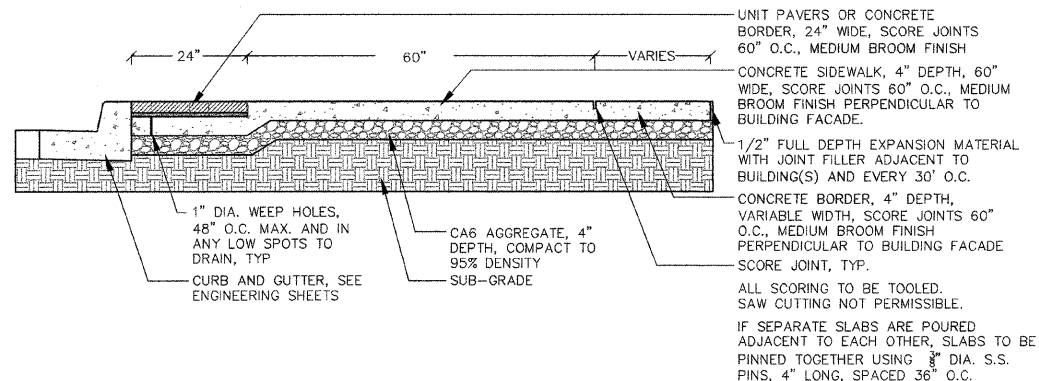
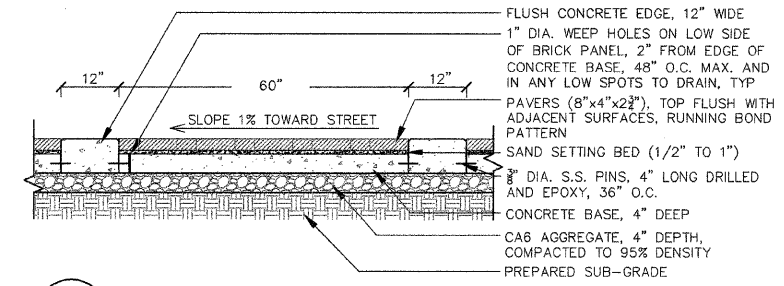

L
4-3 **BRICK PAVERS AND FLUSH CONCRETE CURBS**
NOT TO SCALE

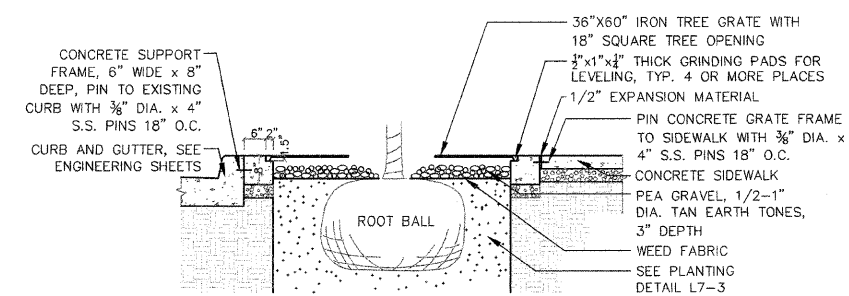

L
4-4 **TREE GRATE ADJACENT TO CURB AND SIDEWALK**
NOT TO SCALE

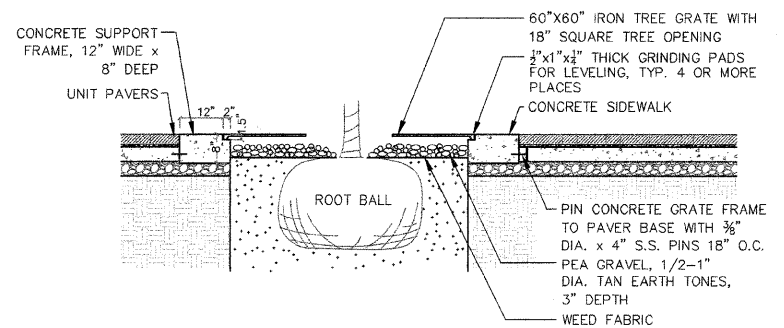

L
4-5 **TREE GRATE IN PLAZA AREA**
NOT TO SCALE

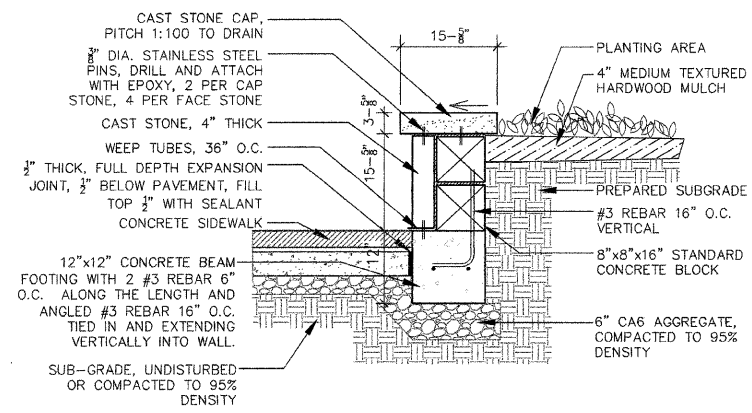

L
4-6 **STONE RETAINING WALL**
NOT TO SCALE

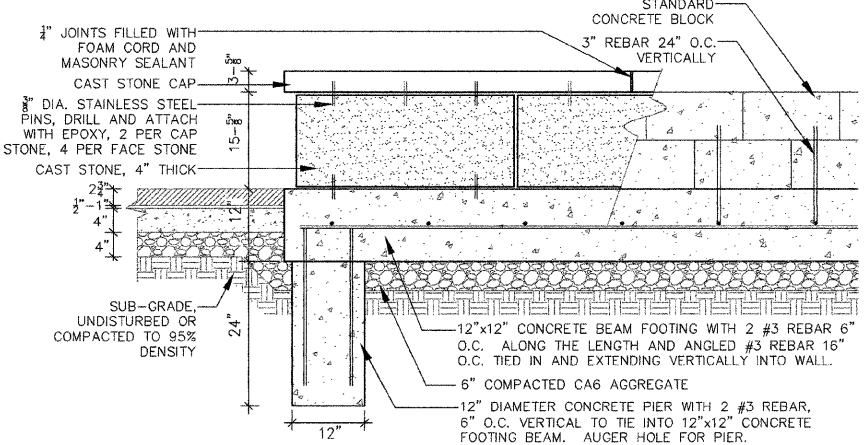

L
4-7 **STONE RETAINING WALL**
NOT TO SCALE

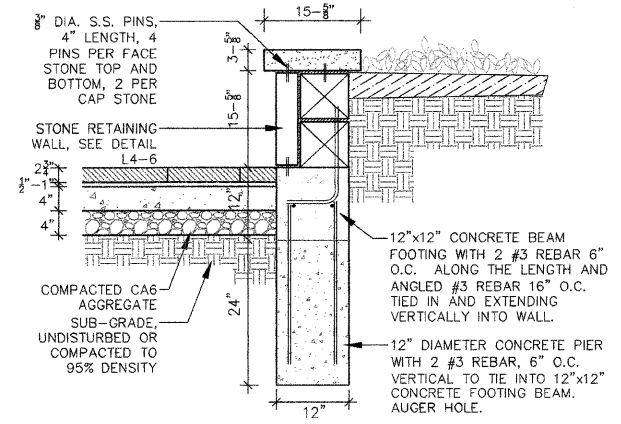

L
4-8 **STONE RETAINING WALL**
NOT TO SCALE

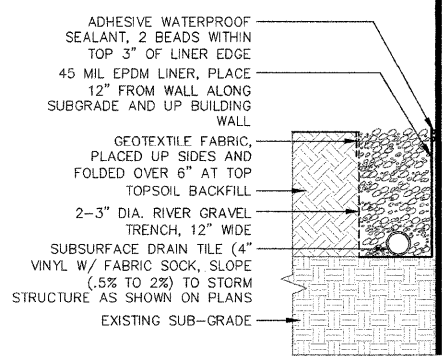

L
4-9 **WATERPROOF LINER AND DRAIN TILE**
NOT TO SCALE

FILE NAME = \$FILEL\$	USER NAME =	DESIGNED - SM	REVISED -	STATE OF ILLINOIS DEPARTMENT OF TRANSPORTATION	CITY OF JACKSONVILLE DOWNTOWN MAIN STREET IMPROVEMENTS PAVEMENT AND WALL DETAILS		F.A.R.T.E. = N/A	SECTION = 10-00121-01-PV	COUNTY = MORGAN	TOTAL SHEETS = 77	SHEET NO. = 51	
	PLOT SCALE =	DRAWN - NFB	REVISED -		SCALE:	SHEET NO. - OF - SHEETS	STA. _____ TO STA. _____	CONTRACT NO. 93547				
	PLOT DATE = 2-8-2011	CHECKED - SM	REVISED -					FED. ROAD DIST. NO. - ILLINOIS FED. AID PROJECT				
		DATE = 2-8-2011	REVISED -									