

ROUTE NO.	SECTION	COUNTY	TOTAL SHEETS	SHEET NO.
FAU 8390	04-00084-01-PV	EFFINGHAM	139	6
FED. ROAD DIST. NO. 7	ILLINOIS	CONTRACT #95639		

- PAVING LEGEND**
- ① HOT-MIX ASPHALT SURFACE COURSE, MIX "C", N70, 1 3/4"
 - ② HOT-MIX ASPHALT BINDER COURSE, IL-19.0, N70, 1 3/4"
 - ③ HOT-MIX ASPHALT BINDER COURSE, IL-19.0, N70, 1 3/4"
 - ④ 10" SOIL CEMENT BASE COURSE, CONSIST OF 5" AGGREGATE BASE COURSE, TYPE A AND 5" OF SOIL ALL MIXED WITH 12% CEMENT (BY VOLUME)
 - ⑤ HOT-MIX ASPHALT SURFACE COURSE, MIX "C", N70, 1 3/4"
 - ⑥ AGGREGATE BASE COURSE, TYPE A, 8"

Revised 5-31-2011

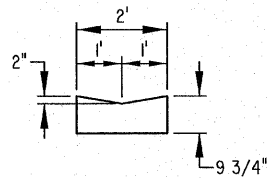

"V" TYPE GUTTER, SPECIAL

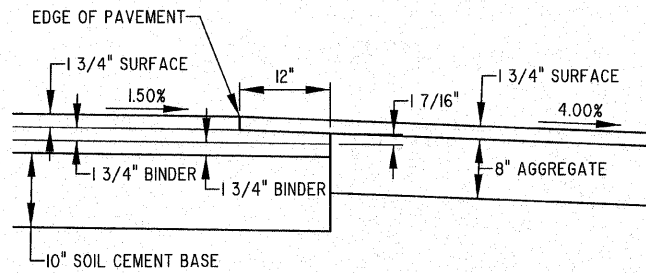

THICKNESS TRANSITION - HOT-MIX BINDER

PAVEMENT DESIGN - EVERGREEN AVENUE
SECTION 04-00084-01-PV
STA. 27+79.94 TO STA. 94+92.73
WINPAS PAVEMENT ANALYSIS SOFTWARE
CLASS II STREET: LOCAL ROAD (80,000 lb Trucks)

URBAN
STRUCTURAL DESIGN PV=2966
TRAFFIC (2021): SU=III
MU=7
TOTAL FLEXIBLE ESALS: 3,207,562
REQUIRED STRUCTURAL NUMBER: 5.47
DESIGNED STRUCTURAL NUMBER: 5.67

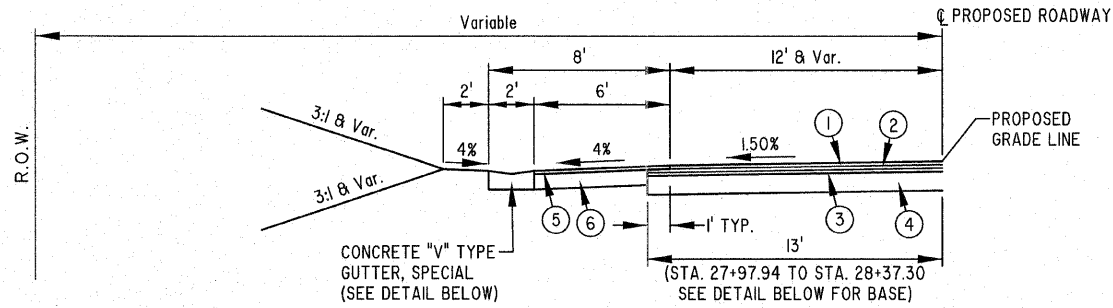

TYPICAL SECTION - EVERGREEN AVENUE
LT STA. 27+79.94 TO STA. 32+35.30

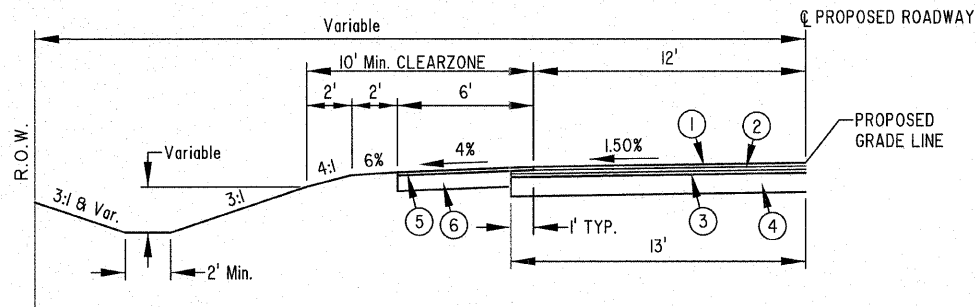

TYPICAL SECTION - EVERGREEN AVENUE
LT STA. 32+35.30 TO STA. 32+63.87

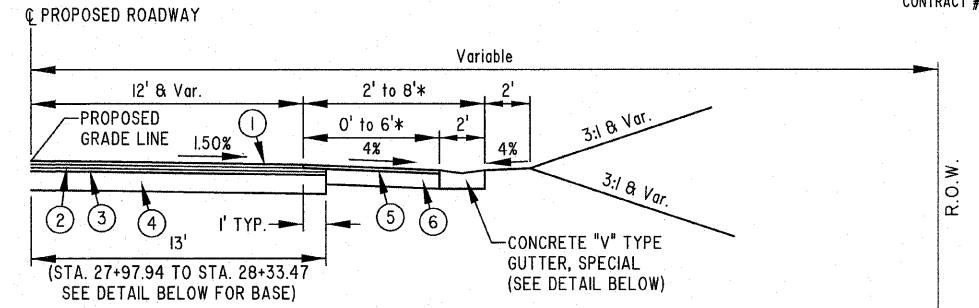

TYPICAL SECTION - EVERGREEN AVENUE
RT STA. 27+79.94 TO STA. 28+33.47

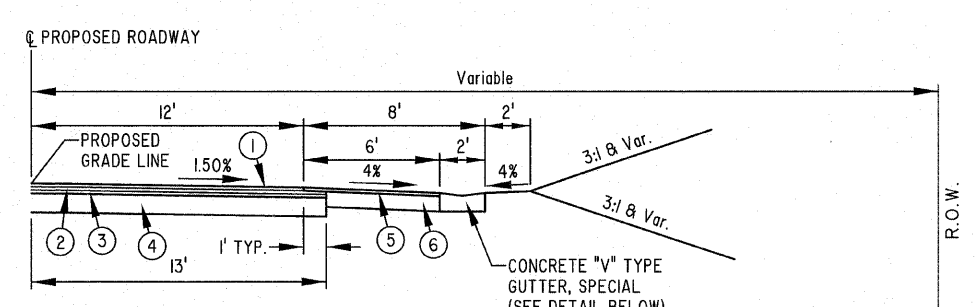

TYPICAL SECTION - EVERGREEN AVENUE
RT STA. 28+33.47 TO STA. 32+63.87

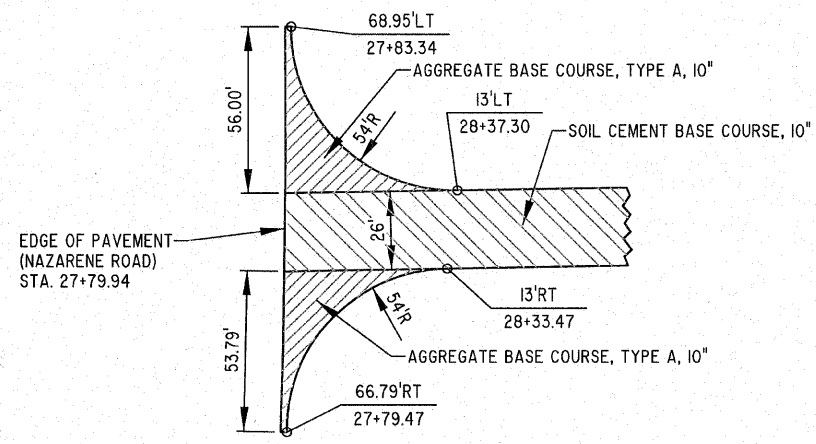

NAZARENE ROAD AND EVERGREEN AVENUE
INTERSECTION BASE DETAIL

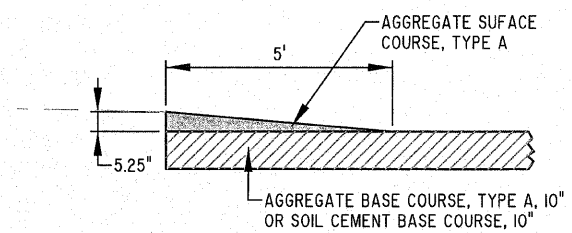

NAZARENE ROAD AND EVERGREEN AVENUE
TEMPORARY FILLET DETAIL

STA. 27+79.94 TO STA. 32+63.87

MILANO & GRUNLOH ENGINEERS, LLC
84 WEST WASHINGTON
P.O. BOX 697
EFFINGHAM, ILLINOIS 62401
PHONE: (217) 347-7252
(800) 677-2714
FAX #: (217) 342-3433

TYPICAL SECTIONS
EVERGREEN AVENUE
COUNTY OF EFFINGHAM, ILLINOIS

File name: S:\DWG\05\05227.dwg; Typical.dwg
Plot date: 02/08/11 at 16:00