

ELEVATION
Showing Rail Post Spacing
See sheet 5 of 8 for Railing Details.

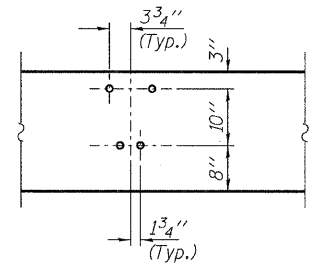

DETAIL A

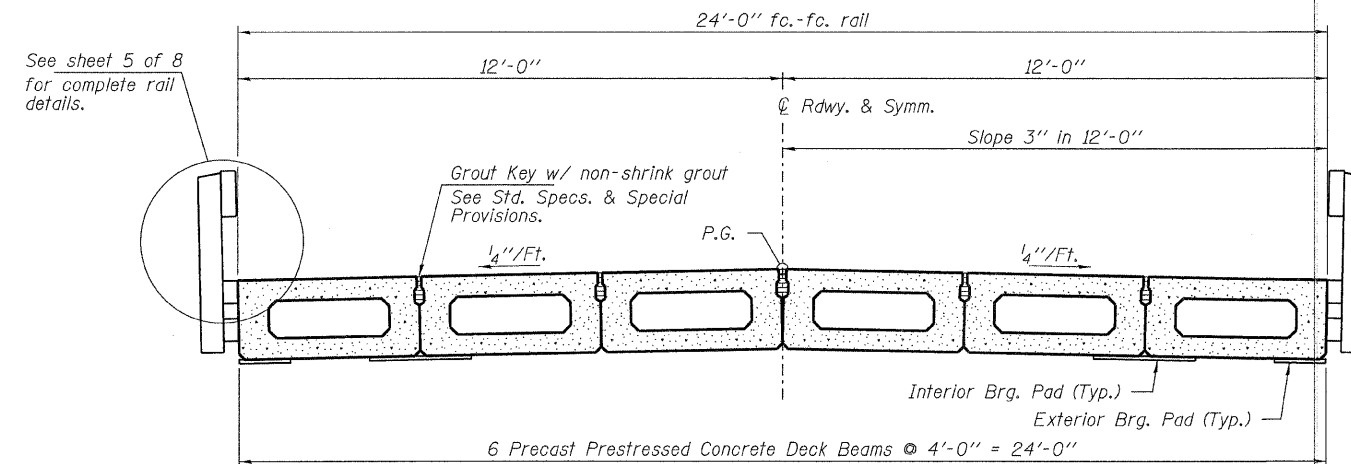

CROSS SECTION
See sheets 2 & 3 of 8 for Superstructure.

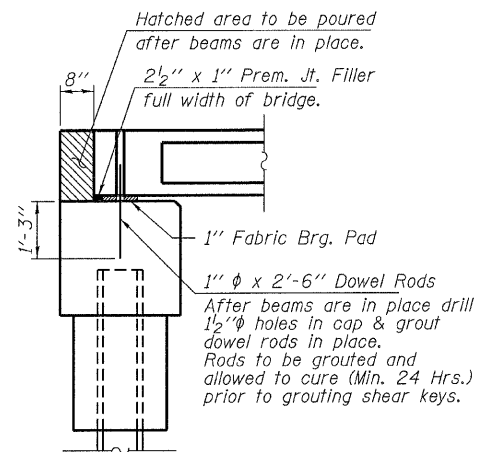

SECTION AT ABUTMENTS
© R.I. L's

FILE NAME = 180231-sht-brIDGE.dgn	USER NAME =	DESIGNED - A.S.L.	REVISED -	STATE OF ILLINOIS GALLATIN COUNTY HIGHWAY DEPARTMENT	SUPERSTRUCTURE DETAILS STRUCTURE NO. 030-3134	F.A.S.	SECTION	COUNTY	TOTAL SHEETS	SHEET NO.	
HAMPTON, LENZINI AND RENWICK, INC. 3085 STEVENSON DRIVE, SUITE 201 SPRINGFIELD, ILLINOIS 62708		CHECKED - S.W.M.	REVISED -			892	10-00075-00-BR	GALLATIN	25	21	
HLR ILLINOIS PROFESSIONAL DESIGN FIRM LS / PE / SE CORP 184-000989	PLOT SCALE =	DRAWN - D.T.M.	REVISED -			CONTRACT NO. 99456					
	PLOT DATE = 3/14/2011	CHECKED - S.W.M.	REVISED -			SHEET NO. 4 OF 8 SHEETS					
						ILLINOIS FED. AID PROJECT					