

STATE OF ILLINOIS  
DEPARTMENT OF TRANSPORTATION  
**PROPOSED  
HIGHWAY PLANS**

FOR INDEX OF SHEETS, SEE SHEETS NO. 3 & 4

IMPROVEMENTS LOCATED IN THE VILLAGE OF SHOREWOOD,  
CITY OF JOLIET, TROY TOWNSHIP, AND WILL COUNTY

**DESIGN DESIGNATION**

5430(30) OTHER PRINCIPAL ARTERIAL 43.85 (PCC-20)

**TRAFFIC DATA**

	EXISTING ADT 2016	DESIGN ADT 2040	DESIGN SPEED	POSTED SPEED																									
I-55	62,300	90,300	70	65																									
IL RTE 59 (DDI)	N/A	40,200	30	30																									
ROCK RUN CROSSINGS DR	4,100	7,100	30	25																									
RAMP A	N/A	4,500	50	N/A																									
RAMP B	N/A	4,500	50	N/A </tr <tr> <td>RAMP C</td> <td>11,600</td> <td>11,500</td> <td>50</td> <td>N/A</td> </tr> <tr> <td>RAMP D</td> <td>11,200</td> <td>11,500</td> <td>50</td> <td>N/A</td> </tr> <tr> <td>SEIL RD</td> <td>10,900</td> <td>23,000</td> <td>40</td> <td>35</td> </tr> <tr> <td>W FRONTAGE RD</td> <td>2,200</td> <td>9,800</td> <td>40</td> <td>35</td> </tr> <tr> <td>E FRONTAGE RD</td> <td>4,100</td> <td>7,100</td> <td>45</td> <td>45</td> </tr>	RAMP C	11,600	11,500	50	N/A	RAMP D	11,200	11,500	50	N/A	SEIL RD	10,900	23,000	40	35	W FRONTAGE RD	2,200	9,800	40	35	E FRONTAGE RD	4,100	7,100	45	45
RAMP C	11,600	11,500	50	N/A																									
RAMP D	11,200	11,500	50	N/A																									
SEIL RD	10,900	23,000	40	35																									
W FRONTAGE RD	2,200	9,800	40	35																									
E FRONTAGE RD	4,100	7,100	45	45																									

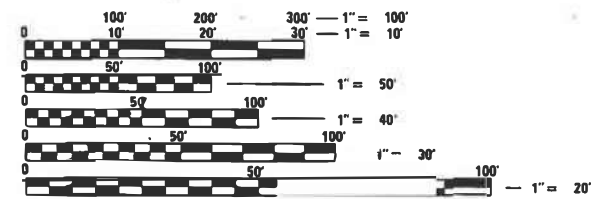

FULL SIZE PLANS HAVE BEEN PREPARED USING STANDARD ENGINEERING SCALES. REDUCED SIZED PLANS WILL NOT CONFORM TO STANDARD SCALES. IN MAKING MEASUREMENTS ON REDUCED PLANS, THE ABOVE SCALES MAY BE USED.

J.U.L.I.E.  
JOINT UTILITY LOCATION INFORMATION FOR EXCAVATION  
1-800-892-0123  
OR 811

MEADE ELECTRIC CO. DISTRICT ONE ELECTRICAL  
MAINTENANCE COORDINATOR LOCATES IDOT ELECTRICAL  
EQUIPMENT AND UNDERGROUND CABLES  
773-287-7672

PROJECT ENGINEER - CRAIG BAUER 847-705-4265  
PROJECT MANAGER - LONG TRAN 847-705-4232

CONTRACT NO. 62H15

**F.A.I. ROUTE 55 (I-55)  
SECTION 2018-075-R  
PROJECT BTDG-69NC(103)  
INTERCHANGE RECONSTRUCTION & ADD AUXILIARY LANES  
WILL COUNTY  
C-91-208-19**

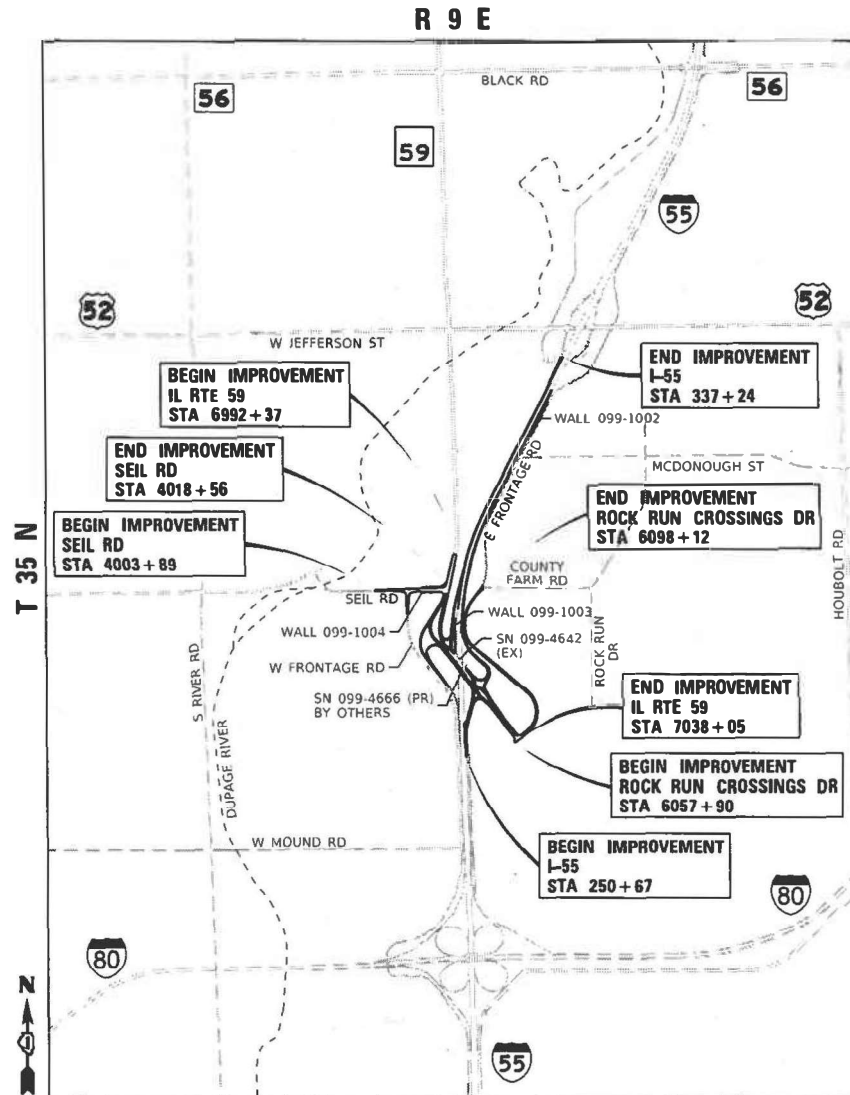

**TROY TOWNSHIP**  
GROSS LENGTH I-55=8,657 FT.=1.64 MILE    GROSS LENGTH ROCK RUN CROSSINGS DR=4,020 FT.=0.76 MILE  
GROSS LENGTH IL RTE 59=4,568 FT.=0.87 MILE    GROSS LENGTH W FRONTAGE RD=428 FT.=0.08 MILE  
GROSS LENGTH SEIL RD=1,467 FT.=0.28 MILE

F.A.I. UP RTE.	SECTION	COUNTY	TOTAL SHEETS	SHEET NO.
	2018-075-R	WILL	1510	1
* FAI 55, FAP 338		ILLINOIS	CONTRACT NO. 62H15	

**D-91-368-18**

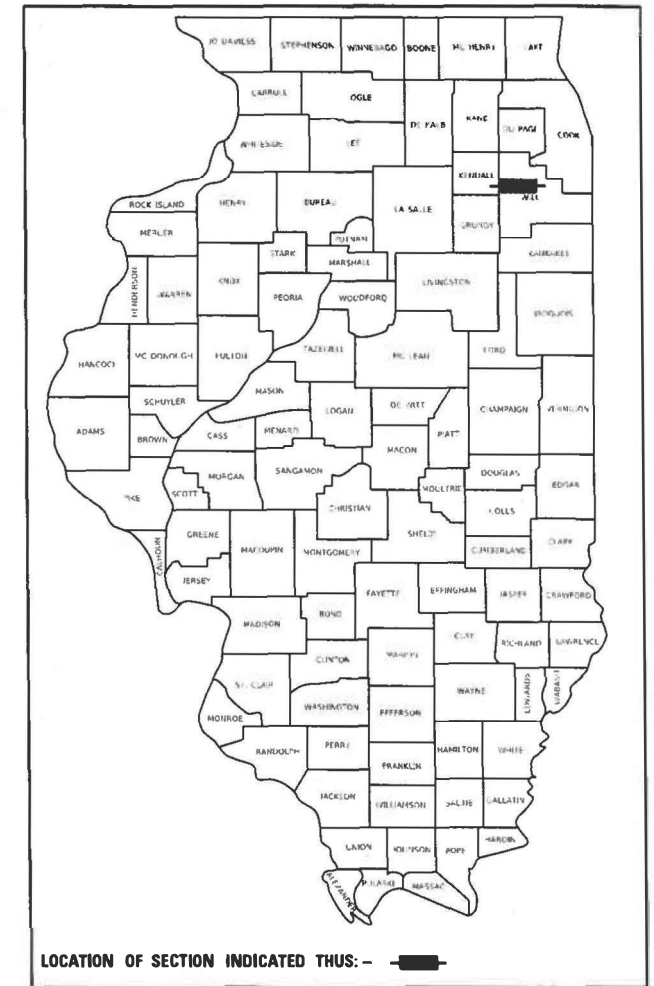

LOCATION OF SECTION INDICATED THUS: - [shaded rectangle] -

STATE OF ILLINOIS  
DEPARTMENT OF TRANSPORTATION

SUBMITTED March 9 20 22  
Jon Eric Long  
REGIONAL ENGINEER

May 13, 2022 [Signature]  
ENGINEER OF DESIGN AND ENVIRONMENT

May 13, 2022 [Signature]  
DIRECTOR OF HIGHWAYS PROJECT IMPLEMENTATION

**PRINTED BY THE AUTHORITY  
OF THE STATE OF ILLINOIS**

BENESCH  
PATRICK J. O'BRIEN  
062-049239



DATE: 02-04-2022



SHEETS: ALL SHEETS EXCEPT NOTED BELOW AND TO THE RIGHT

EXPIRATION DATE: 11-30-2023

SINGH  
RACIEL OCAMPO  
062-070793



DATE: 02-04-2022

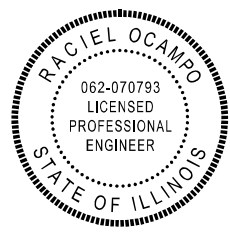

SHEETS: MAINTENANCE OF TRAFFIC

EXPIRATION DATE: 11-30-2023

ACCURATE  
DAVID A HEYDEN  
062.051707



DATE: 02-04-2022



SHEETS: PAVEMENT MARKING AND SIGNING

EXPIRATION DATE: 02-28-2022

BENESCH  
KURT J. NAUS  
081-006578



DATE: 02-04-2022

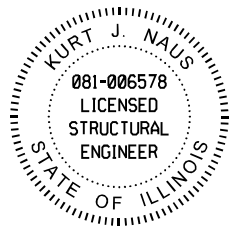

SHEETS:  
CONCRETE BARRIER WALL (SPECIAL) AT SN 099-4666,  
CONCRETE BARRIER TRANSITIONS AT I-55 MEDIAN  
SIGN STRUCTURE FOUNDATIONS, SEIL ROAD CULVERT  
EXTENSION, AND RETAINING WALL - SN 099-1004

EXPIRATION DATE: 11-30-2022

SINGH  
RASHESHKUMAR D. PATEL  
062-064617

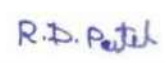

DATE: 02-04-2022



SHEETS: ROADWAY LIGHTING

EXPIRATION DATE: 11-30-2023

ARDMORE RODERICK  
FRANCIS J. POWERS  
081-004739



DATE: 02-04-2022

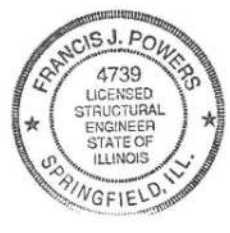

SHEETS: CONCRETE BARRIER, SINGLE FACE, 44 INCH HEIGHT AND RETAINING WALLS - SN 099-1002 & SN 099-1003

EXPIRATION DATE: 11-30-2022

THOMAS  
BRIAN L. PAWULA  
062-061268



DATE: 02-04-2022



SHEETS: REMOVALS, DRAINAGE, EROSION CONTROL,  
AND LANDSCAPING

EXPIRATION DATE: 11-30-2023

SINGH  
EDDIE E. CHOI  
062-069424



DATE: 02-04-2022



SHEETS: TRAFFIC SIGNALS

EXPIRATION DATE: 11-30-2023

BENESCH  
TIMOTHY P. SCHMIDT  
081-007314



DATE: 02-04-2022



SHEETS: BRIDGE PLANS - SN 099-4666, APPROACH MODIFICATION DETAILS  
& EXISTING PLANS - SN 099-4642, AND IL RTE 59 CULVERT EXTENSION

EXPIRATION DATE: 11-30-2022

BENESCH  
JOHN H. GISLASON  
081-006703



DATE: 02-04-2022

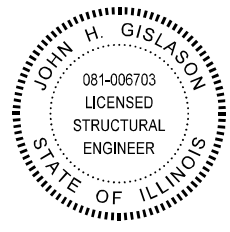

SHEETS: KINDER MORGAN GAS LINES - PROTECTION SLABS AND OVERHEAD SIGN STRUCTURES

EXPIRATION DATE: 11-30-2022

MODEL: Default  
FILE: SealSeals-01.dgn  
C:\Users\jw\Documents\107005\107040\_000\Eng\_Docs\_Phase II\General\107005\107040\_000\Seals-01.dgn



USER NAME = jwthington	DESIGNED - TKLUEGEL	REVISED -
PLOT SCALE = 240,0000' / ft.	DRAWN - JWORTHINGTON	REVISED -
PLOT DATE = 2/9/2022	CHECKED - POBRIEN	REVISED -
	DATE - 03/16/2022	REVISED -

STATE OF ILLINOIS  
DEPARTMENT OF TRANSPORTATION

SEALS AND SIGNATURES

SCALE: NONE SHEET OF SHEETS STA. TO STA.

F.A./P RTE.	SECTION	COUNTY	TOTAL SHEETS	SHEET NO.
*	2018-075-R	WILL	1510	2
CONTRACT NO. 62H15				
* FAI 55, FAP 338 ILLINOIS FED. AID PROJECT				

**INDEX OF SHEETS**

SHEET	DESCRIPTION
1	COVER SHEET
2	SEALS AND SIGNATURES
3 - 4	INDEX OF SHEETS
5	HIGHWAY STANDARDS
6	GENERAL NOTES AND COMMITMENTS
7 - 8	OVERALL PLAN REFERENCE
9 - 44	SUMMARY OF QUANTITIES
45 -49	EXISTING TYPICAL SECTIONS
50	HMA MIXTURE REQUIREMENTS
51 - 64	PROPOSED TYPICAL SECTIONS
65 - 92	SCHEDULE OF QUANTITIES
93 - 101	ALIGNMENT, BENCHMARKS, AND TIES
102	KINDER MORGAN GAS LINES - CONSTRUCTION NOTES
103 - 113	KINDER MORGAN GAS LINES - PLAN & PROFILES
114 - 120	KINDER MORGAN GAS LINES - PROTECTION SLABS
121	KINDER MORGAN GAS LINES - CONTROLLED LOW STRENGTH MATERIAL
122	KINDER MORGAN PIPELINE CROSSINGS - TEMPORARY BRIDGE (AIR BRIDGE)
123 - 124	CONTRACTOR ACCESS EXCLUSION ZONES
125 - 128	ACCESS CONTROL FENCE
129 - 141	GRADING PLANS
142 - 154	ASSUMED EXISTING TOPSOIL THICKNESS PLAN
155 - 168	PROPOSED TOPSOIL THICKNESS PLAN
169	TOPSOIL STOCKPILES PLAN
170 - 180	UNDERCUT PLANS
181	MAINTENANCE OF TRAFFIC GENERAL NOTES
182	MAINTENANCE OF TRAFFIC SEQUENCE OF CONSTRUCTION
183	MAINTENANCE OF TRAFFIC SIGN LEGEND
184 - 189	MAINTENANCE OF TRAFFIC TYPICAL SECTIONS
190 - 192	MAINTENANCE OF TRAFFIC - PRE-STAGE 1
193 - 203	MAINTENANCE OF TRAFFIC - STAGE 1
204 - 211	MAINTENANCE OF TRAFFIC - STAGE 1A
212 - 235	MAINTENANCE OF TRAFFIC - STAGE 2
236 - 248	MAINTENANCE OF TRAFFIC - STAGE 2A
249 - 259	MAINTENANCE OF TRAFFIC - STAGE 3
260 - 275	MAINTENANCE OF TRAFFIC - STAGE 4

**INDEX OF SHEETS CONTINUED**

SHEET	DESCRIPTION
276 - 308	REMOVAL PLANS
309 - 337	ROADWAY PLAN AND PROFILES
338 - 340	E FRONTAGE RD IMPROVEMENTS AT NOISE WALL #2
341 - 354	GEOMETRIC LAYOUT
355 - 377	JOINTING PLANS
378 - 386	ADA RAMP DETAILS
387 - 390	RAISED INFIELD GRADING PLANS
391 - 395	CONCRETE BARRIER WALL (SPECIAL)
396 - 398	CONCRETE BARRIER, SINGLE FACE, 44 INCH HEIGHT
399 - 405	I-55 MEDIAN IMPROVEMENTS AT SIGN STRUCTURE FOUNDATIONS
406	CONCRETE BARRIER TRANSITIONS AT I-55 MEDIAN SIGN STRUCTURE FOUNDATIONS
407 - 420	NOISE WALL PLANS
421 - 457	EXISTING DRAINAGE PLANS
458 - 496	PROPOSED DRAINAGE PLANS
497 - 517	PIPE UNDERDRAIN PLANS
518 - 521	DETENTION POND DETAILS
522 - 528	DRAINAGE DETAILS
529	FIRE HYDRANT RELOCATION PLAN
530 - 540	SEIL ROAD DOUBLE BOX CULVERT EXTENSION
541 - 553	IL RTE 59 DOUBLE BOX CULVERT EXTENSION
554	EROSION AND SEDIMENT CONTROL - GENERAL NOTES
555 - 557	EROSION AND SEDIMENT CONTROL - SCHEDULE OF QUANTITIES
558 - 579	EROSION AND SEDIMENT CONTROL PLANS - STAGE 1
580 - 601	EROSION AND SEDIMENT CONTROL PLANS - STAGE 1A
602 - 623	EROSION AND SEDIMENT CONTROL PLANS - STAGE 2
624 - 645	EROSION AND SEDIMENT CONTROL PLANS - STAGE 2A
646 - 667	EROSION AND SEDIMENT CONTROL PLANS - STAGE 3
668 - 673	EROSION AND SEDIMENT CONTROL DETAILS
674 - 750	SUE INVESTIGATION OF UNDERGROUND UTILITIES
751 - 762	PLAT OF HIGHWAYS
763 - 813	PAVEMENT MARKING AND SIGNING PLANS
814 - 837	SIGN PANEL DETAILS
838 - 872	OVERHEAD SIGN STRUCTURE PLANS
873 - 910	TRAFFIC SIGNAL PLANS

MODEL: Default  
 FILE: M:\MFC\_Plan\benesch-plan\benesch-plan\107005\10740\_001\Eng\_Docs\_Phase\_1\General\162H15-shi-index-01.dgn



USER NAME = jworthington	DESIGNED - NREYNOLDS	REVISED -
	DRAWN - JWORTHINGTON	REVISED -
PLOT SCALE = 240,0000 ' / ft.	CHECKED - POBRIEN	REVISED -
PLOT DATE = 2/2/2022	DATE - 02/04/2022	REVISED -

**STATE OF ILLINOIS  
 DEPARTMENT OF TRANSPORTATION**

**INDEX OF SHEETS**

SCALE: NONE SHEET OF SHEETS STA. TO STA.

F.A./P RTE.	SECTION	COUNTY	TOTAL SHEETS	SHEET NO.
*	2018-075-R	WILL	1510	3
CONTRACT NO. 62H15				
* FAI 55, FAP 338 ILLINOIS FED. AID PROJECT				

**INDEX OF SHEETS CONTINUED**

SHEET	DESCRIPTION
911 - 925	LANDSCAPE PLANS
926 - 964	ROADWAY LIGHTING PLANS
965 - 996	TRAFFIC SURVEILLANCE PLANS
997 - 1022	BRIDGE PLANS - NB IL RTE 59 OVER I-55 - SN 099-4666
1023 - 1033	APPROACH MODIFICATION DETAILS & EXISTING PLANS
1034 - 1049	RETAINING WALL SN 099-1002
1050 - 1057	RETAINING WALL SN 099-1003
1058 - 1070	RETAINING WALL SN 099-1004
1071	DRIVEWAY DETAILS - DISTANCE BETWEEN R.O.W. AND FACE OF CURB & EDGE OF SHOULDER $\geq 15'$ (4.5m) (BD-01)
1072	DRIVEWAY DETAILS - DISTANCE BETWEEN ROW AND FACE OF CURB < 15'(4.5m) (BD-02)
1073	MANHOLE WITH RESTRICTOR PLATE (BD-12)
1074	BUTT JOINT AND HMA TAPER DETAILS (BD-32)
1075	DETAILS FOR DEPRESSED CURB & GUTTER AND SHOULDER TREATMENT AT TBT TY, 1 SPL. (BD-34)
1076	BENCHING DETAIL FOR EMBANKMENT WIDENING (BD-51)
1077	DETAIL OF PAVEMENT SEPARATION JOINT FOR JOINTED PCC PAVEMENTS AT INTERSECTIONS (BD-52)
1078 - 1079	LIGHTING CONTROLLER, BASE MOUNTED, 480VOLT, 200AMP (DUAL) RADIO SCADA (BE-205)
1080	ELECTRIC SERVICE INSTALLATION AERIAL, REMOTE DISCONNECT (BE-220)
1081	LIGHT POLE FOUNDATION 40' (12.192 m) TO 47 1/2" (14.478 m) M.H. 15" (381 mm) BOLT CIRCLE (BE-301)
1082	DAVIT LIGHT POLE 47'-6" (14.478 m) MOUNTING HEIGHT (BE-410)
1083	LUMINAIRE SAFETY CABLE ASSEMBLY (BE-701)
1084	MISC. ELECTRICAL DETAILS SHEET A (BE-702)
1085	COMMUNICATIONS VAULT, COMPOSITE CONCRETE (BE-705)
1086	TEMPORARY LIGHT POLE DETAILS (BE-800)
1087	TEMPORARY AERIAL CABLE INSTALLATION (BE-801)
1088	SUSPENDED MOUNT LED UNDERPASS LUMINAIRE INSTALLATION DETAILS (BE-901)
1089	FIBER ASSIGNMENTS 96 FIBER TRUNK CABLE (BE-2100)
1090	FIBER ASSIGNMENTS 96 FIBER DISTRIBUTION CABLE (BE-2110)
1091	FIBER ASSIGNMENTS 12 FIBER LATERAL CABLE (BE-2130)
1092	ENTRANCE AND EXIT RAMP CLOSURE DETAILS (TC-08)
1093	TRAFFIC CONTROL DETAILS FOR FREEWAY SINGLE & MULTI-LANE WEAVE (TC-09)
1094	TRAFFIC CONTROL AND PROTECTION FOR SIDE ROADS, INTERSECTIONS, AND DRIVEWAYS (TC-10)
1095	TYPICAL APPLICATIONS RAISED REFLECTIVE PAVEMENT MARKERS (SNOW-PLOW RESISTANT) (TC-11)
1096 - 1097	MULTI-LANE FREEWAY PAVEMENT MARKING DETAILS (TC-12)

**INDEX OF SHEETS CONTINUED**

SHEET	DESCRIPTION
1098	DISTRICT ONE TYPICAL PAVEMENT MARKINGS (TC-13)
1099	TRAFFIC CONTROL AND PROTECTION AT TURN BAYS (TO REMAIN OPEN TO TRAFFIC) (TC-14)
1100	SHORT TERM PAVEMENT MARKING LETTERS AND SYMBOLS (TC-16)
1101	TRAFFIC CONTROL DETAILS FOR FREEWAY SHOULDER CLOSURES AND PARTIAL RAMP CLOSURES (TC-17)
1102	FREEWAY/EXPRESSWAY SIGNING FOR FLAGGING OPERATIONS AT WORK ZONE OPENINGS ON FREEWAYS/EXPRESSWAYS (TC-18)
1103	ARTERIAL ROAD INFORMATION SIGN (TC-22)
1104	DRIVEWAY ENTRANCE SIGNING (TC-26)
1105	MILE POST MARKERS - GORE SIGNS MAJOR GUIDE SIGN LAYOUT - ARROWS (TC-27)
1106	OVERHEAD SIGN STRUCTURE SUPPORT DETAIL FOR SIGN PANELS EXCEEDING HEIGHT IF EXISTING TRUSS (TC-32)
1107 - 1210	CROSS SECTIONS - I-55
1211 - 1287	CROSS SECTIONS - IL RTE 59 SB
1288 - 1329	CROSS SECTIONS - IL RTE 59 NB
1330 - 1353	CROSS SECTIONS - RAMP A
1354 - 1379	CROSS SECTIONS - RAMP B NB
1380 - 1388	CROSS SECTIONS - RAMP B SB
1389 - 1405	CROSS SECTIONS - RAMP C
1406 - 1416	CROSS SECTIONS - RAMP D NB
1417 - 1438	CROSS SECTIONS - RAMP D SB
1439 - 1456	CROSS SECTIONS - SEIL RD
1457 - 1461	CROSS SECTIONS - W FRONTAGE RD
1462 - 1500	CROSS SECTIONS - ROCK RUN CROSSINGS DR
1501 - 1510	CROSS SECTIONS - US 52 RAMP D

MODEL: Default  
 FILE: \na\15\15-shi-index-02.dgn  
 USER: jworthington  
 PROJECT: 2018-075-R  
 SHEET: 4  
 CONTRACT NO. 62H15



USER NAME = jworthington	DESIGNED - NREYNOLDS	REVISED -
PLOT SCALE = 240,0000 ' / ft.	CHECKED - POBRIEN	REVISED -
PLOT DATE = 2/2/2022	DATE - 02/04/2022	REVISED -

**STATE OF ILLINOIS  
DEPARTMENT OF TRANSPORTATION**

**INDEX OF SHEETS**

SCALE: NONE SHEET OF SHEETS STA. TO STA.

F.A./P RTE.	SECTION	COUNTY	TOTAL SHEETS	SHEET NO.
*	2018-075-R	WILL	1510	4
CONTRACT NO. 62H15				
* FAI 55, FAP 338 ILLINOIS FED. AID PROJECT				

**IDOT HIGHWAY STANDARDS**

STANDARD NO	TITLE
000001-08	STANDARD SYMBOLS, ABBREVIATIONS AND PATTERNS
001001-02	AREAS OF REINFORCEMENT BARS
001006	DECIMAL OF AN INCH AND OF A FOOT
280001-07	TEMPORARY EROSION CONTROL SYSTEMS
420001-10	PAVEMENT JOINTS
420106-07	36' (10.8 M) JOINTED PCC PAVEMENT
420111-04	PCC PAVEMENT ROUNDOUTS
420401-13	PAVEMENT CONNECTOR (PCC) FOR BRIDGE APPROACH SLAB
424001-11	PERPENDICULAR CURB RAMPS FOR SIDEWALKS
424006-05	DIAGONAL CURB RAMPS FOR SIDEWALKS
424011-04	CORNER PARALLEL CURB RAMPS FOR SIDEWALKS
424016-05	MID-BLOCK CURB RAMPS FOR SIDEWALKS
424021-06	DEPRESSED CORNER FOR SIDEWALKS
424026-03	ENTRANCE / ALLEY PEDESTRIAN CROSSINGS
424031-02	MEDIAN PEDESTRIAN CROSSINGS
483001-06	PCC SHOULDER
515001-04	NAME PLATE FOR BRIDGES
542001-06	CONCRETE END SECTIONS FOR PIPE CULVERTS 15" (375 MM) THRU 84" (2100 MM) DIA.
542011-02	CONCRETE END SECTIONS FOR ELLIPTICAL PIPE CULVERTS 15" (375 MM) THRU 72" (1800 MM) EQUIVALENT DIAME
542301-03	PRECAST REINFORCED CONCRETE FLARED END SECTION
542306-03	PRECAST REINFORCED CONCRETE ELLIPTICAL FLARED END SECTION
542311-07	TRAVERSABLE PIPE GRATE FOR CONCRETE END SECTION
542546-01	FLUSH INLET BOX FOR MEDIAN
542601-03	REINFORCED CONCRETE PIPE ELBOW 24", 30" OR 36" (600 MM, 750 MM OR 900 MM)
601001-05	PIPE UNDERDRAINS
601101-02	CONCRETE HEADWALL FOR PIPE UNDERDRAINS
602001-02	CATCH BASIN, TYPE A
602006-04	CATCH BASIN, TYPE B
602301-04	INLET, TYPE A
602306-03	INLET, TYPE B
602401-07	PRECAST MANHOLE TYPE A 4' (1.22 M) DIAMETER
602402-03	PRECAST MANHOLE TYPE A 5' (1.52 M) DIAMETER
602406-11	PRECAST MANHOLE TYPE A 6' (1.83 M) DIAMETER
602411-09	PRECAST MANHOLE TYPE A 7' (2.13 M) DIAMETER
602416-09	PRECAST MANHOLE TYPE A 8' (2.44 M) DIAMETER
602421-09	PRECAST MANHOLE TYPE A 9' (2.74 M) DIAMETER
602601-06	PRECAST REINFORCED CONCRETE FLAT SLAB TOP
602701-02	MANHOLE STEPS
604001-05	FRAME AND LIDS, TYPE 1
604031-03	GRATE, TYPE 7
604036-03	GRATE, TYPE 8
604051-04	FRAME AND GRATE, TYPE 11
604056-04	FRAME AND GRATE, TYPE 11V
604071-07	FRAME AND GRATE, TYPE 20
604091-05	FRAME AND GRATE, TYPE 24
606001-08	CONCRETE CURB TYPE B AND COMBINATION CONCRETE CURB AND GUTTER
606006-04	OUTLET FOR CONCRETE CURB AND GUTTER, TYPE B-6.24 (B-15.60)
606201-04	TYPE B GUTTER (INLET, OUTLET, & ENTRANCE)
606301-04	PC CONCRETE ISLANDS AND MEDIANS
606401-02	PAVED DITCH
630001-12	STEEL PLATE BEAM GUARDRAIL
630201-07	PCC/HMA STABILIZATION AT STEEL PLATE BEAM GUARDRAIL
630301-09	SHOULDER WIDENING FOR TYPE 1 (SPECIAL) GUARDRAIL TERMINALS

**IDOT HIGHWAY STANDARDS**

STANDARD NO	TITLE
631011-10	TRAFFIC BARRIER TERMINAL, TYPE 2
631031-17	TRAFFIC BARRIER TERMINAL, TYPE 6
631046-04	TRAFFIC BARRIER TERMINAL, TYPE 10
635001-02	DELINEATORS
642001-03	SHOULDER RUMBLE STRIPS, 16 IN.
643001-02	SAND MODULE IMPACT ATTENUATORS
664001-02	CHAIN LINK FENCE
701001-02	OFF-RD OPERATIONS, 2L, 2W, MORE THAN 15' (4.5 M) AWAY
701006-05	OFF-RD OPERATIONS, 2L, 2W, 15' (4.5 M) TO 24" (600 MM) FROM PAVEMENT EDGE
701101-05	OFF-ROAD OPERATIONS, MULTILANE, 15' (4.5 M) TO 24" (600 MM) FROM PAVEMENT EDGE
701301-04	LANE CLOSURE, 2L, 2W, SHORT TIME OPERATIONS
701311-03	LANE CLOSURE, 2L, 2W, MOVING OPERATIONS - DAY ONLY
701326-04	LANE CLOSURE, 2L, 2W, PAVEMENT WIDENING, FOR SPEEDS ≥ 45 MPH
701400-11	APPROACH TO LANE CLOSURE, FREEWAY/EXPRESSWAY
701401-13	LANE CLOSURE, FREEWAY/EXPRESSWAY
701411-09	LANE CLOSURE, MULTILANE, AT ENTRANCE OR EXIT RAMP, FOR SPEEDS ≥ 45 MPH
701426-09	LANE CLOSURE, MULTILANE, INTERMITTENT OR MOVING OPERATION, FOR SPEEDS ≥ 45 MPH
701427-05	LANE CLOSURE, MULTILANE, INTERMITTENT OR MOVING OPERATION, FOR SPEEDS ≤ 40 MPH
701428-01	TRAFFIC CONTROL SETUP AND REMOVAL FREEWAY/EXPRESSWAY
701501-06	URBAN LANE CLOSURE, 2L, 2W, UNDIVIDED
701502-09	URBAN LANE CLOSURE, 2L, 2W, WITH BIDIRECTIONAL LEFT TURN LANE
701601-09	URBAN LANE CLOSURE, MULTILANE, 1W OR 2W WITH NONTRAVERSABLE MEDIAN
701701-10	URBAN LANE CLOSURE, MULTILANE INTERSECTION
701801-06	SIDEWALK, CORNER OR CROSSWALK CLOSURE
701901-08	TRAFFIC CONTROL DEVICES
704001-08	TEMPORARY CONCRETE BARRIER
720001-01	SIGN PANEL MOUNTING DETAILS
720006-04	SIGN PANEL ERECTION DETAILS
720011-01	METAL POSTS FOR SIGNS, MARKERS & DELINEATORS
720021-03	SIGN PANELS EXTRUDED ALUMINUM TYPE
728001-01	TELESCOPING STEEL SIGN SUPPORT
729001-01	APPLICATIONS OF TYPES A & B METAL POSTS (FOR SIGNS & MARKERS)
731001-01	BASE FOR TELESCOPING STEEL SIGN SUPPORT
780001-05	TYPICAL PAVEMENT MARKINGS
781001-04	TYPICAL APPLICATIONS RAISED REFLECTIVE PAVEMENT MARKERS
782001-01	CURB REFLECTORS
805001-01	ELECTRICAL SERVICE INSTALLATION DETAILS
812001-01	RACEWAYS EMBEDDED IN STRUCTURE
814001-03	HANDHOLES
814006-03	DOUBLE HANDHOLES
821101-02	LUMINAIRE WIRING IN POLE
836001-04	LIGHT POLE FOUNDATION
857001-01	STANDARD PHASE DESIGNATION DIAGRAMS AND PHASE SEQUENCES
862001-01	UNINTERRUPTABLE POWER SUPPLY (UPS)
873001-02	TRAFFIC SIGNAL GROUNDING & BONDING
877001-08	STEEL MAST ARM ASSEMBLY AND POLE 16' THROUGH 55'
877011-10	STEEL COMB. MAST ARM ASSEMBLY AND POLE 16' THROUGH 55'
878001-11	CONCRETE FOUNDATION DETAILS
880001-01	SPAN WIRE MOUNTED SIGNALS AND FLASHING BEACON INSTALLATION
880006-01	TRAFFIC SIGNAL MOUNTING DETAILS
886001-01	DETECTOR LOOP INSTALLATIONS
886006-01	TYPICAL LAYOUTS FOR DETECTION LOOPS

MODEL: Default  
 FILE: M:\MFC\_Plan\benesch-plan\benesch-plan\107005\107040\_001\Eng\_Docs\_Phase II\General\162\115-sh-gemmate-01.dgn  
 D:\162\115-sh-gemmate-01.dgn  
 50 107  
 2012/11/30



USER NAME = jworthington	DESIGNED - NREYNOLDS	REVISED -
PLOT SCALE = 240,0000 ' / ft.	CHECKED - POBRIEN	REVISED -
PLOT DATE = 2/1/2022	DATE - 02/04/2022	REVISED -

**STATE OF ILLINOIS**  
**DEPARTMENT OF TRANSPORTATION**

<b>HIGHWAY STANDARDS</b>	
SCALE: NONE	SHEET OF SHEETS STA. TO STA.

F.A./P RTE.	SECTION	COUNTY	TOTAL SHEETS	SHEET NO.
*	2018-075-R	WILL	1510	5
CONTRACT NO. 62H15				
* FAI 55, FAP 338 ILLINOIS FED. AID PROJECT				

## GENERAL NOTES

- BEFORE STARTING ANY EXCAVATION, THE CONTRACTOR SHALL CALL "J.U.L.I.E." AT (800) 892-0123 OR 811 FOR FIELD LOCATIONS, BURIED ELECTRIC LINES, TELEPHONE AND GAS FACILITIES. (48 HOUR NOTIFICATION IS REQUIRED).
- THE CONTRACTOR SHALL COORDINATE CONSTRUCTION ACTIVITIES WITH UTILITY COMPANIES, THE VILLAGE OF SHOREWOOD, THE CITY OF JOLIET, AND TROY TOWNSHIP TO HAVE THE LOCATION OF EXISTING UTILITIES STAKED AT LEAST FORTY-EIGHT (48) HOURS PRIOR TO EXCAVATION.
- THE CONTRACTOR WILL NOT BE ALLOWED TO SET UP A YARD OR FIELD OFFICE ON STATE PROPERTY OR WITHIN WILL COUNTY PROPERTY WITHOUT WRITTEN PERMISSION FROM THE DEPARTMENT OR THE COUNTY.
- TWO WEEKS PRIOR TO PLACEMENT OF PERMANENT PAVEMENT MARKINGS ON ARTERIAL ROADS THE ENGINEER SHALL CONTACT MR. ERIC CAMPOS, IDOT/ARTERIAL SECTION/WILL COUNTY AREA TRAFFIC FIELD ENGINEER VIA EMAIL AT ERIC.CAMPOS@ILLINOIS.GOV AND EXPRESSWAY AREA ENGINEER AT (847) 705-4153.
- WHERE SECTION OR SUBSECTION MONUMENTS ARE ENCOUNTERED, THE ENGINEER SHALL BE NOTIFIED BEFORE SUCH MONUMENTS ARE REMOVED. THE CONTRACTOR SHALL CAREFULLY PRESERVE ALL PROPERTY MARKERS AND MONUMENTS UNTIL THE OWNER, AN AUTHORIZED SURVEYOR OR AGENT HAS WITNESSED OR OTHERWISE REFERENCED EACH LOCATION.
- THE LOCATIONS OF EXISTING UTILITIES SHOWN ON THE PLANS ARE BASED ON FIELD INVESTIGATIONS AND BEST INFORMATION AVAILABLE, BUT THEY ARE NOT GUARANTEED. IT SHALL BE THE CONTRACTOR'S RESPONSIBILITY TO ASCERTAIN THEIR EXACT LOCATIONS FROM THE UTILITY COMPANIES AND BY FIELD INSPECTION.
- THE CONTRACTOR SHALL TAKE CARE IN REMOVING OR EXCAVATING NEAR ALL EXISTING ITEMS WHICH WILL REMAIN. ANY DAMAGE DONE TO EXISTING ITEMS BY THE CONTRACTOR SHALL BE REPAIRED AT THE CONTRACTOR'S EXPENSE.
- POLLUTION CONTROL: THE CONTRACTOR SHALL BE REQUIRED TO COMPLY WITH STATE REGULATIONS REGARDING AIR, WATER AND NOISE POLLUTION.
- THE CONTRACTOR WILL BE REQUIRED TO RELOCATE OR REMOVE AND REPLACE ALL ROAD SIGNS WHICH INTERFERE WITH CONSTRUCTION OPERATIONS AND TO TEMPORARILY RESET ALL SUCH SIGNS DURING ALL STAGES OF CONSTRUCTION. THIS WORK SHALL BE INCLUDED IN THE CONTRACT UNIT PRICE FOR TRAFFIC CONTROL AND PROTECTION, (SPECIAL). ALL WORK INVOLVING SIGNS SHALL BE GOVERNED BY THE FOLLOWING:
  - SIGNS SHALL NOT BE REMOVED UNTIL NECESSITATED BY THE PROGRESS OF THE WORK.
  - EVERY SIGN REMOVED MUST BE RE-ERECTED AT A TEMPORARY LOCATION IN A WORKMANLIKE MANNER AND VISIBLE TO THE TRAFFIC FOR WHICH IT IS INTENDED.
  - ALL SIGNS MUST BE MAINTAINED STRAIGHT AND CLEAN FOR THE DURATION OF THE TEMPORARY SETTING.
  - ALL REMOVED SIGNS SHALL BE RETURNED TO APPROPRIATE GOVERNING BODY AS DIRECTED BY THE ENGINEER.
- THE RESIDENT ENGINEER SHALL CONTACT THE DISTRICT ONE TRAFFIC CONTROL SUPERVISOR AT KALPANA.KANNAN-HOSADURGA@ILLINOIS.GOV AND THE EXPRESSWAY TRAFFIC CONTROL SUPERVISOR AT (847) 705-4155 A MINIMUM OF 72 HOURS IN ADVANCE OF BEGINNING WORK.
- THIS PROJECT REQUIRES A US ARMY CORPS OF ENGINEERS (CORPS) 404 PERMIT. THE PERMIT ISSUED TO THE DEPARTMENT DOES NOT COVER THE IN-STREAM WORK BY THE CONTRACTOR. THEREFORE AFTERWARD, THE CONTRACTOR WILL NEED TO SUBMIT THE WORK PLAN TO THE CORPS. THE CORPS WILL NOT BE PROVIDING AN APPROVAL UNLESS STATED OTHERWISE IN THE PERMIT AND IN-STREAM WORK CAN COMMENCE AT THE CONTRACTOR'S DISCRETION. GUIDELINES ON ACCEPTABLE IN-STREAM WORK TECHNIQUES CAN BE FOUND ON THE CORPS WEBSITE. [HTTP://WWW.LRC.USACE.ARMY.MIL/](http://www.lrc.usace.army.mil/)
- WHEN ARTIFICIAL LIGHTS ARE USED THE CONTRACTOR SHALL EXERCISE THE UTMOST PRECAUTIONS IN PREVENTING ADVERSE VISIBILITY TO THE MOTORING PUBLIC AND ADJOINING RESIDENTIAL AREAS.
- ANY AGGREGATE SUBGRADE DAMAGED BY THE CONTRACTOR'S VEHICLES AND/OR EQUIPMENT IS TO BE REMOVED AND REPLACED AS DIRECTED BY THE ENGINEER AT CONTRACTOR'S EXPENSE.
- SAW CUTS (FULL DEPTH) SHALL BE REQUIRED BETWEEN PAVEMENT, SIDEWALK, CURB AND GUTTER, MEDIAN, DRIVEWAY PAVEMENT, AND BITUMINOUS SURFACE TO BE REMOVED AND THAT TO BE LEFT IN PLACE OR AS DIRECTED BY THE ENGINEER. THE WORK WILL NOT BE PAID FOR SEPARATELY BUT SHALL BE INCLUDED IN THE COST OF REMOVAL ITEMS.
- A 10' LONG TRANSITION SHALL BE USED TO MATCH PROPOSED CURB AND GUTTER AND MEDIAN ITEMS OF WORK TO EXISTING CURB AND GUTTER AND MEDIAN IN THE FIELD. THE TRANSITION SHALL BE PAID FOR AT THE CONTRACT UNIT PRICE FOR THE PROPOSED ITEM.

## GENERAL NOTES CONTINUED

- THE CONTRACTOR IS REQUIRED TO TAKE CORES OF THE EXISTING PAVEMENT AND SHOULDERS (NOT TEMPORARY PAVEMENT) EVERY 300' +/- PRIOR TO PAVEMENT AND SHOULDER REMOVAL, FOR THE PURPOSE OF DETERMINING THE ACTUAL THICKNESS OF THE EXISTING PAVEMENT. THIS WORK WILL NOT BE PAID FOR SEPARATELY, BUT SHALL BE INCLUDED IN THE COST OF PAVEMENT REMOVAL AND PAVED SHOULDER REMOVAL.
- DURING CONSTRUCTION, AGGREGATE FOR TEMPORARY ACCESS WILL ALSO BE USED TO PROVIDE TEMPORARY RAMPS AT INTERSECTIONS, BUILDING ENTRANCES, AND AS DETERMINED BY THE ENGINEER.
- WITHIN THE LIMITS OF CONSTRUCTION THE CONTRACTOR SHALL REMOVE AND RELOCATE ALL MAILBOXES WHICH INTERFERE WITH CONSTRUCTION OPERATIONS IN ACCORDANCE WITH THE FINAL LOCATIONS OF THE MAILBOXES SHALL BE COORDINATED AND APPROVED BY THE ENGINEER.
- THE DEPARTMENT HAS NOT OBTAINED ANY PERMITS FOR OFFSITE BORROW, WASTE, USE (BWU) AREAS. PRIOR TO WORKING IN BWU AREAS, IF THE CONTRACTOR CHOOSES TO USE ACTIVITIES REQUIRING PERMITS IT IS THE CONTRACTOR'S RESPONSIBILITY TO SECURE THE PROPER PERMITS. IN ADDITION TO THE BORROW REVIEW (BDE 2289) AND USE/WASTE REVIEW (BDE 2290) SUBMITALLS, THE CONTRACTOR SHALL SUBMIT AND EROSION CONTROL AND SEDIMENT CONTROL (ESC) PLAN FOR EVERY BWU SITE TO THE DEPARTMENT FOR ACCEPTANCE. GUIDELINES FOR ACCEPTABLE BWU PRACTICES CAN BE FOUND IN SECTION II.C OF THE SWPPP. THE COST OF ALL MATERIALS AND LABOR NECESSARY TO COMPLY WITH THE ABOVE PROVISIONS PREPARE AND IMPLEMENT ESC PLANS WILL NOT BE PAID FOR SEPARATELY, BUT SHALL BE CONSIDERED AS INCLUDED IN THE UNIT BID PRICES OF THE CONTRACT AND NO ADDITIONAL COMPENSATION WILL BE ALLOWED.
- IDOT MAINTAINED EQUIPMENT IS NOT PART OF J.U.L.I.E. THE CONTRACTOR SHOULD CALL IDOT ELECTRIC/ TRAFFIC MAINTENANCE CONTRACTOR AT (773) 287-7672 FOR CABLE LOCATION SERVICE FOR IDOT MAINTAINED EQUIPMENT BEFORE THE START OF ANY WORK. THE FIRST LOCATE IS FREE. HOWEVER, REPEAT LOCATES AT THE SAME LOCATION ARE SUBJECT TO A CHARGE.
- THE AGGREGATE GRADATION FOR THE AGGREGATE SUBGRADE IMPROVEMENT 12" LOWER LIFT SHALL BE CS 1 OR RR1.

## DRAINAGE GENERAL NOTES

- THE CONTRACTOR IS RESPONSIBLE FOR MAINTAINING DRAINAGE THROUGHOUT THE CONSTRUCTION OF THIS PROJECT.
- DURING CONSTRUCTION OPERATIONS, WHENEVER LOOSE MATERIAL IS DEPOSITED IN THE FLOW LINE OF GUTTERS, DRAINAGE STRUCTURES, DITCHES, ETC SUCH THAT THE NATURAL FLOW LINE OF WATER IS OBSTRUCTED. THE LOOSE MATERIAL SHALL BE REMOVED AT THE CLOSE OF EACH WORKING DAY. AT THE CONCLUSION OF THE CONSTRUCTION OPERATIONS, ALL DRAINAGE STRUCTURES AND FLOW LINES SHALL BE FREE FROM DIRT AND DEBRIS. THE CONTRACTOR'S FAILURE TO PROVIDE THE ABOVE WILL PRECLUDE ANY POSSIBLE ADDED COMPENSATION REQUESTED DUE TO DELAYS OR UNSUITABLE MATERIAL CREATED AS A RESULT THEREOF.
- EXISTING DRAINAGE STRUCTURE LOCATION AND INVERTS SHALL BE VERIFIED IN THE FIELD PRIOR TO INSTALLATION OF THE PROPOSED DRAINAGE ITEMS.
- INVERT ELEVATIONS FOR EXISTING PIPES HAVE BEEN SHOWN ON THE PLANS WHEN SURVEY INFORMATION WAS AVAILABLE. THE CONTRACTOR SHALL VERIFY THE INVERT ELEVATIONS FOR EXISTING PIPES IN THE FIELD AT THE TIME OF CONSTRUCTION AND SHALL NOTIFY THE ENGINEER OF ANY DISCREPANCIES.
- THE CONTRACTOR SHALL DETERMINE WHEN FLAT SLAB TOPS ARE REQUIRED ON INLETS, MANHOLES, AND CATCH BASINS. NO ADDITIONAL COMPENSATION SHALL BE ALLOWED FOR THE USE OF FLAT SLAB TOPS.
- THE ADJUSTMENT OF FRAMES ON ALL NEW STRUCTURES TO THE FINAL ELEVATION SHALL BE INCLUDED IN THE COST OF THE PROPOSED STRUCTURE.
- THE LOCATION OF EXISTING DRAINAGE STRUCTURES, STORM SEWERS, WATER MAINS, SANITARY SEWERS, AND ANY OTHER PUBLIC OR PRIVATE UTILITIES AS SHOWN ON THE PLANS IS APPROXIMATE, AND THEIR EXACT LOCATION IS TO BE DETERMINED IN THE FIELD BY THE CONTRACTOR.
- THE STATION, OFFSET, AND ELEVATION NOTED FOR DRAINAGE STRUCTURES LOCATED IN THE CURB LINE REFER TO THE POSITION OF THE ADJACENT PROPOSED EDGE OF PAVEMENT. ALL OTHER DRAINAGE STRUCTURES STATIONS AND OFFSETS ARE TO THE CENTER OF THE STRUCTURE.
- ALL FIELD TILES ENCOUNTERED SHALL BE CAREFULLY PRESERVED AND CONNECTED TO PROPOSED DRAINAGE STRUCTURES, SEWERS, OR DITCHES, AS DIRECTED BY THE ENGINEER. THIS WORK SHALL BE INCLUDED IN THE COST OF THE STORM SEWER OR STRUCTURE BEING CONSTRUCTED.
- ALL ABANDONED SEWER INVERTS SHALL BE PLUGGED WITH BRICK AND CLASS SI CONCRETE TO THE SATISFACTION OF THE ENGINEER. THIS WORK SHALL BE INCLUDED IN THE COST OF THE STORM SEWER BEING REMOVED.
- CONNECTION OF EXISTING STORM SEWER INTO PROPOSED STORM SEWER STRUCTURES SHALL BE INCLUDED IN THE COST OF THE STORM SEWER STRUCTURE. ANY ADDITIONAL STORM SEWER PIPE REQUIRED TO MAKE THE CONNECTION SHALL BE OF THE SAME SIZE AND MATERIAL TYPE AS THE EXISTING STORM SEWER AND SHALL BE INCLUDED IN THE COST OF THE DRAINAGE STRUCTURE.
- THE COST OF MAKING STORM SEWER CONNECTIONS TO EXISTING OR PROPOSED SEWER OR DRAINAGE STRUCTURES SHALL BE INCLUDED IN THE COST OF THE STORM SEWER BEING CONNECTED.
- PIPE UNDERDRAINS SHALL BE INSTALLED ACCORDING TO SECTION 601 OF THE SSRBC AND STANDARD 601001-05. TOP OF PIPE UNDERDRAINS SHALL BE PLACED MINIMUM 6" BELOW THE AGGREGATE SUBGRADE IMPROVEMENT LAYER. THE COST OF MAKING PIPE UNDERDRAIN CONNECTIONS TO DRAINAGE STRUCTURES SHALL BE INCLUDED IN THE COST OF THE PIPE UNDERDRAINS.
- THE PAY ITEM EXPLORATION TRENCH 52" HAS BEEN PROVIDED FOR PURPOSES OF LOCATING EXISTING FIELD TILE SYSTEMS. CONTRACTOR SHALL USE THIS ITEM ONLY FOR LOCATING FIELD TILE SYSTEMS.
- BACKFILLING STORM SEWER CONSTRUCTED UNDER THE ROADWAY SPECIFIED UNDER ART. 550.07(b,c) OF THE SSRBC WILL NOT BE ALLOWED.

## COMMITMENTS

- MAINTAIN SITE SCREEN EARTH BERM LOCATED AT THE SOUTH WEST CORNER OF IL 59 AND SEIL RD. THE BERM IS ON IDOT PROPERTY BUT PROVIDES SCREENING OF THE WILL COUNTY HUMANE SOCIETY ANIMAL KENNEL BUILDING. DISTURBANCE OF THE EARTH BERM SHALL BE KEPT TO A MINIMUM WHEN CONSTRUCTING THE DOUBLE 5' X 3' BOX CULVERT.

MODEL: Default  
 FILE: M:\MFC\_Plan\benesch-plan\benesch-plan\benesch-plan\Documents\107005\107040\_001\Eng\_Docs\_Phase II\General\162H15-rlc-gemmate-02.dgn  
 D:\162H15-rlc-gemmate-02.dgn  
 50107 17  
 2012/11/30



USER NAME = jworthington	DESIGNED - NREYNOLDS	REVISED -
	DRAWN - JWORTHINGTON	REVISED -
PLOT SCALE = 240,0000 ' / ft.	CHECKED - POBRIEN	REVISED -
PLOT DATE = 2/8/2022	DATE - 02/04/2022	REVISED -

### STATE OF ILLINOIS DEPARTMENT OF TRANSPORTATION

### GENERAL NOTES AND COMMITMENTS

SCALE: NONE SHEET OF SHEETS STA. TO STA.

F.A./P RTE.	SECTION	COUNTY	TOTAL SHEETS	SHEET NO.
*	2018-075-R	WILL	1510	6
CONTRACT NO. 62H15				
* FAI 55, FAP 338		ILLINOIS	FED. AID PROJECT	

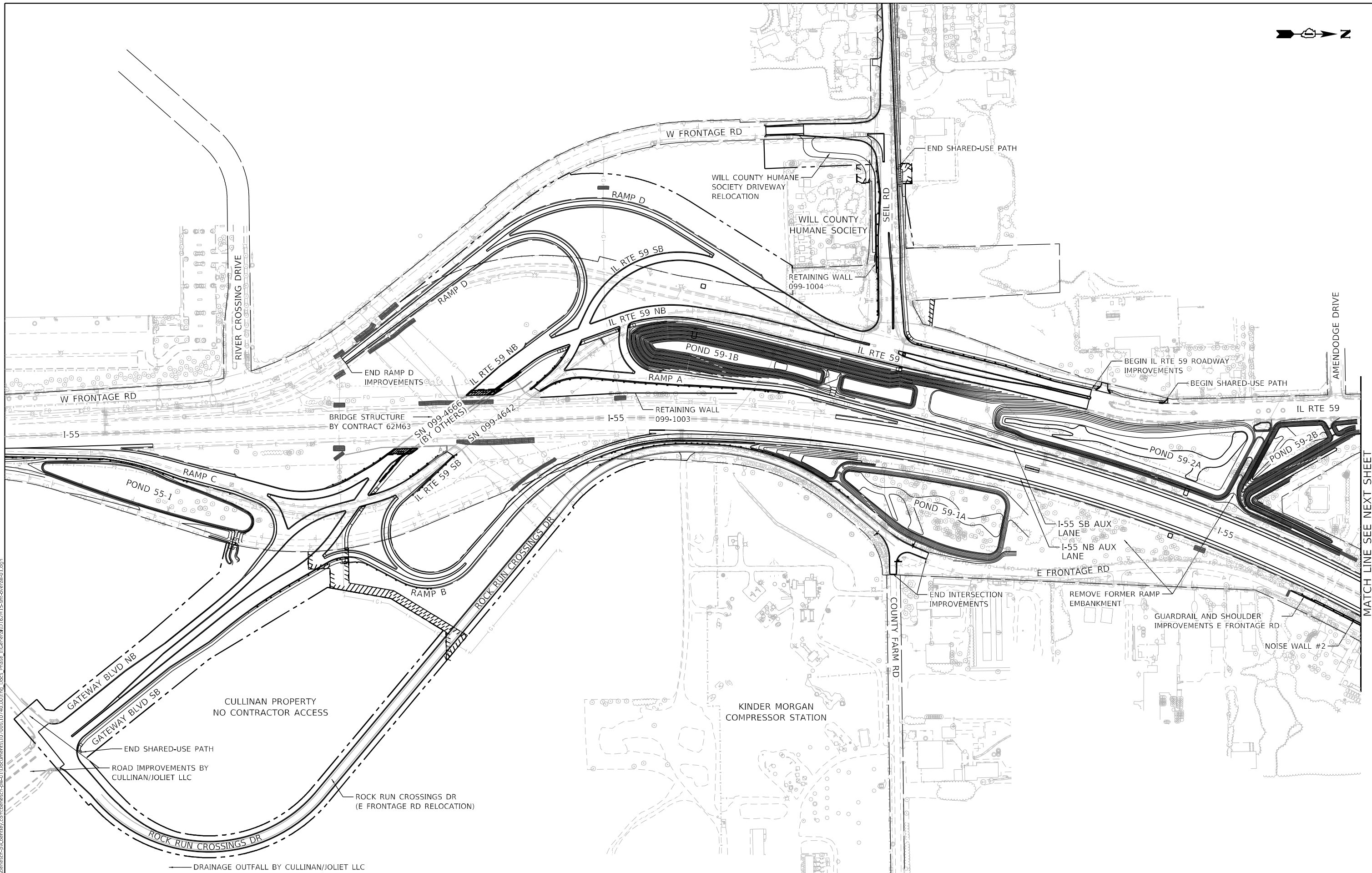
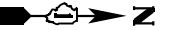

MATCH LINE SEE NEXT SHEET

MODEL: Default  
 FILE: \\nailes\pub\benesch-pw\benesch.com\benesch\pww\Documents\107005\107040\001\Eng\_Docs\_Phase II\General\107040\15-FR-overall-01.dgn  
 D:\162H15-shi-overall-01.dgn  
 50.107  
 2012/11/30



USER NAME = jworthington	DESIGNED - NREYNOLDS	REVISED -
	DRAWN - JWORTHINGTON	REVISED -
PLOT SCALE = 3840,0000' / ft.	CHECKED - POBRIEN	REVISED -
PLOT DATE = 2/1/2022	DATE - 02/04/2022	REVISED -

**STATE OF ILLINOIS  
DEPARTMENT OF TRANSPORTATION**

**OVERALL PLAN REFERENCE**

SCALE: NTS      SHEET      OF      SHEETS      STA.      TO      STA.

F.A./P RTE.	SECTION	COUNTY	TOTAL SHEETS	SHEET NO.
	2018-075-R	WILL	1510	7
CONTRACT NO. 62H15				
F AI 55, FAP 338 ILLINOIS FED. AID PROJECT				

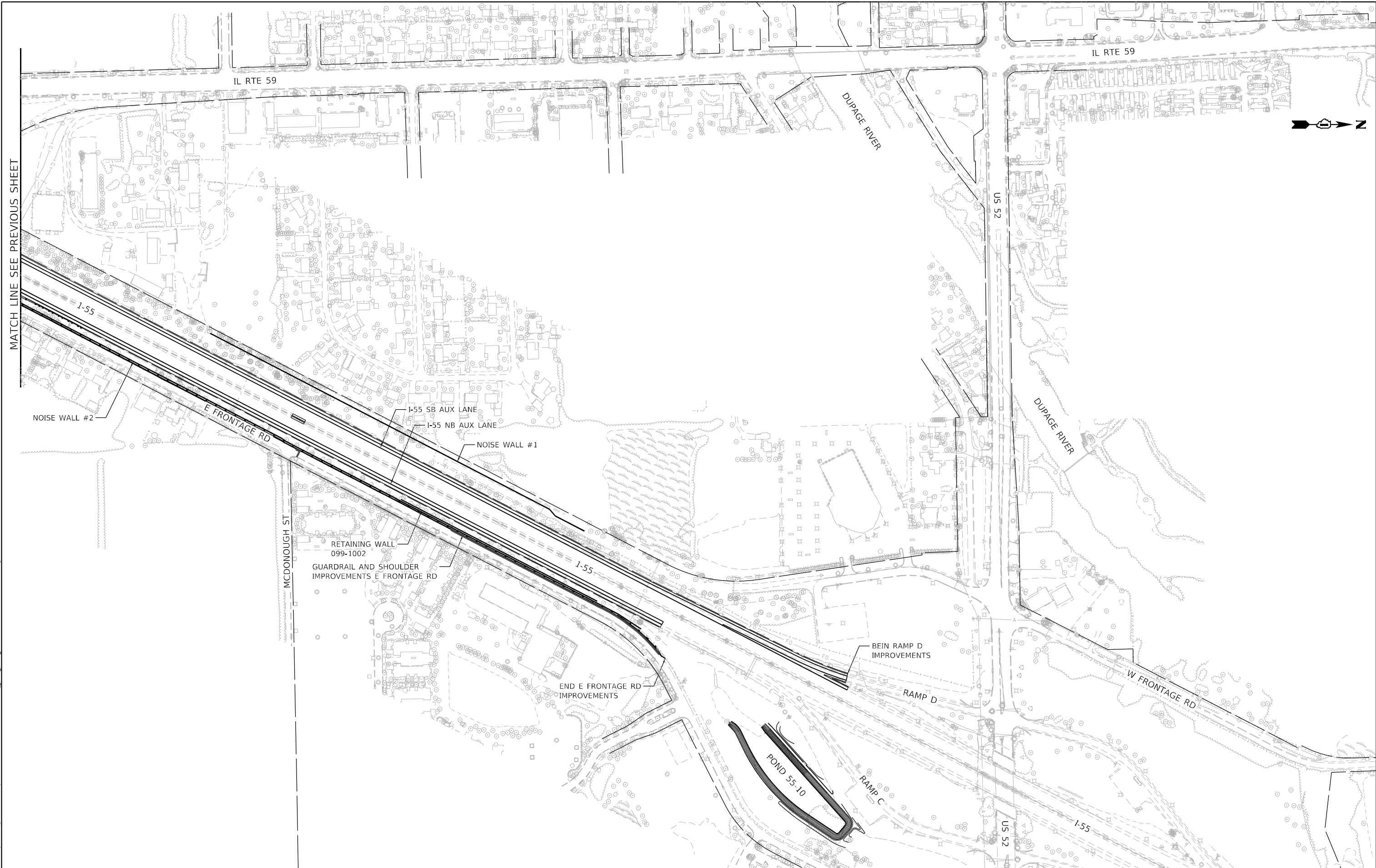

MATCH LINE SEE PREVIOUS SHEET



MODEL: Default  
 FILE: \\bentley.com\benesch\p01\Documents\107005\107040\_001\Eng\_Docs\_Phase II\General\162H15-shi-overall-02.dgn  
 D:\162H15-shi-overall-02.dgn  
 50107  
 2012/11/30



USER NAME = jworthington
PLOT SCALE = 3840,0000 ' / ft.
PLOT DATE = 2/1/2022

DESIGNED - NREYNOLDS
DRAWN - JWORTHINGTON
CHECKED - POBRIEN
DATE - 02/04/2022

REVISED -
REVISED -
REVISED -
REVISED -

**STATE OF ILLINOIS  
DEPARTMENT OF TRANSPORTATION**

**OVERALL PLAN REFERENCE**

SCALE: NTS      SHEET      OF      SHEETS      STA.      TO      STA.

F.A./P RTE.	SECTION	COUNTY	TOTAL SHEETS	SHEET NO.
-	2018-075-R	WILL	1510	8
CONTRACT NO. 62H15				
* FAI 55, FAP 338   ILLINOIS   FED. AID PROJECT				



CODE NO.	ITEM DESCRIPTION	UNIT	TOTAL QUANTITY	ROADWAY URBAN			ROADWAY LIGHTING		LED STREET SIGNS SHARED-USE PATH	OVERHEAD SIGNING	OVERHEAD SIGNING	RETAINING WALLS 099-1002 099-1003 099-1004	BRIDGE SN 099-4642	BRIDGE SN 099-4666	EMERGENCY VEHICLE PREEMPTION		TRAFFIC SIGNALS			SHARED-USE PATH	
				0004	0004	0004	IL 59	INTERCHANGE	SEIL ROAD	GATEWAY BOULEVARD	RAMP C				SEIL ROAD	DDI	INTERCONNECT		SEIL ROAD		DDI
				100% STATE	80% FED 20% STATE	100% JOLIET	100% SHOREWOOD	100% STATE	100% SHOREWOOD	100% JOLIET	50% STATE 50% JOLIET				100% STATE	100% STATE	100% STATE	100% JOLIET	100% STATE		100% JOLIET
X 20100110	TREE REMOVAL (6 TO 15 UNITS DIAMETER)	UNIT	4,273	4,273																	
X 20100210	TREE REMOVAL (OVER 15 UNITS DIAMETER)	UNIT	1,177	1,177																	
X 20100500	TREE REMOVAL, ACRES	ACRE	3.00	3.00																	
20101000	TEMPORARY FENCE	FOOT	1,912	1,912																	
X 20101200	TREE ROOT PRUNING	EACH	15	15																	
X 20101300	TREE PRUNING (1 TO 10 INCH DIAMETER)	EACH	15	15																	
X 20101350	TREE PRUNING (OVER 10 INCH DIAMETER)	EACH	29	29																	
20200100	EARTH EXCAVATION	CU YD	152,024.0		141,734.0	10,290.0															
20201200	REMOVAL AND DISPOSAL OF UNSUITABLE MATERIAL	CU YD	37,950.0		34,325.0	3,625.0															
20400800	FURNISHED EXCAVATION	CU YD	284,414.0		174,310.0	110,104.0															
20700220	POROUS GRANULAR EMBANKMENT	CU YD	348.0	348.0																	
20800150	TRENCH BACKFILL	CU YD	7,411.0	3,239.0		4,172.0															
21001000	GEOTECHNICAL FABRIC FOR GROUND STABILIZATION	SQ YD	54,252	45,990		8,262															
21101505	TOPSOIL EXCAVATION AND PLACEMENT	CU YD	106,014.0		87,712.0	18,302.0															
21301052	EXPLORATION TRENCH 52" DEPTH	FOOT	400	400																	
21301084	EXPLORATION TRENCH 84" DEPTH	FOOT	400	400																	

MODEL: D:\default\benesch\pwr\1622115\10140.dwg; Phase: D:\default\1622115\10140.dwg; Doc: Phase: D:\default\1622115\10140.dwg; Job No: 10740



USER NAME = dlevin	DESIGNED - NDAUER	REVISED -
PLOT SCALE = 24.0000' / ft.	DRAWN - NDAUER	REVISED -
PLOT DATE = 3/22/2022	CHECKED - POBRIEN	REVISED -
	DATE - 03/17/2022	REVISED -

**STATE OF ILLINOIS**  
**DEPARTMENT OF TRANSPORTATION**

SCALE:				SHEET	OF	SHEETS	STA.	TO	STA.
--------	--	--	--	-------	----	--------	------	----	------

**SUMMARY OF QUANTITIES**

F.A./P.RTE.	SECTION	COUNTY	TOTAL SHEETS	SHEET NO.
*	2018-075-R	WILL	1510	9
* FAI 55, FAP 338			ILLINOIS FED. AID PROJECT	

CODE NO.	ITEM DESCRIPTION	UNIT	TOTAL QUANTITY	ROADWAY URBAN			ROADWAY LIGHTING		LED STREET SIGNS SHARED-USE PATH	OVERHEAD SIGNING	OVERHEAD SIGNING	RETAINING WALLS 099-1002 099-1003 099-1004	BRIDGE SN 099-4642	BRIDGE SN 099-4666	EMERGENCY VEHICLE PREEMPTION		TRAFFIC SIGNALS			SHARED-USE PATH	
				0004	0004	0004	IL 59	INTERCHANGE	SEIL ROAD	GATEWAY BOULEVARD	RAMP C				SEIL ROAD	DDI	INTERCONNECT		SEIL ROAD		DDI
				100% STATE	80% FED 20% STATE	100% JOLIET	100% SHOREWOOD	100% STATE	100% SHOREWOOD	100% JOLIET	50% STATE 50% JOLIET				100% STATE	100% STATE	100% SHOREWOOD	100% JOLIET	100% STATE		100% JOLIET
X 25000110	SEEDING, CLASS 1A	ACRE	1.25	1.25																	
X 25000210	SEEDING, CLASS 2A	ACRE	10.00	4.25		5.75															
X 25000310	SEEDING, CLASS 4	ACRE	2.25	2.25																	
X 25000312	SEEDING, CLASS 4A	ACRE	50.00	45.25		4.75															
X 25000314	SEEDING, CLASS 4B	ACRE	11.00	11.00																	
X 25000400	NITROGEN FERTILIZER NUTRIENT	POUND	985	474		511															
X 25000600	POTASSIUM FERTILIZER NUTRIENT	POUND	985	474		511															
25000750	MOWING	ACRE	126.00	105.00		21.00															
25100115	MULCH, METHOD 2	ACRE	0.75	0.50		0.25															
X 25100630	EROSION CONTROL BLANKET	SQ YD	304,128	253,554		50,574															
X 25100635	HEAVY DUTY EROSION CONTROL BLANKET	SQ YD	9,637	4,290		5,347															
28000250	TEMPORARY EROSION CONTROL SEEDING	POUND	9,274	8,069		1,205															
28000305	TEMPORARY DITCH CHECKS	FOOT	3,200	2,830		370															
28000315	AGGREGATE DITCH CHECKS	TON	18	18																	
28000400	PERIMETER EROSION BARRIER	FOOT	9,753	4,646		5,107															
28000500	INLET AND PIPE PROTECTION	EACH	67	51		16															

MODEL: Default  
 FILE: \\benedsch-pw-bentley.com\benesch\pww\1\Documents\1\0705\10740\_001\Eng\_Docs\_Phase II\General\162H115-shs-soq-02.dgn



USER NAME = dlevin	DESIGNED - NDAUER	REVISED -
PLOT SCALE = 24,0000 * / ft.	DRAWN - NDAUER	REVISED -
PLOT DATE = 3/22/2022	CHECKED - POBRIEN	REVISED -
	DATE - 03/17/2022	REVISED -

**STATE OF ILLINOIS  
 DEPARTMENT OF TRANSPORTATION**

**SUMMARY OF QUANTITIES**

SCALE: SHEET OF SHEETS STA. TO STA.

F.A./P RTE.	SECTION	COUNTY	TOTAL SHEETS	SHEET NO.
*	2018-075-R	WILL	1510	10
CONTRACT NO. 62H15				
* FAI 55, FAP 338 ILLINOIS FED. AID PROJECT				

CODE NO.	ITEM DESCRIPTION	UNIT	TOTAL QUANTITY	ROADWAY URBAN			ROADWAY LIGHTING		LED STREET SIGNS SHARED-USE PATH	OVERHEAD SIGNING	OVERHEAD SIGNING	RETAINING WALLS 099-1002 099-1003 099-1004	BRIDGE SN 099-4642	BRIDGE SN 099-4666	EMERGENCY VEHICLE PREEMPTION		TRAFFIC SIGNALS			SHARED-USE PATH	
				0004	0004	0004	IL 59	INTERCHANGE	SEIL ROAD	GATEWAY BOULEVARD	RAMP C				SEIL ROAD	DDI	INTERCONNECT		SEIL ROAD		DDI
				100% STATE	80% FED 20% STATE	100% JOLIET	100% SHOREWOOD	100% STATE	100% SHOREWOOD	100% JOLIET	50% STATE 50% JOLIET				100% STATE	100% STATE	100% SHOREWOOD	100% JOLIET	100% STATE		100% JOLIET
28000510	INLET FILTERS	EACH	348	236		112															
28001100	TEMPORARY EROSION CONTROL BLANKET	SQ YD	448,841	390,528		58,313															
28100105	STONE RIPRAP, CLASS A3	SQ YD	1,684	1,366		318															
28100107	STONE RIPRAP, CLASS A4	SQ YD	3,234	2,898		336															
28100109	STONE RIPRAP, CLASS A5	SQ YD	385	385																	
28200200	FILTER FABRIC	SQ YD	5,302	4,648		654															
30300001	AGGREGATE SUBGRADE IMPROVEMENT	CU YD	37,950.0		34,325.0	3,625.0															
30300112	AGGREGATE SUBGRADE IMPROVEMENT 12"	SQ YD	131,733		95,487	36,246															
31101200	SUBBASE GRANULAR MATERIAL, TYPE B 4'	SQ YD	12,700	12,581		119															
31101400	SUBBASE GRANULAR MATERIAL, TYPE B 6'	SQ YD	4,448						710												3,738
35600704	HOT-MIX ASPHALT BASE COURSE WIDENING, 7"	SQ YD	104			104															
35600709	HOT-MIX ASPHALT BASE COURSE WIDENING, 8 1/4"	SQ YD	83	83																	
40600275	BITUMINOUS MATERIALS (PRIME COAT)	POUND	10,008						1,597												8,411
40600290	BITUMINOUS MATERIALS (TACK COAT)	POUND	1,001						160												841
40600370	LONGITUDINAL JOINT SEALANT	FOOT	73,620	47,612		26,008															
40600982	HOT-MIX ASPHALT SURFACE REMOVAL - BUTT JOINT	SQ YD	125	95		30															

MODEL: Default  
 FILE NAME: p:\benesch-pw\benesch-pw\benesch-pw\Documents\10700510740\_001\Eng\_Docs\_Phase II\General\162H15-shi-soq-03.dgn



USER NAME = dlevin	DESIGNED -	REVISED -
PLOT SCALE = 24,0000 * / ft.	DRAWN -	REVISED -
PLOT DATE = 3/22/2022	CHECKED -	REVISED -
	DATE - 03/17/2022	REVISED -

**STATE OF ILLINOIS  
 DEPARTMENT OF TRANSPORTATION**

**SUMMARY OF QUANTITIES**

SCALE: SHEET OF SHEETS STA. TO STA.

F.A./P RTE.	SECTION	COUNTY	TOTAL SHEETS	SHEET NO.
*	2018-075-R	WILL	1510	11
CONTRACT NO. 62H15				
* FAI 55, FAP 338 ILLINOIS FED. AID PROJECT				

CODE NO.	ITEM DESCRIPTION	UNIT	TOTAL QUANTITY	ROADWAY URBAN			ROADWAY LIGHTING		LED STREET SIGNS SHARED-USE PATH	OVERHEAD SIGNING	OVERHEAD SIGNING	RETAINING WALLS 099-1002 099-1003 099-1004	BRIDGE SN 099-4642	BRIDGE SN 099-4666	EMERGENCY VEHICLE PREEMPTION		TRAFFIC SIGNALS			SHARED-USE PATH	
				0004	0004	0004	IL 59	INTERCHANGE	SEIL ROAD	GATEWAY BOULEVARD	RAMP C				SEIL ROAD	DDI	INTERCONNECT		SEIL ROAD		DDI
				100% STATE	80% FED 20% STATE	100% JOLIET	100% SHOREWOOD	100% STATE	100% SHOREWOOD	100% JOLIET	50% STATE 50% JOLIET				100% STATE	100% STATE	100% SHOREWOOD	100% JOLIET	100% STATE		100% JOLIET
40603080	HOT-MIX ASPHALT BINDER COURSE, IL-19.0, N50	TON	622																		523
40604060	HOT-MIX ASPHALT SURFACE COURSE, IL-9.5, MIX "D", N50	TON	373																		313
40604062	HOT-MIX ASPHALT SURFACE COURSE, IL-9.5, MIX "D", N70	TON	1,200	1,200																	
40604172	POLYMERIZED HOT-MIX ASPHALT SURFACE COURSE, IL-9.5, MIX "E", N70	TON	49	49																	
40700100	BITUMINOUS MATERIALS (TACK COAT)	POUND	56,852	45,527		11,325															
40701861	HOT-MIX ASPHALT PAVEMENT (FULL-DEPTH), 9"	SQ YD	13,945			13,945															
40701886	HOT-MIX ASPHALT PAVEMENT (FULL-DEPTH), 10 1/4"	SQ YD	8,503		8,503																
40701936	HOT-MIX ASPHALT PAVEMENT (FULL-DEPTH), 12 3/4"	SQ YD	14,295		13,360	935															
40701981	HOT-MIX ASPHALT PAVEMENT (FULL-DEPTH), 15"	SQ YD	12,147		12,147																
42000060	WELDED WIRE REINFORCEMENT	SQ YD	527	527																	
42000080	PAVEMENT CONNECTOR (PCC) FOR BRIDGE APPROACH SLAB	SQ YD	527	527																	
42000501	PORTLAND CEMENT CONCRETE PAVEMENT 10" (JOINTED)	SQ YD	42,796		29,249	13,547															
42001300	PROTECTIVE COAT	SQ YD	59,425	38,812		19,185															1,428
42300400	PORTLAND CEMENT CONCRETE DRIVEWAY PAVEMENT, 8 INCH	SQ YD	110	110																	
42400200	PORTLAND CEMENT CONCRETE SIDEWALK 5 INCH	SQ FT	12,216																		12,216
42400410	PORTLAND CEMENT CONCRETE SIDEWALK 8 INCH	SQ FT	640																		640

MODEL: Default  
 FILE NAME: p:\benesch-ar\benesch-ar\benesch-ar\Documents\10700510740\_001\Eng\_Docs\_Phase II\General\162H115-shs-soq-04.dgn



USER NAME = dlevin  
 DESIGNED -  
 DRAWN -  
 PLOT SCALE = 24,0000 \* / ft.  
 CHECKED -  
 PLOT DATE = 3/22/2022  
 DATE = 03/17/2022  
 REVISED -  
 REVISED -  
 REVISED -  
 REVISED -

**STATE OF ILLINOIS  
 DEPARTMENT OF TRANSPORTATION**

**SUMMARY OF QUANTITIES**

SCALE: SHEET OF SHEETS STA. TO STA.

F.A./P RTE.	SECTION	COUNTY	TOTAL SHEETS	SHEET NO.
*	2018-075-R	WILL	1510	12
CONTRACT NO. 62H15				
* FAI 55, FAP 338 ILLINOIS FED. AID PROJECT				

CODE NO.	ITEM DESCRIPTION	UNIT	TOTAL QUANTITY	ROADWAY URBAN			ROADWAY LIGHTING		LED STREET SIGNS SHARED-USE PATH	OVERHEAD SIGNING	OVERHEAD SIGNING	RETAINING WALLS 099-1002 099-1003 099-1004	BRIDGE SN 099-4642	BRIDGE SN 099-4666	EMERGENCY VEHICLE PREEMPTION		TRAFFIC SIGNALS			SHARED-USE PATH	
				0004	0004	0004	IL 59	INTERCHANGE	SEIL ROAD	GATEWAY BOULEVARD	RAMP C				SEIL ROAD	DDI	INTERCONNECT		SEIL ROAD		DDI
				100% STATE	80% FED 20% STATE	100% JOLIET	100% SHOREWOOD	100% STATE	100% SHOREWOOD	100% JOLIET	50% STATE 50% JOLIET				100% STATE	100% STATE	100% SHOREWOOD	100% JOLIET	100% STATE		100% JOLIET
42400800	DETECTABLE WARNINGS	SQ FT	388																		388
44000100	PAVEMENT REMOVAL	SQ YD	50,053		35,621	14,432															
44000157	HOT-MIX ASPHALT SURFACE REMOVAL, 2"	SQ YD	1,205	434		771															
44000200	DRIVEWAY PAVEMENT REMOVAL	SQ YD	1,537	923		614															
44000500	COMBINATION CURB AND GUTTER REMOVAL	FOOT	6,210	6,210																	
44001980	CONCRETE BARRIER REMOVAL	FOOT	364	364																	
44003100	MEDIAN REMOVAL	SQ FT	11,665	11,665																	
44004250	PAVED SHOULDER REMOVAL	SQ YD	21,348	21,348																	
48101620	AGGREGATE SHOULDERS, TYPE B 10"	SQ YD	5,844	5,787		57															
48203029	HOT-MIX ASPHALT SHOULDERS, 8"	SQ YD	308	308																	
48203048	HOT-MIX ASPHALT SHOULDERS, 12 3/4"	SQ YD	9,720		9,329	391															
48203057	HOT-MIX ASPHALT SHOULDERS, 15"	SQ YD	10,289		10,289																
48300500	PORTLAND CEMENT CONCRETE SHOULDERS 10"	SQ YD	3,653	2,990		663															
50102400	CONCRETE REMOVAL	CU YD	64.0								60.0	4.0									
50104400	CONCRETE HEADWALL REMOVAL	EACH	8	6		2															
50105220	PIPE CULVERT REMOVAL	FOOT	696	473		223															

MODEL: Default  
 FILE: \\benedsch-pw-bentley.com\benesch\pww\1\Documents\1\0700510740\_001\Eng\_Docs\_Phase 1\General\162H115-shi-soq-05.dgn



USER NAME = dlevin	DESIGNED -	REVISED -
PLOT SCALE = 24,0000 * / ft.	DRAWN -	REVISED -
PLOT DATE = 3/22/2022	CHECKED -	REVISED -
	DATE - 03/17/2022	REVISED -

**STATE OF ILLINOIS  
 DEPARTMENT OF TRANSPORTATION**

**SUMMARY OF QUANTITIES**

SCALE: SHEET OF SHEETS STA. TO STA.

F.A./P RTE.	SECTION	COUNTY	TOTAL SHEETS	SHEET NO.
*	2018-075-R	WILL	1510	13
CONTRACT NO. 62H15				
* FAI 55, FAP 338 ILLINOIS FED. AID PROJECT				

CODE NO.	ITEM DESCRIPTION	UNIT	TOTAL QUANTITY	ROADWAY URBAN			ROADWAY LIGHTING		LED STREET SIGNS SHARED-USE PATH	OVERHEAD SIGNING	OVERHEAD SIGNING	RETAINING WALLS 099-1002 099-1003 099-1004	BRIDGE SN 099-4642	BRIDGE SN 099-4666	EMERGENCY VEHICLE PREEMPTION		TRAFFIC SIGNALS			SHARED-USE PATH	
				URBAN			IL 59	INTERCHANGE	SEIL ROAD	GATEWAY BOULEVARD	RAMP C				SEIL ROAD	DDI	INTERCONNECT	SEIL ROAD	DDI		
				100% STATE	80% FED 20% STATE	100% JOLIET	0021 SHOREWOOD	0021 STATE	0021 SHOREWOOD	0004 JOLIET	0004 STATE 50% JOLIET				0044 STATE	0010 STATE	0010 STATE	0021 SHOREWOOD	0021 JOLIET		0021 STATE
50200100	STRUCTURE EXCAVATION	CU YD	7,313.0	3,410.0							3,884.0	19.0									
50200400	ROCK EXCAVATION FOR STRUCTURES	CU YD	7.5	7.5																	
50200450	REMOVAL AND DISPOSAL OF UNSUITABLE MATERIAL FOR STRUCTURES	CU YD	462.0	168.0							294.0										
50201101	COFFERDAM (TYPE 1) (LOCATION - 1)	EACH	1	1																	
50300225	CONCRETE STRUCTURES	CU YD	396.7	22.7							314.7		59.3								
50300255	CONCRETE SUPERSTRUCTURE	CU YD	60.7									27.5	33.2								
50300260	BRIDGE DECK GROOVING	SQ YD	266										266								
50300285	FORM LINER TEXTURED SURFACE	SQ FT	6,878								6,878										
50300300	PROTECTIVE COAT	SQ YD	1,336								855	44	437								
50500505	STUD SHEAR CONNECTORS	EACH	7,594								7,594										
50800205	REINFORCEMENT BARS, EPOXY COATED	POUND	248,520.0	140,370.0							82,080	3,210.0	22,860								
50901739	BRIDGE FENCE RAILING, CURVED	FOOT	436										436								
50901750	PARAPET RAILING	FOOT	604	205									399								
51500100	NAME PLATES	EACH	3								3										
52000110	PREFORMED JOINT STRIP SEAL	FOOT	190										190								
52200020	TEMPORARY SOIL RETENTION SYSTEM	SQ FT	6,992	5,155							1,837										

MODEL: D:\default\benesch\pwr\benesch\pwr\3D\Documents\107200\107200\107200.dwg Phase 1\General\107200\107200.dwg  
 FILE NAME: pwr\benesch\pwr\benesch\pwr\3D\Documents\107200\107200\107200.dwg Phase 1\General\107200\107200.dwg



USER NAME = dlevin	DESIGNED -	REVISED -
PLOT SCALE = 24.0000' / ft.	DRAWN -	REVISED -
PLOT DATE = 3/22/2022	CHECKED -	REVISED -
	DATE = 03/17/2022	REVISED -

**STATE OF ILLINOIS**  
**DEPARTMENT OF TRANSPORTATION**

SUMMARY OF QUANTITIES				
SCALE:	SHEET	OF	SHEETS	STA. TO STA.

F.A./P.RTE.	SECTION	COUNTY	TOTAL SHEETS	SHEET NO.
*	2018-075-R	WILL	1510	14
			CONTRACT NO. 62H15	
* FAI 55, FAP 338		ILLINOIS	FED. AID PROJECT	

D162H15.sht-soa-06.dgn  
 50107  
 2012/11/30

REV-SEP

CODE NO.	ITEM DESCRIPTION	UNIT	TOTAL QUANTITY	ROADWAY URBAN			ROADWAY LIGHTING		LED STREET SIGNS SHARED-USE PATH	OVERHEAD SIGNING	OVERHEAD SIGNING	RETAINING WALLS 099-1002 099-1003 099-1004	BRIDGE SN 099-4642	BRIDGE SN 099-4666	EMERGENCY VEHICLE PREEMPTION		TRAFFIC SIGNALS			SHARED-USE PATH	
				0004	0004	0004	IL 59	INTERCHANGE	SEIL ROAD	GATEWAY BOULEVARD	RAMP C				SEIL ROAD	DDI	INTERCONNECT		SEIL ROAD		DDI
				100% STATE	80% FED 20% STATE	100% JOLIET	100% SHOREWOOD	100% STATE	100% SHOREWOOD	100% JOLIET	50% STATE 50% JOLIET				100% STATE	100% STATE	100% SHOREWOOD	100% JOLIET	100% STATE		100% JOLIET
52200100	FURNISHING SOLDIER PILES (HP SECTION)	FOOT	6,164																		
52200150	DRIVING SOLDIER PILES	FOOT	6,164																		
52200250	UNTREATED TIMBER LAGGING	SQ FT	8,498																		
52200500	MECHANICALLY STABILIZED EARTH RETAINING WALL	SQ FT	10,717																		
54001001	BOX CULVERT END SECTIONS, CULVERT NO. 1	EACH	4	4																	
54001002	BOX CULVERT END SECTIONS, CULVERT NO. 2	EACH	4	4																	
54010502	PRECAST CONCRETE BOX CULVERTS 5' X 2'	FOOT	152	152																	
54010503	PRECAST CONCRETE BOX CULVERTS 5' X 3'	FOOT	488		488																
542A0223	PIPE CULVERTS, CLASS A, TYPE 1 18"	FOOT	134	134																	
542A0229	PIPE CULVERTS, CLASS A, TYPE 1 24"	FOOT	453	453																	
542A0235	PIPE CULVERTS, CLASS A, TYPE 1 30"	FOOT	13	13																	
542A0247	PIPE CULVERTS, CLASS A, TYPE 1 42"	FOOT	13	13																	
542A1069	PIPE CULVERTS, CLASS A, TYPE 2 24"	FOOT	213	135																	
542A1075	PIPE CULVERTS, CLASS A, TYPE 2 30"	FOOT	293	220																	
542A1087	PIPE CULVERTS, CLASS A, TYPE 2 42"	FOOT	150	150																	
542A1093	PIPE CULVERTS, CLASS A, TYPE 2 48"	FOOT	49	49																	

MODEL: Default  
 FILE: M:\E:\p\benesch-pw\benesch-pw\Documents\10705\10705-10740-001\Eng\_Docs\_Phase II\General\162H15-shi-soq-07.dgn



USER NAME = dlevin	DESIGNED -	REVISED -
PLOT SCALE = 24,0000 * / ft.	DRAWN -	REVISED -
PLOT DATE = 3/22/2022	CHECKED -	REVISED -
	DATE = 03/17/2022	REVISED -

**STATE OF ILLINOIS  
 DEPARTMENT OF TRANSPORTATION**

**SUMMARY OF QUANTITIES**

SCALE: SHEET OF SHEETS STA. TO STA.

F.A./P RTE.	SECTION	COUNTY	TOTAL SHEETS	SHEET NO.
*	2018-075-R	WILL	1510	15
CONTRACT NO. 62H15				
* FAI 55, FAP 338 ILLINOIS FED. AID PROJECT				

CODE NO.	ITEM DESCRIPTION	UNIT	TOTAL QUANTITY	ROADWAY URBAN			ROADWAY LIGHTING		LED STREET SIGNS SHARED-USE PATH	OVERHEAD SIGNING	OVERHEAD SIGNING	RETAINING WALLS 099-1002 099-1003 099-1004	BRIDGE SN 099-4642	BRIDGE SN 099-4666	EMERGENCY VEHICLE PREEMPTION		TRAFFIC SIGNALS			SHARED-USE PATH	
				URBAN			IL 59	INTERCHANGE	SEIL ROAD	GATEWAY BOULEVARD	RAMP C				SEIL ROAD	DDI	INTERCONNECT	SEIL ROAD	DDI		
				0004	0004	0004	0021	0021	0021	0004	0004				0044	0010	0010	0021	0021		0021
				100% STATE	80% FED 20% STATE	100% JOLIET	100% SHOREWOOD	100% STATE	100% SHOREWOOD	100% JOLIET	50% STATE 50% JOLIET	100% STATE	100% STATE	100% SHOREWOOD	100% JOLIET	100% STATE	100% JOLIET	96.7% STATE 3.3% SHOREWOOD	50% STATE 50% JOLIET	100% STATE	
542A1921	PIPE CULVERTS, CLASS A, TYPE 3 36"	FOOT	202	202																	
542A2749	PIPE CULVERTS, CLASS A, TYPE 4 24"	FOOT	147	147																	
542A2761	PIPE CULVERTS, CLASS A, TYPE 4 36"	FOOT	191			191															
542A3391	PIPE CULVERTS, CLASS A, TYPE 5 36"	FOOT	194			194															
542A5473	PIPE CULVERTS, CLASS A, TYPE 1 EQUIVALENT ROUND-SIZE 18"	FOOT	261	155		106															
542A5479	PIPE CULVERTS, CLASS A, TYPE 1 EQUIVALENT ROUND-SIZE 24"	FOOT	155	155																	
542A5485	PIPE CULVERTS, CLASS A, TYPE 1 EQUIVALENT ROUND-SIZE 30"	FOOT	181	181																	
542A5491	PIPE CULVERTS, CLASS A, TYPE 1 EQUIVALENT ROUND-SIZE 36"	FOOT	54	54																	
542A8209	PIPE CULVERTS, CLASS A, TYPE 2 EQUIVALENT ROUND-SIZE 24"	FOOT	259			259															
54213657	PRECAST REINFORCED CONCRETE FLARED END SECTIONS 12"	EACH	11	6		5															
54213663	PRECAST REINFORCED CONCRETE FLARED END SECTIONS 18"	EACH	7	7																	
54213669	PRECAST REINFORCED CONCRETE FLARED END SECTIONS 24"	EACH	1			1															
54213675	PRECAST REINFORCED CONCRETE FLARED END SECTIONS 30"	EACH	1			1															
54214503	PRECAST REINFORCED CONCRETE FLARED END SECTIONS, EQUIVALENT ROUND-SIZE 18"	EACH	5	1		4															
54214509	PRECAST REINFORCED CONCRETE FLARED END SECTIONS, EQUIVALENT ROUND-SIZE 24"	EACH	4	4																	
54214515	PRECAST REINFORCED CONCRETE FLARED END SECTIONS, EQUIVALENT ROUND-SIZE 30"	EACH	6	6																	

MODEL: D:\default\benesch\pwr-3\Documents\107200\10740\_001.dwg, Phase 3\General\107200\10740\_001.dwg  
 FILE NAME: pwr-3\benesch\pwr-3\Documents\107200\10740\_001.dwg, Phase 3\General\107200\10740\_001.dwg



USER NAME = dlevin	DESIGNED -	REVISED -
PLOT SCALE = 24.0000' / ft.	DRAWN -	REVISED -
PLOT DATE = 3/22/2022	CHECKED -	REVISED -
	DATE = 03/17/2022	REVISED -

**STATE OF ILLINOIS**  
**DEPARTMENT OF TRANSPORTATION**

SUMMARY OF QUANTITIES			
SCALE:	SHEET	OF	SHEETS
	STA.		TO STA.

F.A./P.R.T.E.	SECTION	COUNTY	TOTAL SHEETS	SHEET NO.
*	2018-075-R	WILL	1510	16
			CONTRACT NO. 62H15	
* FAI 55, FAP 338 ILLINOIS FED. AID PROJECT				



CODE NO.	ITEM DESCRIPTION	UNIT	TOTAL QUANTITY	ROADWAY URBAN			ROADWAY LIGHTING		LED STREET SIGNS SHARED-USE PATH	OVERHEAD SIGNING	OVERHEAD SIGNING	RETAINING WALLS 099-1002 099-1003 099-1004	BRIDGE SN 099-4642	BRIDGE SN 099-4666	EMERGENCY VEHICLE PREEMPTION		TRAFFIC SIGNALS			SHARED-USE PATH	
				0004	0004	0004	IL 59	INTERCHANGE	SEIL ROAD	GATEWAY BOULEVARD	RAMP C				SEIL ROAD	DDI	INTERCONNECT		SEIL ROAD		DDI
				100% STATE	80% FED 20% STATE	100% JOLIET	100% SHOREWOOD	100% STATE	100% SHOREWOOD	100% JOLIET	50% STATE 50% JOLIET				100% STATE	100% STATE	100% SHOREWOOD	100% JOLIET	100% STATE		100% JOLIET
54214521	PRECAST REINFORCED CONCRETE FLARED END SECTIONS, EQUIVALENT ROUND-SIZE 36"	EACH	4	4																	
54214527	PRECAST REINFORCED CONCRETE FLARED END SECTIONS, EQUIVALENT ROUND-SIZE 42"	EACH	1	1																	
54244405	FLUSH INLET BOX FOR MEDIAN, STANDARD 542546	EACH	1	1																	
54260315	TRAVERSABLE PIPE GRATE FOR CONCRETE END SECTION	FOOT	460	361			99														
54261318	CONCRETE END SECTION, STANDARD 542001, 18", 1:3	EACH	6	6																	
54261324	CONCRETE END SECTION, STANDARD 542001, 24", 1:3	EACH	13	11			2														
54261330	CONCRETE END SECTION, STANDARD 542001, 30", 1:3	EACH	3	3																	
54261336	CONCRETE END SECTION, STANDARD 542001, 36", 1:3	EACH	3	1			2														
54261342	CONCRETE END SECTION, STANDARD 542001, 42", 1:3	EACH	4	4																	
54261430	CONCRETE END SECTION, STANDARD 542001, 30", 1:4	EACH	1				1														
54261624	CONCRETE END SECTION, STANDARD 542001, 24", 1:6	EACH	6	6																	
54261630	CONCRETE END SECTION, STANDARD 542001, 30", 1:6	EACH	1	1																	
54263324	CONCRETE END SECTION, STANDARD 542011, 24", 1:3	EACH	7	4			3														
54263424	CONCRETE END SECTION, STANDARD 542011, 24", 1:4	EACH	3				3														
54263618	CONCRETE END SECTION, STANDARD 542011, 18", 1:6	EACH	5	5																	
550A0050	STORM SEWERS, CLASS A, TYPE 1 12"	FOOT	796	647			149														

MODEL: default  
 FILE NAME: p:\bentley\pwworking\benesch\dwg\Documents\170501\170501.dwg  
 PLOT DATE: 3/22/2022  
 PLOT SCALE: 24.0000' / ft.  
 USER NAME: dlevin  
 DESIGNED: -  
 DRAWN: -  
 CHECKED: -  
 DATE: 03/17/2022  
 REVISED: -  
 REVISED: -  
 REVISED: -  
 REVISED: -



**STATE OF ILLINOIS  
 DEPARTMENT OF TRANSPORTATION**

SUMMARY OF QUANTITIES			
SCALE:	SHEET	OF SHEETS	STA. TO STA.

F.A./P.RTE.	SECTION	COUNTY	TOTAL SHEETS	SHEET NO.
*	2018-075-R	WILL	1510	17
CONTRACT NO. 62H15				
* FAI 55, FAP 338 ILLINOIS FED. AID PROJECT				

CODE NO.	ITEM DESCRIPTION	UNIT	TOTAL QUANTITY	ROADWAY URBAN			ROADWAY LIGHTING		LED STREET SIGNS SHARED-USE PATH	OVERHEAD SIGNING	OVERHEAD SIGNING	RETAINING WALLS 099-1002 099-1003 099-1004	BRIDGE SN 099-4642	BRIDGE SN 099-4666	EMERGENCY VEHICLE PREEMPTION		TRAFFIC SIGNALS			SHARED-USE PATH	
				URBAN			IL 59	INTERCHANGE	SEIL ROAD	GATEWAY BOULEVARD	RAMP C				SEIL ROAD	DDI	INTERCONNECT		SEIL ROAD		DDI
				0004	0004	0004	0021	0021	0021	0004	0004				0044	0010	0010	0021	0021		0021
				100% STATE	80% FED 20% STATE	100% JOLIET	100% SHOREWOOD	100% STATE	100% SHOREWOOD	100% JOLIET	50% STATE 50% JOLIET	100% STATE	100% STATE	100% SHOREWOOD	100% JOLIET	100% STATE	100% JOLIET	96.7% STATE 3.3% SHOREWOOD	50% STATE 50% JOLIET	100% STATE	
550A0070	STORM SEWERS, CLASS A, TYPE 1 15"	FOOT	368	368																	
550A0090	STORM SEWERS, CLASS A, TYPE 1 18"	FOOT	125	24		101															
550A0120	STORM SEWERS, CLASS A, TYPE 1 24"	FOOT	270	66		204															
550A0340	STORM SEWERS, CLASS A, TYPE 2 12"	FOOT	8,903		5,687	3,216															
550A0360	STORM SEWERS, CLASS A, TYPE 2 15"	FOOT	1,073	925		148															
550A0380	STORM SEWERS, CLASS A, TYPE 2 18"	FOOT	993	389		604															
550A0410	STORM SEWERS, CLASS A, TYPE 2 24"	FOOT	1,439	193		1,246															
550A0430	STORM SEWERS, CLASS A, TYPE 2 30"	FOOT	1,237			1,237															
550A0450	STORM SEWERS, CLASS A, TYPE 2 36"	FOOT	577			577															
550A0500	STORM SEWERS, CLASS A, TYPE 2 60"	FOOT	56			56															
550A0680	STORM SEWERS, CLASS A, TYPE 3 18"	FOOT	97	97																	
550A1010	STORM SEWERS, CLASS A, TYPE 4 24"	FOOT	151	151																	
550A1260	STORM SEWERS, CLASS A, TYPE 5 18"	FOOT	225	225																	
550A4000	STORM SEWERS, CLASS A, TYPE 1 EQUIVALENT ROUND-SIZE 18"	FOOT	139	139																	
550A4300	STORM SEWERS, CLASS A, TYPE 1 EQUIVALENT ROUND-SIZE 30"	FOOT	172	172																	
550A4500	STORM SEWERS, CLASS A, TYPE 1 EQUIVALENT ROUND-SIZE 36"	FOOT	185	185																	

MODEL: D:\default\benesch\pwr\benesch\pwr-03\Documents\107200\107200-10-140-001.dwg, Phase 1\General\0162H15-shl-soq-10.dgn  
 FILE NAME: pwr\benesch\pwr\benesch\pwr-03\Documents\107200\107200-10-140-001.dwg, Phase 1\General\0162H15-shl-soq-10.dgn



USER NAME = dlevin	DESIGNED -	REVISED -
PLOT SCALE = 24.0000' / ft.	DRAWN -	REVISED -
PLOT DATE = 3/22/2022	CHECKED -	REVISED -
	DATE = 03/17/2022	REVISED -

**STATE OF ILLINOIS  
DEPARTMENT OF TRANSPORTATION**

**SUMMARY OF QUANTITIES**

SCALE: SHEET OF SHEETS STA. TO STA.

F.A./P.RTE.	SECTION	COUNTY	TOTAL SHEETS	SHEET NO.
*	2018-075-R	WILL	1510	18
			CONTRACT NO. 62H15	
* FAI 55, FAP 338		ILLINOIS	FED. AID PROJECT	

CODE NO.	ITEM DESCRIPTION	UNIT	TOTAL QUANTITY	ROADWAY URBAN			ROADWAY LIGHTING		LED STREET SIGNS SHARED-USE PATH	OVERHEAD SIGNING	OVERHEAD SIGNING	RETAINING WALLS 099-1002 099-1003 099-1004	BRIDGE SN 099-4642	BRIDGE SN 099-4666	EMERGENCY VEHICLE PREEMPTION		TRAFFIC SIGNALS			SHARED-USE PATH	
				0004	0004	0004	IL 59	INTERCHANGE	SEIL ROAD	GATEWAY BOULEVARD	RAMP C				SEIL ROAD	DDI	INTERCONNECT		SEIL ROAD		DDI
				100% STATE	80% FED 20% STATE	100% JOLIET	100% SHOREWOOD	100% STATE	100% SHOREWOOD	100% JOLIET	50% STATE 50% JOLIET				100% STATE	100% STATE	100% SHOREWOOD	100% JOLIET	100% STATE		100% JOLIET
550A4700	STORM SEWERS, CLASS A, TYPE 1 EQUIVALENT ROUND-SIZE 42"	FOOT	637	637																	
550A5300	STORM SEWERS, CLASS A, TYPE 2 EQUIVALENT ROUND-SIZE 36"	FOOT	11	11																	
55100500	STORM SEWER REMOVAL 12"	FOOT	1,953	1,953																	
55100700	STORM SEWER REMOVAL 15"	FOOT	1,032	1,032																	
55100900	STORM SEWER REMOVAL 18"	FOOT	542	542																	
55101100	STORM SEWER REMOVAL 21"	FOOT	244	244																	
55101200	STORM SEWER REMOVAL 24"	FOOT	263	263																	
55201500	STORM SEWERS JACKED IN PLACE, 42"	FOOT	302		302																
X 56400400	FIRE HYDRANTS TO BE RELOCATED	EACH	3	3																	
58600101	GRANULAR BACKFILL FOR STRUCTURES	CU YD	462.0	168.0							294.0										
59100100	GEOCOMPOSITE WALL DRAIN	SQ YD	1,188	394							794										
59300100	CONTROLLED LOW-STRENGTH MATERIAL	CU YD	788.8	624.9		163.9															
60100060	CONCRETE HEADWALLS FOR PIPE DRAINS	EACH	21	20		1															
60108200	PIPE UNDERDRAINS 6" (SPECIAL)	FOOT	509	494		15															
60108206	PIPE UNDERDRAINS, TYPE 2, 6"	FOOT	15,030	12,174		2,856															
60146304	PIPE UNDERDRAINS FOR STRUCTURES 4"	FOOT	810								810										

MODEL: D:\default\benesch\pwr\benesch\pwr\3Documents\107200\10740\_001ing\_Docs\_Phase 2\General\0162H15-shl-soq-11.dgn  
 FILE NAME: pwr\benesch\pwr\benesch\pwr\3Documents\107200\10740\_001ing\_Docs\_Phase 2\General\0162H15-shl-soq-11.dgn



USER NAME = dlevin	DESIGNED -	REVISED -
PLOT SCALE = 24.0000' / ft.	DRAWN -	REVISED -
PLOT DATE = 3/22/2022	CHECKED -	REVISED -
	DATE = 03/17/2022	REVISED -

**STATE OF ILLINOIS**  
**DEPARTMENT OF TRANSPORTATION**

**SUMMARY OF QUANTITIES**

SCALE: SHEET OF SHEETS STA. TO STA.

F.A./P.RTE.	SECTION	COUNTY	TOTAL SHEETS	SHEET NO.
*	2018-075-R	WILL	1510	19
			CONTRACT NO. 62H15	
* FAI 55, FAP 338		ILLINOIS FED. AID PROJECT		

D162H15.sht-soq-11.dgn  
50107  
2012/11/30

REV-SEP

CODE NO.	ITEM DESCRIPTION	UNIT	TOTAL QUANTITY	ROADWAY URBAN			ROADWAY LIGHTING		LED STREET SIGNS SHARED-USE PATH	OVERHEAD SIGNING	OVERHEAD SIGNING	RETAINING WALLS 099-1002 099-1003 099-1004	BRIDGE SN 099-4642	BRIDGE SN 099-4666	EMERGENCY VEHICLE PREEMPTION		TRAFFIC SIGNALS			SHARED-USE PATH	
				URBAN			IL 59	INTERCHANGE	SEIL ROAD	GATEWAY BOULEVARD	RAMP C				SEIL ROAD	DDI	INTERCONNECT		SEIL ROAD		DDI
				0004	0004	0004	0021	0021	0021	0004	0004				0044	0010	0010	0021	0021		0021
				100% STATE	80% FED 20% STATE	100% JOLIET	100% SHOREWOOD	100% STATE	100% SHOREWOOD	100% JOLIET	50% STATE 50% JOLIET	100% STATE	100% STATE	100% SHOREWOOD	100% JOLIET	100% STATE	100% JOLIET	96.7% STATE 3.3% SHOREWOOD	50% STATE 50% JOLIET	100% STATE	
60200805	CATCH BASINS, TYPE A, 4'-DIAMETER, TYPE 8 GRATE	EACH	16	6		10															
60201105	CATCH BASINS, TYPE A, 4'-DIAMETER, TYPE 11 FRAME AND GRATE	EACH	3			3															
60201110	CATCH BASINS, TYPE A, 4'-DIAMETER, TYPE 11V FRAME AND GRATE	EACH	3	3																	
60201205	CATCH BASINS, TYPE A, 4'-DIAMETER, TYPE 12 FRAME AND GRATE	EACH	7	7																	
60201310	CATCH BASINS, TYPE A, 4'-DIAMETER, TYPE 20 FRAME AND GRATE	EACH	3	3																	
60201340	CATCH BASINS, TYPE A, 4'-DIAMETER, TYPE 24 FRAME AND GRATE	EACH	104	55		49															
60206600	CATCH BASINS, TYPE B, TYPE 7 GRATE	EACH	2	2																	
60218400	MANHOLES, TYPE A, 4'-DIAMETER, TYPE 1 FRAME, CLOSED LID	EACH	22	19		3															
60219400	MANHOLES, TYPE A, 4'-DIAMETER, TYPE 12 FRAME AND GRATE	EACH	5	5																	
60219540	MANHOLES, TYPE A, 4'-DIAMETER, TYPE 24 FRAME AND GRATE	EACH	7	5		2															
60221100	MANHOLES, TYPE A, 5'-DIAMETER, TYPE 1 FRAME, CLOSED LID	EACH	14	2		12															
60221700	MANHOLES, TYPE A, 5'-DIAMETER, TYPE 8 GRATE	EACH	2	2																	
60222240	MANHOLES, TYPE A, 5'-DIAMETER, TYPE 24 FRAME AND GRATE	EACH	27	6		21															
60223800	MANHOLES, TYPE A, 6'-DIAMETER, TYPE 1 FRAME, CLOSED LID	EACH	4	1		3															
60224005	MANHOLES, TYPE A, 6'-DIAMETER, TYPE 8 GRATE	EACH	1	1																	
60224039	MANHOLES, TYPE A, 6'-DIAMETER, TYPE 24 FRAME AND GRATE	EACH	4	3		1															

MODEL: D:\default\benesch\pwr\benesch\pwr\3Documents\10700\10740\001ing\_Docs\_Phase 2\General\02\2115-shl-soc-12.dgn  
 FILE NAME: pwr\benesch\pwr\benesch\pwr\3Documents\10700\10740\001ing\_Docs\_Phase 2\General\02\2115-shl-soc-12.dgn



USER NAME = dlevin	DESIGNED -	REVISED -
PLOT SCALE = 24.0000' / ft.	DRAWN -	REVISED -
PLOT DATE = 3/22/2022	CHECKED -	REVISED -
	DATE = 03/17/2022	REVISED -

**STATE OF ILLINOIS**  
**DEPARTMENT OF TRANSPORTATION**

**SUMMARY OF QUANTITIES**

SCALE: SHEET OF SHEETS STA. TO STA.

F.A./P.RTE.	SECTION	COUNTY	TOTAL SHEETS	SHEET NO.
*	2018-075-R	WILL	1510	20
			CONTRACT NO. 62H15	
* FAI 55, FAP 338		ILLINOIS FED. AID PROJECT		

CODE NO.	ITEM DESCRIPTION	UNIT	TOTAL QUANTITY	ROADWAY URBAN			ROADWAY LIGHTING		LED STREET SIGNS SHARED-USE PATH	OVERHEAD SIGNING	OVERHEAD SIGNING	RETAINING WALLS 099-1002 099-1003 099-1004	BRIDGE SN 099-4642	BRIDGE SN 099-4666	EMERGENCY VEHICLE PREEMPTION		TRAFFIC SIGNALS			SHARED-USE PATH	
				URBAN			IL 59	INTERCHANGE	SEIL ROAD	GATEWAY BOULEVARD	RAMP C				SEIL ROAD	DDI	INTERCONNECT		SEIL ROAD		DDI
				0004	0004	0004	0021	0021	0021	0004	0004				0044	0010	0010	0021	0021		0021
				100% STATE	80% FED 20% STATE	100% JOLIET	100% SHOREWOOD	100% STATE	100% SHOREWOOD	100% JOLIET	50% STATE 50% JOLIET	100% STATE	100% STATE	100% SHOREWOOD	100% JOLIET	100% STATE	100% JOLIET	96.7% STATE 3.3% SHOREWOOD	50% STATE 50% JOLIET	100% STATE	
6022446	MANHOLES, TYPE A, 7'-DIAMETER, TYPE 1 FRAME, CLOSED LID	EACH	5	4		1															
6022449	MANHOLES, TYPE A, 7'-DIAMETER, TYPE 24 FRAME AND GRATE	EACH	1			1															
6022456	MANHOLES, TYPE A, 8'-DIAMETER, TYPE 24 FRAME AND GRATE	EACH	1			1															
6022458	MANHOLES, TYPE A, 8'-DIAMETER, TYPE 8 GRATE	EACH	1	1																	
6022459	MANHOLES, TYPE A, 8'-DIAMETER, TYPE 1 FRAME, CLOSED LID	EACH	2	1		1															
6022468	MANHOLES, TYPE A, 9'-DIAMETER, TYPE 8 GRATE	EACH	1	1																	
6022469	MANHOLES, TYPE A, 9'-DIAMETER, TYPE 1 FRAME, CLOSED LID	EACH	2	1		1															
6022476	MANHOLES, TYPE A, 9'-DIAMETER, TYPE 24 FRAME AND GRATE	EACH	1			1															
60236200	INLETS, TYPE A, TYPE 8 GRATE	EACH	4	4																	
60236825	INLETS, TYPE A, TYPE 11V FRAME AND GRATE	EACH	4	2		2															
60236900	INLETS, TYPE A, TYPE 12 FRAME AND GRATE	EACH	2	2																	
60237470	INLETS, TYPE A, TYPE 24 FRAME AND GRATE	EACH	48	30		18															
60240328	INLETS, TYPE B, TYPE 24 FRAME AND GRATE	EACH	2	2																	
60500040	REMOVING MANHOLES	EACH	14	14																	
60500050	REMOVING CATCH BASINS	EACH	24	24																	
60500060	REMOVING INLETS	EACH	27	27																	

MODEL: Default  
 FILE NAME: p:\benesch\p\benesch\p\benesch\p\10700\10740\001ing\_Docs\_Phase 3\General\02H15-sht-soq-13.dgn



USER NAME = dlevin	DESIGNED -	REVISED -
PLOT SCALE = 24.0000' / ft.	DRAWN -	REVISED -
PLOT DATE = 3/22/2022	CHECKED -	REVISED -
	DATE = 03/17/2022	REVISED -

**STATE OF ILLINOIS**  
**DEPARTMENT OF TRANSPORTATION**

SUMMARY OF QUANTITIES			
SCALE:	SHEET	OF	SHEETS
	STA.		TO STA.

F.A./P.RTE.	SECTION	COUNTY	TOTAL SHEETS	SHEET NO.
*	2018-075-R	WILL	1510	21
			CONTRACT NO. 62H15	
* FAI 55, FAP 338		ILLINOIS FED. AID PROJECT		

CODE NO.	ITEM DESCRIPTION	UNIT	TOTAL QUANTITY	ROADWAY URBAN			ROADWAY LIGHTING		LED STREET SIGNS SHARED-USE PATH	OVERHEAD SIGNING	OVERHEAD SIGNING	RETAINING WALLS 099-1002 099-1003 099-1004	BRIDGE SN 099-4642	BRIDGE SN 099-4666	EMERGENCY VEHICLE PREEMPTION		TRAFFIC SIGNALS			SHARED-USE PATH	
				0004	0004	0004	IL 59	INTERCHANGE	SEIL ROAD	GATEWAY BOULEVARD	RAMP C				SEIL ROAD	DDI	INTERCONNECT		SEIL ROAD		DDI
				100% STATE	80% FED 20% STATE	100% JOLIET	100% SHOREWOOD	100% STATE	100% SHOREWOOD	100% JOLIET	50% STATE 50% JOLIET				100% STATE	100% STATE	100% SHOREWOOD	100% JOLIET	100% STATE		100% JOLIET
60602800	CONCRETE GUTTER, TYPE B	FOOT	999	999																	
60603500	COMBINATION CONCRETE CURB AND GUTTER, TYPE B-6.06	FOOT	120	120																	
60603800	COMBINATION CONCRETE CURB AND GUTTER, TYPE B-6.12	FOOT	379	379																	
60605000	COMBINATION CONCRETE CURB AND GUTTER, TYPE B-6.24	FOOT	29,426		15,226	14,200															
60605500	COMBINATION CONCRETE CURB AND GUTTER, TYPE B-6.24 (VARIABLE WIDTH GUTTER FLAG)	FOOT	52	52																	
60607400	COMBINATION CONCRETE CURB AND GUTTER, TYPE B-9.24	FOOT	950	828		122															
60608562	COMBINATION CONCRETE CURB AND GUTTER, TYPE M-4.12	FOOT	1,628	1,628																	
60608582	COMBINATION CONCRETE CURB AND GUTTER, TYPE M-4.24	FOOT	590	590																	
60619600	CONCRETE MEDIAN, TYPE SB-6.12	SQ FT	1,075	1,075																	
60620000	CONCRETE MEDIAN, TYPE SB-6.24	SQ FT	1,725	816		909															
60905305	BOX CULVERTS TO BE CLEANED	FOOT	652	652																	
60920021	PIPE CULVERTS TO BE CLEANED 21"	FOOT	50	50																	
60920024	PIPE CULVERTS TO BE CLEANED 24"	FOOT	400	400																	
60920030	PIPE CULVERTS TO BE CLEANED 30"	FOOT	350	350																	
60920036	PIPE CULVERTS TO BE CLEANED 36"	FOOT	250	250																	
60920042	PIPE CULVERTS TO BE CLEANED 42"	FOOT	250	250																	

MODEL: D:\default\benesch\pwr-03\Documents\1072004\10740\_001.dwg Phase 1\General\0162H15-sht-soq-14.dgn  
 FILE NAME: pwr-benesch-pwr-03\Documents\1072004\10740\_001.dwg Phase 1\General\0162H15-sht-soq-14.dgn



USER NAME = dlevin	DESIGNED -	REVISED -
PLOT SCALE = 24.0000' / ft.	DRAWN -	REVISED -
PLOT DATE = 3/22/2022	CHECKED -	REVISED -
	DATE = 03/17/2022	REVISED -

**STATE OF ILLINOIS**  
**DEPARTMENT OF TRANSPORTATION**

**SUMMARY OF QUANTITIES**

SCALE: SHEET OF SHEETS STA. TO STA.

F.A./P.RTE.	SECTION	COUNTY	TOTAL SHEETS	SHEET NO.
*	2018-075-R	WILL	1510	22
			CONTRACT NO. 62H15	
* FAI 55, FAP 338		ILLINOIS FED. AID PROJECT		

CODE NO.	ITEM DESCRIPTION	UNIT	TOTAL QUANTITY	ROADWAY URBAN			ROADWAY LIGHTING		LED STREET SIGNS SHARED-USE PATH	OVERHEAD SIGNING	OVERHEAD SIGNING	RETAINING WALLS 099-1002 099-1003 099-1004	BRIDGE SN 099-4642	BRIDGE SN 099-4666	EMERGENCY VEHICLE PREEMPTION		TRAFFIC SIGNALS			SHARED-USE PATH	
				URBAN			IL 59	INTERCHANGE	SEIL ROAD	GATEWAY BOULEVARD	RAMP C				SEIL ROAD	DDI	INTERCONNECT		SEIL ROAD		DDI
				0004	0004	0004	0021	0021	0021	0004	0304				0044	0010	0010	0021	0021		0021
				100% STATE	80% FED 20% STATE	100% JOLIET	100% SHOREWOOD	100% STATE	100% SHOREWOOD	100% JOLIET	50% STATE 50% JOLIET	100% STATE	100% STATE	100% SHOREWOOD	100% JOLIET	100% STATE	100% JOLIET	96.7% STATE 3.3% SHOREWOOD	50% STATE 50% JOLIET	100% STATE	
60920048	PIPE CULVERTS TO BE CLEANED 48"	FOOT	250	250																	
61100500	EXPLORATION TRENCH 52" DEPTH	FOOT	2,104			2,104															
61133100	FIELD TILE JUNCTION VAULTS, 2' DIA.	EACH	5			5															
61133200	FIELD TILE JUNCTION VAULTS, 3' DIA.	EACH	3			3															
61139800	STORM SEWERS (SPECIAL), 4"	FOOT	253			253															
61140000	STORM SEWERS (SPECIAL), 8"	FOOT	18			18															
61140200	STORM SEWERS (SPECIAL), 12"	FOOT	513			513															
X 63000001	STEEL PLATE BEAM GUARDRAIL, TYPE A, 6 FOOT POSTS	FOOT	7,650.0	3,025.0		4,625.0															
X 63000007	STEEL PLATE BEAM GUARDRAIL, TYPE B, 6 FOOT POSTS	FOOT	2,800	2,800																	
X 63100045	TRAFFIC BARRIER TERMINAL, TYPE 2	EACH	9	6		3															
X 63100085	TRAFFIC BARRIER TERMINAL, TYPE 6	EACH	4	4																	
X 63100105	TRAFFIC BARRIER TERMINAL, TYPE 10	EACH	2	2																	
X 63100167	TRAFFIC BARRIER TERMINAL, TYPE 1 (SPECIAL) TANGENT	EACH	13	10		3															
63200310	GUARDRAIL REMOVAL	FOOT	6,120	6,120																	
63500105	DELINEATORS	EACH	100	100																	
63700180	CONCRETE BARRIER, SINGLE FACE, 44 INCH HEIGHT	FOOT	480	480																	

MODEL: Default  
 FILE NAME: p:\benesch-ar\benesch-ar\benesch-ar\Documents\10700510740\_001\Eng\_Docs\_Phase II\General\62H15-shs-soq-15.dgn



USER NAME = dlevin	DESIGNED -	REVISED -
PLOT SCALE = 24,0000 * / ft.	DRAWN -	REVISED -
PLOT DATE = 3/22/2022	CHECKED -	REVISED -
	DATE - 03/17/2022	REVISED -

**STATE OF ILLINOIS**  
**DEPARTMENT OF TRANSPORTATION**

SUMMARY OF QUANTITIES			
SCALE:	SHEET	OF	SHEETS
	STA.	TO	STA.

F.A./P RTE.	SECTION	COUNTY	TOTAL SHEETS	SHEET NO.
*	2018-075-R	WILL	1510	23
CONTRACT NO. 62H15				
* FAI 55, FAP 338 ILLINOIS FED. AID PROJECT				

CODE NO.	ITEM DESCRIPTION	UNIT	TOTAL QUANTITY	ROADWAY URBAN			ROADWAY LIGHTING		LED STREET SIGNS SHARED-USE PATH	OVERHEAD SIGNING	OVERHEAD SIGNING	RETAINING WALLS 099-1002 099-1003 099-1004	BRIDGE SN 099-4642	BRIDGE SN 099-4666	EMERGENCY VEHICLE PREEMPTION		TRAFFIC SIGNALS			SHARED-USE PATH	
				0004	0004	0004	IL 59	INTERCHANGE	SEIL ROAD	GATEWAY BOULEVARD	RAMP C	0044	0010	0010	SEIL ROAD	DDI	INTERCONNECT		SEIL ROAD	DDI	0028
				100% STATE	80% FED 20% STATE	100% JOLIET	100% SHOREWOOD	100% STATE	100% SHOREWOOD	100% JOLIET	50% STATE 50% JOLIET	100% STATE	100% STATE	100% STATE	100% SHOREWOOD	100% JOLIET	100% STATE	100% JOLIET	96.7% STATE 3.3% SHOREWOOD	50% STATE 50% JOLIET	100% STATE
63700805	CONCRETE BARRIER TRANSITION	FOOT	280	280																	
63700900	CONCRETE BARRIER BASE	FOOT	480	480																	
63800920	MODULAR GLARE SCREEN SYSTEM, TEMPORARY	FOOT	638	638																	
64200116	SHOULDER RUMBLE STRIPS, 16 INCH	FOOT	62,766	62,766																	
X 64300240	IMPACT ATTENUATORS (FULLY REDIRECTIVE, NARROW), TEST LEVEL 2	EACH	1	1																	
66400105	CHAIN LINK FENCE, 4'	FOOT	9,095	6,488	2,607																
66400705	CHAIN LINK GATES, 4' X 4' SINGLE	EACH	6	4	2																
66406000	CHAIN LINK GATES, 4' X 16' DOUBLE	EACH	2	1	1																
X 66900200	NON-SPECIAL WASTE DISPOSAL	CU YD	26,049.0	14,693.0	11,356.0																
X 66900530	SOIL DISPOSAL ANALYSIS	EACH	10	8	2																
X 66901001	REGULATED SUBSTANCES PRE-CONSTRUCTION PLAN	L SUM	1	.87	.13																
X 66901003	REGULATED SUBSTANCES FINAL CONSTRUCTION REPORT	L SUM	1	.87	.13																
X 66901006	REGULATED SUBSTANCES MONITORING	CAL DA	361	327	34																
67100100	MOBILIZATION	L SUM	1.0	0.7	0.3																
70107025	CHANGEABLE MESSAGE SIGN	CAL DA	1,800	1,800																	
X 70300100	SHORT TERM PAVEMENT MARKING	FOOT	100,000	100,000																	

MODEL: D:\default\benesch\p\1622115\1622115-16.dgn  
 FILE NAME: p\1622115\1622115-16.dwg  
 Phase: 1622115-16.dwg  
 User: dlewin



USER NAME = dlewin	DESIGNED -	REVISED -
PLOT SCALE = 24.0000' / ft.	DRAWN -	REVISED -
PLOT DATE = 3/22/2022	CHECKED -	REVISED -
	DATE = 03/17/2022	REVISED -

**STATE OF ILLINOIS  
 DEPARTMENT OF TRANSPORTATION**

**SUMMARY OF QUANTITIES**

SCALE: SHEET OF SHEETS STA. TO STA.

F.A./P.RTE.	SECTION	COUNTY	TOTAL SHEETS	SHEET NO.
*	2018-075-R	WILL	1510	24
			CONTRACT NO. 62H15	
* FAI 55, FAP 338			ILLINOIS FED. AID PROJECT	



CODE NO.	ITEM DESCRIPTION	UNIT	TOTAL QUANTITY	ROADWAY URBAN			ROADWAY LIGHTING		LED STREET SIGNS SHARED-USE PATH	OVERHEAD SIGNING	OVERHEAD SIGNING	RETAINING WALLS 099-1002 099-1003 099-1004	BRIDGE SN 099-4642	BRIDGE SN 099-4666	EMERGENCY VEHICLE PREEMPTION		TRAFFIC SIGNALS			SHARED-USE PATH	
				0004	0004	0004	IL 59	INTERCHANGE	SEIL ROAD	GATEWAY BOULEVARD	RAMP C				SEIL ROAD	DDI	INTERCONNECT		SEIL ROAD		DDI
				100% STATE	80% FED 20% STATE	100% JOLIET	100% SHOREWOOD	100% STATE	100% SHOREWOOD	100% JOLIET	50% STATE 50% JOLIET				100% STATE	100% STATE	100% STATE	100% JOLIET	96.7% STATE 3.3% SHOREWOOD		50% STATE 50% JOLIET
X 70300150	SHORT TERM PAVEMENT MARKING REMOVAL	SQ FT	290,745	290,745																	
X 70303100	TEMPORARY PAVEMENT MARKING LETTERS AND SYMBOLS - MODIFIED URETHANE	SQ FT	1,342	1,342																	
X 70303120	TEMPORARY PAVEMENT MARKING - LINE 4" - MODIFIED URETHANE	FOOT	93,628	93,628																	
X 70303125	TEMPORARY PAVEMENT MARKING - LINE 5" - MODIFIED URETHANE	FOOT	8,875	8,875																	
X 70303130	TEMPORARY PAVEMENT MARKING - LINE 6" - MODIFIED URETHANE	FOOT	3,448	3,448																	
X 70303140	TEMPORARY PAVEMENT MARKING - LINE 8" - MODIFIED URETHANE	FOOT	5,600	5,600																	
X 70303160	TEMPORARY PAVEMENT MARKING - LINE 12" - MODIFIED URETHANE	FOOT	535	535																	
X 70303210	TEMPORARY PAVEMENT MARKING - LINE 24" - MODIFIED URETHANE	FOOT	303	303																	
X 70306100	TEMPORARY PAVEMENT MARKING LETTERS AND SYMBOLS - TYPE III TAPE	SQ FT	1,716	1,716																	
X 70306120	TEMPORARY PAVEMENT MARKING - LINE 4" - TYPE III TAPE	FOOT	44,233	44,233																	
X 70306130	TEMPORARY PAVEMENT MARKING - LINE 6" - TYPE III TAPE	FOOT	4,354	4,354																	
X 70306160	TEMPORARY PAVEMENT MARKING - LINE 12" - TYPE III TAPE	FOOT	730	730																	
X 70306210	TEMPORARY PAVEMENT MARKING - LINE 24" - TYPE III TAPE	FOOT	366	366																	
X 70307100	TEMPORARY PAVEMENT MARKING LETTERS AND SYMBOLS - TYPE IV TAPE	SQ FT	1,801	1,801																	
X 70307120	TEMPORARY PAVEMENT MARKING - LINE 4" - TYPE IV TAPE	FOOT	183,251	183,251																	
X 70307125	TEMPORARY PAVEMENT MARKING - LINE 5" - TYPE IV TAPE	FOOT	26,400	26,400																	

MODEL: Default  
 FILE NAME: p:\benesch-ar\benesch-ar\benesch-ar\Documents\10700510740\_001\Eng\_Docs\_Phase II\General\162H15-shs-soq-17.dgn



USER NAME = dlevin	DESIGNED -	REVISED -
PLOT SCALE = 24,0000 * / ft.	DRAWN -	REVISED -
PLOT DATE = 3/22/2022	CHECKED -	REVISED -
	DATE - 03/17/2022	REVISED -

**STATE OF ILLINOIS  
 DEPARTMENT OF TRANSPORTATION**

SUMMARY OF QUANTITIES			
SCALE:	SHEET	OF	SHEETS

F.A./P RTE.	SECTION	COUNTY	TOTAL SHEETS	SHEET NO.
*	2018-075-R	WILL	1510	25
CONTRACT NO. 62H15				
* FAI 55, FAP 338 ILLINOIS FED. AID PROJECT				

CODE NO.	ITEM DESCRIPTION	UNIT	TOTAL QUANTITY	ROADWAY URBAN			ROADWAY LIGHTING		LED STREET SIGNS SHARED-USE PATH	OVERHEAD SIGNING	OVERHEAD SIGNING	RETAINING WALLS 099-1002 099-1003 099-1004	BRIDGE SN 099-4642	BRIDGE SN 099-4666	EMERGENCY VEHICLE PREEMPTION		TRAFFIC SIGNALS			SHARED-USE PATH	
				0004	0004	0004	IL 59	INTERCHANGE	SEIL ROAD	GATEWAY BOULEVARD	RAMP C	0044	0010	0010	SEIL ROAD	DDI	INTERCONNECT		SEIL ROAD	DDI	0028
				100% STATE	80% FED 20% STATE	100% JOLIET	100% SHOREWOOD	100% STATE	100% SHOREWOOD	100% JOLIET	50% STATE 50% JOLIET	100% STATE	100% STATE	100% STATE	100% SHOREWOOD	100% JOLIET	100% STATE	100% JOLIET	96.7% STATE 3.3% SHOREWOOD	50% STATE 50% JOLIET	100% STATE
X 70307130	TEMPORARY PAVEMENT MARKING - LINE 6" - TYPE IV TAPE	FOOT	4,544	4,544																	
X 70307140	TEMPORARY PAVEMENT MARKING - LINE 8" - TYPE IV TAPE	FOOT	45,100	45,100																	
X 70307160	TEMPORARY PAVEMENT MARKING - LINE 12" - TYPE IV TAPE	FOOT	2,005	2,005																	
X 70307210	TEMPORARY PAVEMENT MARKING - LINE 24" - TYPE IV TAPE	FOOT	671	671																	
70400100	TEMPORARY CONCRETE BARRIER	FOOT	17,088		17,088																
70400125	PINNING TEMPORARY CONCRETE BARRIER	EACH	1,850	1,850																	
70400200	RELOCATE TEMPORARY CONCRETE BARRIER	FOOT	18,450	18,450																	
70600260	IMPACT ATTENUATORS, TEMPORARY (FULLY REDIRECTIVE, NARROW), TEST LEVEL 3	EACH	25	25																	
70600332	IMPACT ATTENUATORS, RELOCATE (FULLY REDIRECTIVE, NARROW), TEST LEVEL 3	EACH	37	37																	
X 72000100	SIGN PANEL - TYPE 1	SQ FT	1,004	579		313												40	72		
X 72000200	SIGN PANEL - TYPE 2	SQ FT	506	319		91													96		
X 72000300	SIGN PANEL - TYPE 3	SQ FT	9,043	8,189		0			421	433											
X 72400100	REMOVE SIGN PANEL ASSEMBLY - TYPE A	EACH	11	9		2															
X 72400200	REMOVE SIGN PANEL ASSEMBLY - TYPE B	EACH	41	41																	
X 72400310	REMOVE SIGN PANEL - TYPE 1	SQ FT	96	83		13															
X 72400320	REMOVE SIGN PANEL - TYPE 2	SQ FT	179	179																	

MODEL: D:\default\benesch\pwr-93\Documents\107200\107200-10-140-001.dwg Phase 1\General\107200-10-140-001-18.dgn  
 FILE NAME: pwr-93\benesch\pwr-93\Documents\107200\107200-10-140-001.dwg Phase 1\General\107200-10-140-001-18.dgn



USER NAME = dlevin	DESIGNED -	REVISED -
PLOT SCALE = 24.0000' / ft.	DRAWN -	REVISED -
PLOT DATE = 3/22/2022	CHECKED -	REVISED -
	DATE = 03/17/2022	REVISED -

**STATE OF ILLINOIS  
DEPARTMENT OF TRANSPORTATION**

SUMMARY OF QUANTITIES				
SCALE:	SHEET	OF	SHEETS	STA. TO STA.

F.A./P.RTE.	SECTION	COUNTY	TOTAL SHEETS	SHEET NO.
*	2018-075-R	WILL	1510	26
			CONTRACT NO. 62H15	
* FAI 55, FAP 338		ILLINOIS FED. AID PROJECT		

CODE NO.	ITEM DESCRIPTION	UNIT	TOTAL QUANTITY	ROADWAY URBAN			ROADWAY LIGHTING		LED STREET SIGNS SHARED-USE PATH	OVERHEAD SIGNING	OVERHEAD SIGNING	RETAINING WALLS 099-1002 099-1003 099-1004	BRIDGE SN 099-4642	BRIDGE SN 099-4666	EMERGENCY VEHICLE PREEMPTION		TRAFFIC SIGNALS			SHARED-USE PATH	
				0004	0004	0004	IL 59	INTERCHANGE	SEIL ROAD	GATEWAY BOULEVARD	RAMP C				SEIL ROAD	DDI	INTERCONNECT		SEIL ROAD		DDI
				100% STATE	80% FED 20% STATE	100% JOLIET	100% SHOREWOOD	100% STATE	100% SHOREWOOD	100% JOLIET	50% STATE 50% JOLIET				100% STATE	100% STATE	100% SHOREWOOD	100% JOLIET	100% STATE		100% JOLIET
X 72400330	REMOVE SIGN PANEL - TYPE 3	SQ FT	3,542	3,542																	
X 72400500	RELOCATE SIGN PANEL ASSEMBLY - TYPE A	EACH	22	21	1																
X 72400600	RELOCATE SIGN PANEL ASSEMBLY - TYPE B	EACH	14	14																	
X 72400710	RELOCATE SIGN PANEL - TYPE 1	SQ FT	201	193	8																
X 72400720	RELOCATE SIGN PANEL - TYPE 2	SQ FT	160	160																	
X 72400730	RELOCATE SIGN PANEL - TYPE 3	SQ FT	565	565																	
X 72501000	TERMINAL MARKER - DIRECT APPLIED	EACH	13	10	3																
X 72700100	STRUCTURAL STEEL SIGN SUPPORT - BREAKAWAY	POUND	10,334	10,334																	
X 72800100	TELESCOPING STEEL SIGN SUPPORT	FOOT	1,886	1,268	618																
X 73000100	WOOD SIGN SUPPORT	FOOT	292	292																	
X 73300100	OVERHEAD SIGN STRUCTURE - SPAN, TYPE I-A (4'-0" X 4'-6")	FOOT	365	175					90	100											
X 73300200	OVERHEAD SIGN STRUCTURE - SPAN, TYPE II-A (4'-6" X 5'-3")	FOOT	420	420																	
X 73300300	OVERHEAD SIGN STRUCTURE - SPAN, TYPE III-A (5'-0" X 7'-0")	FOOT	365	365																	
X 73302210	OVERHEAD SIGN STRUCTURE - CANTILEVER, TYPE III-C-A (36" X 7'-0")	FOOT	75	75																	
73400100	CONCRETE FOUNDATIONS	CU YD	21.0	21.0																	
73400200	DRILLED SHAFT CONCRETE FOUNDATIONS	CU YD	343.2	301.7					20.7	20.8											

MODEL: D:\default\benesch\pwr\benesch\pwr\3D\Documents\107200\107200\107200.dwg, Phase 1\General\107200\107200.dwg  
 FILE NAME: pwr\benesch\pwr\benesch\pwr\3D\Documents\107200\107200\107200.dwg, Phase 1\General\107200\107200.dwg



USER NAME = dlevin  
 DESIGNED -  
 DRAWN -  
 CHECKED -  
 DATE = 03/17/2022  
 PLOT SCALE = 24.0000' / ft.  
 PLOT DATE = 3/22/2022

**STATE OF ILLINOIS  
 DEPARTMENT OF TRANSPORTATION**

**SUMMARY OF QUANTITIES**  
 SCALE: SHEET OF SHEETS STA. TO STA.

F.A./P.RTE.	SECTION	COUNTY	TOTAL SHEETS	SHEET NO.
*	2018-075-R	WILL	1510	27
			CONTRACT NO. 62H15	
* FAI 55, FAP 338		ILLINOIS FED. AID PROJECT		

CODE NO.	ITEM DESCRIPTION	UNIT	TOTAL QUANTITY	ROADWAY URBAN			ROADWAY LIGHTING		LED STREET SIGNS SHARED-USE PATH	OVERHEAD SIGNING	OVERHEAD SIGNING	RETAINING WALLS 099-1002 099-1003 099-1004	BRIDGE SN 099-4642	BRIDGE SN 099-4666	EMERGENCY VEHICLE PREEMPTION		TRAFFIC SIGNALS			SHARED-USE PATH	
				URBAN			IL 59	INTERCHANGE	SEIL ROAD	GATEWAY BOULEVARD	RAMP C				SEIL ROAD	DDI	INTERCONNECT		SEIL ROAD		DDI
				0004	0004	0004	0021	0021	0021	0004	0304				0044	0010	0010	0021	0021		0021
				100% STATE	80% FED 20% STATE	100% JOLIET	100% SHOREWOOD	100% STATE	100% SHOREWOOD	100% JOLIET	50% STATE 50% JOLIET	100% STATE	100% STATE	100% SHOREWOOD	100% JOLIET	100% STATE	100% JOLIET	96.7% STATE 3.3% SHOREWOOD	50% STATE 50% JOLIET	100% STATE	
X 73500005	REMOVE OVERHEAD SIGN STRUCTURE - SPAN	EACH	2	2																	
X 73500010	REMOVE OVERHEAD SIGN STRUCTURE - CANTILEVER	EACH	4	4																	
X 73500300	REMOVE AND RELOCATE GROUND MOUNTED SIGN SUPPORT	EACH	38	37		1															
X 73700100	REMOVE GROUND MOUNTED SIGN SUPPORT	EACH	38	38																	
73700200	REMOVE CONCRETE FOUNDATION - GROUND MOUNT	EACH	18	18																	
73700300	REMOVE CONCRETE FOUNDATION - OVERHEAD	EACH	6	6																	
X 78000100	THERMOPLASTIC PAVEMENT MARKING - LETTERS AND SYMBOLS	SQ FT	1,284	1,211		73															
X 78000200	THERMOPLASTIC PAVEMENT MARKING - LINE 4"	FOOT	99,901	78,812		21,089															
X 78000400	THERMOPLASTIC PAVEMENT MARKING - LINE 6"	FOOT	1,907	1,155		752															
X 78000500	THERMOPLASTIC PAVEMENT MARKING - LINE 8"	FOOT	35,065	35,065																	
X 78000600	THERMOPLASTIC PAVEMENT MARKING - LINE 12"	FOOT	5,879	5,303		576															
X 78000650	THERMOPLASTIC PAVEMENT MARKING - LINE 24"	FOOT	80	26		54															
X 78004620	PREFORMED PLASTIC PAVEMENT MARKING, TYPE D - LINE 4"	FOOT	484	438		46															
X 78004625	PREFORMED PLASTIC PAVEMENT MARKING, TYPE D - LINE 5"	FOOT	18,140	18,140																	
X 78004630	PREFORMED PLASTIC PAVEMENT MARKING, TYPE D - LINE 6"	FOOT	824	716		108															
X 78004640	PREFORMED PLASTIC PAVEMENT MARKING, TYPE D - LINE 8"	FOOT	1,641	1,641																	

MODEL: Default  
 FILE: M:\E:\pub\benesch-aw\benesch-aw\benesch-aw\1\Documents\1\0700510740\_001\Eng\_Docs\_Phase II\General\162H15-shi-soq-20.dgn



USER NAME = dlevin	DESIGNED -	REVISED -
PLOT SCALE = 24,0000 * / ft.	DRAWN -	REVISED -
PLOT DATE = 3/22/2022	CHECKED -	REVISED -
	DATE - 03/17/2022	REVISED -

**STATE OF ILLINOIS  
DEPARTMENT OF TRANSPORTATION**

**SUMMARY OF QUANTITIES**

SCALE: SHEET OF SHEETS STA. TO STA.

F.A./P RTE.	SECTION	COUNTY	TOTAL SHEETS	SHEET NO.
	2018-075-R	WILL	1510	28
CONTRACT NO. 62H15				
* FAI 55, FAP 338 ILLINOIS FED. AID PROJECT				

CODE NO.	ITEM DESCRIPTION	UNIT	TOTAL QUANTITY	ROADWAY URBAN			ROADWAY LIGHTING		LED STREET SIGNS SHARED-USE PATH	OVERHEAD SIGNING	OVERHEAD SIGNING	RETAINING WALLS 099-1002 099-1003 099-1004	BRIDGE SN 099-4642	BRIDGE SN 099-4666	EMERGENCY VEHICLE PREEMPTION		TRAFFIC SIGNALS			SHARED-USE PATH	
				0004	0004	0004	IL 59	INTERCHANGE	SEIL ROAD	GATEWAY BOULEVARD	RAMP C				SEIL ROAD	DDI	INTERCONNECT		SEIL ROAD		DDI
				100% STATE	80% FED 20% STATE	100% JOLIET	100% SHOREWOOD	100% STATE	100% SHOREWOOD	100% JOLIET	50% STATE 50% JOLIET				100% STATE	100% STATE	100% STATE	100% JOLIET	96.7% STATE 3.3% SHOREWOOD		50% STATE 50% JOLIET
X 78009000	MODIFIED URETHANE PAVEMENT MARKING - LETTERS AND SYMBOLS	SQ FT	2,570	1,734		836															
X 78009004	MODIFIED URETHANE PAVEMENT MARKING - LINE 4"	FOOT	22,173	14,532		7,641															
X 78009006	MODIFIED URETHANE PAVEMENT MARKING - LINE 6"	FOOT	5,147	4,026		1,121															
X 78009008	MODIFIED URETHANE PAVEMENT MARKING - LINE 8"	FOOT	2,605	789		1,816															
X 78009012	MODIFIED URETHANE PAVEMENT MARKING - LINE 12"	FOOT	2,769	1,407		1,362															
X 78009024	MODIFIED URETHANE PAVEMENT MARKING - LINE 24"	FOOT	573	329		244															
X 78011025	GROOVING FOR RECESSED PAVEMENT MARKING 5"	FOOT	484	438		46															
X 78011030	GROOVING FOR RECESSED PAVEMENT MARKING 6"	FOOT	18,140	18,140																	
X 78011035	GROOVING FOR RECESSED PAVEMENT MARKING 7"	FOOT	824	716		108															
X 78011045	GROOVING FOR RECESSED PAVEMENT MARKING 9"	FOOT	3,941	3,221		720															
X 78100100	RAISED REFLECTIVE PAVEMENT MARKER	EACH	771	442		329															
X 78100300	REPLACEMENT REFLECTOR	EACH	2,298	2,298																	
X 78200005	GUARDRAIL REFLECTORS, TYPE A	EACH	78	61		17															
X 78200020	CURB REFLECTORS	EACH	235	127		108															
78300201	PAVEMENT MARKING REMOVAL - GRINDING	SQ FT	9,100	9,100																	
78300202	PAVEMENT MARKING REMOVAL - WATER BLASTING	SQ FT	84,083	84,083																	

MODEL: Default  
 FILE NAME: pub\benesch-pub\benesch-epw-01\Documents\10700510740\_001\Eng\_Docs\_Phase II\General\162H115-shs-soq-21.dgn



USER NAME = dlevin  
 DESIGNED -  
 DRAWN -  
 CHECKED -  
 DATE - 03/17/2022  
 PLOT SCALE = 24,0000 \* / ft.  
 PLOT DATE = 3/22/2022  
 REVISIONS:  
 REVISIONS -  
 REVISIONS -  
 REVISIONS -  
 REVISIONS -

**STATE OF ILLINOIS  
DEPARTMENT OF TRANSPORTATION**

**SUMMARY OF QUANTITIES**

SCALE: SHEET OF SHEETS STA. TO STA.

F.A./P RTE.	SECTION	COUNTY	TOTAL SHEETS	SHEET NO.
*	2018-075-R	WILL	1510	29
CONTRACT NO. 62H15				
* FAI 55, FAP 338 ILLINOIS FED. AID PROJECT				

CODE NO.	ITEM DESCRIPTION	UNIT	TOTAL QUANTITY	ROADWAY URBAN			ROADWAY LIGHTING		LED STREET SIGNS SHARED-USE PATH	OVERHEAD SIGNING	OVERHEAD SIGNING	RETAINING WALLS 099-1002 099-1003 099-1004	BRIDGE SN 099-4642	BRIDGE SN 099-4666	EMERGENCY VEHICLE PREEMPTION		TRAFFIC SIGNALS			SHARED-USE PATH	
				0004	0004	0004	IL 59	INTERCHANGE	SEIL ROAD	GATEWAY BOULEVARD	RAMP C				SEIL ROAD	DDI	INTERCONNECT		SEIL ROAD		DDI
				100% STATE	80% FED 20% STATE	100% JOLIET	100% SHOREWOOD	100% STATE	100% SHOREWOOD	100% JOLIET	50% STATE 50% JOLIET				100% STATE	100% STATE	100% SHOREWOOD	100% JOLIET	100% STATE		100% JOLIET
X 80400100	ELECTRIC SERVICE INSTALLATION	EACH	1						1												
X 80400200	ELECTRIC UTILITY SERVICE CONNECTION	L SUM	1						1												
X 81028200	UNDERGROUND CONDUIT, GALVANIZED STEEL, 2" DIA.	FOOT	5,876	881												743	788	791	2,673		
X 81028220	UNDERGROUND CONDUIT, GALVANIZED STEEL, 3" DIA.	FOOT	957					200										122	635		
X 81028240	UNDERGROUND CONDUIT, GALVANIZED STEEL, 4" DIA.	FOOT	7,170	398				1,695										657	4,420		
X 81028750	UNDERGROUND CONDUIT, COILABLE NONMETALLIC CONDUIT, 2" DIA.	FOOT	1,000	1,000																	
X 81100462	CONDUIT ATTACHED TO STRUCTURE, 3" DIA., STAINLESS STEEL	FOOT	20					20													
X 81200230	CONDUIT EMBEDDED IN STRUCTURE, 2" DIA., PVC	FOOT	90					90													
X 81300560	JUNCTION BOX, STAINLESS STEEL, ATTACHED TO STRUCTURE, 12" X 18" X 6"	EACH	2					2													
X 81400100	HANDHOLE	EACH	24														1	4	19		
X 81400200	HEAVY-DUTY HANDHOLE	EACH	4	2														1	1		
X 81400300	DOUBLE HANDHOLE	EACH	10															2	8		
X 81603081	UNIT DUCT, 600V, 3-1C NO.2, 1/C NO.4 GROUND, (XLP-TYPE USE), 1 1/2" DIA. POLYETHYLENE	FOOT	11,360				400	10,960													
X 81603090	UNIT DUCT, 600V, 3-1C NO.4, 1/C NO.6 GROUND, (XLP-TYPE USE), 1 1/4" DIA. POLYETHYLENE	FOOT	7,710					7,710													
X 81702140	ELECTRIC CABLE IN CONDUIT, 600V (XLP-TYPE USE) 1/C NO. 4	FOOT	390					390													

MODEL: D:\default\benesch\pwr\benesch\pwr\3Documents\107090\10740\_001ing\_Docs\_Phase 2\General\0162H15-sht-soq-22.dgn  
 FILE NAME: pwr\benesch\pwr\benesch\pwr\3Documents\107090\10740\_001ing\_Docs\_Phase 2\General\0162H15-sht-soq-22.dgn



USER NAME = dlevin	DESIGNED -	REVISED -
PLOT SCALE = 24.0000' / ft.	DRAWN -	REVISED -
PLOT DATE = 3/22/2022	CHECKED -	REVISED -
	DATE = 03/17/2022	REVISED -

**STATE OF ILLINOIS**  
**DEPARTMENT OF TRANSPORTATION**

**SUMMARY OF QUANTITIES**

SCALE: SHEET OF SHEETS STA. TO STA.

F.A./P.RTE.	SECTION	COUNTY	TOTAL SHEETS	SHEET NO.
*	2018-075-R	WILL	1510	30
			CONTRACT NO. 62H15	
* FAI 55, FAP 338 ILLINOIS FED. AID PROJECT				

CODE NO.	ITEM DESCRIPTION	UNIT	TOTAL QUANTITY	ROADWAY URBAN			ROADWAY LIGHTING		LED STREET SIGNS SHARED-USE PATH	OVERHEAD SIGNING	OVERHEAD SIGNING	RETAINING WALLS 099-1002 099-1003 099-1004	BRIDGE SN 099-4642	BRIDGE SN 099-4666	EMERGENCY VEHICLE PREEMPTION		TRAFFIC SIGNALS			SHARED-USE PATH	
				0004	0004	0004	IL 59	INTERCHANGE	SEIL ROAD	GATEWAY BOULEVARD	RAMP C				SEIL ROAD	DDI	INTERCONNECT		SEIL ROAD		DDI
				100% STATE	80% FED 20% STATE	100% JOLIET	100% SHOREWOOD	100% STATE	100% SHOREWOOD	100% JOLIET	50% STATE 50% JOLIET				100% STATE	100% STATE	100% SHOREWOOD	100% JOLIET	100% STATE		100% JOLIET
X 81702150	ELECTRIC CABLE IN CONDUIT, 600V (XLP-TYPE USE) 1/C NO. 2	FOOT	1,170																		
X 81702220	ELECTRIC CABLE IN CONDUIT, 600V (XLP-TYPE USE) 1/C 350MCM	FOOT	690																		
X 81800300	AERIAL CABLE, 3-1/C NO. 2 WITH MESSENGER WIRE	FOOT	10,530																		
X 82110008	LUMINAIRE, LED, ROADWAY, OUTPUT DESIGNATION H	EACH	173																		
X 82110026	LUMINAIRE, LED, UNDERPASS, SUSPENDED, OUTPUT DESIGNATION D	EACH	4																		
X 82500420	LIGHTING CONTROLLER, BASE MOUNTED, 480VOLT, 200AMP (DUAL)	EACH	1																		
X 83050730	LIGHT POLE, ALUMINUM, 47.5 FT. M.H., 8 FT. DAVIT ARM	EACH	2																		
X 83050825	LIGHT POLE, ALUMINUM, 47.5 FT. M.H., 15 FT. DAVIT ARM	EACH	97																		
X 83057355	LIGHT POLE, WOOD, 60 FOOT, CLASS 4, WITH 15FT MAST ARM	EACH	39																		
X 83600200	LIGHT POLE FOUNDATION, 24" DIAMETER	FOOT	1,260																		
X 83600300	LIGHT POLE FOUNDATION, 30" DIAMETER	FOOT	18				18														
X 83800205	BREAKAWAY DEVICE, TRANSFORMER BASE, 15 INCH BOLT CIRCLE	EACH	140																		
X 84100110	REMOVAL OF TEMPORARY LIGHTING UNIT	EACH	63																		
X																					
X 84200804	REMOVAL OF POLE FOUNDATION	EACH	45				2	43													
X 84400105	RELOCATE EXISTING LIGHTING UNIT	EACH	45				2	43													

MODEL: D:\default\benesch\pwr\benesch\pwr\3Documents\10700\10740\_001.dwg Phase 1\General\1072115-shl-soq-23.dgn  
 FILE NAME: pwr\benesch\pwr\benesch\pwr\3Documents\10700\10740\_001.dwg Phase 1\General\1072115-shl-soq-23.dgn



USER NAME = dlevin	DESIGNED -	REVISED -
PLOT SCALE = 24.0000' / ft.	DRAWN -	REVISED -
PLOT DATE = 3/22/2022	CHECKED -	REVISED -
	DATE = 03/17/2022	REVISED -

**STATE OF ILLINOIS  
DEPARTMENT OF TRANSPORTATION**

**SUMMARY OF QUANTITIES**

SCALE: SHEET OF SHEETS STA. TO STA.

F.A./P.RTE.	SECTION	COUNTY	TOTAL SHEETS	SHEET NO.
*	2018-075-R	WILL	1510	31
			CONTRACT NO. 62H15	
* FAI 55, FAP 338		ILLINOIS FED. AID PROJECT		

CODE NO.	ITEM DESCRIPTION	UNIT	TOTAL QUANTITY	ROADWAY URBAN			ROADWAY LIGHTING		LED STREET SIGNS SHARED-USE PATH	OVERHEAD SIGNING	OVERHEAD SIGNING	RETAINING WALLS 099-1002 099-1003 099-1004	BRIDGE SN 099-4642	BRIDGE SN 099-4666	EMERGENCY VEHICLE PREEMPTION		TRAFFIC SIGNALS			SHARED-USE PATH		
				URBAN			IL 59	INTERCHANGE	SEIL ROAD	GATEWAY BOULEVARD	RAMP C				SEIL ROAD	DDI	INTERCONNECT		SEIL ROAD		DDI	
				0004	0004	0004	0021	0021	0021	0004	0304				0044	0010	0010	0021	0021		0021	0021
				100% STATE	80% FED 20% STATE	100% JOLIET	100% SHOREWOOD	100% STATE	100% SHOREWOOD	100% JOLIET	50% STATE 50% JOLIET	100% STATE	100% STATE	100% SHOREWOOD	100% JOLIET	100% STATE	100% JOLIET	96.7% STATE 3.3% SHOREWOOD	50% STATE 50% JOLIET	100% STATE		
X 84500110	REMOVAL OF LIGHTING CONTROLLER	EACH	1							1												
X 84500120	REMOVAL OF ELECTRIC SERVICE INSTALLATION	EACH	1							1												
X 84500130	REMOVAL OF LIGHTING CONTROLLER FOUNDATION	EACH	1							1												
X 85000200	MAINTENANCE OF EXISTING TRAFFIC SIGNAL INSTALLATION	EACH	1															1				
X 85100500	PAINT NEW TRAFFIC SIGNAL POST	EACH	5								5											
X 85100800	PAINT NEW COMBINATION MAST ARM AND POLE, UNDER 40 FOOT	EACH	1								1											
X 85100901	PAINT NEW COMBINATION MAST ARM AND POLE, 40 FOOT AND OVER	EACH	2								2											
X 86400100	TRANSCEIVER - FIBER OPTIC	EACH	3															3				
X 87300925	ELECTRIC CABLE IN CONDUIT, TRACER, NO. 14 1C	FOOT	6,740															6,740				
X 87301215	ELECTRIC CABLE IN CONDUIT, SIGNAL NO. 14 2C	FOOT	6,150																810	5,340		
X 87301225	ELECTRIC CABLE IN CONDUIT, SIGNAL NO. 14 3C	FOOT	11,110												610	4,540			690	5,270		
X 87301245	ELECTRIC CABLE IN CONDUIT, SIGNAL NO. 14 5C	FOOT	32,220																3,440	28,780		
X 87301255	ELECTRIC CABLE IN CONDUIT, SIGNAL NO. 14 7C	FOOT	560																560			
X 87301305	ELECTRIC CABLE IN CONDUIT, LEAD-IN, NO. 14 1 PAIR	FOOT	12,480																2,460	10,020		
X 87301790	ELECTRIC CABLE IN CONDUIT, SERVICE, NO. 2 2 C	FOOT	1,490																		1,490	
X 87301805	ELECTRIC CABLE IN CONDUIT, SERVICE, NO. 6 2 C	FOOT	200																200			

MODEL: Default  
 FILE: M:\E:\p\benesch-ar\benesch-ar\benesch-ar\Documents\10700510740\_001\Eng\_Docs\_Phase II\General\162H15-shi-soq-24.dgn  
 D:\162H15-shi-soq-24.dgn  
 50107  
 2012/11/30



USER NAME = dlevin	DESIGNED -	REVISED -
PLOT SCALE = 24,0000 * / ft.	DRAWN -	REVISED -
PLOT DATE = 3/22/2022	CHECKED -	REVISED -
	DATE - 03/17/2022	REVISED -

**STATE OF ILLINOIS**  
**DEPARTMENT OF TRANSPORTATION**

SUMMARY OF QUANTITIES			
SCALE:	SHEET	OF	SHEETS
	STA.		TO STA.

F.A./P RTE.	SECTION	COUNTY	TOTAL SHEETS	SHEET NO.
*	2018-075-R	WILL	1510	32
CONTRACT NO. 62H15				
* FAI 55, FAP 338 ILLINOIS FED. AID PROJECT				



X = SPECIALTY ITEM				ROADWAY URBAN			ROADWAY LIGHTING		LED STREET SIGNS SHARED-USE PATH	OVERHEAD SIGNING	OVERHEAD SIGNING	RETAINING WALLS 099-1002 099-1003 099-1004	BRIDGE SN 099-4642	BRIDGE SN 099-4666	EMERGENCY VEHICLE PREEMPTION		TRAFFIC SIGNALS			SHARED-USE PATH	
CODE NO.	ITEM DESCRIPTION	UNIT	TOTAL QUANTITY	URBAN			IL 59	INTERCHANGE	SEIL ROAD	GATEWAY BOULEVARD	RAMP C	0044	0010	0010	SEIL ROAD	DDI	INTERCONNECT		SEIL ROAD	DDI	0028
				100% STATE	80% FED 20% STATE	100% JOLIET	100% SHOREWOOD	100% STATE	100% SHOREWOOD	100% JOLIET	50% STATE 50% JOLIET				100% STATE	100% STATE	100% STATE	100% JOLIET	100% STATE	100% JOLIET	
X 87301900	ELECTRIC CABLE IN CONDUIT, EQUIPMENT GROUNDING CONDUCTOR, NO. 6 1C	FOOT	10,100																1,170	8,930	
X 87502500	TRAFFIC SIGNAL POST, GALVANIZED STEEL 16 FT.	EACH	16																3	13	
X 87502520	TRAFFIC SIGNAL POST, GALVANIZED STEEL 18 FT.	EACH	6																1	5	
X 87700170	STEEL MAST ARM ASSEMBLY AND POLE, 26 FT.	EACH	1																		1
X 87702860	STEEL COMBINATION MAST ARM ASSEMBLY AND POLE 26 FT.	EACH	4																		4
X 87702870	STEEL COMBINATION MAST ARM ASSEMBLY AND POLE 28 FT.	EACH	1																		1
X 87702900	STEEL COMBINATION MAST ARM ASSEMBLY AND POLE 34 FT.	EACH	1																		1
X 87702920	STEEL COMBINATION MAST ARM ASSEMBLY AND POLE 38 FT.	EACH	2																1	1	
X 87702950	STEEL COMBINATION MAST ARM ASSEMBLY AND POLE 44 FT.	EACH	1																1		
X 87702980	STEEL COMBINATION MAST ARM ASSEMBLY AND POLE 50 FT.	EACH	2																1	1	
X 87800100	CONCRETE FOUNDATION, TYPE A	FOOT	100																20	80	
X 87800150	CONCRETE FOUNDATION, TYPE C	FOOT	12																4	8	
X 87800400	CONCRETE FOUNDATION, TYPE E 30-INCH DIAMETER	FOOT	10																		10
X 87800415	CONCRETE FOUNDATION, TYPE E 36-INCH DIAMETER	FOOT	131																39	92	
X 87900200	DRILL EXISTING HANDHOLE	EACH	1														1				
X 88030020	SIGNAL HEAD, LED, 1-FACE, 3-SECTION, MAST-ARM MOUNTED	EACH	27																8	19	

MODEL: Default  
 FILE: \\bmesch-pw-bentley.com\benesch\paw\01\Documents\10700510740\_001\Eng\_Docx\_Phase 1\General\162H15-shs-soq-25.dgn  
 D:\162H15-shs-soq-25.dgn  
 50 107  
 2012/11/30



USER NAME = dlevin	DESIGNED -	REVISED -
PLOT SCALE = 24,0000 * / ft.	DRAWN -	REVISED -
PLOT DATE = 3/22/2022	CHECKED -	REVISED -
	DATE = 03/17/2022	REVISED -

**STATE OF ILLINOIS  
DEPARTMENT OF TRANSPORTATION**

**SUMMARY OF QUANTITIES**

SCALE: SHEET OF SHEETS STA. TO STA.

F.A./P.RTE.	SECTION	COUNTY	TOTAL SHEETS	SHEET NO.
	2018-075-R	WILL	1510	33
CONTRACT NO. 62H15				
* FAI 55, FAP 338 ILLINOIS FED. AID PROJECT				

CODE NO.	ITEM DESCRIPTION	UNIT	TOTAL QUANTITY	ROADWAY URBAN			ROADWAY LIGHTING		LED STREET SIGNS SHARED-USE PATH	OVERHEAD SIGNING	OVERHEAD SIGNING	RETAINING WALLS 099-1002 099-1003 099-1004	BRIDGE SN 099-4642	BRIDGE SN 099-4666	EMERGENCY VEHICLE PREEMPTION		TRAFFIC SIGNALS			SHARED-USE PATH	
				URBAN			IL 59	INTERCHANGE	SEIL ROAD	GATEWAY BOULEVARD	RAMP C				SEIL ROAD	DDI	INTERCONNECT		SEIL ROAD		DDI
				0004	0004	0004	0021	0021	0021	0004	0304				0044	0010	0010	0021	0021		0021
				100% STATE	80% FED 20% STATE	100% JOLIET	100% SHOREWOOD	100% STATE	100% SHOREWOOD	100% JOLIET	50% STATE 50% JOLIET	100% STATE	100% STATE	100% SHOREWOOD	100% JOLIET	100% STATE	100% JOLIET	96.7% STATE 3.3% SHOREWOOD	50% STATE 50% JOLIET	100% STATE	
X 88030050	SIGNAL HEAD, LED, 1-FACE, 3-SECTION, BRACKET MOUNTED	EACH	29																6	23	
X 88030100	SIGNAL HEAD, LED, 1-FACE, 5-SECTION, BRACKET MOUNTED	EACH	1																1		
X 88030110	SIGNAL HEAD, LED, 1-FACE, 5-SECTION, MAST-ARM MOUNTED	EACH	2																2		
X 88102717	PEDESTRIAN SIGNAL HEAD, LED, 1-FACE, BRACKET MOUNTED WITH COUNTDOWN TIMER	EACH	10																2	8	
X 88200410	TRAFFIC SIGNAL BACKPLATE, LOUVERED, FORMED PLASTIC	EACH	29																10	19	
X 88500100	INDUCTIVE LOOP DETECTOR	EACH	31																7	24	
X 88600700	PREFORMED DETECTOR LOOP	FOOT	1,309																319	990	
X 88700200	LIGHT DETECTOR	EACH	9												3	6					
X 88700300	LIGHT DETECTOR AMPLIFIER	EACH	3												1	2					
X 89000100	TEMPORARY TRAFFIC SIGNAL INSTALLATION	EACH	1																1		
X 89500300	RELOCATE EXISTING ILLUMINATED SIGN	EACH	3						3												
X 89502300	REMOVE ELECTRIC CABLE FROM CONDUIT	FOOT	8,235	715													7,520				
X 89502375	REMOVE EXISTING TRAFFIC SIGNAL EQUIPMENT	EACH	1																1		
X 89502380	REMOVE EXISTING HANDHOLE	EACH	20	13															7		
X 89502382	REMOVE EXISTING DOUBLE HANDHOLE	EACH	1																1		
X 89502385	REMOVE EXISTING CONCRETE FOUNDATION	EACH	7																7		

MODEL: Default  
 FILE: M:\15-shi-sog-26\benesch\p1\Documents\10700510740\_001\Eng\_Docs\_Phase 1\General\162H15-shi-sog-26.dgn  
 D:\162H15-shi-sog-26.dgn  
 50107  
 2012/11/30



USER NAME = dlevin	DESIGNED -	REVISED -
PLOT SCALE = 24,0000 * / ft.	DRAWN -	REVISED -
PLOT DATE = 3/22/2022	CHECKED -	REVISED -
	DATE - 03/17/2022	REVISED -

**STATE OF ILLINOIS**  
**DEPARTMENT OF TRANSPORTATION**

SUMMARY OF QUANTITIES			
SCALE:	SHEET	OF	SHEETS
	STA.		TO STA.

F.A./P RTE.	SECTION	COUNTY	TOTAL SHEETS	SHEET NO.
*	2018-075-R	WILL	1510	34
CONTRACT NO. 62H15				
* FAI 55, FAP 338 ILLINOIS FED. AID PROJECT				

CODE NO.	ITEM DESCRIPTION	UNIT	TOTAL QUANTITY	ROADWAY URBAN			ROADWAY LIGHTING		LED STREET SIGNS SHARED-USE PATH	OVERHEAD SIGNING	OVERHEAD SIGNING	RETAINING WALLS 099-1002 099-1003 099-1004	BRIDGE SN 099-4642	BRIDGE SN 099-4666	EMERGENCY VEHICLE PREEMPTION		TRAFFIC SIGNALS			SHARED-USE PATH	
				0004	0004	0004	IL 59	INTERCHANGE	SEIL ROAD	GATEWAY BOULEVARD	RAMP C				SEIL ROAD	DDI	INTERCONNECT		SEIL ROAD		DDI
				100% STATE	80% FED 20% STATE	100% JOLIET	100% SHOREWOOD	100% STATE	100% SHOREWOOD	100% JOLIET	50% STATE 50% JOLIET				100% STATE	100% STATE	100% STATE	100% JOLIET	96.7% STATE 3.3% SHOREWOOD		50% STATE 50% JOLIET
X0301423	NOISE ABATEMENT WALL, GROUND MOUNTED	SQ FT	72,692		72,692																
X	X0320023	CLOSED CIRCUIT TELEVISION DOME CAMERA, HD	EACH	2	2																
	X0322141	REMOVE TEMPORARY WOOD POLE	EACH	10				10													
X	X0322920	COMMUNICATIONS CABINET AND EQUIPMENT	EACH	1																1	
	X0322924	RETAINING WALL REMOVAL	SQ FT	1,197								1,197									
	X0322936	REMOVE EXISTING FLARED END SECTION	EACH	36	30																
	X0322992	COARSE SAND PLACEMENT, 4"	SQ YD	370																	
X	X0323003	TEMPORARY ELECTRIC SERVICE INSTALLATION	EACH	1					1												
X	X0323914	FIBER OPTIC CABLE SPLICE - LATERAL	EACH	5	5																
X	X0323957	FIBER OPTIC CABLE SPLICE - MAINLINE	EACH	7	7																
X	X0324085	EMERGENCY VEHICLE PRIORITY SYSTEM LINE SENSOR CABLE, NO. 20 3/C	FOOT	5,355											755	4,600					
X	X0324599	ROD AND CLEAN EXISTING CONDUIT	FOOT	3,395														3,395			
	X0325410	PILE REMOVAL	FOOT	250	250																
X	X0326461	CLOSED CIRCUIT TELEVISION EQUIPMENT, FIBER OPTIC DISTRIBUTION	EACH	2	2																
	X0326806	WASHOUT BASIN	L SUM	1.0	0.5																
X	X0327117	ATMS SYSTEM INTEGRATION	L SUM	1	1																

MODEL: Default  
 FILE: \\benedsch-pw-bentley.com\benesch\pww\1\Documents\1\0700510740\_001\Eng\_Docs\_Phase II\General\162H115-shs-soq-27.dgn



USER NAME = dlevin  
 DESIGNED -  
 DRAWN -  
 PLOT SCALE = 24,0000 \* / ft.  
 CHECKED -  
 PLOT DATE = 3/22/2022  
 DATE = 03/17/2022  
 REVISED -  
 REVISED -  
 REVISED -  
 REVISED -

**STATE OF ILLINOIS  
 DEPARTMENT OF TRANSPORTATION**

**SUMMARY OF QUANTITIES**

SCALE: SHEET OF SHEETS STA. TO STA.

F.A./P RTE.	SECTION	COUNTY	TOTAL SHEETS	SHEET NO.
*	2018-075-R	WILL	1510	35
CONTRACT NO. 62H15				
* FAI 55, FAP 338 ILLINOIS FED. AID PROJECT				

CODE NO.	ITEM DESCRIPTION	UNIT	TOTAL QUANTITY	ROADWAY URBAN			ROADWAY LIGHTING		LED STREET SIGNS SHARED-USE PATH	OVERHEAD SIGNING	OVERHEAD SIGNING	RETAINING WALLS 099-1002 099-1003 099-1004	BRIDGE SN 099-4642	BRIDGE SN 099-4666	EMERGENCY VEHICLE PREEMPTION		TRAFFIC SIGNALS			SHARED-USE PATH	
				0004	0004	0004	IL 59	INTERCHANGE	SEIL ROAD	GATEWAY BOULEVARD	RAMP C				SEIL ROAD	DDI	INTERCONNECT		SEIL ROAD		DDI
				100% STATE	80% FED 20% STATE	100% JOLIET	100% SHOREWOOD	100% STATE	100% SHOREWOOD	100% JOLIET	50% STATE 50% JOLIET				100% STATE	100% STATE	100% SHOREWOOD	100% JOLIET	100% STATE		100% JOLIET
X	X0327214	REMOVAL OF TEMPORARY WOOD POLES AND FIBER OPTIC CABLE	L SUM	1	1																
X	X0327236	TEMPORARY WOOD POLE, 50 FT., CLASS 4	EACH	10				10													
	X0327374	REMOVAL OF TEMPORARY SOIL RETENTION SYSTEM	SQ FT	113							113										
X	X0327601	CLOSED CIRCUIT TELEVISION CAMERA STRUCTURE, FOUNDATION, 80 FT. MOUNTING HEIGHT	FOOT	34	34																
X	X0327602	CLOSED CIRCUIT TELEVISION CAMERA STRUCTURE, GALVANIZED STEEL, 80 FT. MOUNTING HEIGHT	EACH	2	2																
X	X0327609	REMOVE EXISTING TRAFFIC SURVEILLANCE EQUIPMENT	L SUM	1	1																
X	X0327616	MAINTAINING ITS DURING CONSTRUCTION	CAL MO	36	36																
	X0426200	DEWATERING	L SUM	1.0	0.5	0.5															
	X0900021	TEMPORARY BRIDGE	EACH	16	11	5															
	X0900064	MEMBRANE WATERPROOFING SYSTEM FOR BURIED STRUCTURES	SQ YD	394	394																
	X1200050	BOX CULVERT REMOVAL	FOOT	148	148																
X	X1400106	WIRELESS VEHICLE DETECTION SYSTEM	EACH	3	3																
X	X1400108	FULL-ACTUATED CONTROLLER AND TYPE SUPER R CABINET (SPECIAL)	EACH	1															1		
X	X1400150	SERVICE INSTALLATION, GROUND MOUNTED, METERED	EACH	3															1	2	
X	X1400201	RADAR VEHICLE DETECTION SYSTEM, SINGLE APPROACH, STOP BAR	EACH	1															1		
X	X1400282	POLYETHYLENE DUCT, 1 1/4" DIA	FOOT	15,735	15,735																

MODEL: Default  
 FILE: M:\E:\pub\benesch-ar\benesch-ar\benesch-ar\Documents\10700510740\_001\Eng\_Docs\_Phase II\General\162H115-shi-soq-28.dgn



USER NAME = dlevin	DESIGNED -	REVISED -
PLOT SCALE = 24,0000 * / ft.	DRAWN -	REVISED -
PLOT DATE = 3/22/2022	CHECKED -	REVISED -
	DATE - 03/17/2022	REVISED -

**STATE OF ILLINOIS  
DEPARTMENT OF TRANSPORTATION**

**SUMMARY OF QUANTITIES**

SCALE: SHEET OF SHEETS STA. TO STA.

F.A./P RTE.	SECTION	COUNTY	TOTAL SHEETS	SHEET NO.
*	2018-075-R	WILL	1510	36
CONTRACT NO. 62H15				
* FAI 55, FAP 338 ILLINOIS FED. AID PROJECT				

CODE NO.	ITEM DESCRIPTION	UNIT	TOTAL QUANTITY	ROADWAY URBAN			ROADWAY LIGHTING		LED STREET SIGNS SHARED-USE PATH	OVERHEAD SIGNING	OVERHEAD SIGNING	RETAINING WALLS 099-1002 099-1003 099-1004	BRIDGE SN 099-4642	BRIDGE SN 099-4666	EMERGENCY VEHICLE PREEMPTION		TRAFFIC SIGNALS			SHARED-USE PATH	
				0004	0004	0004	IL 59	INTERCHANGE	SEIL ROAD	GATEWAY BOULEVARD	RAMP C				SEIL ROAD	DDI	INTERCONNECT		SEIL ROAD		DDI
				100% STATE	80% FED 20% STATE	100% JOLIET	100% SHOREWOOD	100% STATE	100% SHOREWOOD	100% JOLIET	50% STATE 50% JOLIET				100% STATE	100% STATE	100% SHOREWOOD	100% JOLIET	100% STATE		100% JOLIET
X1400285	ELECTRIC CABLE IN CONDUIT (EPR-TYPE USE) 2C NO. 4 AND NO. 6 GROUND.	FOOT	1,551	1,551																	
X1400286	CABINET HOUSING EQUIPMENT, ESP 2, POLE MOUNTED	EACH	2	2																	
X1400337	WIRELESS IN PAVEMENT DETECTOR	EACH	6	6																	
X1400341	REMOVAL OF LUMINARIE, SALVAGE	EACH	64					64													
X1400367	PEDESTRIAN SIGNAL POST, 10 FT.	EACH	1																	1	
X1400386	RELOCATE EXISTING WIRELESS VEHICLE DETECTION SYSTEM	EACH	2	2																	
X1400424	ELECTRIC CABLE IN CONDUIT, STREET NAME SIGN, NO. 14 3C, TYPE SOOW	FOOT	680						680												
X2010350	TREE REMOVAL, ACRES (SPECIAL)	ACRE	10.00	10.00																	
X2511630	EROSION CONTROL BLANKET (SPECIAL)	SQ YD	12,584	12,584																	
X2700027	PREFORMED PLASTIC PAVEMENT MARKING, TYPE D - LINE 8", CONTRAST	FOOT	2,300	1,580	720																
X4021000	TEMPORARY ACCESS (PRIVATE ENTRANCE)	EACH	3	3																	
X4022000	TEMPORARY ACCESS (COMMERCIAL ENTRANCE)	EACH	5	5																	
X4024100	TEMPORARY ACCESS (WINTERIZE)	SQ YD	267	267																	
X4401198	HOT-MIX ASPHALT SURFACE REMOVAL, VARIABLE DEPTH	SQ YD	2,400	2,400																	
X4420828	CLASS D PATCHES, TYPE III, 12 INCH (SPECIAL)	SQ YD	881	869	12																
X5010520	REMOVE CONCRETE BOX CULVERT END SECTION	EACH	6	6																	

MODEL: Default  
 FILE: \\nafe\pub\benesch-pw\benesch-pw\01\Documents\10700510740\_001\Eng\_Docs\_Phase II\General\162H115-shi-soq-29.dgn



USER NAME = dlevin  
 DESIGNED -  
 DRAWN -  
 PLOT SCALE = 24,0000 \* / ft.  
 CHECKED -  
 PLOT DATE = 3/22/2022  
 DATE = 03/17/2022  
 REVISED -  
 REVISED -  
 REVISED -  
 REVISED -

**STATE OF ILLINOIS  
 DEPARTMENT OF TRANSPORTATION**

**SUMMARY OF QUANTITIES**

SCALE: SHEET OF SHEETS STA. TO STA.

F.A./P RTE.	SECTION	COUNTY	TOTAL SHEETS	SHEET NO.
*	2018-075-R	WILL	1510	37
CONTRACT NO. 62H15				
* FAI 55, FAP 338 ILLINOIS FED. AID PROJECT				

CODE NO.	ITEM DESCRIPTION	UNIT	TOTAL QUANTITY	ROADWAY URBAN			ROADWAY LIGHTING		LED STREET SIGNS SHARED-USE PATH	OVERHEAD SIGNING	OVERHEAD SIGNING	RETAINING WALLS 099-1002 099-1003 099-1004	BRIDGE SN 099-4642	BRIDGE SN 099-4666	EMERGENCY VEHICLE PREEMPTION		TRAFFIC SIGNALS			SHARED-USE PATH	
				0004	0004	0004	IL 59	INTERCHANGE	SEIL ROAD	GATEWAY BOULEVARD	RAMP C				SEIL ROAD	DDI	INTERCONNECT		SEIL ROAD		DDI
				100% STATE	80% FED 20% STATE	100% JOLIET	100% SHOREWOOD	100% STATE	100% SHOREWOOD	100% JOLIET	50% STATE 50% JOLIET				100% STATE	100% STATE	100% SHOREWOOD	100% JOLIET	100% STATE		100% JOLIET
X5030225	CONCRETE STRUCTURES (SPECIAL)	CU YD	990.1		990.1																
X5030305	CONCRETE WEARING SURFACE, 5"	SQ YD	372											372							
X5040100	PRECAST BRIDGE APPROACH SLAB	SQ FT	3,240											3,240							
X5510136	STORM SEWER REMOVAL, 36" (SPECIAL)	FOOT	817	817																	
X5537800	STORM SEWERS TO BE CLEANED 12"	FOOT	200	200																	
X5537900	STORM SEWERS TO BE CLEANED 15"	FOOT	200	200																	
X5538000	STORM SEWERS TO BE CLEANED 18"	FOOT	300	300																	
X5538200	STORM SEWERS TO BE CLEANED 24"	FOOT	200	200																	
X6020293	MANHOLES, TYPE A, 8"-DIAMETER, WITH 2 TYPE 1 FRAMES, CLOSED LID, RESTRICTOR PLATE	EACH	3	3																	
X6025801	MANHOLES TO BE ADJUSTED WITH NEW FRAME, CLOSED LID, BOLTED	EACH	2	2																	
X6061100	CONCRETE MEDIAN, TYPE SB (SPECIAL)	SQ FT	2,873	1,982	891																
X6061311	CONCRETE MEDIAN SURFACE, 5 INCH	SQ FT	3,365	3,365																	
X6061461	PAVED DITCH (VARIABLE)	SQ YD	2,385	2,385																	
X6062206	STAMPED COLORED PORTLAND CEMENT CONCRETE MEDIAN SURFACE 6 INCH	SQ FT	8,631	8,631																	
X6350120	DELINEATOR REMOVAL	EACH	40	40																	
X6370050	CONCRETE BARRIER WALL (SPECIAL)	FOOT	242	242																	

MODEL: Default  
 FILE NAME: p:\benesch-ar\benesch-ar\benesch-ar\Documents\10700510740\_001\Eng\_Docs\_Phase II\General\162H115-sh-sq-30.dgn



USER NAME = dlevin	DESIGNED -	REVISED -
PLOT SCALE = 24,0000 * / ft.	DRAWN -	REVISED -
PLOT DATE = 3/22/2022	CHECKED -	REVISED -
	DATE - 03/17/2022	REVISED -

**STATE OF ILLINOIS  
 DEPARTMENT OF TRANSPORTATION**

**SUMMARY OF QUANTITIES**

SCALE:	SHEET	OF	SHEETS	STA. Sta	TO STA. ToSta
--------	-------	----	--------	----------	---------------

F.A./P RTE.	SECTION	COUNTY	TOTAL SHEETS	SHEET NO.
*	2018-075-R	WILL	1510	38
CONTRACT NO. 62H15				
* FAI 55, FAP 338 ILLINOIS FED. AID PROJECT				

CODE NO.	ITEM DESCRIPTION	UNIT	TOTAL QUANTITY	ROADWAY URBAN			ROADWAY LIGHTING		LED STREET SIGNS SHARED-USE PATH	OVERHEAD SIGNING	OVERHEAD SIGNING	RETAINING WALLS 099-1002 099-1003 099-1004	BRIDGE SN 099-4642	BRIDGE SN 099-4666	EMERGENCY VEHICLE PREEMPTION		TRAFFIC SIGNALS			SHARED-USE PATH	
				URBAN			IL 59	INTERCHANGE	SEIL ROAD	GATEWAY BOULEVARD	RAMP C				SEIL ROAD	DDI	INTERCONNECT		SEIL ROAD		DDI
				0004	0004	0004	0021	0021	0021	0004	0004				0044	0010	0010	0021	0021		0021
				100% STATE	80% FED 20% STATE	100% JOLIET	100% SHOREWOOD	100% STATE	100% SHOREWOOD	100% JOLIET	50% STATE 50% JOLIET	100% STATE	100% STATE	100% SHOREWOOD	100% JOLIET	100% STATE	100% JOLIET	96.7% STATE 3.3% SHOREWOOD	50% STATE 50% JOLIET	100% STATE	
X6640210	TEMPORARY CHAIN LINK FENCE (PORTABLE)	FOOT	2,092	2,092																	
X6640300	CHAIN LINK FENCE REMOVAL	FOOT	10,362	10,362																	
X6640302	CHAIN LINK FENCE REMOVAL (SPECIAL)	FOOT	1,299	1,299																	
X6640525	CHAIN LINK FENCE, 4' ATTACHED TO STRUCTURE	FOOT	934								934										
X6650202	WOVEN WIRE FENCE REMOVAL	FOOT	4,962	4,962																	
X6700410	ENGINEER'S FIELD OFFICE, TYPE A (SPECIAL)	CAL MO	39	27		12															
X7010216	TRAFFIC CONTROL AND PROTECTION, (SPECIAL)	L SUM	1		1																
X7010240	TRAFFIC CONTROL SURVEILLANCE (SPECIAL)	CAL DA	900	900																	
X7011015	TRAFFIC CONTROL AND PROTECTION (EXPRESSWAYS)	L SUM	1		1																
X7013820	TRAFFIC CONTROL SURVEILLANCE, EXPRESSWAYS	CAL DA	900	900																	
X7830050	RAISED REFLECTIVE PAVEMENT MARKER, REFLECTOR REMOVAL	EACH	2,298	2,298																	
X X8100105	CONDUIT SPLICE	EACH	8																		8
X X8100863	INTERCEPT EXISTING CONDUIT	EACH	5	5																	
X X8211008	TEMPORARY LUMINAIRE, LED, ROADWAY, OUTPUT DEIGNATION H	EACH	39					39													
X X8250091	COMBINATION LIGHTING CONTROLLER	EACH	3					3													
X X8620200	UNINTERRUPTABLE POWER SUPPLY, SPECIAL	EACH	3																1	2	
X X8710024	FIBER OPTIC CABLE IN CONDUIT, NO. 62.5/125, MM12F SM24F	FOOT	6,740																	6,740	

MODEL: D:\default\benesch\pwr\benesch\pwr\3\Documents\10700\10740\00\ling\_Docs\_Phase 3\General\0162H15-shl-sop-31.dgn  
 FILE NAME: pwr\benesch\pwr\benesch\pwr\3\Documents\10700\10740\00\ling\_Docs\_Phase 3\General\0162H15-shl-sop-31.dgn



USER NAME = dlevin	DESIGNED -	REVISED -
	DRAWN -	REVISED -
PLOT SCALE = 24.0000' / ft.	CHECKED -	REVISED -
PLOT DATE = 3/22/2022	DATE = 03/17/2022	REVISED -

**STATE OF ILLINOIS**  
**DEPARTMENT OF TRANSPORTATION**

SUMMARY OF QUANTITIES			
SCALE:	SHEET	OF SHEETS	STA. TO STA.

F.A./P.RTE.	SECTION	COUNTY	TOTAL SHEETS	SHEET NO.
*	2018-075-R	WILL	1510	39
			CONTRACT NO. 62H15	
* FAI 55, FAP 338		ILLINOIS FED. AID PROJECT		

CODE NO.	ITEM DESCRIPTION	UNIT	TOTAL QUANTITY	ROADWAY URBAN			ROADWAY LIGHTING		LED STREET SIGNS SHARED-USE PATH	OVERHEAD SIGNING	OVERHEAD SIGNING	RETAINING WALLS 099-1002 099-1003 099-1004	BRIDGE SN 099-4642	BRIDGE SN 099-4666	EMERGENCY VEHICLE PREEMPTION		TRAFFIC SIGNALS			SHARED-USE PATH	
				0004	0004	0004	IL 59	INTERCHANGE	SEIL ROAD	GATEWAY BOULEVARD	RAMP C				SEIL ROAD	DDI	INTERCONNECT		SEIL ROAD		DDI
				100% STATE	80% FED 20% STATE	100% JOLIET	100% SHOREWOOD	100% STATE	100% SHOREWOOD	100% JOLIET	50% STATE 50% JOLIET				100% STATE	100% STATE	100% SHOREWOOD	100% JOLIET	100% STATE		100% JOLIET
X	X8710035	FIBER OPTIC CABLE 96 FIBERS, SINGLE MODE	FOOT	17,250	17,250																
X	X8710036	FIBER OPTIC CABLE 12 FIBERS, SINGLE MODE	FOOT	2,585	2,585																
X	X8710054	FIBER OPTIC TERMINATION PANEL, 12 F OR 24F	EACH	6	6																
X	X8760200	ACCESSIBLE PEDESTRIAN SIGNALS	EACH	11															3	8	
X	X8772115	TEMPORARY MAST ARM, ALUMINUM, 15FT	EACH	1				1													
X	X8780012	CONCRETE FOUNDATION, TYPE A 12-INCH DIAMETER	FOOT	4															4		
X	X8950090	RELOCATE EXISTING LIGHTING CONTROLLER	EACH	1				1													
X	X8950510	REMOVE FIBER OPTIC CABLE FROM CONDUIT	FOOT	13,060	13,060																
	Z0004530	HOT-MIX ASPHALT DRIVEWAY PAVEMENT, 8"	SQ YD	179	179																
	Z0004538	HOT-MIX ASPHALT DRIVEWAY PAVEMENT, 10"	SQ YD	2,133	2,013	120															
X	Z0005216	HOT-MIX ASPHALT STABILIZATION 6" AT STEEL PLATE BEAM GUARD RAIL	SQ YD	6,444	2,834	3,610															
X	Z0010614	CLEANING EXISTING MANHOLE OR HANDHOLE	EACH	3	3																
	Z0013797	STABILIZED CONSTRUCTION ENTRANCE	SQ YD	1,232	1,120	112															
	Z0013798	CONSTRUCTION LAYOUT	L SUM	1.0	0.7	0.3															
	Z0018500	DRAINAGE STRUCTURES TO BE CLEANED	EACH	20	20																
	Z0030850	TEMPORARY INFORMATION SIGNING	SQ FT	500	500																

MODEL: Default  
 FILE NAME: p:\benesch-pw\benesch-pw\benesch-pw\1\Documents\1\0700510740\_001\Eng\_Docs\_Phase 1\General\162H115-shi-soq-32.dgn



USER NAME = dlevin  
 PLOT SCALE = 2,0000 ' / in.  
 PLOT DATE = 3/22/2022

DESIGNED -  
 DRAWN -  
 CHECKED -  
 DATE - 03/17/2022

REVISED -  
 REVISED -  
 REVISED -  
 REVISED -

**STATE OF ILLINOIS  
DEPARTMENT OF TRANSPORTATION**

**SUMMARY OF QUANTITIES**

SCALE: SHEET OF SHEETS STA. TO STA.

F.A./P RTE.	SECTION	COUNTY	TOTAL SHEETS	SHEET NO.
*	2018-075-R	WILL	1510	40
CONTRACT NO. 62H15				
* FAI 55, FAP 338 ILLINOIS FED. AID PROJECT				



CODE NO.	ITEM DESCRIPTION	UNIT	TOTAL QUANTITY	ROADWAY URBAN			ROADWAY LIGHTING		LED STREET SIGNS SHARED-USE PATH	OVERHEAD SIGNING	OVERHEAD SIGNING	RETAINING WALLS 099-1002 099-1003 099-1004	BRIDGE SN 099-4642	BRIDGE SN 099-4666	EMERGENCY VEHICLE PREEMPTION		TRAFFIC SIGNALS			SHARED-USE PATH	
				0004	0004	0004	IL 59	INTERCHANGE	SEIL ROAD	GATEWAY BOULEVARD	RAMP C				SEIL ROAD	DDI	INTERCONNECT		SEIL ROAD		DDI
				100% STATE	80% FED 20% STATE	100% JOLIET	100% SHOREWOOD	100% STATE	100% SHOREWOOD	100% JOLIET	50% STATE 50% JOLIET				100% STATE	100% STATE	100% SHOREWOOD	100% JOLIET	100% STATE		100% JOLIET
X Z0033020	LUMINAIRE SAFETY CABLE ASSEMBLY	EACH	173							173											
X Z0033028	MAINTENANCE OF LIGHTING SYSTEM	CAL MO	24							24											
X Z0033052	COMMUNICATIONS VAULT	EACH	11	11																	
X Z0033056	OPTIMIZE TRAFFIC SIGNAL SYSTEM	EACH	1														1				
Z0034105	MATERIAL TRANSFER DEVICE	TON	2,721	2,721																	
Z0040530	PIPE UNDERDRAIN REMOVAL	FOOT	2,873	2,763		110															
Z0056608	STORM SEWER (WATER MAIN REQUIREMENTS) 12 INCH	FOOT	362	362																	
Z0056612	STORM SEWER (WATER MAIN REQUIREMENTS) 18 INCH	FOOT	175	175																	
Z0062456	TEMPORARY PAVEMENT	SQ YD	10,280		10,280																
Z0064800	SELECTIVE CLEARING	UNIT	269	269																	
Z0065740	SLOTTED DRAIN 12" WITH VARIABLE SLOT	FOOT	250	250																	
Z0073345	SLEEPER SLAB	FOOT	855	587		268															
Z0073510	TEMPORARY TRAFFIC SIGNAL TIMING	EACH	1																	1	
X A2000214	TREE, ACER X FREEMANII MARMO (MARMO FREEMAN MAPLE), 1-3/4" CALIPER, BALLED AND BURLAPPED	EACH	11	11																	
X A2001612	TREE, ACER SACCHARINUM MORTON (CRESCENDO SUGAR MAPLE), 2" CALIPER, BALLED AND BURLAPPED	EACH	18	18																	
X A2002008	TREE, AESCULUS FLAVEA (YELLOW SWEET BUCKEYE), 2" CALIPER, BALLED AND BURLAPPED	EACH	14	9		5															

MODEL: D:\default\benesch\pwr-9\3Documents\10720\10740\001\ing\_Docs\_Phase 3\General\0162H15-sht-soq-33.dgn  
 FILE NAME: pwr-9\benesch\pwr-9\3Documents\10720\10740\001\ing\_Docs\_Phase 3\General\0162H15-sht-soq-33.dgn



USER NAME = jworthington	DESIGNED - NDAUER	REVISED -
PLOT SCALE = 2.0000' / in.	DRAWN - NDAUER	REVISED -
PLOT DATE = 3/23/2022	CHECKED - POBRIEN	REVISED -
	DATE = 03/25/2022	REVISED -

**STATE OF ILLINOIS  
DEPARTMENT OF TRANSPORTATION**

SUMMARY OF QUANTITIES				
SCALE:	SHEET	OF	SHEETS	STA. TO STA.

F.A./P.RTE.	SECTION	COUNTY	TOTAL SHEETS	SHEET NO.
*	2018-075-R	WILL	1510	41
			CONTRACT NO. 62H15	
* FAI 55, FAP 338		ILLINOIS FED. AID PROJECT		

X = SPECIALTY ITEM				ROADWAY URBAN			ROADWAY LIGHTING		LED STREET SIGNS SHARED-USE PATH	OVERHEAD SIGNING	OVERHEAD SIGNING	RETAINING WALLS 099-1002 099-1003 099-1004	BRIDGE SN 099-4642	BRIDGE SN 099-4666	EMERGENCY VEHICLE PREEMPTION		TRAFFIC SIGNALS			SHARED-USE PATH
CODE NO.	ITEM DESCRIPTION	UNIT	TOTAL QUANTITY	URBAN			IL 59	INTERCHANGE	SEIL ROAD	GATEWAY BOULEVARD	RAMP C			SEIL ROAD	DDI	INTERCONNECT	SEIL ROAD	DDI	SHARED-USE PATH	
				0004	0004	0004	0021	0021	0021	0004	0304	0044	0010	0010	0021	0021	0021	0021	0021	0021
				100% STATE	80% FED 20% STATE	100% JOLIET	100% SHOREWOOD	100% STATE	100% SHOREWOOD	100% JOLIET	50% STATE 50% JOLIET	100% STATE	100% STATE	100% SHOREWOOD	100% JOLIET	100% STATE	100% JOLIET	96.7% STATE 3.3% SHOREWOOD	50% STATE 50% JOLIET	100% STATE
X A2002370	TREE, BETULA NIGRA (RIVER BIRCH), 8' HEIGHT, CLUMP FORM, BALLED AND BURLAPPED	EACH	55	50		5														
X A2002514	TREE, CARPINUS CAROLINIANA (AMERICAN HORNBEAM), 1-3/4" CALIPER, BALLED AND BURLAPPED	EACH	3	3																
X A2002608	TREE, CARYA CORDIFORMIS (BITTERNUT HICKORY), 1" CALIPER, BALLED AND BURLAPPED	EACH	5	5																
X A2002814	TREE, CATALPA SPECIOSA (NORTHERN CATALPA), 1-3/4" CALIPER, BALLED AND BURLAPPED	EACH	18	9		9														
X A2002917	TREE, CELTIS OCCIDENTALIS ULZAM (ULTRA COMMON HACKBERRY), 2" CALIPER, BALLED AND BURLAPPED	EACH	27	17		10														
X A2004616	TREE, GLEDITSIA TRIACANTHOS INERMIS (THORNLESS COMMON HONEYLOCUST), 2" CALIPER, BALLED AND BURLAPPED	EACH	20	14		6														
X A2005016	TREE, GYMNOCLADUS DIOICUS (KENTUCKY COFFEETREE), 2" CALIPER, BALLED AND BURLAPPED	EACH	38	38																
X A2005956	TREE, PLATANUS X ACERIFOLIA MORTON CIRCLE (EXCLAMATION LONDON PLANETREE), 2" CALIPER, TREE FORM, BALLED AND BURLAPPED	EACH	31	16		15														
X A2006414	TREE, QUERCUS ALBA (WHITE OAK), 1-3/4" CALIPER, BALLED AND BURLAPPED	EACH	22	10		12														
X A2006512	TREE, QUERCUS BICOLOR (SWAMP WHITE OAK), 1-1/2" CALIPER, BALLED AND BURLAPPED	EACH	35	28		7														
X A2006612	TREE, QUERCUS IMBRICARIA (SHINGLE OAK), 1-1/2" CALIPER, BALLED AND BURLAPPED	EACH	27	27																
X A2006712	TREE, QUERCUS MACROCARPA (BUR OAK), 1-1/2" CALIPER, BALLED AND BURLAPPED	EACH	25	25																
X A2006812	TREE, QUERCUS MUEHLENBERGII (CHINKAPIN OAK), 1.5" CALIPER, BALLED AND BURLAPPED	EACH	15	15																
X A2007620	TREE, TAXODIUM DISTICHUM (COMMON BALD CYPRESS), 2-1/2" CALIPER, BALLED AND BURLAPPED	EACH	25	25																
X A2007817	TREE, TILIA AMERICANA MCKSENTRY (AMERICAN SENTRY LINDEN), 2" CALIPER, BALLED AND BURLAPPED	EACH	15	5		10														
X A2007870	TREE, TILIA AMERICANA (AMERICAN LINDEN/ BASSWOOD), 8' HEIGHT, CLUMP FORM, BALLED AND BURLAPPED	EACH	18	18																

MODEL: Default  
 FILE NAME: \\benesch-pw-bentley.com\benesch\pww\01\Documents\10700510740\_001\Eng\_Docs\_Phase 1\General\162H115-shs-soq-34.dgn  
 D:\162H115-shs-soq-34.dgn  
 50.107  
 2012/11/30



USER NAME = jworthington  
 PLOT SCALE = 2,0000' / 1" in.  
 PLOT DATE = 3/23/2022

DESIGNED - NDAUER  
 DRAWN - NDAUER  
 CHECKED - POBRIEN  
 DATE - 03/25/2022

REVISED -  
 REVISED -  
 REVISED -  
 REVISED -

**STATE OF ILLINOIS  
 DEPARTMENT OF TRANSPORTATION**

**SUMMARY OF QUANTITIES**

SCALE: SHEET OF SHEETS STA. TO STA.

F.A./P RTE.	SECTION	COUNTY	TOTAL SHEETS	SHEET NO.
*	2018-075-R	WILL	1510	42
CONTRACT NO. 62H15				
* FAI 55, FAP 338	ILLINOIS	FED. AID PROJECT		

CODE NO.	ITEM DESCRIPTION	UNIT	TOTAL QUANTITY	ROADWAY URBAN			ROADWAY LIGHTING		LED STREET SIGNS SHARED-USE PATH	OVERHEAD SIGNING	OVERHEAD SIGNING	RETAINING WALLS 099-1002 099-1003 099-1004	BRIDGE SN 099-4642	BRIDGE SN 099-4666	EMERGENCY VEHICLE PREEMPTION		TRAFFIC SIGNALS			SHARED-USE PATH	
				0004	0004	0004	IL 59	INTERCHANGE	SEIL ROAD	GATEWAY BOULEVARD	RAMP C				SEIL ROAD	DDI	INTERCONNECT		SEIL ROAD		DDI
				100% STATE	80% FED 20% STATE	100% JOLIET	100% SHOREWOOD	100% STATE	100% SHOREWOOD	100% JOLIET	50% STATE 50% JOLIET				100% STATE	100% STATE	100% SHOREWOOD	100% JOLIET	100% STATE		100% JOLIET
X A2012116	TREE, AESCULUS X AUTUMN SPLENDOR (AUTUMN SPLENDOR BUCKEYE), 2" CALIPER, BALLED AND BURLAPPED	EACH	15	5		10															
X A2016614	TREE, QUERCUS ELLIPSOIDALIS (HILL'S OAK), 1-3/4" CALIPER, BALLED AND BURLAPPED	EACH	26	15		11															
X B2000562	TREE, AMELANCHIER CANADENSIS (SHADBLOW SERVICEBERRY), 4' HEIGHT, SHRUB FORM, BALLED AND BURLAPPED	EACH	10	10																	
X B2001664	TREE, CRATAEGUS CRUGALLI INERMIS (THORN LESS COCKSPUR HAWTHORN), 5' HEIGHT, SHRUB FORM, BALLED AND BURLAPPED	EACH	5	5																	
X C2003348	SHRUB, HAMAMELIS VIRGINIANA (COMMON WITCHHAZEL), 4' HEIGHT, BALLED AND BURLAPPED	EACH	20	20																	
X C2C04524	SHRUB, MYRICA PENNSYLVANICA (BAYBERRY), 2' HEIGHT, CONTAINER	EACH	700	700																	
X C2C05718	SHRUB, RHUS AROMATICA (FRAGRANT SUMAC), 18" WIDTH, CONTAINER	EACH	385	135		250															
X C2C05936	SHRUB, RHUS GLABRA (SMOOTH SUMAC), 3' HEIGHT, CONTAINER	EACH	390	390																	
X C2C077G5	SHRUB, ROSA RUGOSA FRAU DAGMAR HARTOPP (FRAU DAGMAR HASTRUP RUGOSA ROSE), CONTAINER GROWN, 5-GALLON	EACH	150			150															
X C2C09636	SHRUB, SAMBUCUS CANADENSIS (AMERICAN ELDER), 3' HEIGHT, CONTAINER	EACH	40	40																	
X D2001715	EVERGREEN, JUNIPERUS VIRGINIANA TAYLOR (TAYLOR RED CEDAR), 6' HEIGHT, BALLED AND BURLAPPED	EACH	35	35																	
X D2001760	EVERGREEN, PICEA ABIES (NORWAY SPRUCE), 5' HEIGHT, BALLED AND BURLAPPED	EACH	63	58		5															
X D2001960	EVERGREEN, PICEA GLAUCA DENSATA (BLACK HILLS SPRUCE), 5' HEIGHT, BALLED AND BURLAPPED	EACH	33	19		14															
X D2002348	EVERGREEN, PINUS FLEXILIS (LIMBER PINE), 4' HEIGHT, BALLED AND BURLAPPED	EACH	31	18		13															
X D2002948	EVERGREEN, PINUS STROBUS (EASTERN WHITE PINE), 4' HEIGHT, BALLED AND BURLAPPED	EACH	10	10																	
X D2003776	EVERGREEN, THUJA OCCIDENTALIS SMARAGD (EMERALD GREEN AMERICAN ARBORVITAE), 5' HEIGHT, BALLED AND BURLAPPED	EACH	185	185																	

MODEL: Default  
 FILE NAME: p:\benesch-arb\benesch-arb\benesch-arb\Documents\10700510740\_001\Eng\_Docs\_Phase II\General\162H15-phs-soq-35.dgn  
 D:\162H15-phs-soq-35.dgn  
 50107  
 2012/11/30



USER NAME = dlevin	DESIGNED -	REVISED -
PLOT SCALE = 2,000' / in.	DRAWN -	REVISED -
PLOT DATE = 3/22/2022	CHECKED -	REVISED -
	DATE - 03/17/2022	REVISED -

**STATE OF ILLINOIS  
DEPARTMENT OF TRANSPORTATION**

**SUMMARY OF QUANTITIES**

SCALE: SHEET OF SHEETS STA. TO STA.

F.A./P. RTE.	SECTION	COUNTY	TOTAL SHEETS	SHEET NO.
*	2018-075-R	WILL	1510	43
CONTRACT NO. 62H15				
* FAI 55, FAP 338 ILLINOIS FED. AID PROJECT				

CODE NO.	ITEM DESCRIPTION	UNIT	TOTAL QUANTITY	ROADWAY URBAN			ROADWAY LIGHTING		LED STREET SIGNS SHARED-USE PATH	OVERHEAD SIGNING	OVERHEAD SIGNING	RETAINING WALLS 099-1002 099-1003 099-1004	BRIDGE SN 099-4642	BRIDGE SN 099-4666	EMERGENCY VEHICLE PREEMPTION		TRAFFIC SIGNALS			SHARED-USE PATH	
				URBAN			IL 59	INTERCHANGE	SEIL ROAD	GATEWAY BOULEVARD	RAMP C				SEIL ROAD	DDI	INTERCONNECT		SEIL ROAD		DDI
				0004	0004	0004	0021	0021	0021	0004	0004				0044	0010	0010	0021	0021		0021
				100% STATE	80% FED 20% STATE	100% JOLIET	100% SHOREWOOD	100% STATE	100% SHOREWOOD	100% JOLIET	50% STATE 50% JOLIET	100% STATE	100% STATE	100% SHOREWOOD	100% JOLIET	100% STATE	100% JOLIET	96.7% STATE 3.3% SHOREWOOD	50% STATE 50% JOLIET	100% STATE	
X E20210G1	VINE-PARTHENOCISSUS QUINQUEFOLIA ENGEL MANNII (ENGELMANNII VIRGINIA CREEPER), 1-GALLON POT	EACH	1,604	1,604																	
X K0012990	PERENNIAL PLANTS, ORNAMENTAL TYPE, GALLON POT	UNIT	5			5															
X K0013030	PERENNIAL PLANTS, WETLAND TYPE, 2" DIAMETER BY 4" DEEP PLUG	UNIT	389	389																	
X K0026850	PERENNIAL PLANT CARE	SQ YD	17,640	17,640																	
X K0029614	WEED CONTROL, AQUATIC	GALLON	3	3																	
X K0029618	WEED CONTROL, BROADLEAF IN TURF	GALLON	10	10																	
X K0029634	WEED CONTROL, PRE-EMERGENT GRANULAR HERBICIDE	POUND	109	74		35															
X X1400504	DIVERGING DIAMOND INTERCHANGE, FULL-ACTUATED CONTROLLER AND TYPE SUPER R CABINET (SPECIAL)	EACH	1																		1
Ø Z0076600	TRAINEES	HOURS	2000	2000																	
Ø Z0076604	TRAINEES - TRAINING PROGRAM GRADUATE	HOURS	2000	2000																	

MODEL: D:\default\benesch\pwr\benesch\pwr-93\Documents\10700\10740\_001\ing\_Docs\_Phase 3\General\0162H15-sht-soo-36.dgn  
 FILE NAME: pwr\benesch\pwr\benesch\pwr-93\Documents\10700\10740\_001\ing\_Docs\_Phase 3\General\0162H15-sht-soo-36.dgn



USER NAME = dlevin	DESIGNED - NDAUER	REVISED -
PLOT SCALE = 2.0000' / in.	DRAWN - NDAUER	REVISED -
PLOT DATE = 3/22/2022	CHECKED - POBRIEN	REVISED -
	DATE - 03/17/2022	REVISED -

**STATE OF ILLINOIS**  
**DEPARTMENT OF TRANSPORTATION**

**SUMMARY OF QUANTITIES**

SCALE: SHEET OF SHEETS STA. TO STA.

F.A./P.RTE.	SECTION	COUNTY	TOTAL SHEETS	SHEET NO.
*	2018-075-R	WILL	1510	44
			CONTRACT NO. 62H15	
* FAI 55, FAP 338		ILLINOIS FED. AID PROJECT		

Ø 0042

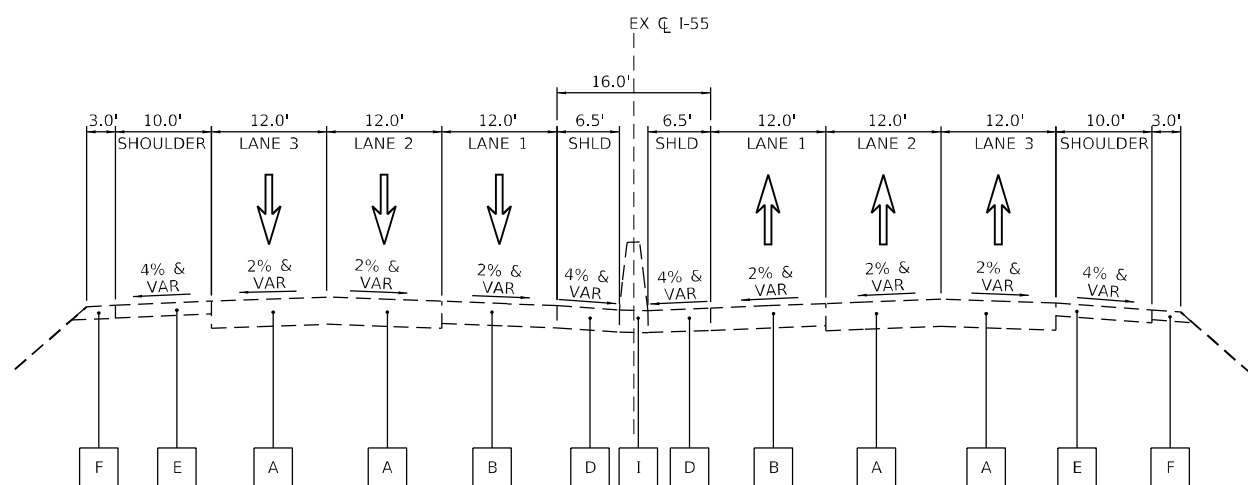

**EXISTING TYPICAL SECTION**

**I-55**

STA 250+67 TO STA 337+24  
TANGENT SECTION SHOWN

**LEGEND**

- A EXISTING COMPOSITE PAVEMENT, 17" (7" HMA OVER 10" PCC)
- B EXISTING HMA PAVEMENT, 14"
- C EXISTING CONCRETE CURB AND GUTTER
- D EXISTING HMA SHOULDER, 14"
- E EXISTING HMA SHOULDER, VARIES 8" TO 12"
- F EXISTING AGGREGATE SHOULDER
- G EXISTING CONCRETE MEDIAN
- H EXISTING GUARDRAIL
- I EXISTING CONCRETE BARRIER AND BASE

MODEL: Default  
 FILE: \\na161c-pw-bentley.com\benesch\pww\01\Documents\107005\10740\_00\Eng\_Docs\_Phase\_1\Roadway\Typical\_Sections\162H15-shi-typical-ex-55-01.dgn



USER NAME = jworthington	DESIGNED - JREAMBILLO	REVISED -
PLOT SCALE = 240,0000' / ft.	DRAWN - AGIBSON	REVISED -
PLOT DATE = 2/7/2022	CHECKED - POBRIEN	REVISED -
	DATE - 02/04/2022	REVISED -

**STATE OF ILLINOIS  
DEPARTMENT OF TRANSPORTATION**

**EXISTING TYPICAL SECTIONS  
I-55**

SCALE: AS SHOWN SHEET OF SHEETS STA. TO STA.

F.A./P RTE.	SECTION	COUNTY	TOTAL SHEETS	SHEET NO.
*	2018-075-R	WILL	1510	45
CONTRACT NO. 62H15				
* FAI 55, FAP 338 ILLINOIS FED. AID PROJECT				

**LEGEND**

- A EXISTING PCC PAVEMENT, 9.75" (JOINED)
- B EXISTING CONCRETE CURB AND GUTTER
- C EXISTING HMA SHOULDER, 8"
- D EXISTING AGGREGATE SHOULDER
- E EXISTING CONCRETE MEDIAN SURFACE, 5"
- F EXISTING GUARDRAIL
- G EXISTING STABILIZED SUBBASE HMA, 4"

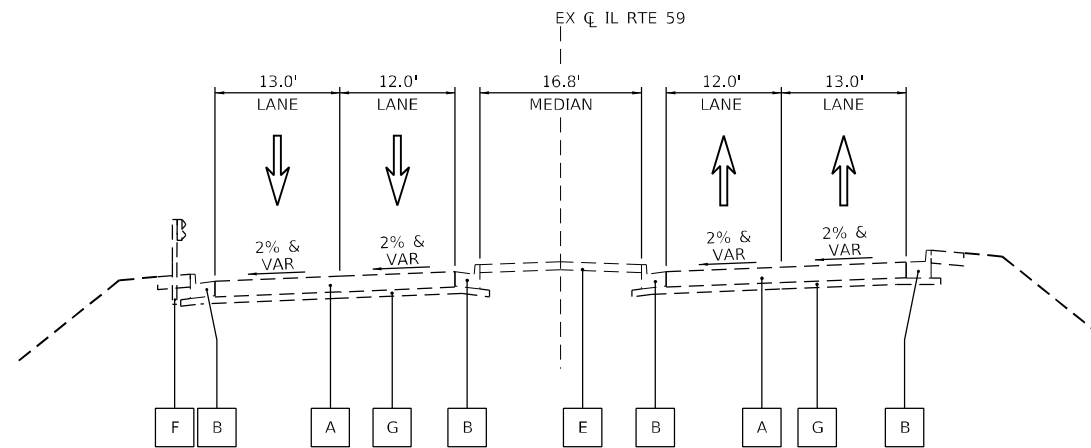

**EXISTING TYPICAL SECTION  
IL RTE 59 NORTH OF SEIL RD**  
(LOOKING NORTH)

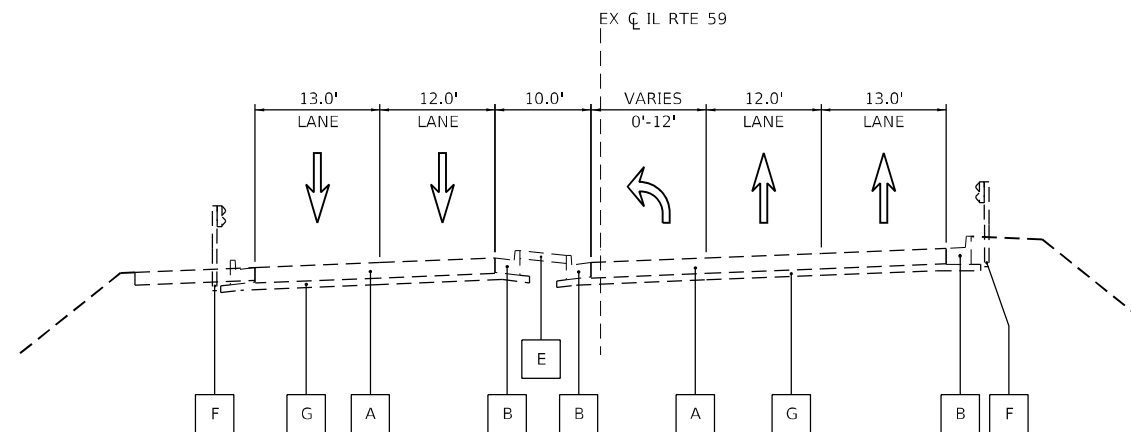

**EXISTING TYPICAL SECTION  
IL RTE 59 SOUTH OF SEIL RD**  
(LOOKING NORTH)

MODEL: Default  
 FILE: \\na16c-pw-bentley.com\benesch-pw\01\Documents\107005\107140\_001\Eng\_Docs\_Phase\_1\Roadway\Typical\_Sections\162H15-shi-typical-ex-59-01.dgn



USER NAME = jworthington  
 PLOT SCALE = 240,0000' / ft.  
 PLOT DATE = 2/7/2022

DESIGNED - JREAMBILLO  
 DRAWN - AGIBSON  
 CHECKED - POBRIEN  
 DATE - 02/04/2022

REVISED -  
 REVISED -  
 REVISED -  
 REVISED -

**STATE OF ILLINOIS  
DEPARTMENT OF TRANSPORTATION**

**EXISTING TYPICAL SECTION  
IL RTE 59**

SCALE: AS SHOWN SHEET OF SHEETS STA. TO STA.

F.A./P RTE.	SECTION	COUNTY	TOTAL SHEETS	SHEET NO.
*	2018-075-R	WILL	1510	46
CONTRACT NO. 62H15				
* FAI 55, FAP 338 ILLINOIS FED. AID PROJECT				



**LEGEND**

- A EXISTING HMA PAVEMENT, 15.75"
- B EXISTING CONCRETE CURB AND GUTTER
- C EXISTING BITUMINOUS SHOULDER
- D EXISTING AGGREGATE SHOULDER
- E EXISTING CONCRETE MEDIAN
- F EXISTING GUARDRAIL
- G EXISTING RETAINING WALL

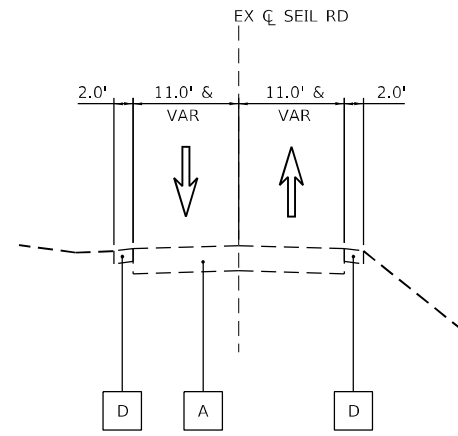

**EXISTING TYPICAL SECTION**

**SEIL RD**

STA 4003+90 TO STA 4008+75

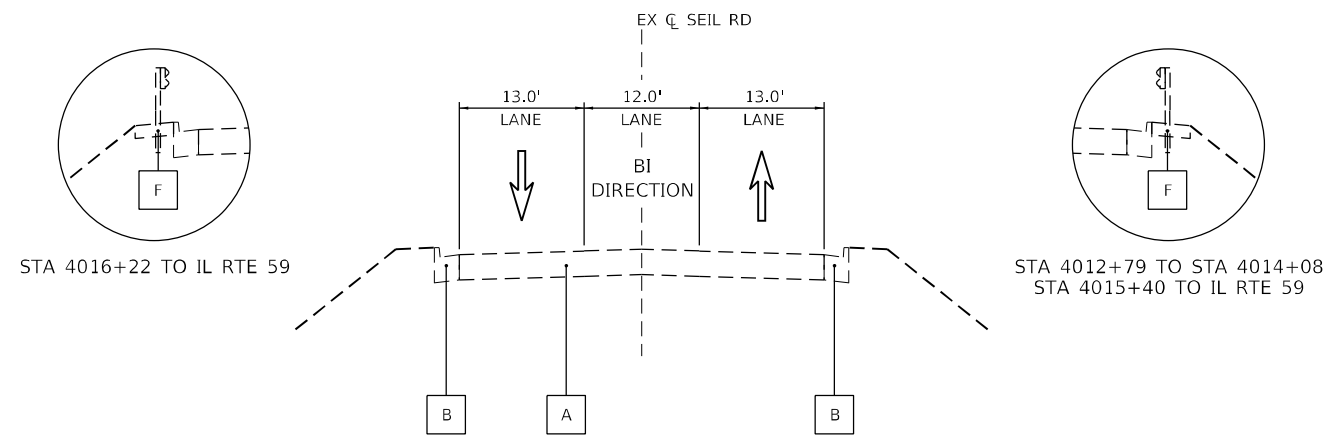

**EXISTING TYPICAL SECTION**

**SEIL RD**

STA 4008+75 TO STA 4014+08  
STA 4015+38 TO STA 4018+17

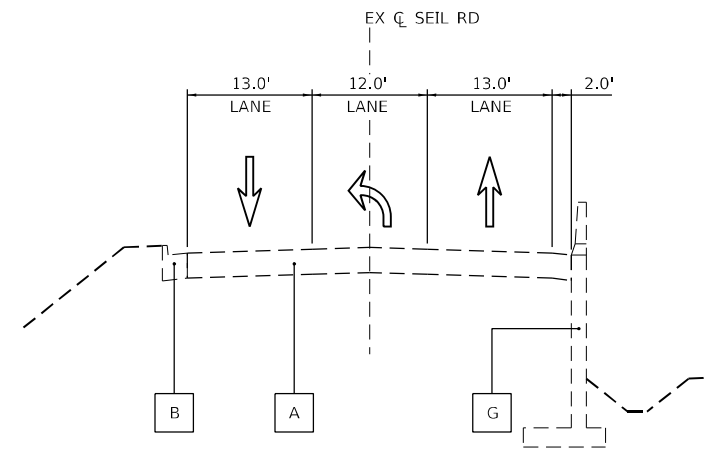

**EXISTING TYPICAL SECTION**

**SEIL RD**

STA 4014+08 TO STA 4015+38

MODEL: Default  
 FILE: \\nafe\p\pub\benesch\pub\benesch.com\benesch\pub\benesch\p\107005\10740\_001\Eng\_Docs\_Phase\_1\Roadway\Typical\_Sections\162H15-shi-typical-ex-seil-01.dgn



USER NAME = jworthington	DESIGNED - JREAMBILLO	REVISED -
	DRAWN - AGIBSON	REVISED -
PLOT SCALE = 240,0000' / ft.	CHECKED - POBRIEN	REVISED -
PLOT DATE = 2/7/2022	DATE - 02/04/2022	REVISED -

**STATE OF ILLINOIS  
DEPARTMENT OF TRANSPORTATION**

**EXISTING TYPICAL SECTION  
SEIL RD**

SCALE: AS SHOWN SHEET OF SHEETS STA. TO STA.

F.A./P.RTE.	SECTION	COUNTY	TOTAL SHEETS	SHEET NO.
*	2018-075-R	WILL	1510	48
CONTRACT NO. 62H15				
* FAI 55, FAP 338 ILLINOIS FED. AID PROJECT				



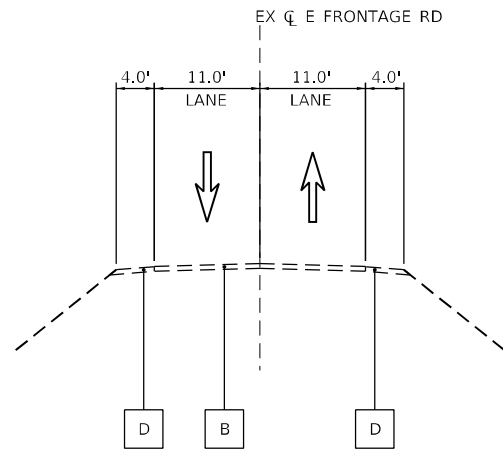

**EXISTING TYPICAL SECTION  
E FRONTAGE RD**

STA 5990+00 TO STA 6013+00  
STA 6043+00 TO STA 6050+16

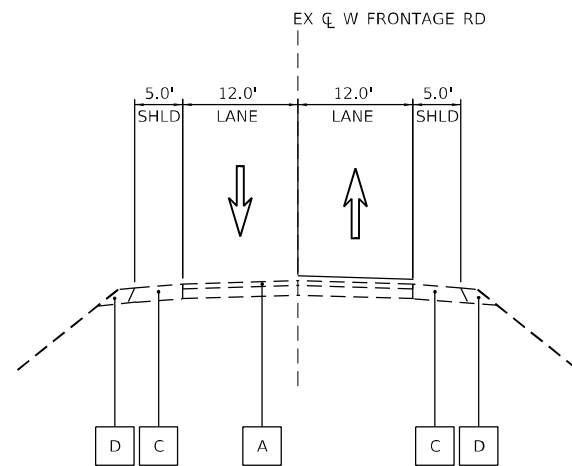

**EXISTING TYPICAL SECTION  
W FRONTAGE RD**

STA 5540+61 TO STA 5543+73

**LEGEND**

- A EXISTING HMA PAVEMENT, 9"
- B EXISTING HMA PAVEMENT, 4"
- C EXISTING HMA SHOULDER, 9"
- D EXISTING AGGREGATE SHOULDER

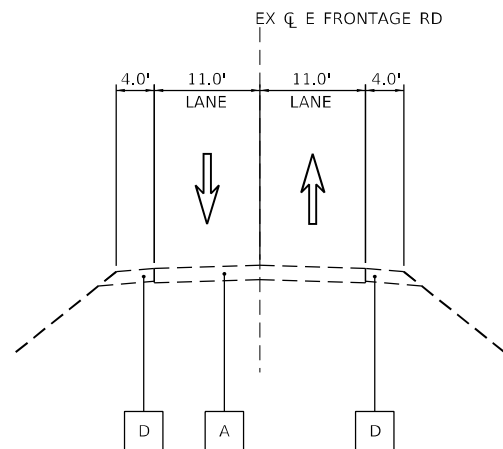

**EXISTING TYPICAL SECTION  
E FRONTAGE RD**

STA 6013+00 TO STA 6043+00

MODEL: Default  
 FILE: \\nafe1-pw-benesch-pw-bentley.com\benesch-pw-01\Documents\10705\10740\_00\Eng\_Docs\_Phase\_1\Roadway\Typical\_Sections\162H15-sh-typical-ex-frontage-01.dgn



USER NAME = jworthington  
 PLOT SCALE = 240,0000 ' / ft.  
 PLOT DATE = 2/7/2022

DESIGNED - JREAMBILLO  
 DRAWN - AGIBSON  
 CHECKED - POBRIEN  
 DATE - 02/04/2022

REVISED -  
 REVISED -  
 REVISED -  
 REVISED -

**STATE OF ILLINOIS  
DEPARTMENT OF TRANSPORTATION**

**EXISTING TYPICAL SECTION  
E AND W FRONTAGE RD**

SCALE: AS SHOWN SHEET OF SHEETS STA. TO STA.

F.A./P RTE.	SECTION	COUNTY	TOTAL SHEETS	SHEET NO.
*	2018-075-R	WILL	1510	49
CONTRACT NO. 62H15				
* FAI 55, FAP 338		ILLINOIS FED. AID PROJECT		

**HOT-MIX ASPHALT MIXTURE REQUIREMENTS**

	MIXTURE TYPE	THICKNESS	AIR VOIDS @ N <sub>DES</sub>	QMP	MTD Required?
<b>HOT-MIX ASPHALT PAVEMENT (FULL-DEPTH), 15"</b>					
<b>I-55 AUXILIARY LANES</b>	POLYMERIZED HOT-MIX ASPHALT SURFACE COURSE, STONE MATRIX ASPHALT, 12.5, MIX "F", N80	2"	3.5% @ 80 Gyr.	QCP	YES
	POLYMERIZED HOT-MIX ASPHALT BINDER COURSE, STONE MATRIX ASPHALT 12.5, N80	2"	3.5% @ 80 Gyr.	QCP	YES
	HOT-MIX ASPHALT BASE COURSE, IL-19.0, N90	11"	4% @ 90 Gyr.	QCP	NO
<b>HOT-MIX ASPHALT PAVEMENT (FULL-DEPTH), 12 3/4"</b>					
<b>RAMP A</b>	POLYMERIZED HOT-MIX ASPHALT SURFACE COURSE, STONE MATRIX ASPHALT, 9.5, MIX "F", N80	2"	3.5% @ 80 Gyr.	QCP	NO
<b>RAMP B</b>					
<b>RAMP C</b>	POLYMERIZED HOT-MIX ASPHALT BINDER COURSE, IL-19.0, N90	2-1/4"	4% @ 90 Gyr.	QCP	NO
<b>RAMP D</b>					
<b>US 52 RAMP D</b>	HOT-MIX ASPHALT BASE COURSE, IL-19.0, N90	8-1/2"	4% @ 90 Gyr.	QCP	NO
<b>HOT-MIX ASPHALT PAVEMENT (FULL-DEPTH), 10 1/4"</b>					
<b>SEIL RD</b>	POLYMERIZED HOT-MIX ASPHALT SURFACE COURSE, IL-9.5, MIX "E", N70	2"	4% @ 70 Gyr.	QC/QA	NO
<b>WEST FRONTAGE ROAD</b>	HOT-MIX ASPHALT BASE COURSE, IL-19.0, N70	8-1/4"	4% @ 70 Gyr.	QCP	NO
<b>HOT-MIX ASPHALT PAVEMENT WIDENING</b>					
<b>WEST FRONTAGE ROAD RESURFACING, 2"</b>	POLYMERIZED HOT-MIX ASPHALT SURFACE COURSE, IL-9.5, MIX "E", N70	2"	4% @ 70 Gyr.	QC/QA	NO
<b>WEST FRONTAGE ROAD BASE COURSE WIDENING, 8 1/4"</b>	HOT-MIX ASPHALT BASE COURSE, WIDENING (HMA BINDER IL-19.0)	8-1/4"	4% @ 70 Gyr.	QC/QA	NO
<b>HOT-MIX ASPHALT PAVEMENT (FULL-DEPTH), 9"</b>					
<b>ROCK RUN CROSSINGS DRIVE</b>	POLYMERIZED HOT-MIX ASPHALT SURFACE COURSE, IL-9.5, MIX "E", N70	2"	4% @ 70 Gyr.	QCP	NO
	HOT-MIX ASPHALT BASE COURSE, IL-19.0, N70	7"	4% @ 70 Gyr.	QCP	NO
<b>HOT-MIX ASPHALT PAVEMENT WIDENING</b>					
<b>ROCK RUN CROSSINGS DRIVE RESURFACING, 2"</b>	POLYMERIZED HOT-MIX ASPHALT SURFACE COURSE, IL-9.5, MIX "E", N70	2"	4% @ 70 Gyr.	QC/QA	NO
<b>ROCK RUN CROSSINGS DRIVE BASE COURSE WIDENING, 7"</b>	HOT-MIX ASPHALT BASE COURSE, WIDENING (HMA BINDER IL-19.0)	7"	4% @ 70 Gyr.	QC/QA	NO
<b>HOT-MIX ASPHALT SHOULDERS, 15"</b>					
<b>I-55 AUXILIARY LANES</b>	HOT-MIX ASPHALT SURFACE COURSE, IL-9.5, MIX "D", N70	2"	4% @ 70 Gyr.	QC/QA	NO
<b>OVERHEAD SIGN SHOULDER RECONSTRUCTION</b>	HOT-MIX ASPHALT BINDER COURSE, IL-19.0, N70	13"	4% @ 70 Gyr.	QC/QA	NO
<b>HOT-MIX ASPHALT SHOULDERS, 12 3/4"</b>					
<b>RAMP A</b>					
<b>RAMP B</b>	HOT-MIX ASPHALT SURFACE COURSE, IL-9.5, MIX "D", N70	2"	4% @ 70 Gyr.	QC/QA	NO
<b>RAMP C</b>					
<b>RAMP D</b>	HOT-MIX ASPHALT BINDER COURSE, IL-19.0, N70	10-3/4"	4% @ 70 Gyr.	QC/QA	NO
<b>US 52 RAMP D</b>					
<b>HOT-MIX ASPHALT SHOULDERS, 8"</b>					
<b>EAST FRONTAGE ROAD</b>	HOT-MIX ASPHALT SURFACE COURSE, IL-9.5, MIX "D", N50	2"	4% @ 50 Gyr.	QC/QA	NO
	HOT-MIX ASPHALT BINDER COURSE, IL-19.0, N50	6"	4% @ 50 Gyr.	QC/QA	NO
<b>HOT-MIX ASPHALT SHARED-USE PATH (4")</b>					
	HOT-MIX ASPHALT SURFACE COURSE, IL-9.5, MIX "D", N50	1-1/2"	4% @ 50 Gyr.	QC/QA	NO
	HOT-MIX ASPHALT BINDER COURSE, IL-19.0, N50	2-1/2"	4% @ 50 Gyr.	QC/QA	NO
<b>HOT-MIX ASPHALT DRIVEWAY PAVEMENT, 10"</b>					
<b>COMMERCIAL ENTRANCE</b>	HOT-MIX ASPHALT SURFACE COURSE, IL-9.5, MIX "D", N50	2"	4% @ 50 Gyr.	QC/QA	NO
	HOT-MIX ASPHALT BASE COURSE (HMA BINDER IL-19.0 mm)	8"	4% @ 50 Gyr.	QC/QA	NO
<b>HOT-MIX ASPHALT DRIVEWAY PAVEMENT, 8"</b>					
<b>PRIVATE ENTRANCE</b>	HOT-MIX ASPHALT SURFACE COURSE, IL-9.5, MIX "D", N50	2"	4% @ 50 Gyr.	QC/QA	NO
	HOT-MIX ASPHALT BASE COURSE (HMA BINDER IL-19.0 mm)	6"	4% @ 50 Gyr.	QC/QA	NO
<b>TEMPORARY PAVEMENT</b>					
	HOT-MIX ASPHALT SURFACE COURSE, IL-9.5, MIX "D", N70	2"	4% @ 70 Gyr.	QC/QA	NO
	HOT-MIX ASPHALT BINDER COURSE, IL-19.0, N70	8"	4% @ 70 Gyr.	QC/QA	NO
<b>TEMPORARY ACCESS (WINTERIZE)</b>	HOT-MIX ASPHALT SURFACE COURSE MIX "D", IL 9.5, N50	2"	4% @ 50 Gyr.	QC/QA	NO
<b>HOT-MIX ASPHALT STABILIZATION 6" AT STEEL PLATE BEAM GUARD RAIL</b>	HOT-MIX ASPHALT BINDER COURSE, IL-19.0, N50	6"	4% @ 50 Gyr.	QC/QA	NO
<b>CLASS D PATCH 12" (SPECIAL)</b>	HOT-MIX ASPHALT SURFACE COURSE, IL-9.5, MIX "D", N70	2"	4% @ 70 Gyr.	QC/QA	NO
	HOT-MIX ASPHALT BINDER COURSE, IL-19.0, N70	10"	4% @ 70 Gyr.	QC/QA	NO
<b>MOT LANE TRANSITION HMA AS DIRECTED BY THE ENGINEER</b>	HOT-MIX ASPHALT SURFACE COURSE, IL-9.5, MIX "D", N70	VARIABLES	4% @ 70 Gyr.	QC/QA	NO
<b>QMP DESIGNATIONS:</b>					
	<b>QUALITY CONTROL/QUALITY ASSURANCE (QC/QA); QUALITY CONTROL FOR PERFORMANCE (QCP); PAY FOR PERFORMANCE (PFP)</b>				

THE UNIT WEIGHT USED TO CALCULATE ALL HOT-MIX ASPHALT SURFACE MIXTURES IS 112 LBS/SQ YD/IN.

ALTERNATE TEMPORARY PAVEMENT:  
PC CONCRETE TEMPORARY PAVEMENT SHALL CONSIST OF CLASS PV CONCRETE MEETING THE REQUIREMENTS OF ARTICLE 1020 OF THE STANDARD SPECIFICATIONS. 8" THICK OVER 4" SUBBASE GRANULAR MATERIAL, TYPE B. TEMPORARY PCC PAVEMENT DOES NOT REQUIRE DOWEL BARS.

THE AC TYPE FOR POLYMERIZED MIXTURE SHALL BE SBS/SBR PG 76-22 AND FOR NON-POLYMERIZED HMA THE "AC TYPE" SHALL BE PG 64-22 UNLESS MODIFIED BY RECLAIMED MATERIALS SPECIFICATIONS.

THE LONGITUDINAL JOINT SEALANT SHALL BE PLACED UNDER THE TOP LIFT OF BINDER COURSE AND UNDER THE SURFACE COURSE FOR RAMP A, B, C, D, US 52 RAMP D AND UNDER THE TOP LIFT OF BASE COURSE AND UNDER THE SURFACE COURSE FOR SEIL RD AND WEST FRONTAGE ROAD.

MODEL: Default; FILE: hma15-shi-typical-HMA-01.dgn; Phase: Roadway/Typical; Sections: D162H15-shi-typical-HMA-01.dgn



USER NAME = dlevin	DESIGNED - JREAMBILLO	REVISED -
PLOT SCALE = 240,0000' / ft.	DRAWN - SPOPOVICI	REVISED -
PLOT DATE = 3/16/2022	CHECKED - POBRIEN	REVISED -
	DATE - 03/17/2022	REVISED -

**STATE OF ILLINOIS  
DEPARTMENT OF TRANSPORTATION**

**HMA MIXTURE REQUIREMENTS**

SCALE: NONE SHEET OF SHEETS STA. TO STA.

F.A./P.RTE.	SECTION	COUNTY	TOTAL SHEETS	SHEET NO.
*	2018-075-R	WILL	1510	50
CONTRACT NO. 62H15				
* FAI 55, FAP 338 ILLINOIS FED. AID PROJECT				

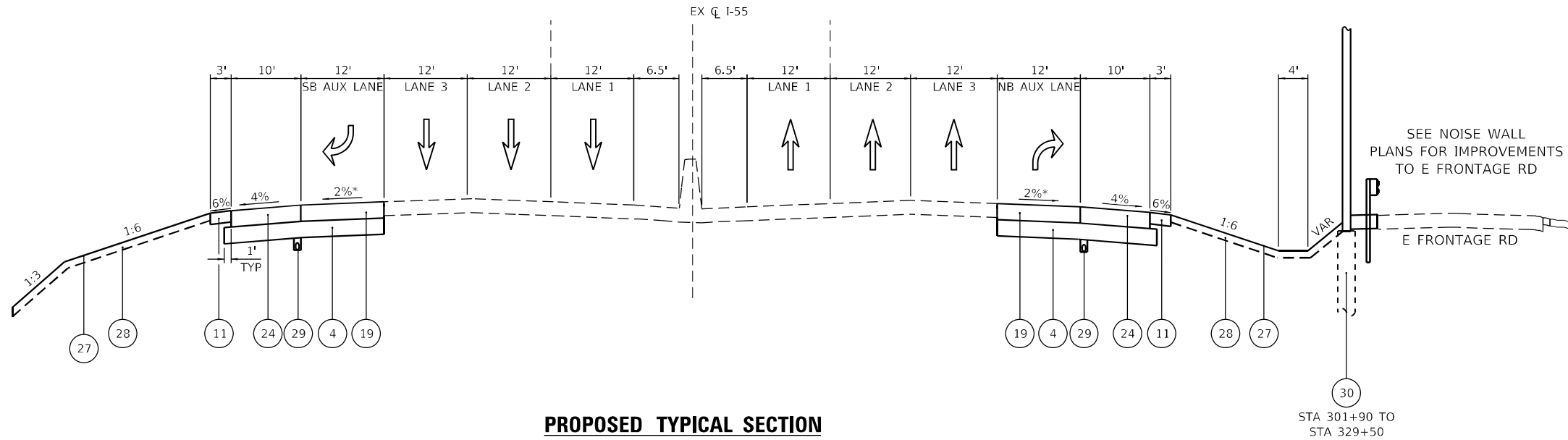

**PROPOSED TYPICAL SECTION**  
**I-55**

STA 288+00 TO STA 330+10.54

\* AUXILIARY LANE CROSS SLOPE IS 2% OR MATCH ADJACENT LANE 3 IN SUPERELEVATED CURVE AND TRANSITIONS.

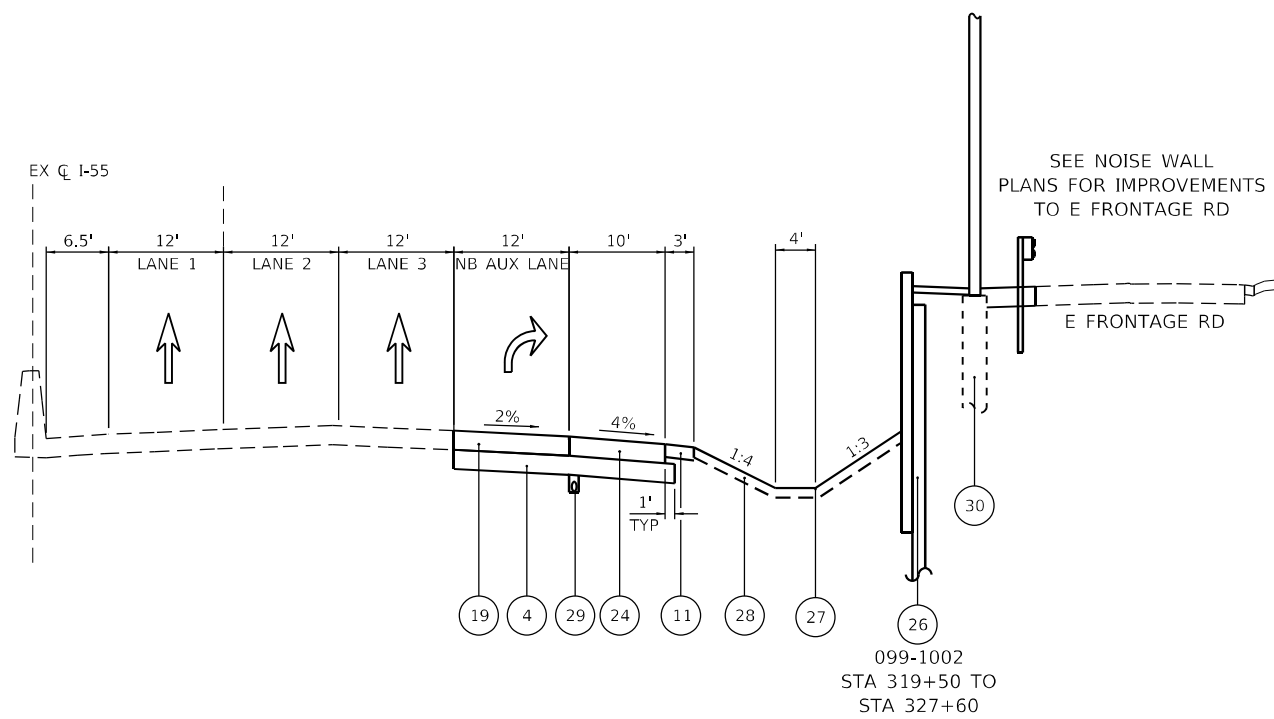

**PROPOSED TYPICAL SECTION**  
**I-55 (NORTHBOUND)**

STA 319+50 TO STA 327+60

**LEGEND**

- 1 PORTLAND CEMENT CONCRETE PAVEMENT, 10" (JOINTED)
- 2 HOT-MIX ASPHALT PAVEMENT (FULL-DEPTH), 12.75"
- 3 HOT-MIX ASPHALT PAVEMENT (FULL-DEPTH), 10.25"
- 4 AGGREGATE SUBGRADE IMPROVEMENT, 12"
- 5 COMBINATION CONCRETE CURB AND GUTTER, TYPE B-6.24
- 6 COMBINATION CONCRETE CURB AND GUTTER, TYPE B-9.24
- 7 COMBINATION CONCRETE CURB AND GUTTER, TYPE M-4.24
- 8 HOT-MIX ASPHALT SHOULDERS, 12.75"
- 9 HOT-MIX ASPHALT PAVEMENT (FULL DEPTH), 9"
- 10 PORTLAND CEMENT CONCRETE SHOULDERS, 10"
- 11 AGGREGATE SHOULDERS, TYPE B 10"
- 12 TYPE B GUTTER
- 13 STAMPED COLORED PORTLAND CEMENT CONCRETE MEDIAN SURFACE, 6 INCH
- 14 CONCRETE MEDIAN, TYPE SB (SPECIAL)
- 15 CONCRETE MEDIAN SURFACE, 5 INCH
- 16 HOT-MIX ASPHALT SHARED-USE PATH (4")
- 17 PORTLAND CEMENT CONCRETE SIDEWALK 5 INCH
- 18 SUBBASE GRANULAR MATERIAL, TYPE B 6"
- 19 HOT-MIX ASPHALT PAVEMENT (FULL DEPTH), 15"
- 20 STEEL PLATE BEAM GUARDRAIL, TYPE A, 6 FOOT POSTS
- 21 HOT-MIX ASPHALT STABILIZATION 6" AT STEEL PLATE BEAM GUARD RAIL
- 22 CONCRETE BARRIER, SINGLE FACE, 44 INCH HEIGHT
- 23 HOT-MIX ASPHALT SURFACE COURSE, 1 1/2"
- 24 HOT-MIX ASPHALT SHOULDERS, 15"
- 25 HOT-MIX ASPHALT BINDER COURSE, 2 1/2"
- 26 RETAINING WALL (SEE STRUCTURAL PLANS)
- 27 SEEDING
- 28 TOPSOIL EXCAVATION AND PLACEMENT
- 29 PIPE UNDERDRAINS 6"
- 30 NOISE ABATEMENT WALL, GROUND MOUNTED

**NOTES**

1. AT ROADWAY LOCATIONS WITH CURB AND GUTTER, THE PROPOSED GUARDRAIL FACE SHALL ALIGN WITH THE BACK OF CURB.
2. SEE HOT-MIX ASPHALT MIXTURE REQUIREMENTS CHART FOR MIXTURE DESIGN.
3. CURB AND GUTTER WITH REVERSE PITCH GUTTER SHALL MATCH THE ADJACENT PAVEMENT LANE SLOPE.
4. SHARED-USE PATH SHALL BE COMPLIANT WITH THE AMERICANS WITH DISABILITIES ACT (ADA). FOR SHARED-USE PATH THE MAXIMUM RUNNING SLOPE IS 5%, MAXIMUM CROSS SLOPE IS 2%, AND MAXIMUM RAMP SLOPE IS 8.33%.
5. SIDE CURB ADJACENT TO PCC SHARED-USE PATH WILL BE MEASURED IN PLAN VIEW BY THE SQ FT AND PAID FOR AS PORTLAND CEMENT CONCRETE SIDEWALK, 5".
6. TRANSVERSE CONTRACTION JOINTS IN THE PCC SHARED-USE PATH SHALL BE SAWED NOT TOOLED.
7. THE AGGREGATE GRADATION FOR THE AGGREGATE SUBGRADE IMPROVEMENT 12" LOWER LIFT SHALL BE CS 1 OR RR 1.

MODEL: Default  
 FILE NAME: pr-benesch-pw-bentley.com-benesch-pw-01\Documents\107005\10740\_00\Eng\_Docs\_Phase\_1\Roadway\Typical\_Sections\162H15-shi-typical-pr-55-01.dgn  
 D:\62H15-shi-typical-pr-55-01.dgn  
 51274  
 2012/11/30



USER NAME = jworthington	DESIGNED - JREAMBILLO	REVISED -
	DRAWN - SPOPOVICI	REVISED -
PLOT SCALE = 240,0000' / ft.	CHECKED - POBRIEN	REVISED -
PLOT DATE = 2/7/2022	DATE - 02/04/2022	REVISED -

**STATE OF ILLINOIS**  
**DEPARTMENT OF TRANSPORTATION**

**PROPOSED TYPICAL SECTIONS**  
**I-55**

SCALE: AS SHOWN SHEET OF SHEETS STA. TO STA.

F.A./P.RTE.	SECTION	COUNTY	TOTAL SHEETS	SHEET NO.
*	2018-075-R	WILL	1510	51
CONTRACT NO. 62H15				
* FAI 55, FAP 338 ILLINOIS FED. AID PROJECT				

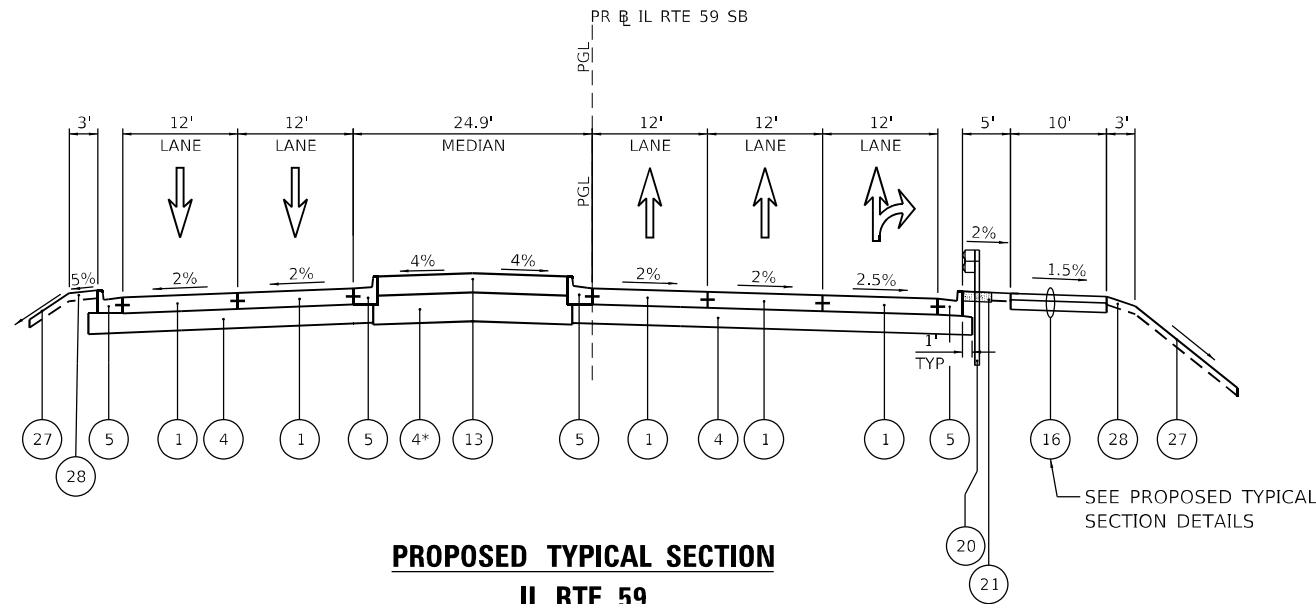

**PROPOSED TYPICAL SECTION  
IL RTE 59**

STA 6992+38 TO STA 6999+58

\* ADDITIONAL THICKNESS OVER 12" IS INCLUDED IN THE COST OF THE ITEM.

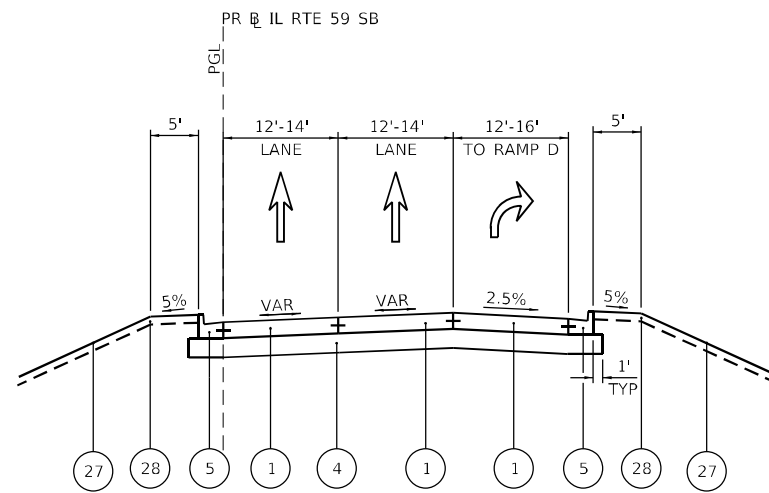

**PROPOSED TYPICAL SECTION  
SOUTHBOUND IL RTE 59**

STA 7002+20 TO STA 7006+52

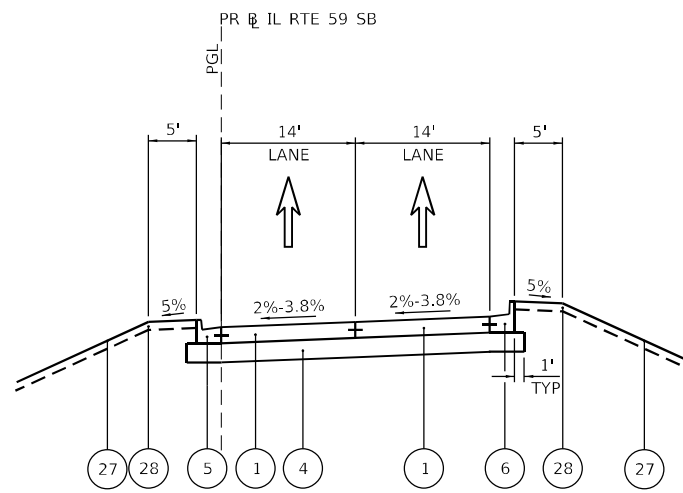

**PROPOSED TYPICAL SECTION  
SOUTHBOUND IL RTE 59**

STA 7007+25 TO STA 7015+65  
STA 7020+02 TO STA 7023+30

**LEGEND**

- 1 PORTLAND CEMENT CONCRETE PAVEMENT, 10" (JOINTED)
- 2 HOT-MIX ASPHALT PAVEMENT (FULL-DEPTH), 12.75"
- 3 HOT-MIX ASPHALT PAVEMENT (FULL-DEPTH), 10.25"
- 4 AGGREGATE SUBGRADE IMPROVEMENT, 12"
- 5 COMBINATION CONCRETE CURB AND GUTTER, TYPE B-6.24
- 6 COMBINATION CONCRETE CURB AND GUTTER, TYPE B-9.24
- 7 COMBINATION CONCRETE CURB AND GUTTER, TYPE M-4.24
- 8 HOT-MIX ASPHALT SHOULDERS, 12.75"
- 9 HOT-MIX ASPHALT PAVEMENT (FULL DEPTH), 9"
- 10 PORTLAND CEMENT CONCRETE SHOULDERS, 10"
- 11 AGGREGATE SHOULDERS, TYPE B 10"
- 12 TYPE B GUTTER
- 13 STAMPED COLORED PORTLAND CEMENT CONCRETE MEDIAN SURFACE, 6 INCH
- 14 CONCRETE MEDIAN, TYPE SB (SPECIAL)
- 15 CONCRETE MEDIAN SURFACE, 5 INCH
- 16 HOT-MIX ASPHALT SHARED-USE PATH (4")
- 17 PORTLAND CEMENT CONCRETE SIDEWALK 5 INCH
- 18 SUBBASE GRANULAR MATERIAL, TYPE B 6"
- 19 HOT-MIX ASPHALT PAVEMENT (FULL DEPTH), 15"
- 20 STEEL PLATE BEAM GUARDRAIL, TYPE A, 6 FOOT POSTS
- 21 HOT-MIX ASPHALT STABILIZATION 6" AT STEEL PLATE BEAM GUARD RAIL
- 22 CONCRETE BARRIER, SINGLE FACE, 44 INCH HEIGHT
- 23 HOT-MIX ASPHALT SURFACE COURSE, 1 1/2"
- 24 HOT-MIX ASPHALT SHOULDERS, 15"
- 25 HOT-MIX ASPHALT BINDER COURSE, 2 1/2"
- 26 RETAINING WALL (SEE STRUCTURAL PLANS)
- 27 SEEDING
- 28 TOPSOIL EXCAVATION AND PLACEMENT
- 29 PIPE UNDERDRAINS 6"
- 30 NOISE ABATEMENT WALL, GROUND MOUNTED

**NOTES**

1. AT ROADWAY LOCATIONS WITH CURB AND GUTTER, THE PROPOSED GUARDRAIL FACE SHALL ALIGN WITH THE BACK OF CURB.
2. SEE HOT-MIX ASPHALT MIXTURE REQUIREMENTS CHART FOR MIXTURE DESIGN.
3. CURB AND GUTTER WITH REVERSE PITCH GUTTER SHALL MATCH THE ADJACENT PAVEMENT LANE SLOPE.
4. SHARED-USE PATH SHALL BE COMPLIANT WITH THE AMERICANS WITH DISABILITIES ACT (ADA). FOR SHARED-USE PATH THE MAXIMUM RUNNING SLOPE IS 5%, MAXIMUM CROSS SLOPE IS 2%, AND MAXIMUM RAMP SLOPE IS 8.33%.
5. SIDE CURB ADJACENT TO PCC SHARED-USE PATH WILL BE MEASURED IN PLAN VIEW BY THE SQ FT AND PAID FOR AS PORTLAND CEMENT CONCRETE SIDEWALK, 5".
6. TRANSVERSE CONTRACTION JOINTS IN THE PCC SHARED-USE PATH SHALL BE SAWED NOT TOOLED.
7. THE AGGREGATE GRADATION FOR THE AGGREGATE SUBGRADE IMPROVEMENT 12" LOWER LIFT SHALL BE CS 1 OR RR 1.

MODEL: Default  
 FILE: M:\MISC\proj\benesch-pw\benesch-pw\11\Documents\1107005\1107140\_001\Eng\_Docs\_Phase\_11\Roadway\Typical\_Sections\1162H15-shi-typical-pr-59-01.dgn  
 D:\62H15-shi-typical-pr-59-01.dgn  
 51274  
 2012/11/30



USER NAME = jworthington	DESIGNED - JREAMBILLO	REVISED -
PLOT SCALE = 240,0000' / ft.	DRAWN - SPOPOVICI	REVISED -
PLOT DATE = 2/7/2022	CHECKED - POBRIEN	REVISED -
	DATE - 02/04/2022	REVISED -

**STATE OF ILLINOIS  
DEPARTMENT OF TRANSPORTATION**

**PROPOSED TYPICAL SECTION  
IL RTE 59**

SCALE: AS SHOWN SHEET OF SHEETS STA. TO STA.

F.A./P.RTE.	SECTION	COUNTY	TOTAL SHEETS	SHEET NO.
*	2018-075-R	WILL	1510	52
			CONTRACT NO. 62H15	
* FAI 55, FAP 338		ILLINOIS FED. AID PROJECT		

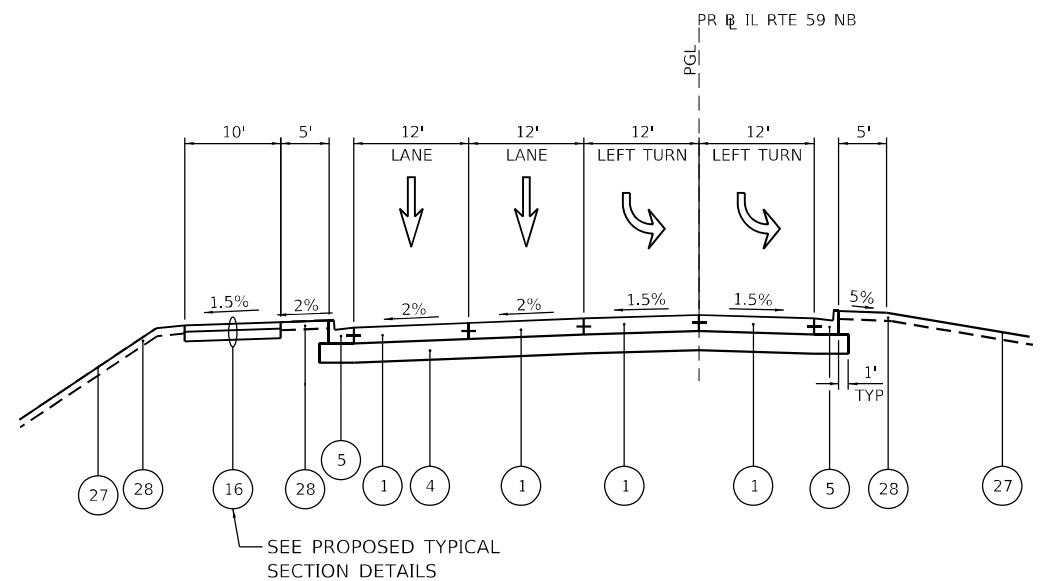

**PROPOSED TYPICAL SECTION**  
**NORTHBOUND IL RTE 59**  
 STA 8002+10 TO STA 8005+30

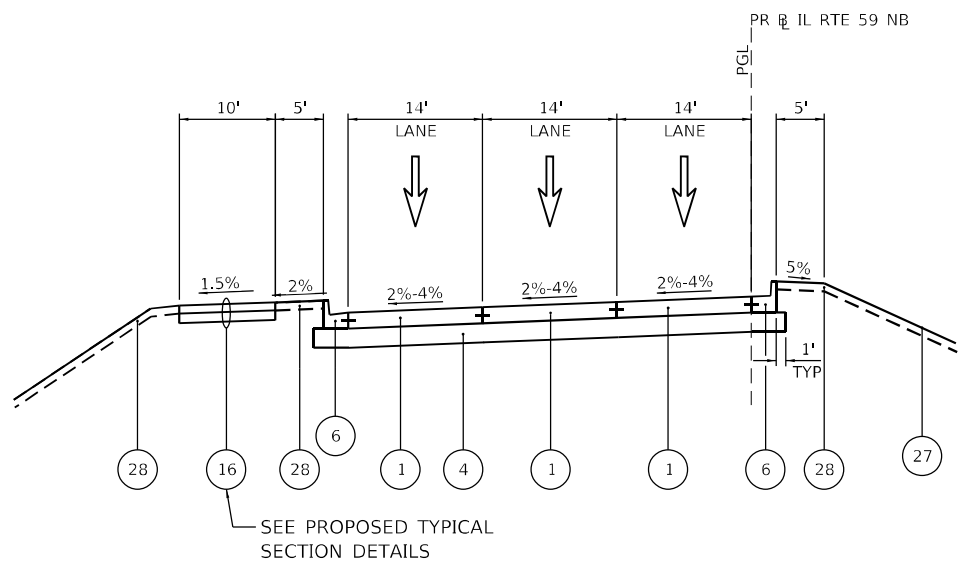

**PROPOSED TYPICAL SECTION**  
**NORTHBOUND IL RTE 59**  
 STA 8007+10 TO STA 8011+09\*  
 STA 8020+42 TO STA 8024+45  
 \*PAVEMENT TRANSITIONS TO THE RIGHT  
 FROM STATION 8011+09 TO 8022+24

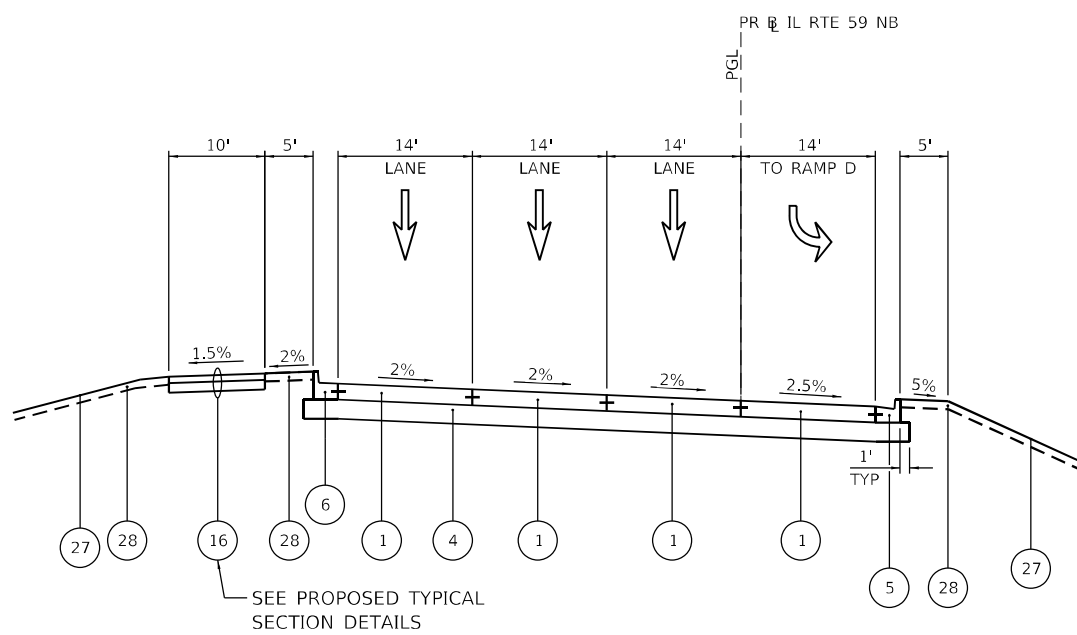

**PROPOSED TYPICAL SECTION**  
**NORTHBOUND IL RTE 59**  
 STA 8013+85 TO STA 8015+00

**LEGEND**

- 1 PORTLAND CEMENT CONCRETE PAVEMENT, 10" (JOINTED)
- 2 HOT-MIX ASPHALT PAVEMENT (FULL-DEPTH), 12.75"
- 3 HOT-MIX ASPHALT PAVEMENT (FULL-DEPTH), 10.25"
- 4 AGGREGATE SUBGRADE IMPROVEMENT, 12"
- 5 COMBINATION CONCRETE CURB AND GUTTER, TYPE B-6.24
- 6 COMBINATION CONCRETE CURB AND GUTTER, TYPE B-9.24
- 7 COMBINATION CONCRETE CURB AND GUTTER, TYPE M-4.24
- 8 HOT-MIX ASPHALT SHOULDERS, 12.75"
- 9 HOT-MIX ASPHALT PAVEMENT (FULL DEPTH), 9"
- 10 PORTLAND CEMENT CONCRETE SHOULDERS, 10"
- 11 AGGREGATE SHOULDERS, TYPE B 10"
- 12 TYPE B GUTTER
- 13 STAMPED COLORED PORTLAND CEMENT CONCRETE MEDIAN SURFACE, 6 INCH
- 14 CONCRETE MEDIAN, TYPE SB (SPECIAL)
- 15 CONCRETE MEDIAN SURFACE, 5 INCH
- 16 HOT-MIX ASPHALT SHARED-USE PATH (4")
- 17 PORTLAND CEMENT CONCRETE SIDEWALK 5 INCH
- 18 SUBBASE GRANULAR MATERIAL, TYPE B 6"
- 19 HOT-MIX ASPHALT PAVEMENT (FULL DEPTH), 15"
- 20 STEEL PLATE BEAM GUARDRAIL, TYPE A, 6 FOOT POSTS
- 21 HOT-MIX ASPHALT STABILIZATION 6" AT STEEL PLATE BEAM GUARD RAIL
- 22 CONCRETE BARRIER, SINGLE FACE, 44 INCH HEIGHT
- 23 HOT-MIX ASPHALT SURFACE COURSE, 1 1/2"
- 24 HOT-MIX ASPHALT SHOULDERS, 15"
- 25 HOT-MIX ASPHALT BINDER COURSE, 2 1/2"
- 26 RETAINING WALL (SEE STRUCTURAL PLANS)
- 27 SEEDING
- 28 TOPSOIL EXCAVATION AND PLACEMENT
- 29 PIPE UNDERDRAINS 6"
- 30 NOISE ABATEMENT WALL, GROUND MOUNTED

**NOTES**

1. AT ROADWAY LOCATIONS WITH CURB AND GUTTER, THE PROPOSED GUARDRAIL FACE SHALL ALIGN WITH THE BACK OF CURB.
2. SEE HOT-MIX ASPHALT MIXTURE REQUIREMENTS CHART FOR MIXTURE DESIGN.
3. CURB AND GUTTER WITH REVERSE PITCH GUTTER SHALL MATCH THE ADJACENT PAVEMENT LANE SLOPE.
4. SHARED-USE PATH SHALL BE COMPLIANT WITH THE AMERICANS WITH DISABILITIES ACT (ADA). FOR SHARED-USE PATH THE MAXIMUM RUNNING SLOPE IS 5%, MAXIMUM CROSS SLOPE IS 2%, AND MAXIMUM RAMP SLOPE IS 8.33%.
5. SIDE CURB ADJACENT TO PCC SHARED-USE PATH WILL BE MEASURED IN PLAN VIEW BY THE SQ FT AND PAID FOR AS PORTLAND CEMENT CONCRETE SIDEWALK, 5".
6. TRANSVERSE CONTRACTION JOINTS IN THE PCC SHARED-USE PATH SHALL BE SAWED NOT TOOLED.
7. THE AGGREGATE GRADATION FOR THE AGGREGATE SUBGRADE IMPROVEMENT 12" LOWER LIFT SHALL BE CS 1 OR RR 1.

MODEL: Default  
 FILE: M:\MFC\_Plan\benesch-pw-bentley.com\benesch-pw-01\Documents\107005\107040\_001\Eng\_Docs\_Phase\_1\Roadway\Typical\_Sections\162H15-shi-typical-pr-59-02.dgn  
 D:\62H15-shi-typical-pr-59-02.dgn  
 51274  
 2012/11/30



USER NAME = jworthington	DESIGNED - JREAMBILLO	REVISED -
	DRAWN - SPOPOVICI	REVISED -
PLOT SCALE = 240,0000' / ft.	CHECKED - POBRIEN	REVISED -
PLOT DATE = 2/7/2022	DATE - 02/04/2022	REVISED -

**STATE OF ILLINOIS**  
**DEPARTMENT OF TRANSPORTATION**

<b>PROPOSED TYPICAL SECTION</b>	
<b>IL RTE 59</b>	
SCALE: AS SHOWN	SHEET OF SHEETS
STA. TO STA.	

F.A./P RTE.	SECTION	COUNTY	TOTAL SHEETS	SHEET NO.
*	2018-075-R	WILL	1510	53
CONTRACT NO. 62H15				
* FAI 55, FAP 338 ILLINOIS FED. AID PROJECT				

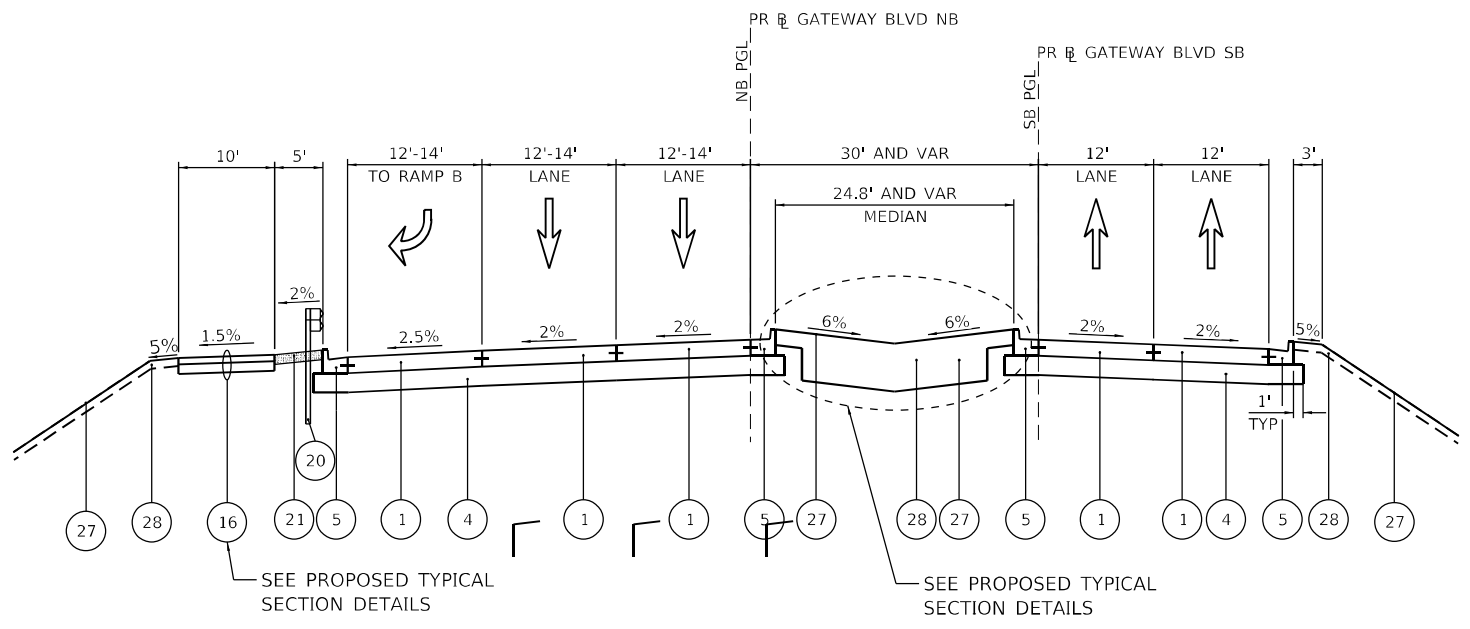

**PROPOSED TYPICAL SECTION  
NORTHBOUND GATEWAY BLVD**  
STA 8025+30 TO STA 8034+00

**PROPOSED TYPICAL SECTION  
SOUTHBOUND GATEWAY BLVD**  
STA 7027+00 TO STA 7035+50

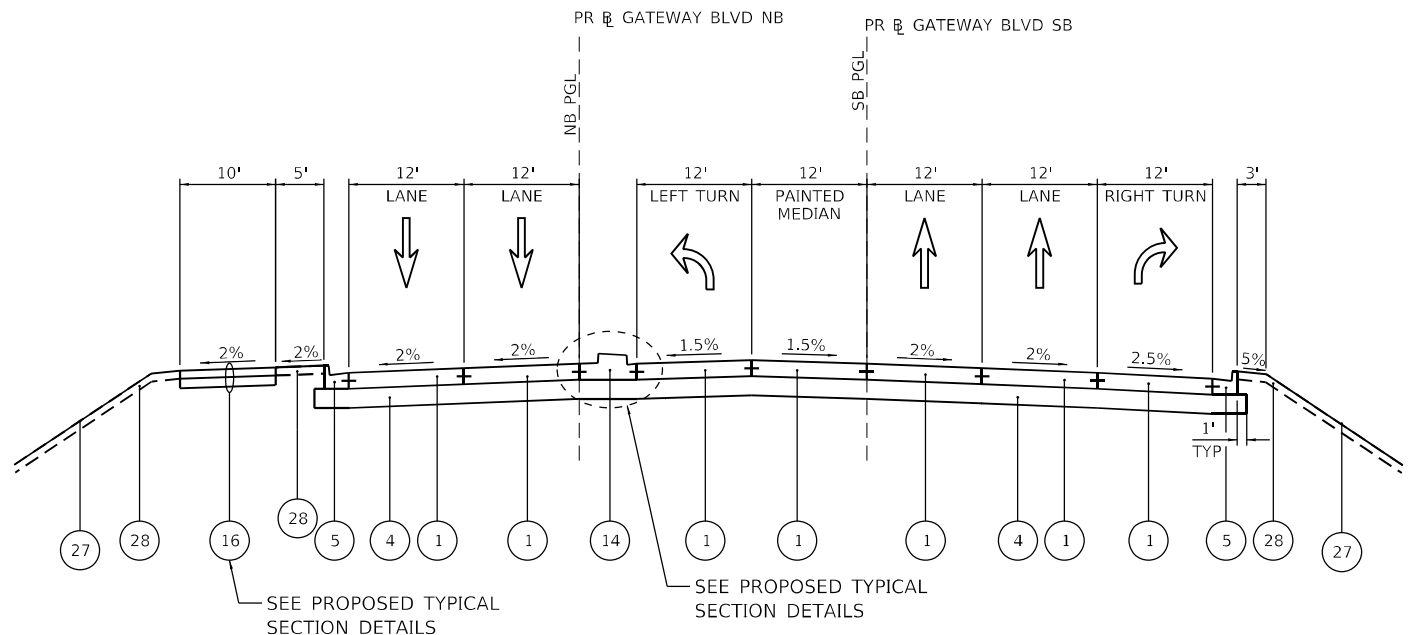

**PROPOSED TYPICAL SECTION  
NORTHBOUND GATEWAY BLVD**  
STA 8034+25 TO STA 8035+75

**PROPOSED TYPICAL SECTION  
SOUTHBOUND GATEWAY BLVD**  
STA 7035+85 TO STA 7037+35

**LEGEND**

- 1 PORTLAND CEMENT CONCRETE PAVEMENT, 10" (JOINTED)
- 2 HOT-MIX ASPHALT PAVEMENT (FULL-DEPTH), 12.75"
- 3 HOT-MIX ASPHALT PAVEMENT (FULL-DEPTH), 10.25"
- 4 AGGREGATE SUBGRADE IMPROVEMENT, 12"
- 5 COMBINATION CONCRETE CURB AND GUTTER, TYPE B-6.24
- 6 COMBINATION CONCRETE CURB AND GUTTER, TYPE B-9.24
- 7 COMBINATION CONCRETE CURB AND GUTTER, TYPE M-4.24
- 8 HOT-MIX ASPHALT SHOULDERS, 12.75"
- 9 HOT-MIX ASPHALT PAVEMENT (FULL DEPTH), 9"
- 10 PORTLAND CEMENT CONCRETE SHOULDERS, 10"
- 11 AGGREGATE SHOULDERS, TYPE B 10"
- 12 TYPE B GUTTER
- 13 STAMPED COLORED PORTLAND CEMENT CONCRETE MEDIAN SURFACE, 6 INCH
- 14 CONCRETE MEDIAN, TYPE SB (SPECIAL)
- 15 CONCRETE MEDIAN SURFACE, 5 INCH
- 16 HOT-MIX ASPHALT SHARED-USE PATH (4")
- 17 PORTLAND CEMENT CONCRETE SIDEWALK 5 INCH
- 18 SUBBASE GRANULAR MATERIAL, TYPE B 6"
- 19 HOT-MIX ASPHALT PAVEMENT (FULL DEPTH), 15"
- 20 STEEL PLATE BEAM GUARDRAIL, TYPE A, 6 FOOT POSTS
- 21 HOT-MIX ASPHALT STABILIZATION 6" AT STEEL PLATE BEAM GUARD RAIL
- 22 CONCRETE BARRIER, SINGLE FACE, 44 INCH HEIGHT
- 23 HOT-MIX ASPHALT SURFACE COURSE, 1 1/2"
- 24 HOT-MIX ASPHALT SHOULDERS, 15"
- 25 HOT-MIX ASPHALT BINDER COURSE, 2 1/2"
- 26 RETAINING WALL (SEE STRUCTURAL PLANS)
- 27 SEEDING
- 28 TOPSOIL EXCAVATION AND PLACEMENT
- 29 PIPE UNDERDRAINS 6"
- 30 NOISE ABATEMENT WALL, GROUND MOUNTED

**NOTES**

1. AT ROADWAY LOCATIONS WITH CURB AND GUTTER, THE PROPOSED GUARDRAIL FACE SHALL ALIGN WITH THE BACK OF CURB.
2. SEE HOT-MIX ASPHALT MIXTURE REQUIREMENTS CHART FOR MIXTURE DESIGN.
3. CURB AND GUTTER WITH REVERSE PITCH GUTTER SHALL MATCH THE ADJACENT PAVEMENT LANE SLOPE.
4. SHARED-USE PATH SHALL BE COMPLIANT WITH THE AMERICANS WITH DISABILITIES ACT (ADA). FOR SHARED-USE PATH THE MAXIMUM RUNNING SLOPE IS 5%, MAXIMUM CROSS SLOPE IS 2%, AND MAXIMUM RAMP SLOPE IS 8.33%.
5. SIDE CURB ADJACENT TO PCC SHARED-USE PATH WILL BE MEASURED IN PLAN VIEW BY THE SQ FT AND PAID FOR AS PORTLAND CEMENT CONCRETE SIDEWALK, 5".
6. TRANSVERSE CONTRACTION JOINTS IN THE PCC SHARED-USE PATH SHALL BE SAWED NOT TOOLED.
7. THE AGGREGATE GRADATION FOR THE AGGREGATE SUBGRADE IMPROVEMENT 12" LOWER LIFT SHALL BE CS 1 OR RR 1.

MODEL: Default; FILE: M:\MFC\_Plan\benesch-plan\benesch-plan\01\Documents\107005\107140\_001\Eng\_Docs\_T\Roadway\Typical\_Sections\162\115-sh-typical-pr-oc-01.dgn



USER NAME = jworthington	DESIGNED - JREAMBILLO	REVISED -
PLOT SCALE = 240,0000' / ft.	DRAWN - SPOPOVICI	REVISED -
PLOT DATE = 2/7/2022	CHECKED - POBRIEN	REVISED -
	DATE - 02/04/2022	REVISED -

**STATE OF ILLINOIS  
DEPARTMENT OF TRANSPORTATION**

<b>PROPOSED TYPICAL SECTIONS GATEWAY BLVD</b>	
SCALE: AS SHOWN	SHEET OF SHEETS
STA. TO STA.	

F.A./P RTE.	SECTION	COUNTY	TOTAL SHEETS	SHEET NO.
	2018-075-R	WILL	1510	54
CONTRACT NO. 62H15				
* FAI 55, FAP 338 ILLINOIS FED. AID PROJECT				

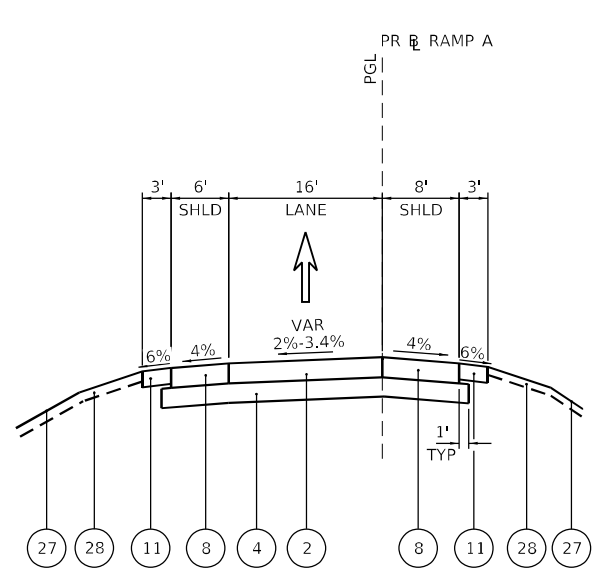

**PROPOSED TYPICAL SECTION  
RAMP A**

STA 904+55 TO STA 907+85

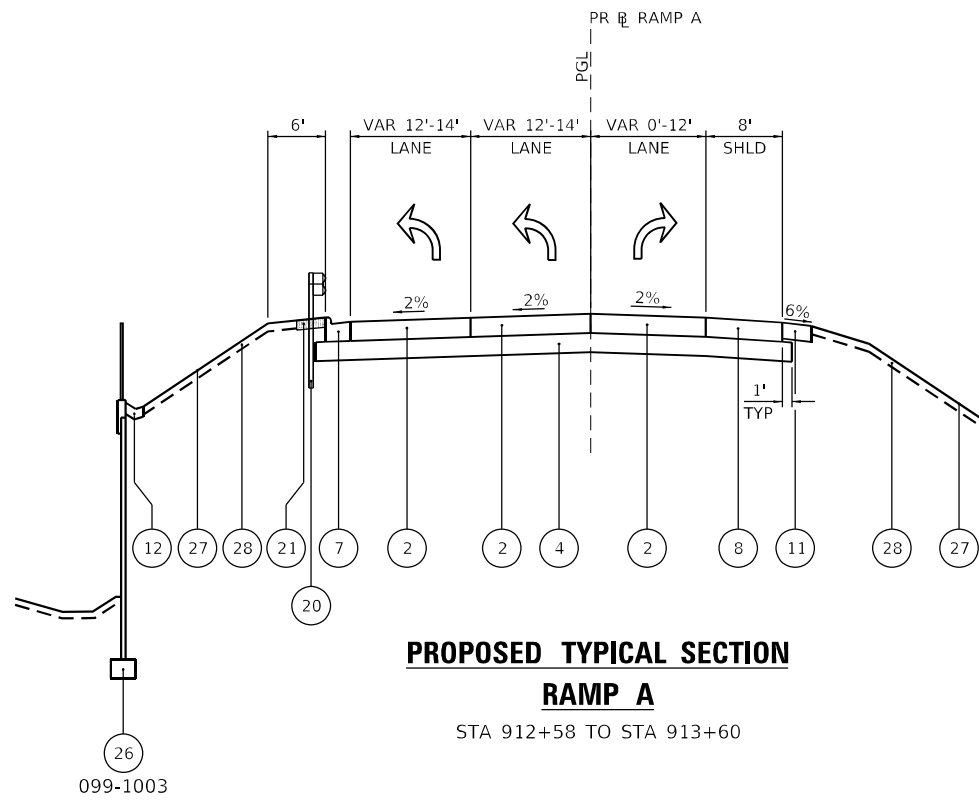

**PROPOSED TYPICAL SECTION  
RAMP A**

STA 912+58 TO STA 913+60

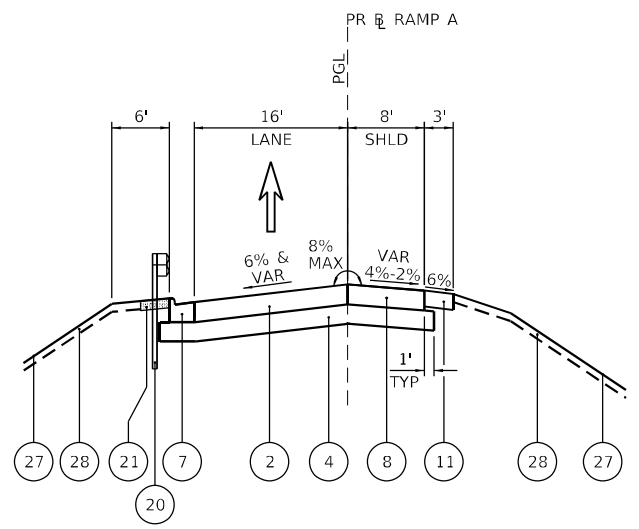

**PROPOSED TYPICAL SECTION  
RAMP A**

STA 907+85 TO STA 910+38

**LEGEND**

- 1 PORTLAND CEMENT CONCRETE PAVEMENT, 10" (JOINTED)
- 2 HOT-MIX ASPHALT PAVEMENT (FULL-DEPTH), 12.75"
- 3 HOT-MIX ASPHALT PAVEMENT (FULL-DEPTH), 10.25"
- 4 AGGREGATE SUBGRADE IMPROVEMENT, 12"
- 5 COMBINATION CONCRETE CURB AND GUTTER, TYPE B-6.24
- 6 COMBINATION CONCRETE CURB AND GUTTER, TYPE B-9.24
- 7 COMBINATION CONCRETE CURB AND GUTTER, TYPE M-4.24
- 8 HOT-MIX ASPHALT SHOULDERS, 12.75"
- 9 HOT-MIX ASPHALT PAVEMENT (FULL DEPTH), 9"
- 10 PORTLAND CEMENT CONCRETE SHOULDERS, 10"
- 11 AGGREGATE SHOULDERS, TYPE B 10"
- 12 TYPE B GUTTER
- 13 STAMPED COLORED PORTLAND CEMENT CONCRETE MEDIAN SURFACE, 6 INCH
- 14 CONCRETE MEDIAN, TYPE SB (SPECIAL)
- 15 CONCRETE MEDIAN SURFACE, 5 INCH
- 16 HOT-MIX ASPHALT SHARED-USE PATH (4")
- 17 PORTLAND CEMENT CONCRETE SIDEWALK 5 INCH
- 18 SUBBASE GRANULAR MATERIAL, TYPE B 6"
- 19 HOT-MIX ASPHALT PAVEMENT (FULL DEPTH), 15"
- 20 STEEL PLATE BEAM GUARDRAIL, TYPE A, 6 FOOT POSTS
- 21 HOT-MIX ASPHALT STABILIZATION 6" AT STEEL PLATE BEAM GUARD RAIL
- 22 CONCRETE BARRIER, SINGLE FACE, 44 INCH HEIGHT
- 23 HOT-MIX ASPHALT SURFACE COURSE, 1 1/2"
- 24 HOT-MIX ASPHALT SHOULDERS, 15"
- 25 HOT-MIX ASPHALT BINDER COURSE, 2 1/2"
- 26 RETAINING WALL (SEE STRUCTURAL PLANS)
- 27 SEEDING
- 28 TOPSOIL EXCAVATION AND PLACEMENT
- 29 PIPE UNDERDRAINS 6"
- 30 NOISE ABATEMENT WALL, GROUND MOUNTED

**NOTES**

1. AT ROADWAY LOCATIONS WITH CURB AND GUTTER, THE PROPOSED GUARDRAIL FACE SHALL ALIGN WITH THE BACK OF CURB.
2. SEE HOT-MIX ASPHALT MIXTURE REQUIREMENTS CHART FOR MIXTURE DESIGN.
3. CURB AND GUTTER WITH REVERSE PITCH GUTTER SHALL MATCH THE ADJACENT PAVEMENT LANE SLOPE.
4. SHARED-USE PATH SHALL BE COMPLIANT WITH THE AMERICANS WITH DISABILITIES ACT (ADA). FOR SHARED-USE PATH THE MAXIMUM RUNNING SLOPE IS 5%, MAXIMUM CROSS SLOPE IS 2%, AND MAXIMUM RAMP SLOPE IS 8.33%.
5. SIDE CURB ADJACENT TO PCC SHARED-USE PATH WILL BE MEASURED IN PLAN VIEW BY THE SQ FT AND PAID FOR AS PORTLAND CEMENT CONCRETE SIDEWALK, 5".
6. TRANSVERSE CONTRACTION JOINTS IN THE PCC SHARED-USE PATH SHALL BE SAWED NOT TOOLED.
7. THE AGGREGATE GRADATION FOR THE AGGREGATE SUBGRADE IMPROVEMENT 12" LOWER LIFT SHALL BE CS 1 OR RR 1.

MODEL: Default  
 FILE: M:\Benech\proj\benesch-pw\benesch.com\benesch\paw\107005\107140\_001\Eng\_Docs\_Phase\_1\Roadway\Typical\_Sections\1162H15-shi-typical-pr-rampA-01.dgn  
 D:\62H15-shi-typical-pr-rampA-01.dgn  
 5/12/24  
 2012/11/30



USER NAME = jworthington	DESIGNED - JREAMBILLO	REVISED -
PLOT SCALE = 240,0000' / ft.	DRAWN - SPOPOVICI	REVISED -
PLOT DATE = 2/7/2022	CHECKED - POBRIEN	REVISED -
	DATE - 02/04/2022	REVISED -

**STATE OF ILLINOIS  
DEPARTMENT OF TRANSPORTATION**

<b>PROPOSED TYPICAL SECTION RAMP A</b>	
SCALE: AS SHOWN	SHEET OF SHEETS
STA.	TO STA.

F.A./P.RTE.	SECTION	COUNTY	TOTAL SHEETS	SHEET NO.
*	2018-075-R	WILL	1510	55
CONTRACT NO. 62H15				
* FAI 55, FAP 338   ILLINOIS   FED. AID PROJECT				

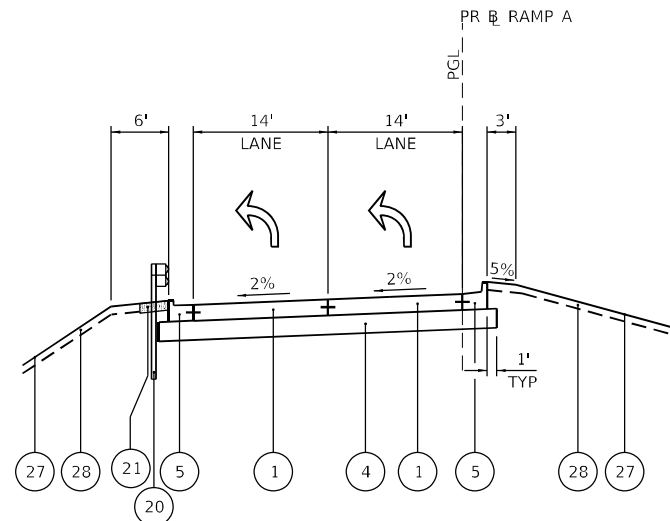

**PROPOSED TYPICAL SECTION  
RAMP A**

STA 913+60 TO STA 917+06

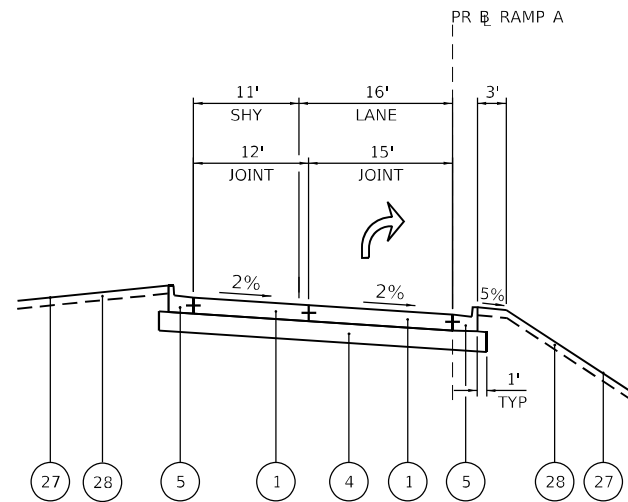

**PROPOSED TYPICAL SECTION  
RAMP A**

STA 1014+35 TO STA 1015+33

**LEGEND**

- 1 PORTLAND CEMENT CONCRETE PAVEMENT, 10" (JOINTED)
- 2 HOT-MIX ASPHALT PAVEMENT (FULL-DEPTH), 12.75"
- 3 HOT-MIX ASPHALT PAVEMENT (FULL-DEPTH), 10.25"
- 4 AGGREGATE SUBGRADE IMPROVEMENT, 12"
- 5 COMBINATION CONCRETE CURB AND GUTTER, TYPE B-6.24
- 6 COMBINATION CONCRETE CURB AND GUTTER, TYPE B-9.24
- 7 COMBINATION CONCRETE CURB AND GUTTER, TYPE M-4.24
- 8 HOT-MIX ASPHALT SHOULDERS, 12.75"
- 9 HOT-MIX ASPHALT PAVEMENT (FULL DEPTH), 9"
- 10 PORTLAND CEMENT CONCRETE SHOULDERS, 10"
- 11 AGGREGATE SHOULDERS, TYPE B 10"
- 12 TYPE B GUTTER
- 13 STAMPED COLORED PORTLAND CEMENT CONCRETE MEDIAN SURFACE, 6 INCH
- 14 CONCRETE MEDIAN, TYPE SB (SPECIAL)
- 15 CONCRETE MEDIAN SURFACE, 5 INCH
- 16 HOT-MIX ASPHALT SHARED-USE PATH (4")
- 17 PORTLAND CEMENT CONCRETE SIDEWALK 5 INCH
- 18 SUBBASE GRANULAR MATERIAL, TYPE B 6"
- 19 HOT-MIX ASPHALT PAVEMENT (FULL DEPTH), 15"
- 20 STEEL PLATE BEAM GUARDRAIL, TYPE A, 6 FOOT POSTS
- 21 HOT-MIX ASPHALT STABILIZATION 6" AT STEEL PLATE BEAM GUARD RAIL
- 22 CONCRETE BARRIER, SINGLE FACE, 44 INCH HEIGHT
- 23 HOT-MIX ASPHALT SURFACE COURSE, 1 1/2"
- 24 HOT-MIX ASPHALT SHOULDERS, 15"
- 25 HOT-MIX ASPHALT BINDER COURSE, 2 1/2"
- 26 RETAINING WALL (SEE STRUCTURAL PLANS)
- 27 SEEDING
- 28 TOPSOIL EXCAVATION AND PLACEMENT
- 29 PIPE UNDERDRAINS 6"
- 30 NOISE ABATEMENT WALL, GROUND MOUNTED

**NOTES**

1. AT ROADWAY LOCATIONS WITH CURB AND GUTTER, THE PROPOSED GUARDRAIL FACE SHALL ALIGN WITH THE BACK OF CURB.
2. SEE HOT-MIX ASPHALT MIXTURE REQUIREMENTS CHART FOR MIXTURE DESIGN.
3. CURB AND GUTTER WITH REVERSE PITCH GUTTER SHALL MATCH THE ADJACENT PAVEMENT LANE SLOPE.
4. SHARED-USE PATH SHALL BE COMPLIANT WITH THE AMERICANS WITH DISABILITIES ACT (ADA). FOR SHARED-USE PATH THE MAXIMUM RUNNING SLOPE IS 5%, MAXIMUM CROSS SLOPE IS 2%, AND MAXIMUM RAMP SLOPE IS 8.33%.
5. SIDE CURB ADJACENT TO PCC SHARED-USE PATH WILL BE MEASURED IN PLAN VIEW BY THE SQ FT AND PAID FOR AS PORTLAND CEMENT CONCRETE SIDEWALK, 5".
6. TRANSVERSE CONTRACTION JOINTS IN THE PCC SHARED-USE PATH SHALL BE SAWED NOT TOOLED.
7. THE AGGREGATE GRADATION FOR THE AGGREGATE SUBGRADE IMPROVEMENT 12" LOWER LIFT SHALL BE CS 1 OR RR 1.

MODEL: Default  
 FILE NAME: p:\benesch-pw\benesch-pw\benesch-pw\107005\107140\_001\Eng\_Docs\_Phase\_1\Roadway\Typical\_Sections\107140\_001\15-shi-typical-pr-ampA-07.dgn  
 D:\62H15-shi-typical-pr-ampA-07.dgn  
 51274  
 2012/11/30



USER NAME = jworthington	DESIGNED - JREAMBILLO	REVISED -
PLOT SCALE = 240,0000 ' / ft.	DRAWN - SPOPOVICI	REVISED -
PLOT DATE = 2/7/2022	CHECKED - POBRIEN	REVISED -
	DATE - 02/04/2022	REVISED -

**STATE OF ILLINOIS  
DEPARTMENT OF TRANSPORTATION**

**PROPOSED TYPICAL SECTION  
RAMP A**

SCALE: AS SHOWN SHEET OF SHEETS STA. TO STA.

F.A./P.RTE.	SECTION	COUNTY	TOTAL SHEETS	SHEET NO.
*	2018-075-R	WILL	1510	56
CONTRACT NO. 62H15				
* FAI 55, FAP 338 ILLINOIS FED. AID PROJECT				



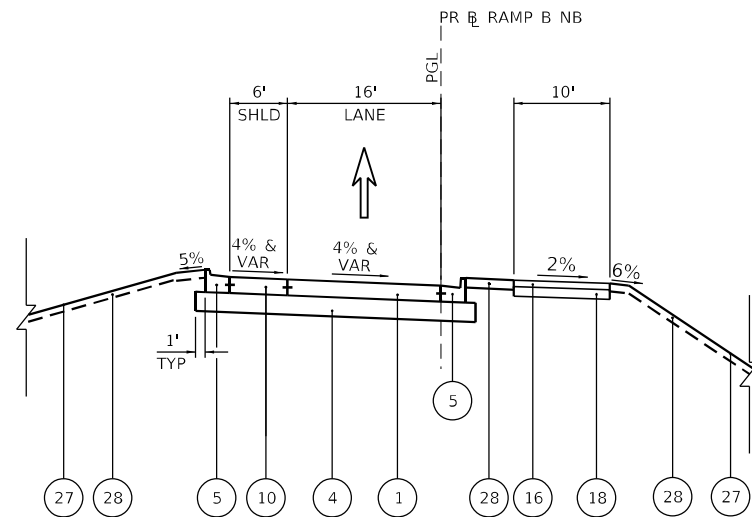

**PROPOSED TYPICAL SECTION**

**RAMP B**

STA 1107+00 TO STA 1108+00

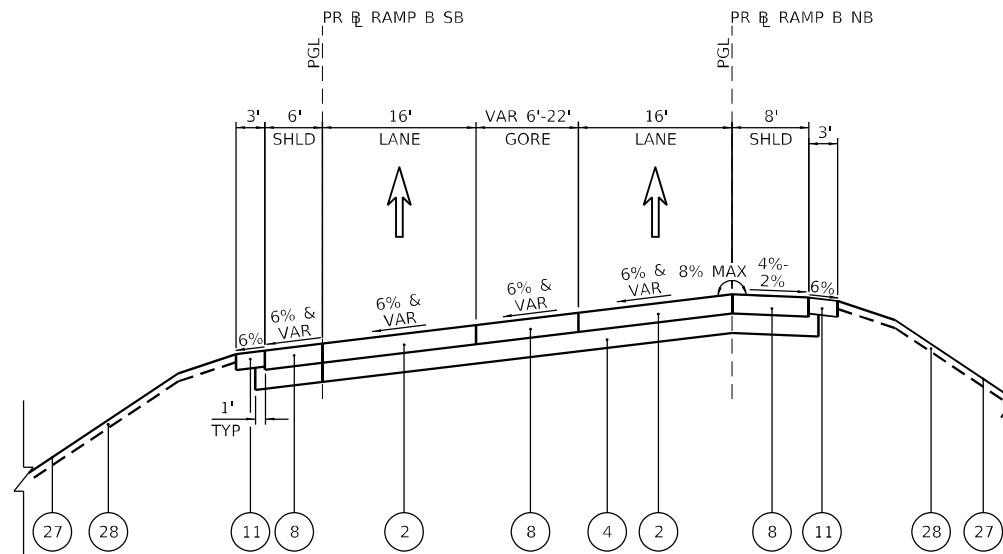

**PROPOSED TYPICAL SECTION**

**RAMP B**

STA 1109+56 TO STA 1112+65

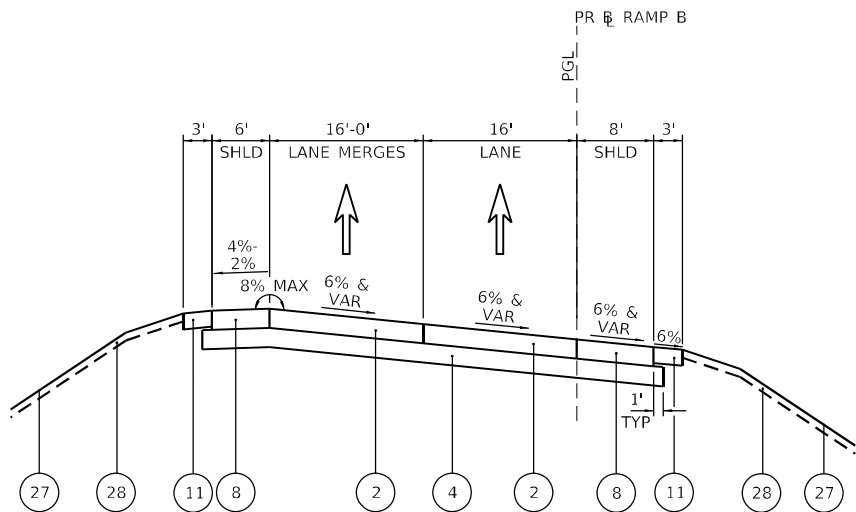

**PROPOSED TYPICAL SECTION**

**RAMP B**

STA 1112+65 TO STA 1119+00

**LEGEND**

- 1 PORTLAND CEMENT CONCRETE PAVEMENT, 10" (JOINTED)
- 2 HOT-MIX ASPHALT PAVEMENT (FULL-DEPTH), 12.75"
- 3 HOT-MIX ASPHALT PAVEMENT (FULL-DEPTH), 10.25"
- 4 AGGREGATE SUBGRADE IMPROVEMENT, 12"
- 5 COMBINATION CONCRETE CURB AND GUTTER, TYPE B-6.24
- 6 COMBINATION CONCRETE CURB AND GUTTER, TYPE B-9.24
- 7 COMBINATION CONCRETE CURB AND GUTTER, TYPE M-4.24
- 8 HOT-MIX ASPHALT SHOULDERS, 12.75"
- 9 HOT-MIX ASPHALT PAVEMENT (FULL DEPTH), 9"
- 10 PORTLAND CEMENT CONCRETE SHOULDERS, 10"
- 11 AGGREGATE SHOULDERS, TYPE B 10"
- 12 TYPE B GUTTER
- 13 STAMPED COLORED PORTLAND CEMENT CONCRETE MEDIAN SURFACE, 6 INCH
- 14 CONCRETE MEDIAN, TYPE SB (SPECIAL)
- 15 CONCRETE MEDIAN SURFACE, 5 INCH
- 16 HOT-MIX ASPHALT SHARED-USE PATH (4")
- 17 PORTLAND CEMENT CONCRETE SIDEWALK 5 INCH
- 18 SUBBASE GRANULAR MATERIAL, TYPE B 6"
- 19 HOT-MIX ASPHALT PAVEMENT (FULL DEPTH), 15"
- 20 STEEL PLATE BEAM GUARDRAIL, TYPE A, 6 FOOT POSTS
- 21 HOT-MIX ASPHALT STABILIZATION 6" AT STEEL PLATE BEAM GUARD RAIL
- 22 CONCRETE BARRIER, SINGLE FACE, 44 INCH HEIGHT
- 23 HOT-MIX ASPHALT SURFACE COURSE, 1 1/2"
- 24 HOT-MIX ASPHALT SHOULDERS, 15"
- 25 HOT-MIX ASPHALT BINDER COURSE, 2 1/2"
- 26 RETAINING WALL (SEE STRUCTURAL PLANS)
- 27 SEEDING
- 28 TOPSOIL EXCAVATION AND PLACEMENT
- 29 PIPE UNDERDRAINS 6"
- 30 NOISE ABATEMENT WALL, GROUND MOUNTED

**NOTES**

1. AT ROADWAY LOCATIONS WITH CURB AND GUTTER, THE PROPOSED GUARDRAIL FACE SHALL ALIGN WITH THE BACK OF CURB.
2. SEE HOT-MIX ASPHALT MIXTURE REQUIREMENTS CHART FOR MIXTURE DESIGN.
3. CURB AND GUTTER WITH REVERSE PITCH GUTTER SHALL MATCH THE ADJACENT PAVEMENT LANE SLOPE.
4. SHARED-USE PATH SHALL BE COMPLIANT WITH THE AMERICANS WITH DISABILITIES ACT (ADA). FOR SHARED-USE PATH THE MAXIMUM RUNNING SLOPE IS 5%, MAXIMUM CROSS SLOPE IS 2%, AND MAXIMUM RAMP SLOPE IS 8.33%.
5. SIDE CURB ADJACENT TO PCC SHARED-USE PATH WILL BE MEASURED IN PLAN VIEW BY THE SQ FT AND PAID FOR AS PORTLAND CEMENT CONCRETE SIDEWALK, 5".
6. TRANSVERSE CONTRACTION JOINTS IN THE PCC SHARED-USE PATH SHALL BE SAWED NOT TOOLED.
7. THE AGGREGATE GRADATION FOR THE AGGREGATE SUBGRADE IMPROVEMENT 12" LOWER LIFT SHALL BE CS 1 OR RR 1.

MODEL: Default  
 FILE: Name: pr-benech-pw-benech-pw-benech-pw-01 Documents\110705\110740\001\Eng\_Docs\_Phase 110705\110740\001\Eng\_Docs\_Phase 110705\110740\001\Typical Sections\110740\115-shl-typical-rampB-01.dgn  
 2012/11/30

USER NAME = jworthington	DESIGNED - JREAMBILLO	REVISED -
DRAWN - SPOPOVICI	REVISED -	
PLOT SCALE = 240,0000 ' / ft.	CHECKED - POBRIEN	REVISED -
PLOT DATE = 2/7/2022	DATE - 02/04/2022	REVISED -

**STATE OF ILLINOIS  
DEPARTMENT OF TRANSPORTATION**

PROPOSED TYPICAL SECTION			
RAMP B			
SCALE: AS SHOWN	SHEET	OF	SHEETS
STA.		TO	STA.

F.A./P RTE.	SECTION	COUNTY	TOTAL SHEETS	SHEET NO.
-	2018-075-R	WILL	1510	57
CONTRACT NO. 62H15				
FAI 55, FAP 338 ILLINOIS FED. AID PROJECT				

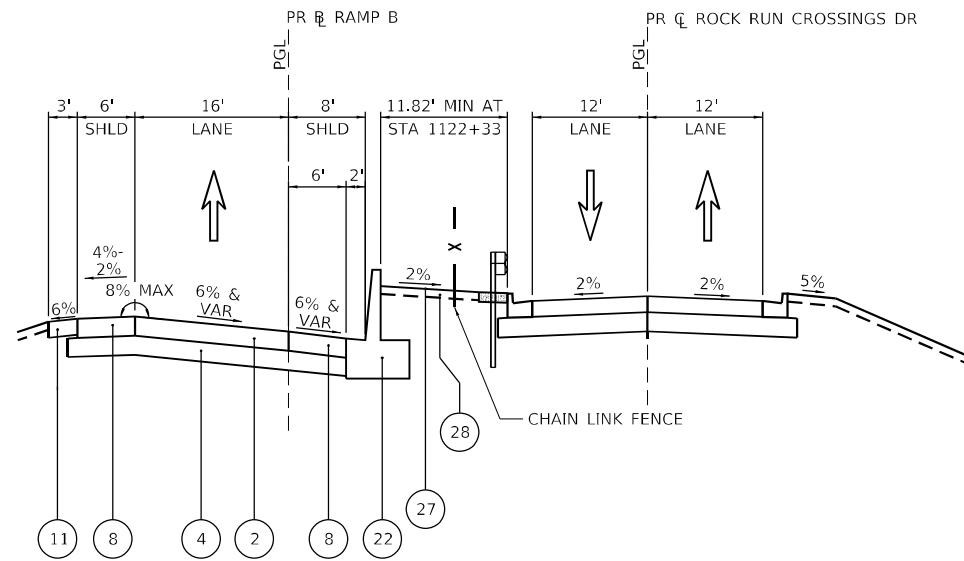

**PROPOSED TYPICAL SECTION**

**RAMP B**

STA 1120+00 TO STA 1124+80

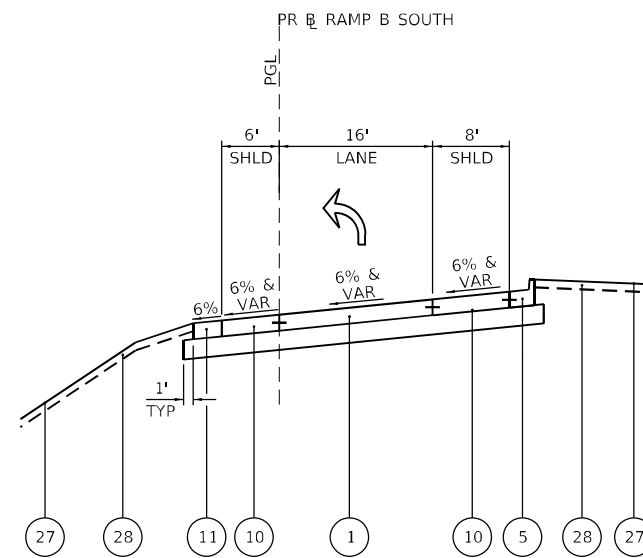

**PROPOSED TYPICAL SECTION**

**RAMP B**

STA 1202+70 TO STA 1205+20

**LEGEND**

- 1 PORTLAND CEMENT CONCRETE PAVEMENT, 10" (JOINTED)
- 2 HOT-MIX ASPHALT PAVEMENT (FULL-DEPTH), 12.75"
- 3 HOT-MIX ASPHALT PAVEMENT (FULL-DEPTH), 10.25"
- 4 AGGREGATE SUBGRADE IMPROVEMENT, 12"
- 5 COMBINATION CONCRETE CURB AND GUTTER, TYPE B-6.24
- 6 COMBINATION CONCRETE CURB AND GUTTER, TYPE B-9.24
- 7 COMBINATION CONCRETE CURB AND GUTTER, TYPE M-4.24
- 8 HOT-MIX ASPHALT SHOULDERS, 12.75"
- 9 HOT-MIX ASPHALT PAVEMENT (FULL DEPTH), 9"
- 10 PORTLAND CEMENT CONCRETE SHOULDERS, 10"
- 11 AGGREGATE SHOULDERS, TYPE B 10"
- 12 TYPE B GUTTER
- 13 STAMPED COLORED PORTLAND CEMENT CONCRETE MEDIAN SURFACE, 6 INCH
- 14 CONCRETE MEDIAN, TYPE SB (SPECIAL)
- 15 CONCRETE MEDIAN SURFACE, 5 INCH
- 16 HOT-MIX ASPHALT SHARED-USE PATH (4")
- 17 PORTLAND CEMENT CONCRETE SIDEWALK 5 INCH
- 18 SUBBASE GRANULAR MATERIAL, TYPE B 6"
- 19 HOT-MIX ASPHALT PAVEMENT (FULL DEPTH), 15"
- 20 STEEL PLATE BEAM GUARDRAIL, TYPE A, 6 FOOT POSTS
- 21 HOT-MIX ASPHALT STABILIZATION 6" AT STEEL PLATE BEAM GUARD RAIL
- 22 CONCRETE BARRIER, SINGLE FACE, 44 INCH HEIGHT
- 23 HOT-MIX ASPHALT SURFACE COURSE, 1 1/2"
- 24 HOT-MIX ASPHALT SHOULDERS, 15"
- 25 HOT-MIX ASPHALT BINDER COURSE, 2 1/2"
- 26 RETAINING WALL (SEE STRUCTURAL PLANS)
- 27 SEEDING
- 28 TOPSOIL EXCAVATION AND PLACEMENT
- 29 PIPE UNDERDRAINS 6"
- 30 NOISE ABATEMENT WALL, GROUND MOUNTED

**NOTES**

1. AT ROADWAY LOCATIONS WITH CURB AND GUTTER, THE PROPOSED GUARDRAIL FACE SHALL ALIGN WITH THE BACK OF CURB.
2. SEE HOT-MIX ASPHALT MIXTURE REQUIREMENTS CHART FOR MIXTURE DESIGN.
3. CURB AND GUTTER WITH REVERSE PITCH GUTTER SHALL MATCH THE ADJACENT PAVEMENT LANE SLOPE.
4. SHARED-USE PATH SHALL BE COMPLIANT WITH THE AMERICANS WITH DISABILITIES ACT (ADA). FOR SHARED-USE PATH THE MAXIMUM RUNNING SLOPE IS 5%, MAXIMUM CROSS SLOPE IS 2%, AND MAXIMUM RAMP SLOPE IS 8.33%.
5. SIDE CURB ADJACENT TO PCC SHARED-USE PATH WILL BE MEASURED IN PLAN VIEW BY THE SQ FT AND PAID FOR AS PORTLAND CEMENT CONCRETE SIDEWALK, 5".
6. TRANSVERSE CONTRACTION JOINTS IN THE PCC SHARED-USE PATH SHALL BE SAWED NOT TOOLED.
7. THE AGGREGATE GRADATION FOR THE AGGREGATE SUBGRADE IMPROVEMENT 12" LOWER LIFT SHALL BE CS 1 OR RR 1.

MODEL: Default  
 FILE NAME: p:\benesch-pw\benesch-pw\benesch-pw\01\Documents\11\10705\107140\_001\Eng\_Docs\_Phase\_11\Roadway\Typical\_Sections\1162\115-shi-typical-pr-rampB-07.dgn  
 D:\62H15-shi-typical-pr-rampB-07.dgn  
 51274  
 2012/11/30



USER NAME = jworthington	DESIGNED - JREAMBILLO	REVISED -
	DRAWN - SPOPOVICI	REVISED -
PLOT SCALE = 240,0000' / ft.	CHECKED - POBRIEN	REVISED -
PLOT DATE = 2/7/2022	DATE - 02/04/2022	REVISED -

**STATE OF ILLINOIS  
DEPARTMENT OF TRANSPORTATION**

**PROPOSED TYPICAL SECTIONS  
RAMP B**

SCALE: AS SHOWN SHEET OF SHEETS STA. TO STA.

F.A./P.RTE.	SECTION	COUNTY	TOTAL SHEETS	SHEET NO.
*	2018-075-R	WILL	1510	58
CONTRACT NO. 62H15				
* FAI 55, FAP 338 ILLINOIS FED. AID PROJECT				

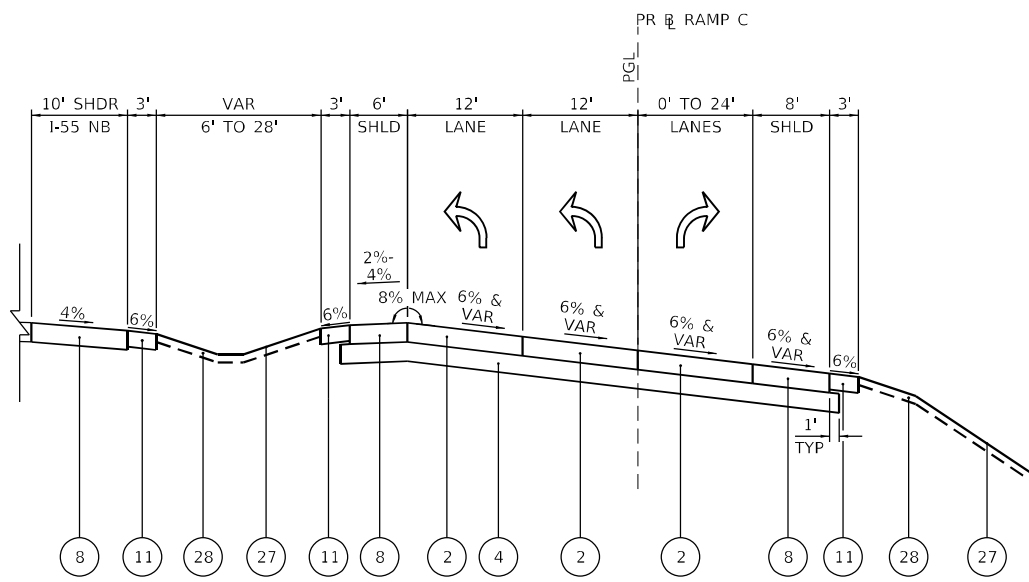

**PROPOSED TYPICAL SECTION  
RAMP C**  
STA 806+50 TO STA 808+45

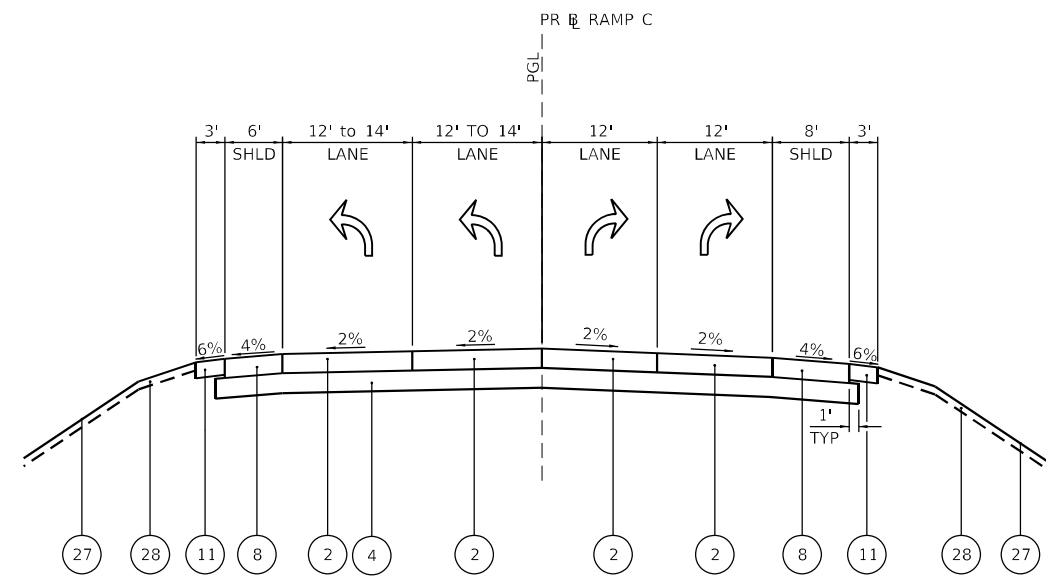

**PROPOSED TYPICAL SECTION  
RAMP C**  
STA 808+45 TO STA 810+51

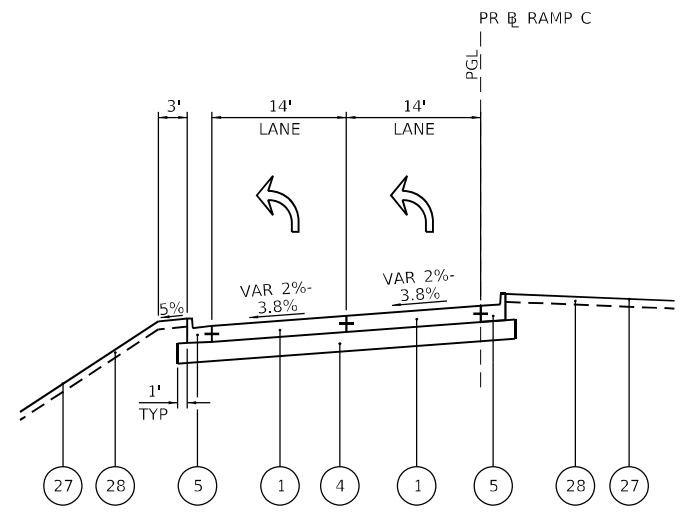

**PROPOSED TYPICAL SECTION  
RAMP C**  
STA 811+80 TO STA 815+54

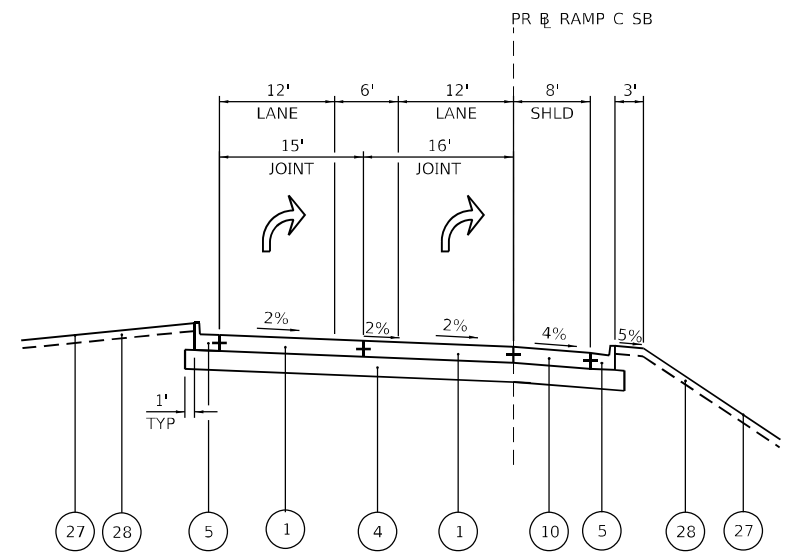

**PROPOSED TYPICAL SECTION  
RAMP C**  
STA 706+20 TO STA 706+91

- LEGEND**
- 1 PORTLAND CEMENT CONCRETE PAVEMENT, 10" (JOINTED)
  - 2 HOT-MIX ASPHALT PAVEMENT (FULL-DEPTH), 12.75"
  - 3 HOT-MIX ASPHALT PAVEMENT (FULL-DEPTH), 10.25"
  - 4 AGGREGATE SUBGRADE IMPROVEMENT, 12"
  - 5 COMBINATION CONCRETE CURB AND GUTTER, TYPE B-6.24
  - 6 COMBINATION CONCRETE CURB AND GUTTER, TYPE B-9.24
  - 7 COMBINATION CONCRETE CURB AND GUTTER, TYPE M-4.24
  - 8 HOT-MIX ASPHALT SHOULDERS, 12.75"
  - 9 HOT-MIX ASPHALT PAVEMENT (FULL DEPTH), 9"
  - 10 PORTLAND CEMENT CONCRETE SHOULDERS, 10"
  - 11 AGGREGATE SHOULDERS, TYPE B 10"
  - 12 TYPE B GUTTER
  - 13 STAMPED COLORED PORTLAND CEMENT CONCRETE MEDIAN SURFACE, 6 INCH
  - 14 CONCRETE MEDIAN, TYPE SB (SPECIAL)
  - 15 CONCRETE MEDIAN SURFACE, 5 INCH
  - 16 HOT-MIX ASPHALT SHARED-USE PATH (4")
  - 17 PORTLAND CEMENT CONCRETE SIDEWALK 5 INCH
  - 18 SUBBASE GRANULAR MATERIAL, TYPE B 6"
  - 19 HOT-MIX ASPHALT PAVEMENT (FULL DEPTH), 15"
  - 20 STEEL PLATE BEAM GUARDRAIL, TYPE A, 6 FOOT POSTS
  - 21 HOT-MIX ASPHALT STABILIZATION 6" AT STEEL PLATE BEAM GUARD RAIL
  - 22 CONCRETE BARRIER, SINGLE FACE, 44 INCH HEIGHT
  - 23 HOT-MIX ASPHALT SURFACE COURSE, 1 1/2"
  - 24 HOT-MIX ASPHALT SHOULDERS, 15"
  - 25 HOT-MIX ASPHALT BINDER COURSE, 2 1/2"
  - 26 RETAINING WALL (SEE STRUCTURAL PLANS)
  - 27 SEEDING
  - 28 TOPSOIL EXCAVATION AND PLACEMENT
  - 29 PIPE UNDERDRAINS 6"
  - 30 NOISE ABATEMENT WALL, GROUND MOUNTED

- NOTES**
1. AT ROADWAY LOCATIONS WITH CURB AND GUTTER, THE PROPOSED GUARDRAIL FACE SHALL ALIGN WITH THE BACK OF CURB.
  2. SEE HOT-MIX ASPHALT MIXTURE REQUIREMENTS CHART FOR MIXTURE DESIGN.
  3. CURB AND GUTTER WITH REVERSE PITCH GUTTER SHALL MATCH THE ADJACENT PAVEMENT LANE SLOPE.
  4. SHARED-USE PATH SHALL BE COMPLIANT WITH THE AMERICANS WITH DISABILITIES ACT (ADA). FOR SHARED-USE PATH THE MAXIMUM RUNNING SLOPE IS 5%, MAXIMUM CROSS SLOPE IS 2%, AND MAXIMUM RAMP SLOPE IS 8.33%.
  5. SIDE CURB ADJACENT TO PCC SHARED-USE PATH WILL BE MEASURED IN PLAN VIEW BY THE SQ FT AND PAID FOR AS PORTLAND CEMENT CONCRETE SIDEWALK, 5".
  6. TRANSVERSE CONTRACTION JOINTS IN THE PCC SHARED-USE PATH SHALL BE SAWED NOT TOOLED.
  7. THE AGGREGATE GRADATION FOR THE AGGREGATE SUBGRADE IMPROVEMENT 12" LOWER LIFT SHALL BE CS 1 OR RR 1.

MODEL: Default  
 FILE: M:\MFC\_Plan\benesch-plan\benesch-plan\Roadway\Typical Sections\107005\107040\_001\Eng\_Docs\_Phase\_1\Roadway\Typical Sections\107005\107040\_001\15-shr-typical-rampC-01.dgn  
 D:\62H15-shr-typical-pr-rampC-01.dgn  
 51274  
 2012/11/30



USER NAME = jworthington	DESIGNED - JREAMBILLO	REVISED -
PLOT SCALE = 240,0000' / ft.	DRAWN - SPOPOVICI	REVISED -
PLOT DATE = 2/7/2022	CHECKED - POBRIEN	REVISED -
	DATE - 02/04/2022	REVISED -

**STATE OF ILLINOIS  
DEPARTMENT OF TRANSPORTATION**

PROPOSED TYPICAL SECTIONS RAMP C			
SCALE: AS SHOWN	SHEET	OF	SHEETS
STA.		TO	STA.

F.A./P.RTE.	SECTION	COUNTY	TOTAL SHEETS	SHEET NO.
*	2018-075-R	WILL	1510	59
CONTRACT NO. 62H15				
* FAI 55, FAP 338 ILLINOIS FED. AID PROJECT				

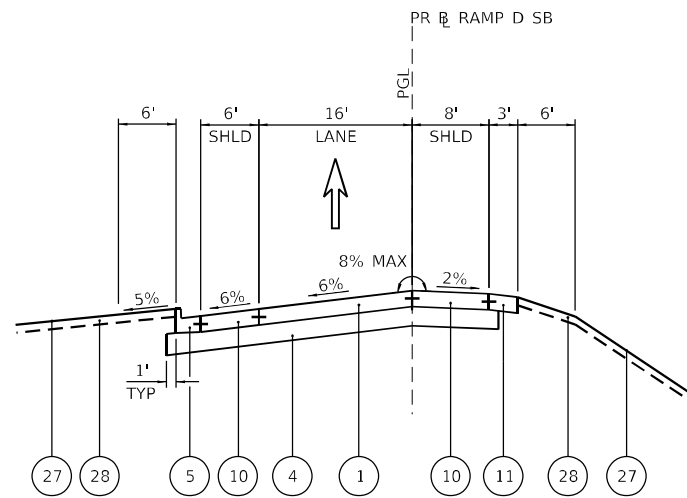

**PROPOSED TYPICAL SECTION**  
**RAMP D**  
 STA 404+47 TO STA 412+88

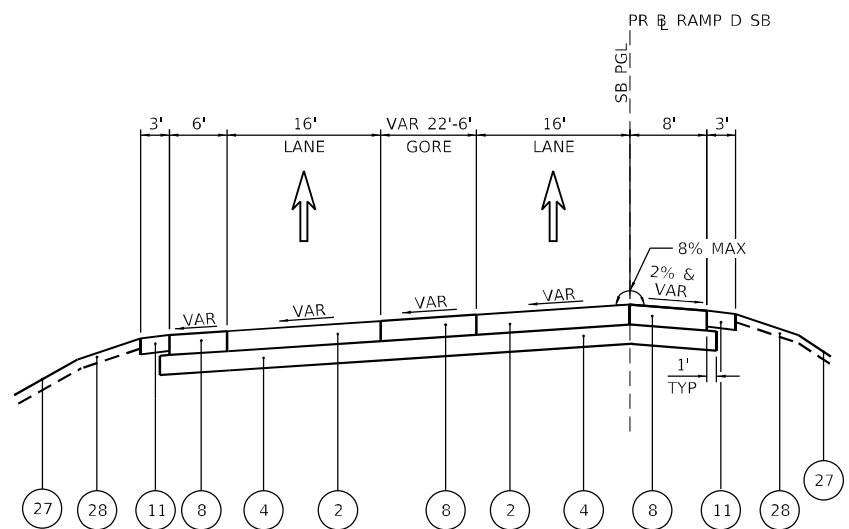

**PROPOSED TYPICAL SECTION**  
**RAMP D**  
 STA 412+88 TO STA 413+90

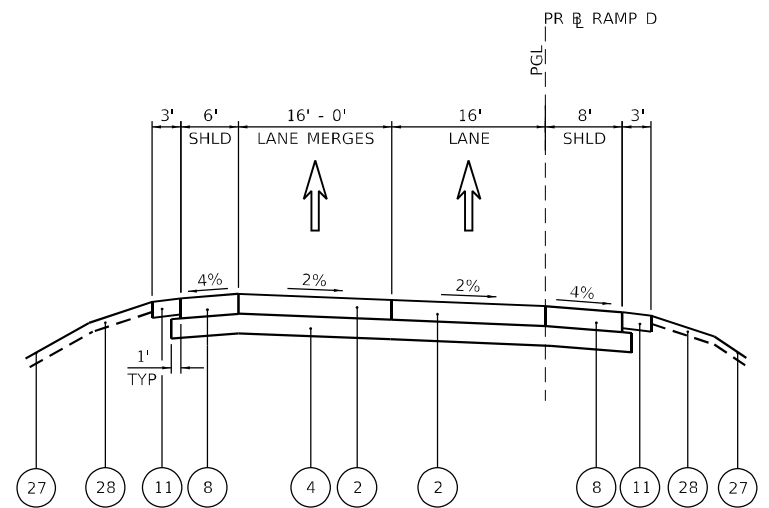

**PROPOSED TYPICAL SECTION**  
**RAMP D**  
 STA 415+70 TO STA 421+51

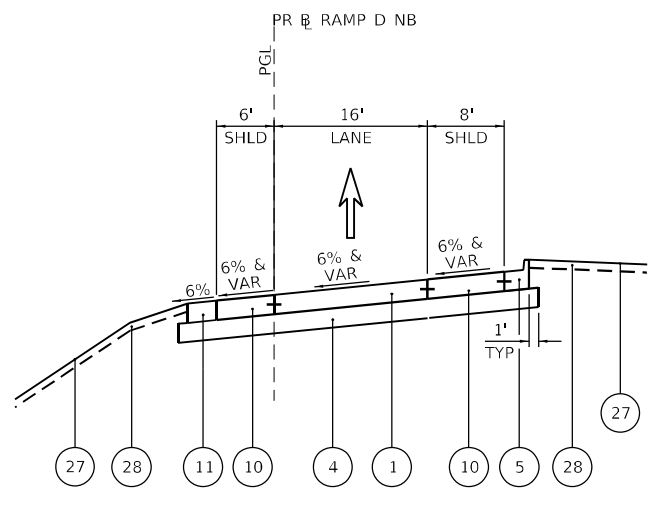

**PROPOSED TYPICAL SECTION**  
**RAMP D**  
 STA 603+97 TO STA 609+67

- LEGEND**
- 1 PORTLAND CEMENT CONCRETE PAVEMENT, 10" (JOINTED)
  - 2 HOT-MIX ASPHALT PAVEMENT (FULL-DEPTH), 12.75"
  - 3 HOT-MIX ASPHALT PAVEMENT (FULL-DEPTH), 10.25"
  - 4 AGGREGATE SUBGRADE IMPROVEMENT, 12"
  - 5 COMBINATION CONCRETE CURB AND GUTTER, TYPE B-6.24
  - 6 COMBINATION CONCRETE CURB AND GUTTER, TYPE B-9.24
  - 7 COMBINATION CONCRETE CURB AND GUTTER, TYPE M-4.24
  - 8 HOT-MIX ASPHALT SHOULDERS, 12.75"
  - 9 HOT-MIX ASPHALT PAVEMENT (FULL DEPTH), 9"
  - 10 PORTLAND CEMENT CONCRETE SHOULDERS, 10"
  - 11 AGGREGATE SHOULDERS, TYPE B 10"
  - 12 TYPE B GUTTER
  - 13 STAMPED COLORED PORTLAND CEMENT CONCRETE MEDIAN SURFACE, 6 INCH
  - 14 CONCRETE MEDIAN, TYPE SB (SPECIAL)
  - 15 CONCRETE MEDIAN SURFACE, 5 INCH
  - 16 HOT-MIX ASPHALT SHARED-USE PATH (4")
  - 17 PORTLAND CEMENT CONCRETE SIDEWALK 5 INCH
  - 18 SUBBASE GRANULAR MATERIAL, TYPE B 6"
  - 19 HOT-MIX ASPHALT PAVEMENT (FULL DEPTH), 15"
  - 20 STEEL PLATE BEAM GUARDRAIL, TYPE A, 6 FOOT POSTS
  - 21 HOT-MIX ASPHALT STABILIZATION 6" AT STEEL PLATE BEAM GUARD RAIL
  - 22 CONCRETE BARRIER, SINGLE FACE, 44 INCH HEIGHT
  - 23 HOT-MIX ASPHALT SURFACE COURSE, 1 1/2"
  - 24 HOT-MIX ASPHALT SHOULDERS, 15"
  - 25 HOT-MIX ASPHALT BINDER COURSE, 2 1/2"
  - 26 RETAINING WALL (SEE STRUCTURAL PLANS)
  - 27 SEEDING
  - 28 TOPSOIL EXCAVATION AND PLACEMENT
  - 29 PIPE UNDERDRAINS 6"
  - 30 NOISE ABATEMENT WALL, GROUND MOUNTED

- NOTES**
1. AT ROADWAY LOCATIONS WITH CURB AND GUTTER, THE PROPOSED GUARDRAIL FACE SHALL ALIGN WITH THE BACK OF CURB.
  2. SEE HOT-MIX ASPHALT MIXTURE REQUIREMENTS CHART FOR MIXTURE DESIGN.
  3. CURB AND GUTTER WITH REVERSE PITCH GUTTER SHALL MATCH THE ADJACENT PAVEMENT LANE SLOPE.
  4. SHARED-USE PATH SHALL BE COMPLIANT WITH THE AMERICANS WITH DISABILITIES ACT (ADA). FOR SHARED-USE PATH THE MAXIMUM RUNNING SLOPE IS 5%, MAXIMUM CROSS SLOPE IS 2%, AND MAXIMUM RAMP SLOPE IS 8.33%.
  5. SIDE CURB ADJACENT TO PCC SHARED-USE PATH WILL BE MEASURED IN PLAN VIEW BY THE SQ FT AND PAID FOR AS PORTLAND CEMENT CONCRETE SIDEWALK, 5".
  6. TRANSVERSE CONTRACTION JOINTS IN THE PCC SHARED-USE PATH SHALL BE SAWED NOT TOOLED.
  7. THE AGGREGATE GRADATION FOR THE AGGREGATE SUBGRADE IMPROVEMENT 12" LOWER LIFT SHALL BE CS 1 OR RR 1.

MODEL: Default  
 FILE: M:\MFC\_Plan\benesch-pw-bentley.com\benesch-pw-01\Documents\107005\107140\_001\Eng\_Docs\_Phase\_1\Roadway\Typical Sections\162H15-sh-typical-pr-rampD-01.dgn  
 D:\62H15-sh-typical-pr-rampD-01.dgn  
 51274  
 2012/11/30



USER NAME = jworthington	DESIGNED - JREAMBILLO	REVISED -
	DRAWN - SPOPOVICI	REVISED -
PLOT SCALE = 240,0000' / ft.	CHECKED - POBRIEN	REVISED -
PLOT DATE = 2/7/2022	DATE - 02/04/2022	REVISED -

**STATE OF ILLINOIS  
 DEPARTMENT OF TRANSPORTATION**

<b>PROPOSED TYPICAL SECTION</b>	
<b>RAMP D</b>	
SCALE: AS SHOWN	SHEET OF SHEETS
STA.	TO STA.

F.A./P.RTE.	SECTION	COUNTY	TOTAL SHEETS	SHEET NO.
	2018-075-R	WILL	1510	60
CONTRACT NO. 62H15				
* FAI 55, FAP 338 ILLINOIS FED. AID PROJECT				

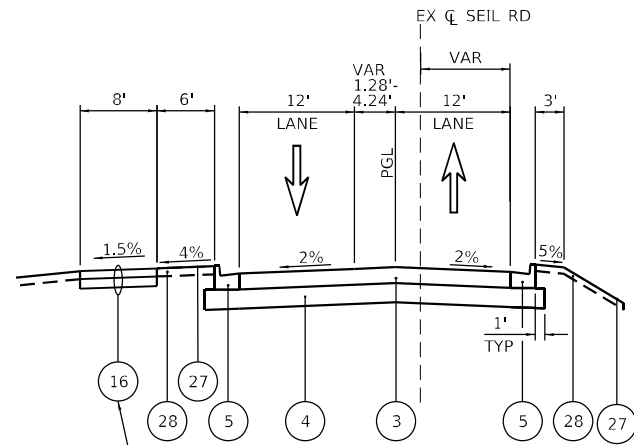

**PROPOSED TYPICAL SECTION  
SEIL RD**

STA 4003+90 TO STA 4007+18

NOTE: NO GEOMETRY WITHIN THIS ROADWAY SECTION IS PARALLEL TO THE EXISTING SEIL ROAD CENTERLINE.

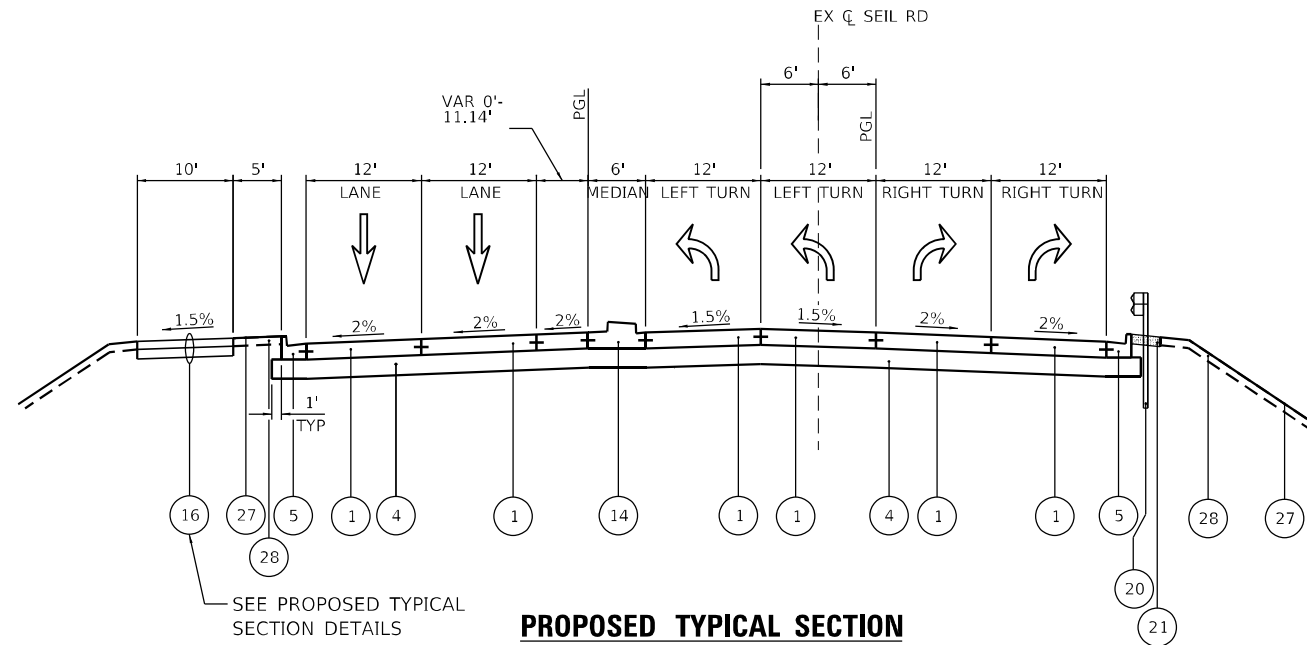

**PROPOSED TYPICAL SECTION  
SEIL RD**

STA 4016+17 TO STA 4017+84

NOTE: ALL EB LANES AND RAISED MEDIAN WITHIN THIS ROADWAY SECTION IS PARALLEL TO THE EXISTING SEIL ROAD CENTERLINE.

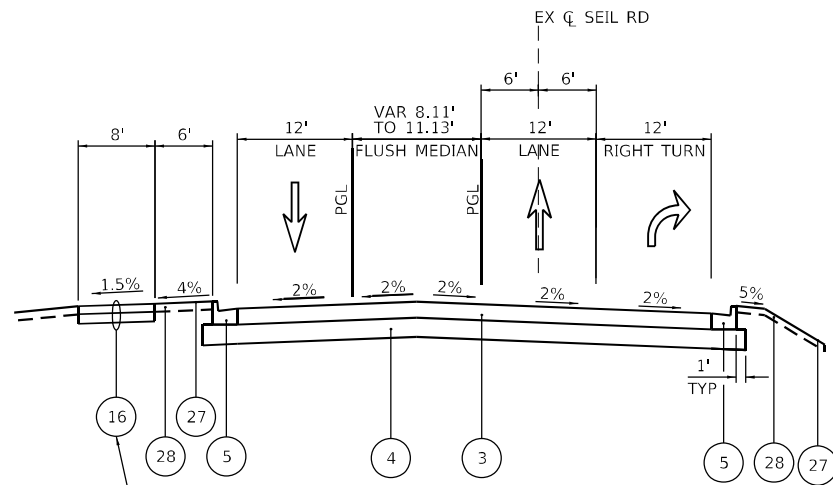

**PROPOSED TYPICAL SECTION  
SEIL RD**

STA 4008+53 TO STA 4009+59

NOTE: EB THRU AND RIGHT TURN LANE WITHIN THIS ROADWAY SECTION IS PARALLEL TO THE EXISTING SEIL ROAD CENTERLINE.

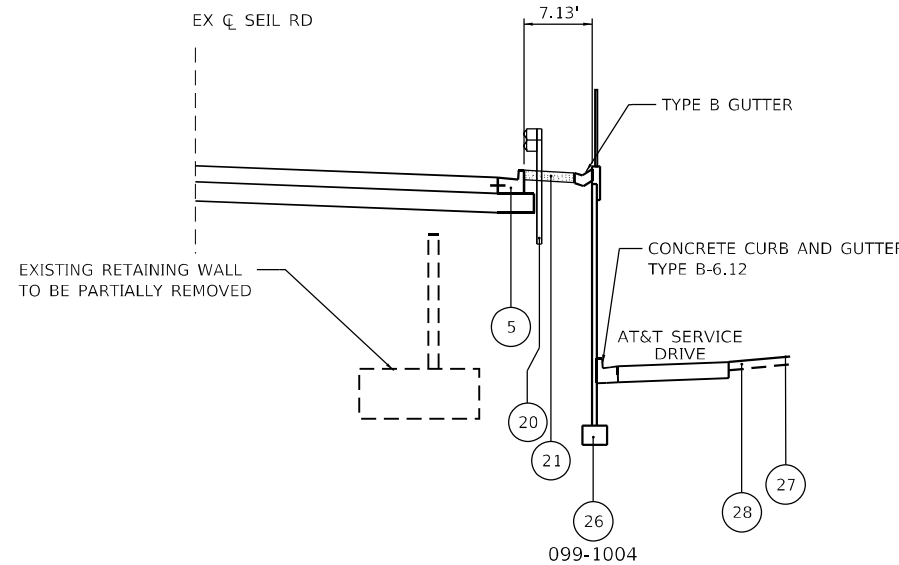

**PROPOSED TYPICAL SECTION  
SEIL RD**

STA 4014+49 TO STA 4015+80

**LEGEND**

- 1 PORTLAND CEMENT CONCRETE PAVEMENT, 10" (JOINTED)
- 2 HOT-MIX ASPHALT PAVEMENT (FULL-DEPTH), 12.75"
- 3 HOT-MIX ASPHALT PAVEMENT (FULL-DEPTH), 10.25"
- 4 AGGREGATE SUBGRADE IMPROVEMENT, 12"
- 5 COMBINATION CONCRETE CURB AND GUTTER, TYPE B-6.24
- 6 COMBINATION CONCRETE CURB AND GUTTER, TYPE B-9.24
- 7 COMBINATION CONCRETE CURB AND GUTTER, TYPE M-4.24
- 8 HOT-MIX ASPHALT SHOULDERS, 12.75"
- 9 HOT-MIX ASPHALT PAVEMENT (FULL DEPTH), 9"
- 10 PORTLAND CEMENT CONCRETE SHOULDERS, 10"
- 11 AGGREGATE SHOULDERS, TYPE B 10"
- 12 TYPE B GUTTER
- 13 STAMPED COLORED PORTLAND CEMENT CONCRETE MEDIAN SURFACE, 6 INCH
- 14 CONCRETE MEDIAN, TYPE SB (SPECIAL)
- 15 CONCRETE MEDIAN SURFACE, 5 INCH
- 16 HOT-MIX ASPHALT SHARED-USE PATH (4")
- 17 PORTLAND CEMENT CONCRETE SIDEWALK 5 INCH
- 18 SUBBASE GRANULAR MATERIAL, TYPE B 6"
- 19 HOT-MIX ASPHALT PAVEMENT (FULL DEPTH), 15"
- 20 STEEL PLATE BEAM GUARDRAIL, TYPE A, 6 FOOT POSTS
- 21 HOT-MIX ASPHALT STABILIZATION 6" AT STEEL PLATE BEAM GUARD RAIL
- 22 CONCRETE BARRIER, SINGLE FACE, 44 INCH HEIGHT
- 23 HOT-MIX ASPHALT SURFACE COURSE, 1 1/2"
- 24 HOT-MIX ASPHALT SHOULDERS, 15"
- 25 HOT-MIX ASPHALT BINDER COURSE, 2 1/2"
- 26 RETAINING WALL (SEE STRUCTURAL PLANS)
- 27 SEEDING
- 28 TOPSOIL EXCAVATION AND PLACEMENT
- 29 PIPE UNDERDRAINS 6"
- 30 NOISE ABATEMENT WALL, GROUND MOUNTED

**NOTES**

1. AT ROADWAY LOCATIONS WITH CURB AND GUTTER, THE PROPOSED GUARDRAIL FACE SHALL ALIGN WITH THE BACK OF CURB.
2. SEE HOT-MIX ASPHALT MIXTURE REQUIREMENTS CHART FOR MIXTURE DESIGN.
3. CURB AND GUTTER WITH REVERSE PITCH GUTTER SHALL MATCH THE ADJACENT PAVEMENT LANE SLOPE.
4. SHARED-USE PATH SHALL BE COMPLIANT WITH THE AMERICANS WITH DISABILITIES ACT (ADA). FOR SHARED-USE PATH THE MAXIMUM RUNNING SLOPE IS 5%, MAXIMUM CROSS SLOPE IS 2%, AND MAXIMUM RAMP SLOPE IS 8.33%.
5. SIDE CURB ADJACENT TO PCC SHARED-USE PATH WILL BE MEASURED IN PLAN VIEW BY THE SQ FT AND PAID FOR AS PORTLAND CEMENT CONCRETE SIDEWALK, 5".
6. TRANSVERSE CONTRACTION JOINTS IN THE PCC SHARED-USE PATH SHALL BE SAWED NOT TOOLED.
7. THE AGGREGATE GRADATION FOR THE AGGREGATE SUBGRADE IMPROVEMENT 12" LOWER LIFT SHALL BE CS 1 OR RR 1.

MODEL: Default; FILE: M:\MFC\_Plan\benesch-pw\_bentley.com\benesch-pw\1\Documents\1\0700\107140\_001\Eng\_Docs\_Phase\_1\Roadway\Typical\_Sections\1\0700\107140\_001\Eng\_Docs\_Phase\_1\Roadway\Typical\_Sections\1\0700\107140\_001\Eng\_Docs\_Phase\_1\Roadway\Typical\_Sections\1\0700\107140\_001.dgn



USER NAME = jworthington  
 DESIGNED - JREAMBILLO  
 DRAWN - SPOPOVICI  
 CHECKED - POBRIEN  
 DATE - 02/04/2022

REVISOR  
 REVISION  
 REVISION  
 REVISION

**STATE OF ILLINOIS  
DEPARTMENT OF TRANSPORTATION**

**PROPOSED TYPICAL SECTION  
SEIL RD**

SCALE: AS SHOWN SHEET OF SHEETS STA. TO STA.

F.A./P.RTE.	SECTION	COUNTY	TOTAL SHEETS	SHEET NO.
*	2018-075-R	WILL	1510	61
CONTRACT NO. 62H15				
* FAI 55, FAP 338 ILLINOIS FED. AID PROJECT				

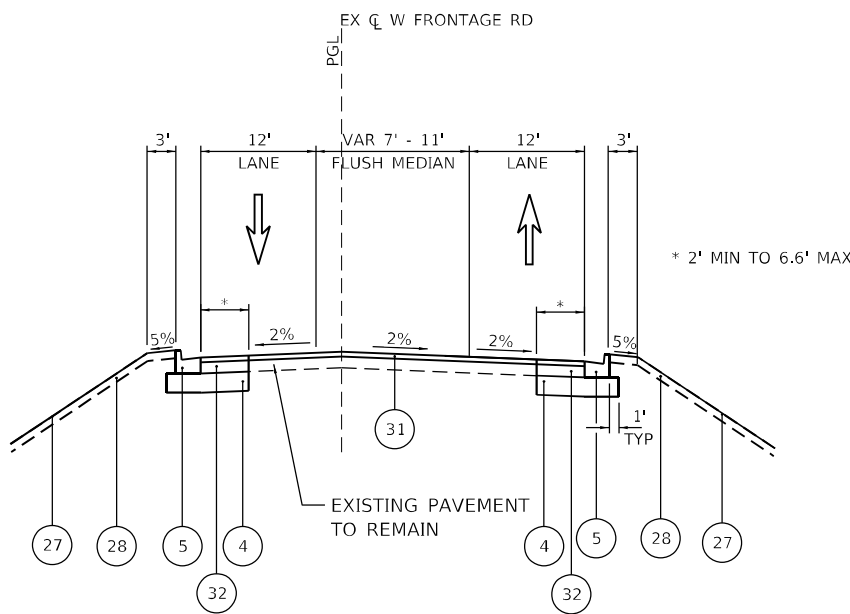

**PROPOSED TYPICAL SECTION  
W FRONTAGE RD**

STA 5540+42.36 TO STA 5541+86.60

NOTE: NONE OF THE ROADWAY GEOMETRY IS PARALLEL TO CENTERLINE.

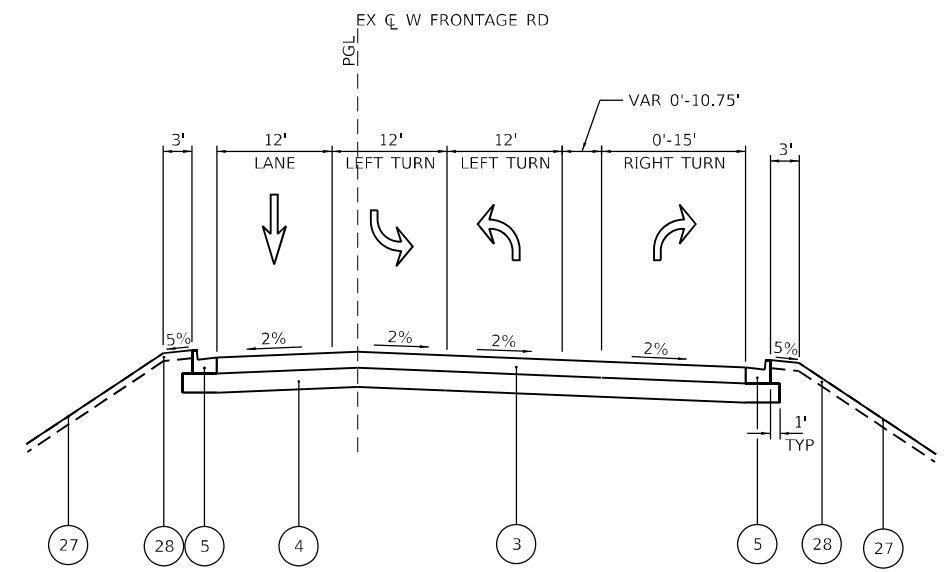

**PROPOSED TYPICAL SECTION  
W FRONTAGE RD**

STA 5541+86.60 TO STA 5544+88

NOTE: NONE OF THE ROADWAY GEOMETRY IS PARALLEL TO CENTERLINE.

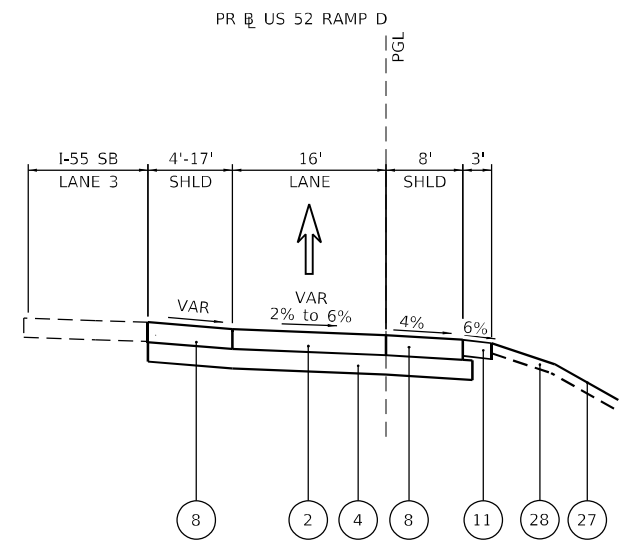

**PROPOSED TYPICAL SECTION  
US 52 RAMP D**

STA 200+66 TO STA 205+61

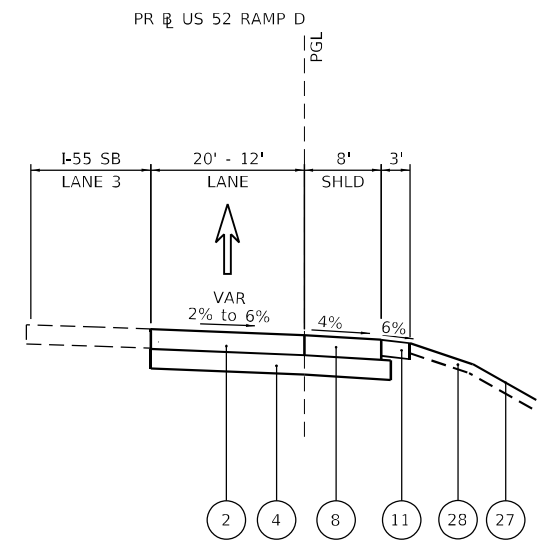

**PROPOSED TYPICAL SECTION  
US 52 RAMP D**

STA 205+61 TO STA 209+61

**LEGEND**

- 1 PORTLAND CEMENT CONCRETE PAVEMENT, 10" (JOINTED)
- 2 HOT-MIX ASPHALT PAVEMENT (FULL-DEPTH), 12.75"
- 3 HOT-MIX ASPHALT PAVEMENT (FULL-DEPTH), 10.25"
- 4 AGGREGATE SUBGRADE IMPROVEMENT, 12"
- 5 COMBINATION CONCRETE CURB AND GUTTER, TYPE B-6.24
- 6 COMBINATION CONCRETE CURB AND GUTTER, TYPE B-9.24
- 7 COMBINATION CONCRETE CURB AND GUTTER, TYPE M-4.24
- 8 HOT-MIX ASPHALT SHOULDERS, 12.75"
- 9 HOT-MIX ASPHALT PAVEMENT (FULL DEPTH), 9"
- 10 PORTLAND CEMENT CONCRETE SHOULDERS, 10"
- 11 AGGREGATE SHOULDERS, TYPE B 10"
- 12 TYPE B GUTTER
- 13 STAMPED COLORED PORTLAND CEMENT CONCRETE MEDIAN SURFACE, 6 INCH
- 14 CONCRETE MEDIAN, TYPE SB (SPECIAL)
- 15 CONCRETE MEDIAN SURFACE, 5 INCH
- 16 HOT-MIX ASPHALT SHARED-USE PATH (4")
- 17 PORTLAND CEMENT CONCRETE SIDEWALK 5 INCH
- 18 SUBBASE GRANULAR MATERIAL, TYPE B 6"
- 19 HOT-MIX ASPHALT PAVEMENT (FULL DEPTH), 15"
- 20 STEEL PLATE BEAM GUARDRAIL, TYPE A, 6 FOOT POSTS
- 21 HOT-MIX ASPHALT STABILIZATION 6" AT STEEL PLATE BEAM GUARD RAIL
- 22 CONCRETE BARRIER, SINGLE FACE, 44 INCH HEIGHT
- 23 HOT-MIX ASPHALT SURFACE COURSE, 1 1/2"
- 24 HOT-MIX ASPHALT SHOULDERS, 15"
- 25 HOT-MIX ASPHALT BINDER COURSE, 2 1/2"
- 26 RETAINING WALL (SEE STRUCTURAL PLANS)
- 27 SEEDING
- 28 TOPSOIL EXCAVATION AND PLACEMENT
- 29 PIPE UNDERDRAINS 6"
- 30 NOISE ABATEMENT WALL, GROUND MOUNTED
- 31 POLYMERIZED HOT-MIX ASPHALT SURFACE COURSE, IL-9.5, MIX "E", N70
- 32 HOT-MIX ASPHALT BASE COURSE, WIDENING (HMA BINDER IL-19.0)

**NOTES**

1. AT ROADWAY LOCATIONS WITH CURB AND GUTTER, THE PROPOSED GUARDRAIL FACE SHALL ALIGN WITH THE BACK OF CURB.
2. SEE HOT-MIX ASPHALT MIXTURE REQUIREMENTS CHART FOR MIXTURE DESIGN.
3. CURB AND GUTTER WITH REVERSE PITCH GUTTER SHALL MATCH THE ADJACENT PAVEMENT LANE SLOPE.
4. SHARED-USE PATH SHALL BE COMPLIANT WITH THE AMERICANS WITH DISABILITIES ACT (ADA). FOR SHARED-USE PATH THE MAXIMUM RUNNING SLOPE IS 5%, MAXIMUM CROSS SLOPE IS 2%, AND MAXIMUM RAMP SLOPE IS 8.33%.
5. SIDE CURB ADJACENT TO PCC SHARED-USE PATH WILL BE MEASURED IN PLAN VIEW BY THE SQ FT AND PAID FOR AS PORTLAND CEMENT CONCRETE SIDEWALK, 5".
6. TRANSVERSE CONTRACTION JOINTS IN THE PCC SHARED-USE PATH SHALL BE SAWED NOT TOOLED.
7. THE AGGREGATE GRADATION FOR THE AGGREGATE SUBGRADE IMPROVEMENT 12" LOWER LIFT SHALL BE CS 1 OR RR 1.

MODEL: Default; FILE NAME: p:\benesch-pw\_bentley.com\benesch\pwp\01\Documents\1107005\10740\_001\Eng\_Docs\_Phase\_1\Roadway\Typical\_Sections\1107005\115-shi-typical-pr-frontage-01.dgn



USER NAME = jworthington  
DESIGNED - JREAMBILLO  
DRAWN - SPOPOVICI  
CHECKED - POBRIEN  
DATE - 03/17/2022

REVISOR  
REVISION  
REVISOR  
REVISION  
REVISOR  
REVISION

**STATE OF ILLINOIS  
DEPARTMENT OF TRANSPORTATION**

**PROPOSED TYPICAL SECTIONS  
W FRONTAGE RD AND US 52 RAMP D**

SCALE: AS SHOWN SHEET OF SHEETS STA. Sta TO STA. ToSta

F.A./P. RTE.	SECTION	COUNTY	TOTAL SHEETS	SHEET NO.
*	2018-075-R	WILL	1510	62
CONTRACT NO. 62H15				
* FAI 55, FAP 338 ILLINOIS FED. AID PROJECT				

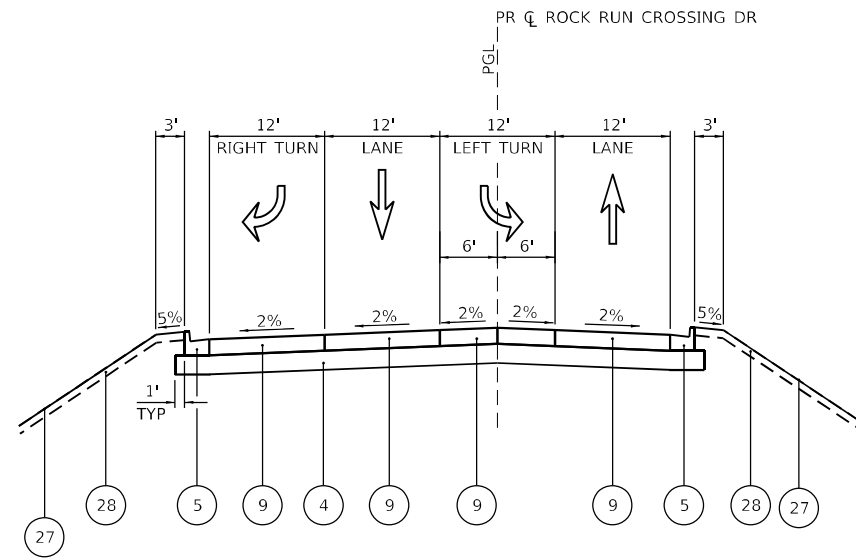

**PROPOSED TYPICAL SECTION  
ROCK RUN CROSSINGS DR**  
STA 6060+00 TO STA 6061+88

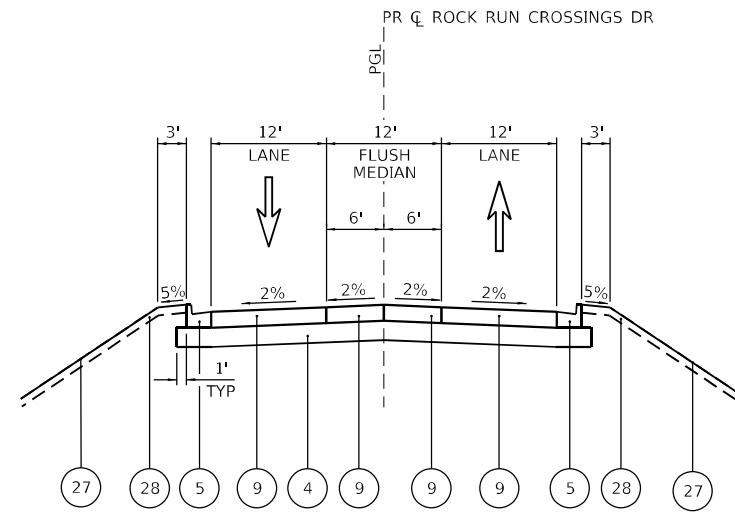

**PROPOSED TYPICAL SECTION  
ROCK RUN CROSSINGS DR**  
STA 6063+69 TO STA 6081+69

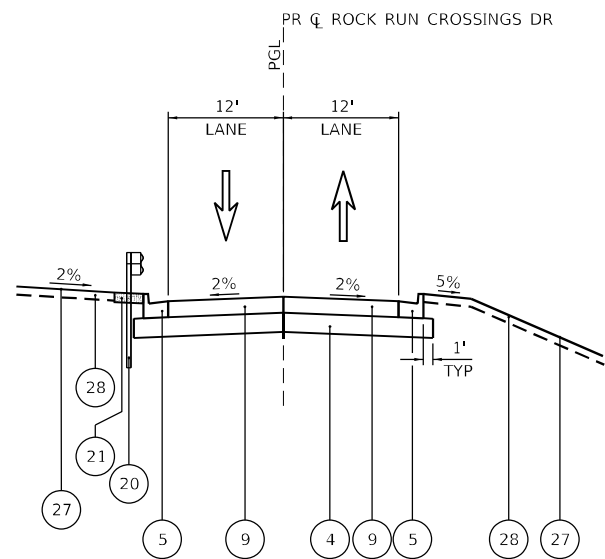

**PROPOSED TYPICAL SECTION  
ROCK RUN CROSSINGS DR**  
STA 6086+23 TO STA 6095+71

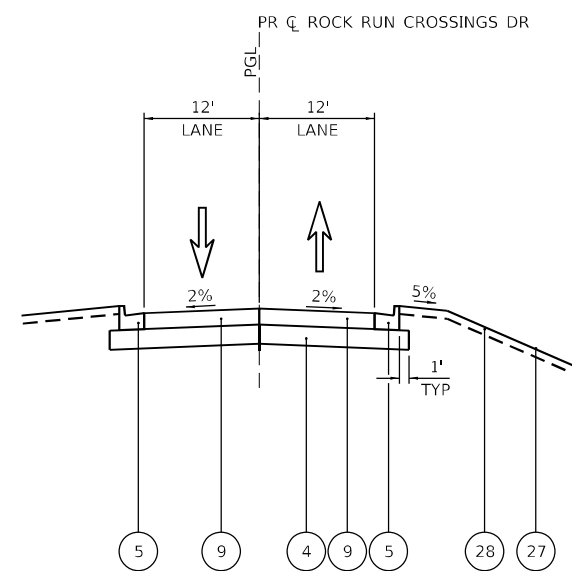

**PROPOSED TYPICAL SECTION  
ROCK RUN CROSSINGS DR**  
STA 6095+71 TO STA 6098+12

**LEGEND**

- 1 PORTLAND CEMENT CONCRETE PAVEMENT, 10" (JOINTED)
- 2 HOT-MIX ASPHALT PAVEMENT (FULL-DEPTH), 12.75"
- 3 HOT-MIX ASPHALT PAVEMENT (FULL-DEPTH), 10.25"
- 4 AGGREGATE SUBGRADE IMPROVEMENT, 12"
- 5 COMBINATION CONCRETE CURB AND GUTTER, TYPE B-6.24
- 6 COMBINATION CONCRETE CURB AND GUTTER, TYPE B-9.24
- 7 COMBINATION CONCRETE CURB AND GUTTER, TYPE M-4.24
- 8 HOT-MIX ASPHALT SHOULDERS, 12.75"
- 9 HOT-MIX ASPHALT PAVEMENT (FULL DEPTH), 9"
- 10 PORTLAND CEMENT CONCRETE SHOULDERS, 10"
- 11 AGGREGATE SHOULDERS, TYPE B 10"
- 12 TYPE B GUTTER
- 13 STAMPED COLORED PORTLAND CEMENT CONCRETE MEDIAN SURFACE, 6 INCH
- 14 CONCRETE MEDIAN, TYPE SB (SPECIAL)
- 15 CONCRETE MEDIAN SURFACE, 5 INCH
- 16 HOT-MIX ASPHALT SHARED-USE PATH (4")
- 17 PORTLAND CEMENT CONCRETE SIDEWALK 5 INCH
- 18 SUBBASE GRANULAR MATERIAL, TYPE B 6"
- 19 HOT-MIX ASPHALT PAVEMENT (FULL DEPTH), 15"
- 20 STEEL PLATE BEAM GUARDRAIL, TYPE A, 6 FOOT POSTS
- 21 HOT-MIX ASPHALT STABILIZATION 6" AT STEEL PLATE BEAM GUARD RAIL
- 22 CONCRETE BARRIER, SINGLE FACE, 44 INCH HEIGHT
- 23 HOT-MIX ASPHALT SURFACE COURSE, 1 1/2"
- 24 HOT-MIX ASPHALT SHOULDERS, 15"
- 25 HOT-MIX ASPHALT BINDER COURSE, 2 1/2"
- 26 RETAINING WALL (SEE STRUCTURAL PLANS)
- 27 SEEDING
- 28 TOPSOIL EXCAVATION AND PLACEMENT
- 29 PIPE UNDERDRAINS 6"
- 30 NOISE ABATEMENT WALL, GROUND MOUNTED

**NOTES**

1. AT ROADWAY LOCATIONS WITH CURB AND GUTTER, THE PROPOSED GUARDRAIL FACE SHALL ALIGN WITH THE BACK OF CURB.
2. SEE HOT-MIX ASPHALT MIXTURE REQUIREMENTS CHART FOR MIXTURE DESIGN.
3. CURB AND GUTTER WITH REVERSE PITCH GUTTER SHALL MATCH THE ADJACENT PAVEMENT LANE SLOPE.
4. SHARED-USE PATH SHALL BE COMPLIANT WITH THE AMERICANS WITH DISABILITIES ACT (ADA). FOR SHARED-USE PATH THE MAXIMUM RUNNING SLOPE IS 5%, MAXIMUM CROSS SLOPE IS 2%, AND MAXIMUM RAMP SLOPE IS 8.33%.
5. SIDE CURB ADJACENT TO PCC SHARED-USE PATH WILL BE MEASURED IN PLAN VIEW BY THE SQ FT AND PAID FOR AS PORTLAND CEMENT CONCRETE SIDEWALK, 5".
6. TRANSVERSE CONTRACTION JOINTS IN THE PCC SHARED-USE PATH SHALL BE SAWED NOT TOOLED.
7. THE AGGREGATE GRADATION FOR THE AGGREGATE SUBGRADE IMPROVEMENT 12" LOWER LIFT SHALL BE CS 1 OR RR 1.

MODEL: Default; FILE: 62H15-shi-typical-pr-center-01.dgn; PROJECT: 62H15-shi-typical-pr-center-01.dgn; PHASE: Phase 1; ROADWAY: Typical Sections; DATE: 10/14/2020; USER: jworthington



USER NAME = jworthington  
 DESIGNED - JREAMBILLO  
 DRAWN - SPOPOVICI  
 CHECKED - POBRIEN  
 DATE - 02/04/2022

REVISOR -  
 REVISION -  
 REVISION -  
 REVISION -

**STATE OF ILLINOIS  
DEPARTMENT OF TRANSPORTATION**

**PROPOSED TYPICAL SECTIONS  
ROCK RUN CROSSINGS DR**

SCALE: AS SHOWN SHEET OF SHEETS STA. TO STA.

F.A./P.RTE.	SECTION	COUNTY	TOTAL SHEETS	SHEET NO.
*	2018-075-R	WILL	1510	63
CONTRACT NO. 62H15				
* FAI 55, FAP 338 ILLINOIS FED. AID PROJECT				

**LEGEND**

- 1 PORTLAND CEMENT CONCRETE PAVEMENT, 10" (JOINTED)
- 2 HOT-MIX ASPHALT PAVEMENT (FULL-DEPTH), 12.75"
- 3 HOT-MIX ASPHALT PAVEMENT (FULL-DEPTH), 10.25"
- 4 AGGREGATE SUBGRADE IMPROVEMENT, 12"
- 5 COMBINATION CONCRETE CURB AND GUTTER, TYPE B-6.24
- 6 COMBINATION CONCRETE CURB AND GUTTER, TYPE B-9.24
- 7 COMBINATION CONCRETE CURB AND GUTTER, TYPE M-4.24
- 8 HOT-MIX ASPHALT SHOULDERS, 12.75"
- 9 HOT-MIX ASPHALT PAVEMENT (FULL DEPTH), 9"
- 10 PORTLAND CEMENT CONCRETE SHOULDERS, 10"
- 11 AGGREGATE SHOULDERS, TYPE B 10"
- 12 TYPE B GUTTER
- 13 STAMPED COLORED PORTLAND CEMENT CONCRETE MEDIAN SURFACE, 6 INCH
- 14 CONCRETE MEDIAN, TYPE SB (SPECIAL)
- 15 CONCRETE MEDIAN SURFACE, 5 INCH
- 16 HOT-MIX ASPHALT SHARED-USE PATH (4")
- 17 PORTLAND CEMENT CONCRETE SIDEWALK 5 INCH
- 18 SUBBASE GRANULAR MATERIAL, TYPE B 6"
- 19 HOT-MIX ASPHALT PAVEMENT (FULL DEPTH), 15"
- 20 STEEL PLATE BEAM GUARDRAIL, TYPE A, 6 FOOT POSTS
- 21 HOT-MIX ASPHALT STABILIZATION 6" AT STEEL PLATE BEAM GUARD RAIL
- 22 CONCRETE BARRIER, SINGLE FACE, 44 INCH HEIGHT
- 23 HOT-MIX ASPHALT SURFACE COURSE, 1 1/2"
- 24 HOT-MIX ASPHALT SHOULDERS, 15"
- 25 HOT-MIX ASPHALT BINDER COURSE, 2 1/2"
- 26 RETAINING WALL (SEE STRUCTURAL PLANS)
- 27 SEEDING
- 28 TOPSOIL EXCAVATION AND PLACEMENT
- 29 PIPE UNDERDRAINS 6"
- 30 NOISE ABATEMENT WALL, GROUND MOUNTED

**NOTES**

1. AT ROADWAY LOCATIONS WITH CURB AND GUTTER, THE PROPOSED GUARDRAIL FACE SHALL ALIGN WITH THE BACK OF CURB.
2. SEE HOT-MIX ASPHALT MIXTURE REQUIREMENTS CHART FOR MIXTURE DESIGN.
3. CURB AND GUTTER WITH REVERSE PITCH GUTTER SHALL MATCH THE ADJACENT PAVEMENT LANE SLOPE.
4. SHARED-USE PATH SHALL BE COMPLIANT WITH THE AMERICANS WITH DISABILITIES ACT (ADA). FOR SHARED-USE PATH THE MAXIMUM RUNNING SLOPE IS 5%, MAXIMUM CROSS SLOPE IS 2%, AND MAXIMUM RAMP SLOPE IS 8.33%.
5. SIDE CURB ADJACENT TO PCC SHARED-USE PATH WILL BE MEASURED IN PLAN VIEW BY THE SQ FT AND PAID FOR AS PORTLAND CEMENT CONCRETE SIDEWALK, 5".
6. TRANSVERSE CONTRACTION JOINTS IN THE PCC SHARED-USE PATH SHALL BE SAWED NOT TOOLED.
7. THE AGGREGATE GRADATION FOR THE AGGREGATE SUBGRADE IMPROVEMENT 12" LOWER LIFT SHALL BE CS 1 OR RR 1.

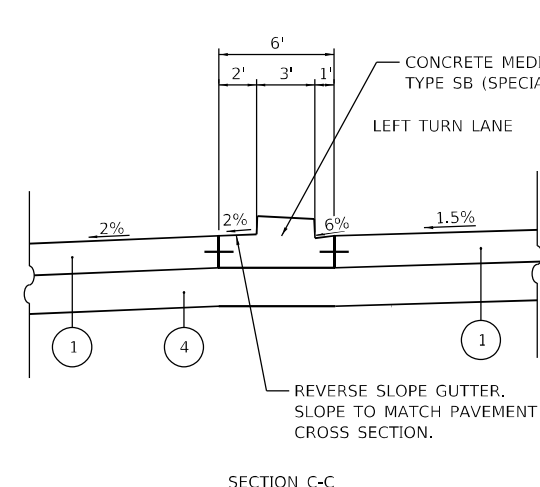
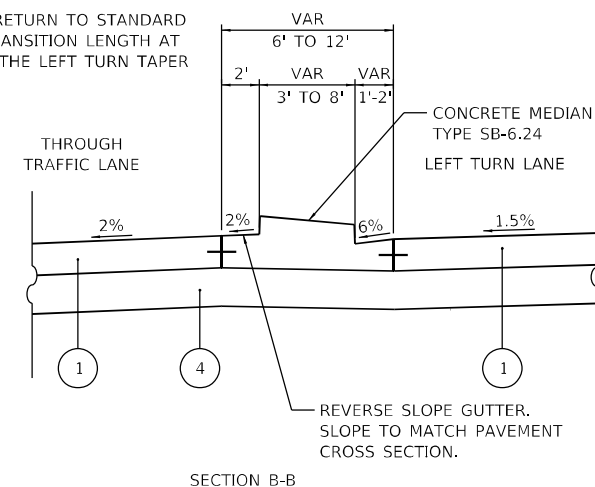
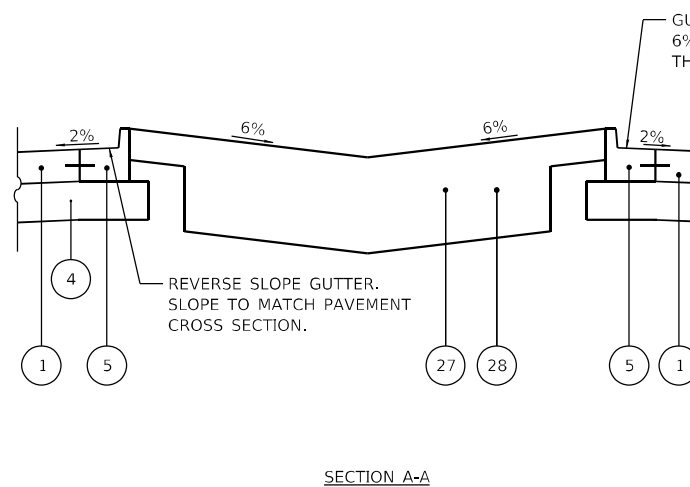
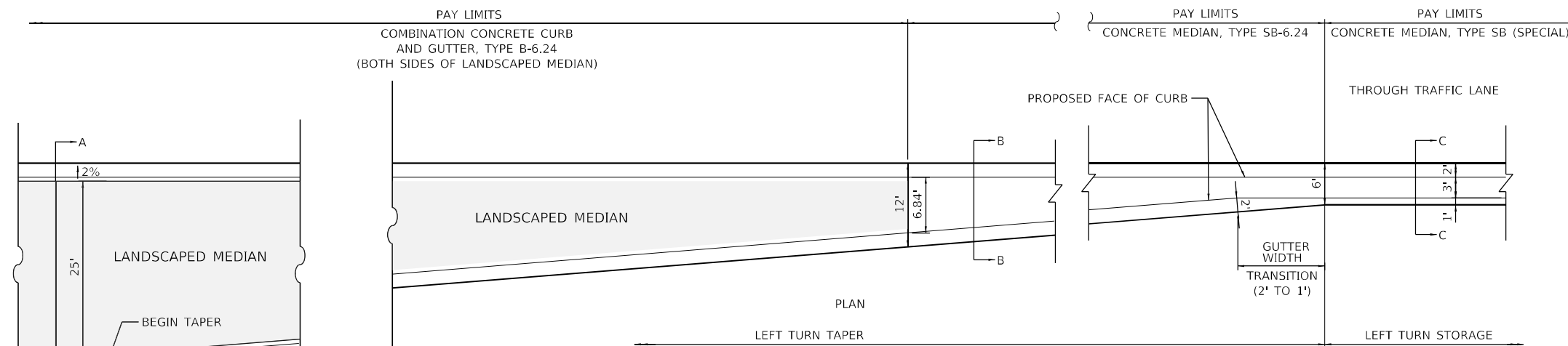

**CONCRETE MEDIAN TYPE SB (SPECIAL) AT DOUBLE LEFT TURN LANE**

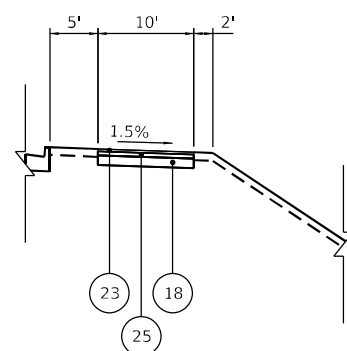

NOTE 1:  
SEE HOT-MIX ASPHALT MIXTURE REQUIREMENTS CHART FOR MIXTURE DESIGN.

**HOT-MIX ASPHALT SHARED-USE PATH, 4"**

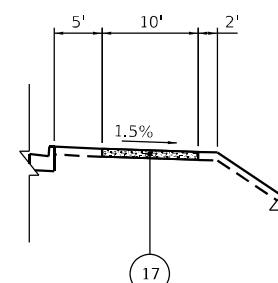

NOTE:  
PCC SIDEWALK 5" TO BE CONSTRUCTED DIRECTLY ON COMPACTED SUBGRADE

**PORTLAND CEMENT CONCRETE SHARED-USE PATH, 5"**

MODEL: Default; FILE: M:\MFC\_Plan\benesch-pw-bentley.com\benesch-pw-01\Documents\107005\10740\_001\Eng\_Docs\_Phase\_1\Roadway\Typical\_Sections\162H15-shi-typical-pr-path-01.dgn



USER NAME = jworthington	DESIGNED - JREAMBILLO	REVISED -
PLOT SCALE = 240,0000' / ft.	DRAWN - AGIBSON	REVISED -
PLOT DATE = 2/7/2022	CHECKED - POBRIEN	REVISED -
	DATE - 02/04/2022	REVISED -

**STATE OF ILLINOIS DEPARTMENT OF TRANSPORTATION**

**PROPOSED TYPICAL SECTION DETAILS**

SCALE: AS SHOWN SHEET OF SHEETS STA. TO STA.

F.A./P.RTE.	SECTION	COUNTY	TOTAL SHEETS	SHEET NO.
*	2018-075-R	WILL	1510	64
CONTRACT NO. 62H15				
* FAI 55, FAP 338 ILLINOIS FED. AID PROJECT				



EARTHWORK SCHEDULE OF QUANTITIES

Table with 22 columns: STATION TO STATION, LENGTH (FT), EARTH EXCAVATION (CUBIC YARDS), EARTH EXCAVATION ADJUSTED FOR SHRINKAGE (85%) (CUBIC YARDS), EMBANKMENT (CUBIC YARDS), and EARTHWORK BALANCE WASTE (CUBIC YARDS). Rows include stationing from 223+00.00 to 285+00.00.

MODEL: Default... I:\... \Benesch\proj\benesch-ar\benesch-ar\benesch-ar\benesch-ar\Documents\1070510740\_001\Eng\_Docs\_Phase\_1\General\162H15-shl-schedule-01.dgn

benesch logo and contact information: Alfred Benesch & Company, 35 W Wacker Drive, Suite 3300, Chicago, Illinois 60601, 312-565-0450, Job No. 10740

USER NAME = nReynolds, DESIGNED - DRAWN - CHECKED - DATE - 02/04/2022, REVISED - REVISED - REVISED - REVISED -

STATE OF ILLINOIS DEPARTMENT OF TRANSPORTATION

SCHEDULE OF QUANTITIES EARTHWORK, SCALE: NO SCALE SHEET OF SHEETS STA. TO STA.

F.A./P RTE., SECTION 2018-075-R, COUNTY WILL, TOTAL SHEETS 1510, SHEET NO. 65, CONTRACT NO. 62H15

**EARTHWORK SCHEDULE OF QUANTITIES**

STATION TO STATION	LENGTH (FT)	EARTH EXCAVATION					EARTH EXCAVATION ADJUSTED FOR SHRINKAGE (85%)					EMBANKMENT					EARTHWORK BALANCE WASTE							
	(FT)	(CUBIC YARDS)	(CUBIC YARDS)	(CUBIC YARDS)	(CUBIC YARDS)	(CUBIC YARDS)	(CUBIC YARDS)	(CUBIC YARDS)	(CUBIC YARDS)	(CUBIC YARDS)	(CUBIC YARDS)	(CUBIC YARDS)	(CUBIC YARDS)	(CUBIC YARDS)	(CUBIC YARDS)	(CUBIC YARDS)	(CUBIC YARDS)	(CUBIC YARDS)	(CUBIC YARDS)	(CUBIC YARDS)	(CUBIC YARDS)			
		STAGE 1	STAGE 1A	STAGE 2	STAGE 2A	STAGE 3	STAGE 1	STAGE 1A	STAGE 2	STAGE 2A	STAGE 3	STAGE 1	STAGE 1A	STAGE 2	STAGE 2A	STAGE 3	STAGE 1	STAGE 1A	STAGE 2	STAGE 2A	STAGE 3			
285+50.00	286+00.00	50.0	1600.0	0.0	0.0	0.0	0.0	0.0	0.0	0.0	0.0	0.0	0.0	0.0	0.0	0.0	0.0	0.0	0.0	0.0	0.0	0.0		
286+00.00	286+50.00	50.0	1835.0	0.0	0.0	0.0	0.0	0.0	0.0	0.0	0.0	0.0	0.0	0.0	0.0	0.0	0.0	0.0	0.0	0.0	0.0	0.0		
286+50.00	287+00.00	50.0	1963.0	0.0	0.0	0.0	0.0	0.0	0.0	0.0	0.0	0.0	0.0	0.0	0.0	0.0	0.0	0.0	0.0	0.0	0.0	0.0		
287+00.00	287+50.00	50.0	2194.0	0.0	0.0	0.0	0.0	0.0	0.0	0.0	0.0	0.0	0.0	0.0	0.0	0.0	0.0	0.0	0.0	0.0	0.0	0.0		
287+50.00	288+00.00	50.0	2431.0	0.0	0.0	0.0	0.0	0.0	0.0	0.0	0.0	0.0	0.0	0.0	0.0	0.0	0.0	0.0	0.0	0.0	0.0	0.0		
288+00.00	288+50.00	50.0	2443.0	0.0	0.0	0.0	0.0	0.0	0.0	0.0	0.0	0.0	0.0	0.0	0.0	0.0	0.0	0.0	0.0	0.0	0.0	0.0		
288+50.00	289+00.00	50.0	2490.0	0.0	0.0	0.0	0.0	0.0	0.0	0.0	0.0	0.0	0.0	0.0	0.0	0.0	0.0	0.0	0.0	0.0	0.0	0.0		
289+00.00	289+50.00	50.0	2531.0	0.0	0.0	0.0	0.0	0.0	0.0	0.0	0.0	0.0	0.0	0.0	0.0	0.0	0.0	0.0	0.0	0.0	0.0	0.0		
289+50.00	290+00.00	50.0	1575.0	0.0	16.0	0.0	0.0	0.0	0.0	0.0	1339.0	0.0	14.0	0.0	0.0	88.0	0.0	75.0	0.0	0.0	1251.0	0.0	-61.0	0.0
290+00.00	290+50.00	50.0	440.0	0.0	30.0	0.0	0.0	0.0	0.0	0.0	374.0	0.0	26.0	0.0	0.0	106.0	0.0	151.0	0.0	0.0	268.0	0.0	-125.0	0.0
290+50.00	291+00.00	50.0	265.0	0.0	30.0	0.0	0.0	0.0	0.0	0.0	226.0	0.0	26.0	0.0	0.0	122.0	0.0	149.0	0.0	0.0	104.0	0.0	-123.0	0.0
291+00.00	291+50.00	50.0	346.0	0.0	31.0	0.0	0.0	0.0	0.0	0.0	295.0	0.0	27.0	0.0	0.0	465.0	0.0	149.0	0.0	0.0	-170.0	0.0	-122.0	0.0
291+50.00	292+00.00	50.0	483.0	0.0	31.0	0.0	0.0	0.0	0.0	0.0	411.0	0.0	27.0	0.0	0.0	783.0	0.0	152.0	0.0	0.0	-372.0	0.0	-125.0	0.0
292+00.00	292+50.00	50.0	700.0	0.0	29.0	0.0	0.0	0.0	0.0	0.0	595.0	0.0	25.0	0.0	0.0	596.0	0.0	150.0	0.0	0.0	-1.0	0.0	-125.0	0.0
292+50.00	293+00.00	50.0	1162.0	0.0	30.0	0.0	0.0	0.0	0.0	0.0	988.0	0.0	26.0	0.0	0.0	270.0	0.0	148.0	0.0	0.0	718.0	0.0	-122.0	0.0
293+00.00	293+50.00	50.0	1934.0	0.0	33.0	0.0	0.0	0.0	0.0	0.0	1644.0	0.0	29.0	0.0	0.0	85.0	0.0	136.0	0.0	0.0	1559.0	0.0	-107.0	0.0
293+50.00	294+00.00	50.0	2892.0	0.0	33.0	0.0	0.0	0.0	0.0	0.0	2459.0	0.0	29.0	0.0	0.0	47.0	0.0	131.0	0.0	0.0	2412.0	0.0	-102.0	0.0
294+00.00	294+50.00	50.0	3499.0	0.0	33.0	0.0	0.0	0.0	0.0	0.0	2975.0	0.0	29.0	0.0	0.0	54.0	0.0	140.0	0.0	0.0	2921.0	0.0	-111.0	0.0
294+50.00	295+00.00	50.0	3802.0	0.0	30.0	0.0	0.0	0.0	0.0	0.0	3232.0	0.0	26.0	0.0	0.0	93.0	0.0	137.0	0.0	0.0	3139.0	0.0	-111.0	0.0
295+00.00	295+50.00	50.0	3111.0	0.0	29.0	0.0	0.0	0.0	0.0	0.0	2845.0	0.0	25.0	0.0	0.0	113.0	0.0	124.0	0.0	0.0	2532.0	0.0	-99.0	0.0
295+50.00	296+00.00	50.0	2542.0	0.0	25.0	0.0	0.0	0.0	0.0	0.0	2161.0	0.0	22.0	0.0	0.0	62.0	0.0	99.0	0.0	0.0	2099.0	0.0	-77.0	0.0
296+00.00	296+50.00	50.0	3431.0	0.0	58.0	0.0	0.0	0.0	0.0	0.0	2917.0	0.0	50.0	0.0	0.0	25.0	0.0	40.0	0.0	0.0	2892.0	0.0	10.0	0.0
296+50.00	297+00.00	50.0	4829.0	0.0	126.0	0.0	0.0	0.0	0.0	0.0	4105.0	0.0	108.0	0.0	0.0	40.0	0.0	0.0	0.0	0.0	4065.0	0.0	108.0	0.0
297+00.00	297+50.00	50.0	6193.0	0.0	147.0	0.0	0.0	0.0	0.0	0.0	5265.0	0.0	125.0	0.0	0.0	130.0	0.0	0.0	0.0	0.0	5135.0	0.0	125.0	0.0
297+50.00	298+00.00	50.0	7318.0	0.0	80.0	0.0	0.0	0.0	0.0	0.0	8221.0	0.0	68.0	0.0	0.0	384.0	0.0	90.0	0.0	0.0	5837.0	0.0	-22.0	0.0
298+00.00	298+50.00	50.0	7444.0	0.0	32.0	0.0	0.0	0.0	0.0	0.0	3320.0	0.0	20.0	0.0	0.0	311.0	0.0	229.0	0.0	0.0	6017.0	0.0	-201.0	0.0
298+50.00	299+00.00	50.0	6027.0	0.0	45.0	0.0	0.0	0.0	0.0	0.0	5123.0	0.0	39.0	0.0	0.0	69.0	0.0	366.0	0.0	0.0	5054.0	0.0	-327.0	0.0
299+00.00	299+50.00	50.0	4329.0	0.0	63.0	0.0	0.0	0.0	0.0	0.0	3680.0	0.0	54.0	0.0	0.0	77.0	0.0	414.0	0.0	0.0	3603.0	0.0	-360.0	0.0
299+50.00	300+00.00	50.0	2598.0	0.0	82.0	0.0	0.0	0.0	0.0	0.0	2209.0	0.0	70.0	0.0	0.0	91.0	0.0	367.0	0.0	0.0	2118.0	0.0	-297.0	0.0
300+00.00	300+50.00	50.0	822.0	0.0	78.0	0.0	0.0	0.0	0.0	0.0	699.0	0.0	65.0	0.0	0.0	229.0	0.0	375.0	0.0	0.0	470.0	0.0	-310.0	0.0
300+50.00	301+00.00	50.0	31.0	0.0	68.0	0.0	0.0	0.0	0.0	0.0	27.0	0.0	58.0	0.0	0.0	192.0	0.0	282.0	0.0	0.0	-165.0	0.0	-224.0	0.0
301+00.00	301+50.00	50.0	14.0	0.0	92.0	0.0	0.0	0.0	0.0	0.0	12.0	0.0	79.0	0.0	0.0	49.0	0.0	223.0	0.0	0.0	-37.0	0.0	-144.0	0.0
301+50.00	302+00.00	50.0	0.0	0.0	106.0	0.0	0.0	0.0	0.0	0.0	0.0	0.0	91.0	0.0	0.0	66.0	0.0	240.0	0.0	0.0	-66.0	0.0	-149.0	0.0
302+00.00	302+50.00	50.0	0.0	0.0	100.0	0.0	0.0	0.0	0.0	0.0	0.0	0.0	85.0	0.0	0.0	67.0	0.0	208.0	0.0	0.0	-67.0	0.0	-123.0	0.0
302+50.00	303+00.00	50.0	0.0	0.0	98.0	0.0	0.0	0.0	0.0	0.0	0.0	0.0	84.0	0.0	0.0	75.0	0.0	201.0	0.0	0.0	-75.0	0.0	-117.0	0.0
303+00.00	303+50.00	50.0	0.0	0.0	91.0	0.0	0.0	0.0	0.0	0.0	0.0	0.0	78.0	0.0	0.0	78.0	0.0	198.0	0.0	0.0	-78.0	0.0	-120.0	0.0
303+50.00	304+00.00	50.0	0.0	0.0	89.0	0.0	0.0	0.0	0.0	0.0	0.0	0.0	76.0	0.0	0.0	75.0	0.0	192.0	0.0	0.0	-75.0	0.0	-116.0	0.0
304+00.00	304+50.00	60.0	1.0	0.0	88.0	0.0	0.0	0.0	0.0	0.0	1.0	0.0	75.0	0.0	0.0	74.0	0.0	178.0	0.0	0.0	-73.0	0.0	-103.0	0.0
304+50.00	305+00.00	50.0	1.0	0.0	88.0	0.0	0.0	0.0	0.0	0.0	1.0	0.0	75.0	0.0	0.0	75.0	0.0	166.0	0.0	0.0	-74.0	0.0	-91.0	0.0
305+00.00	305+50.00	50.0	1.0	0.0	97.0	0.0	0.0	0.0	0.0	0.0	1.0	0.0	83.0	0.0	0.0	72.0	0.0	150.0	0.0	0.0	-71.0	0.0	-67.0	0.0
305+50.00	306+00.00	50.0	16.0	0.0	105.0	0.0	0.0	0.0	0.0	0.0	14.0	0.0	90.0	0.0	0.0	63.0	0.0	138.0	0.0	0.0	-49.0	0.0	-48.0	0.0

MODEL: Default  
 FILE: M:\AEC\Projects\benesch\paw\benesch\paw\benesch\paw\107015-01\107015-01\Eng\_Docs\_Phase\_1\General\107015-shl-schedule-02.dgn  
 User: nReynolds  
 Plot Scale: = 24,0000 \* / ft.  
 Plot Date: = 2/7/2022



USER NAME = nReynolds	DESIGNED -	REVISED -
	DRAWN -	REVISED -
PLOT SCALE = 24,0000 * / ft.	CHECKED -	REVISED -
PLOT DATE = 2/7/2022	DATE = 02/04/2022	REVISED -

**STATE OF ILLINOIS  
DEPARTMENT OF TRANSPORTATION**

**SCHEDULE OF QUANTITIES  
EARTHWORK**

SCALE: NO SCALE    SHEET    OF    SHEETS    STA.    TO STA.

F.A./P RTE.	SECTION	COUNTY	TOTAL SHEETS	SHEET NO.
*	2018-075-R	WILL	1510	66
CONTRACT NO. 62H15				
© FAI 55, FAP 338    ILLINOIS    FED. AID PROJECT				

### EARTHWORK SCHEDULE OF QUANTITIES

STATION TO STATION		LENGTH (FT)	EARTH EXCAVATION					EARTH EXCAVATION ADJUSTED FOR SHRINKAGE (85%)					EMBANKMENT					EARTHWORK BALANCE WASTE								
			(FT)	(CUBIC YARDS)	(CUBIC YARDS)	(CUBIC YARDS)	(CUBIC YARDS)	(CUBIC YARDS)	(CUBIC YARDS)	(CUBIC YARDS)	(CUBIC YARDS)	(CUBIC YARDS)	(CUBIC YARDS)	(CUBIC YARDS)	(CUBIC YARDS)	(CUBIC YARDS)	(CUBIC YARDS)	(CUBIC YARDS)	(CUBIC YARDS)	(CUBIC YARDS)	(CUBIC YARDS)					
			STAGE 1	STAGE 1A	STAGE 2	STAGE 2A	STAGE 3	STAGE 1	STAGE 1A	STAGE 2	STAGE 2A	STAGE 3	STAGE 1	STAGE 1A	STAGE 2	STAGE 2A	STAGE 3	STAGE 1	STAGE 1A	STAGE 2	STAGE 2A	STAGE 3				
306+00.00	306+50.00	50.0	29.0	0.0	117.0	0.0	0.0	25.0	0.0	100.0	0.0	0.0	63.0	0.0	127.0	0.0	0.0	-38.0	0.0	-27.0	0.0	0.0				
306+50.00	307+00.00	50.0	26.0	0.0	148.0	0.0	0.0	23.0	0.0	126.0	0.0	0.0	69.0	0.0	112.0	0.0	0.0	-46.0	0.0	14.0	0.0	0.0				
307+00.00	307+50.00	50.0	25.0	0.0	177.0	0.0	0.0	22.0	0.0	151.0	0.0	0.0	72.0	0.0	105.0	0.0	0.0	-50.0	0.0	46.0	0.0	0.0				
307+50.00	308+00.00	50.0	29.0	0.0	187.0	0.0	0.0	25.0	0.0	159.0	0.0	0.0	79.0	0.0	112.0	0.0	0.0	-54.0	0.0	47.0	0.0	0.0				
308+00.00	308+50.00	50.0	29.0	0.0	188.0	0.0	0.0	25.0	0.0	160.0	0.0	0.0	82.0	0.0	110.0	0.0	0.0	-57.0	0.0	50.0	0.0	0.0				
308+50.00	309+00.00	50.0	28.0	0.0	180.0	0.0	0.0	24.0	0.0	153.0	0.0	0.0	85.0	0.0	107.0	0.0	0.0	-61.0	0.0	46.0	0.0	0.0				
309+00.00	309+50.00	50.0	30.0	0.0	159.0	0.0	0.0	26.0	0.0	136.0	0.0	0.0	92.0	0.0	120.0	0.0	0.0	-66.0	0.0	16.0	0.0	0.0				
309+50.00	310+00.00	50.0	30.0	0.0	120.0	0.0	0.0	26.0	0.0	102.0	0.0	0.0	96.0	0.0	138.0	0.0	0.0	-70.0	0.0	-36.0	0.0	0.0				
310+00.00	310+50.00	50.0	15.0	0.0	92.0	0.0	0.0	13.0	0.0	79.0	0.0	0.0	99.0	0.0	153.0	0.0	0.0	-86.0	0.0	-74.0	0.0	0.0				
310+50.00	311+00.00	50.0	0.0	0.0	103.0	0.0	0.0	0.0	0.0	88.0	0.0	0.0	100.0	0.0	138.0	0.0	0.0	-100.0	0.0	-50.0	0.0	0.0				
311+00.00	311+50.00	50.0	0.0	0.0	123.0	0.0	0.0	0.0	0.0	105.0	0.0	0.0	96.0	0.0	108.0	0.0	0.0	-96.0	0.0	-3.0	0.0	0.0				
311+50.00	312+00.00	50.0	0.0	0.0	123.0	0.0	0.0	0.0	0.0	105.0	0.0	0.0	88.0	0.0	100.0	0.0	0.0	-88.0	0.0	5.0	0.0	0.0				
312+00.00	312+50.00	50.0	0.0	0.0	107.0	0.0	0.0	0.0	0.0	91.0	0.0	0.0	79.0	0.0	102.0	0.0	0.0	-79.0	0.0	-11.0	0.0	0.0				
312+50.00	313+00.00	50.0	0.0	0.0	100.0	0.0	0.0	0.0	0.0	85.0	0.0	0.0	75.0	0.0	97.0	0.0	0.0	-75.0	0.0	-12.0	0.0	0.0				
313+00.00	313+50.00	50.0	0.0	0.0	90.0	0.0	0.0	0.0	0.0	77.0	0.0	0.0	69.0	0.0	84.0	0.0	0.0	-69.0	0.0	-7.0	0.0	0.0				
313+50.00	314+00.00	50.0	13.0	0.0	85.0	0.0	0.0	12.0	0.0	73.0	0.0	0.0	60.0	0.0	67.0	0.0	0.0	-48.0	0.0	6.0	0.0	0.0				
314+00.00	314+50.00	50.0	27.0	0.0	96.0	0.0	0.0	23.0	0.0	82.0	0.0	0.0	56.0	0.0	57.0	0.0	0.0	-33.0	0.0	25.0	0.0	0.0				
314+50.00	315+00.00	50.0	29.0	0.0	114.0	0.0	0.0	25.0	0.0	97.0	0.0	0.0	53.0	0.0	56.0	0.0	0.0	-28.0	0.0	41.0	0.0	0.0				
315+00.00	315+50.00	50.0	35.0	0.0	143.0	0.0	0.0	30.0	0.0	122.0	0.0	0.0	50.0	0.0	50.0	0.0	0.0	-20.0	0.0	72.0	0.0	0.0				
315+50.00	316+00.00	50.0	40.0	0.0	178.0	0.0	0.0	34.0	0.0	152.0	0.0	0.0	49.0	0.0	43.0	0.0	0.0	-15.0	0.0	109.0	0.0	0.0				
316+00.00	316+50.00	50.0	50.0	0.0	208.0	0.0	0.0	43.0	0.0	177.0	0.0	0.0	46.0	0.0	36.0	0.0	0.0	-3.0	0.0	141.0	0.0	0.0				
316+50.00	317+00.00	50.0	58.0	0.0	230.0	0.0	0.0	50.0	0.0	196.0	0.0	0.0	44.0	0.0	35.0	0.0	0.0	6.0	0.0	161.0	0.0	0.0				
317+00.00	317+50.00	50.0	54.0	0.0	255.0	0.0	0.0	46.0	0.0	217.0	0.0	0.0	45.0	0.0	34.0	0.0	0.0	1.0	0.0	183.0	0.0	0.0				
317+50.00	318+00.00	50.0	51.0	0.0	308.0	0.0	0.0	44.0	0.0	262.0	0.0	0.0	46.0	0.0	32.0	0.0	0.0	-2.0	0.0	230.0	0.0	0.0				
318+00.00	318+50.00	50.0	58.0	0.0	353.0	0.0	0.0	48.0	0.0	301.0	0.0	0.0	46.0	0.0	31.0	0.0	0.0	2.0	0.0	270.0	0.0	0.0				
318+50.00	319+00.00	50.0	66.0	0.0	369.0	0.0	0.0	57.0	0.0	314.0	0.0	0.0	42.0	0.0	30.0	0.0	0.0	15.0	0.0	284.0	0.0	0.0				
319+00.00	319+50.00	50.0	85.0	0.0	391.0	0.0	0.0	73.0	0.0	333.0	0.0	0.0	36.0	0.0	30.0	0.0	0.0	37.0	0.0	303.0	0.0	0.0				
319+50.00	320+00.00	50.0	89.0	0.0	387.0	0.0	0.0	76.0	0.0	329.0	0.0	0.0	34.0	0.0	27.0	0.0	0.0	42.0	0.0	302.0	0.0	0.0				
320+00.00	320+50.00	50.0	86.0	0.0	362.0	0.0	0.0	74.0	0.0	308.0	0.0	0.0	33.0	0.0	23.0	0.0	0.0	41.0	0.0	285.0	0.0	0.0				
320+50.00	321+00.00	50.0	94.0	0.0	354.0	0.0	0.0	80.0	0.0	301.0	0.0	0.0	32.0	0.0	18.0	0.0	0.0	48.0	0.0	283.0	0.0	0.0				
321+00.00	321+50.00	50.0	112.0	0.0	318.0	0.0	0.0	96.0	0.0	271.0	0.0	0.0	27.0	0.0	15.0	0.0	0.0	69.0	0.0	256.0	0.0	0.0				
321+50.00	322+00.00	50.0	135.0	0.0	326.0	0.0	0.0	115.0	0.0	278.0	0.0	0.0	20.0	0.0	13.0	0.0	0.0	95.0	0.0	265.0	0.0	0.0				
322+00.00	322+50.00	50.0	148.0	0.0	354.0	0.0	0.0	126.0	0.0	301.0	0.0	0.0	18.0	0.0	12.0	0.0	0.0	108.0	0.0	269.0	0.0	0.0				
322+50.00	323+00.00	50.0	160.0	0.0	343.0	0.0	0.0	136.0	0.0	292.0	0.0	0.0	17.0	0.0	12.0	0.0	0.0	119.0	0.0	280.0	0.0	0.0				
323+00.00	323+50.00	50.0	174.0	0.0	356.0	0.0	0.0	148.0	0.0	303.0	0.0	0.0	14.0	0.0	12.0	0.0	0.0	134.0	0.0	291.0	0.0	0.0				
<b>SUBTOTAL</b>				87716.0	0.0	10971.0	0.0	0.0		74593.0	0.0	9370.0	0.0	0.0		7722.0	0.0	9955.0	0.0	0.0		66871.0	0.0	-585.0	0.0	0.0

MODEL: Default  
 FILE: \\benesch-pw-bentley.com\benesch-pw01\Documents\110205\10740\_00\Eng\_Docs\_Phase\_11\62H15-shl-schedule-03.dgn  
 D:\62H15-shl-schedule-03.dgn  
 50 107  
 2012/11/30



USER NAME = nReynolds	DESIGNED -	REVISED -
PLOT SCALE = 24,0000' +/-	CHECKED -	REVISED -
PLOT DATE = 2/7/2022	DATE = 02/04/2022	REVISED -

**STATE OF ILLINOIS  
DEPARTMENT OF TRANSPORTATION**

**SCHEDULE OF QUANTITIES  
EARTHWORK**

SCALE: NO SCALE SHEET OF SHEETS STA. TO STA.

F.A./P RTE.	SECTION	COUNTY	TOTAL SHEETS	SHEET NO.
	2018-075-R	WILL	1510	67
CONTRACT NO. 62H15				
F.A.I 55, FAP 338	ILLINOIS	FED. AID PROJECT		

EARTHWORK SCHEDULE OF QUANTITIES

STATION TO STATION	LENGTH (FT)	EARTH EXCAVATION					EARTH EXCAVATION ADJUSTED FOR SHRINKAGE (85%)					EMBANKMENT					EARTHWORK BALANCE WASTE					
	(FT)	(CUBIC YARDS)	(CUBIC YARDS)	(CUBIC YARDS)	(CUBIC YARDS)	(CUBIC YARDS)	(CUBIC YARDS)	(CUBIC YARDS)	(CUBIC YARDS)	(CUBIC YARDS)	(CUBIC YARDS)	(CUBIC YARDS)	(CUBIC YARDS)	(CUBIC YARDS)	(CUBIC YARDS)	(CUBIC YARDS)	(CUBIC YARDS)	(CUBIC YARDS)	(CUBIC YARDS)	(CUBIC YARDS)	(CUBIC YARDS)	
		STAGE 1	STAGE 1A	STAGE 2	STAGE 2A	STAGE 3	STAGE 1	STAGE 1A	STAGE 2	STAGE 2A	STAGE 3	STAGE 1	STAGE 1A	STAGE 2	STAGE 2A	STAGE 3	STAGE 1	STAGE 1A	STAGE 2	STAGE 2A	STAGE 3	
<b>IL 59 NORTH OF SEIL RD</b>																						
6990+00.00	6990+50.00	50.0	716.0	0.0	0.0	0.0	0.0	609.0	0.0	0.0	0.0	0.0	26.0	0.0	0.0	0.0	0.0	583.0	0.0	0.0	0.0	0.0
6990+50.00	6991+00.00	50.0	888.0	0.0	0.0	0.0	0.0	585.0	0.0	0.0	0.0	0.0	26.0	0.0	0.0	0.0	0.0	559.0	0.0	0.0	0.0	0.0
6991+00.00	6991+50.00	50.0	650.0	0.0	0.0	0.0	0.0	553.0	0.0	0.0	0.0	0.0	21.0	0.0	0.0	0.0	0.0	532.0	0.0	0.0	0.0	0.0
6991+50.00	6992+00.00	50.0	633.0	0.0	0.0	0.0	0.0	539.0	0.0	0.0	0.0	0.0	13.0	0.0	0.0	0.0	0.0	526.0	0.0	0.0	0.0	0.0
6992+00.00	6992+50.00	50.0	621.0	0.0	0.0	61.0	44.0	528.0	0.0	0.0	52.0	38.0	15.0	0.0	0.0	0.0	0.0	513.0	0.0	0.0	52.0	38.0
6992+50.00	6993+00.00	50.0	595.0	0.0	0.0	118.0	88.0	506.0	0.0	0.0	101.0	75.0	30.0	0.0	0.0	0.0	0.0	476.0	0.0	0.0	101.0	75.0
6993+00.00	6993+50.00	50.0	589.0	0.0	0.0	88.0	88.0	501.0	0.0	0.0	75.0	75.0	46.0	0.0	0.0	0.0	0.0	455.0	0.0	0.0	75.0	75.0
6993+50.00	6994+00.00	50.0	590.0	0.0	0.0	94.0	90.0	502.0	0.0	0.0	90.0	77.0	58.0	0.0	0.0	5.0	0.0	444.0	0.0	0.0	75.0	77.0
6994+00.00	6994+50.00	50.0	576.0	0.0	0.0	110.0	69.0	490.0	0.0	0.0	94.0	59.0	97.0	0.0	0.0	5.0	0.0	393.0	0.0	0.0	89.0	59.0
6994+50.00	6995+00.00	50.0	532.0	0.0	0.0	94.0	67.0	453.0	0.0	0.0	80.0	57.0	182.0	0.0	0.0	0.0	0.0	271.0	0.0	0.0	80.0	57.0
6995+00.00	6995+50.00	50.0	275.0	0.0	0.0	186.0	88.0	234.0	0.0	0.0	159.0	75.0	220.0	0.0	0.0	113.0	0.0	14.0	0.0	0.0	46.0	75.0
6995+50.00	6996+00.00	50.0	63.0	0.0	0.0	205.0	83.0	54.0	0.0	0.0	175.0	71.0	227.0	0.0	0.0	238.0	0.0	-173.0	0.0	0.0	-63.0	71.0
6996+00.00	6996+50.00	50.0	65.0	0.0	0.0	122.0	69.0	56.0	0.0	0.0	104.0	59.0	274.0	0.0	0.0	233.0	0.0	-218.0	0.0	0.0	-129.0	59.0
6996+50.00	6997+00.00	50.0	59.0	0.0	0.0	102.0	49.0	51.0	0.0	0.0	87.0	42.0	300.0	0.0	0.0	184.0	10.0	-249.0	0.0	0.0	-97.0	32.0
6997+00.00	6997+50.00	50.0	51.0	0.0	0.0	88.0	27.0	44.0	0.0	0.0	75.0	23.0	316.0	0.0	0.0	114.0	28.0	-272.0	0.0	0.0	-39.0	-5.0
6997+50.00	6998+00.00	50.0	48.0	0.0	0.0	84.0	18.0	41.0	0.0	0.0	72.0	16.0	338.0	0.0	0.0	83.0	35.0	-297.0	0.0	0.0	-11.0	-19.0
6998+00.00	6998+50.00	50.0	48.0	0.0	0.0	91.0	16.0	41.0	0.0	0.0	78.0	14.0	364.0	0.0	0.0	112.0	32.0	-323.0	0.0	0.0	-34.0	-18.0
6998+50.00	6999+00.00	50.0	138.0	0.0	0.0	88.0	18.0	118.0	0.0	0.0	75.0	16.0	783.0	0.0	0.0	113.0	25.0	-665.0	0.0	0.0	-38.0	-9.0
6999+00.00	6999+50.00	50.0	207.0	0.0	0.0	52.0	11.0	176.0	0.0	0.0	45.0	10.0	591.0	0.0	0.0	298.0	9.0	-415.0	0.0	0.0	-253.0	1.0
<b>SUBTOTAL</b>			7144.0	0.0	0.0	1583.0	825.0	8081.0	0.0	0.0	1352.0	707.0	3927.0	0.0	0.0	1498.0	139.0	2154.0	0.0	0.0	-146.0	568.0
<b>IL 59 SB</b>																						
7000+00.00	7000+50.00	50.0	0.0	101.0	0.0	109.0	41.0	0.0	06.0	0.0	161.0	35.0	463.0	0.0	0.0	106.0	0.0	-463.0	86.0	0.0	55.0	35.0
7000+50.00	7001+00.00	50.0	0.0	96.0	0.0	173.0	28.0	0.0	82.0	0.0	148.0	24.0	463.0	19.0	0.0	75.0	0.0	-463.0	63.0	0.0	73.0	24.0
7001+00.00	7001+50.00	50.0	38.0	38.0	0.0	152.0	17.0	33.0	31.0	0.0	130.0	15.0	475.0	19.0	0.0	96.0	0.0	-442.0	12.0	0.0	34.0	15.0
7001+50.00	7002+00.00	50.0	146.0	0.0	0.0	73.0	11.0	125.0	0.0	0.0	63.0	10.0	305.0	0.0	0.0	79.0	0.0	-180.0	0.0	0.0	-16.0	10.0
7002+00.00	7002+50.00	50.0	133.0	0.0	0.0	8.0	0.0	114.0	0.0	0.0	8.0	0.0	378.0	0.0	0.0	2.0	0.0	-264.0	0.0	0.0	4.0	0.0
7002+50.00	7003+00.00	50.0	35.0	0.0	0.0	25.0	0.0	30.0	0.0	0.0	22.0	0.0	868.0	0.0	0.0	5.0	0.0	-838.0	0.0	0.0	17.0	0.0
7003+00.00	7003+50.00	50.0	15.0	0.0	0.0	56.0	0.0	13.0	0.0	0.0	48.0	0.0	1349.0	0.0	0.0	3.0	0.0	-1336.0	0.0	0.0	45.0	0.0
7003+50.00	7004+00.00	50.0	11.0	0.0	0.0	67.0	0.0	10.0	0.0	0.0	57.0	0.0	1891.0	0.0	0.0	0.0	0.0	-1881.0	0.0	0.0	57.0	0.0
7004+00.00	7004+50.00	50.0	10.0	0.0	0.0	43.0	0.0	9.0	0.0	0.0	37.0	0.0	2279.0	0.0	0.0	0.0	0.0	-2270.0	0.0	0.0	37.0	0.0
7004+50.00	7005+00.00	50.0	23.0	0.0	0.0	13.0	0.0	20.0	0.0	0.0	12.0	0.0	2527.0	0.0	0.0	0.0	0.0	-2507.0	0.0	0.0	12.0	0.0
7005+00.00	7005+50.00	50.0	38.0	0.0	0.0	0.0	0.0	33.0	0.0	0.0	0.0	0.0	2851.0	0.0	0.0	0.0	0.0	-2818.0	0.0	0.0	0.0	0.0
7005+50.00	7006+00.00	50.0	49.0	0.0	0.0	0.0	0.0	42.0	0.0	0.0	0.0	0.0	3087.0	0.0	0.0	0.0	0.0	-3045.0	0.0	0.0	0.0	0.0
7006+00.00	7006+50.00	50.0	65.0	0.0	0.0	0.0	0.0	56.0	0.0	0.0	0.0	0.0	3133.0	0.0	0.0	0.0	0.0	-3077.0	0.0	0.0	0.0	0.0
7006+50.00	7007+00.00	50.0	90.0	0.0	0.0	0.0	0.0	77.0	0.0	0.0	0.0	0.0	2966.0	0.0	0.0	213.0	0.0	-2889.0	0.0	0.0	-213.0	0.0
7007+00.00	7007+50.00	50.0	53.0	0.0	0.0	0.0	0.0	46.0	0.0	0.0	0.0	0.0	2287.0	0.0	0.0	425.0	0.0	-2241.0	0.0	0.0	-425.0	0.0
7007+50.00	7008+00.00	50.0	0.0	0.0	0.0	0.0	0.0	0.0	0.0	0.0	0.0	0.0	1906.0	0.0	0.0	464.0	0.0	-1906.0	0.0	0.0	-464.0	0.0

MODEL: Default; FILE: \\benesch-pw-bentley.com\benesch\proj\62H15-sht-schedule-01.dgn



USER NAME = nReynolds  
 PLOT SCALE = 24,0000 "/ft.  
 PLOT DATE = 2/7/2022

DESIGNED -  
 DRAWN -  
 CHECKED -  
 DATE - 02/04/2022  
 REVISED -  
 REVISED -  
 REVISED -  
 REVISED -

**STATE OF ILLINOIS  
 DEPARTMENT OF TRANSPORTATION**

**SCHEDULE OF QUANTITIES  
 EARTHWORK**

SCALE: NO SCALE SHEET OF SHEETS STA. TO STA.

F.A./P. RTE.	SECTION	COUNTY	TOTAL SHEETS	SHEET NO.
*	2018-075-R	WILL	1510	68
CONTRACT NO. 62H15				
* FAI 55, FAP 338 ILLINOIS FED. AID PROJECT				

### EARTHWORK SCHEDULE OF QUANTITIES

STATION TO STATION		LENGTH (FT)	EARTH EXCAVATION					EARTH EXCAVATION ADJUSTED FOR SHRINKAGE (85%)					EMBANKMENT					EARTHWORK BALANCE WASTE				
			(FT)	(CUBIC YARDS)	(CUBIC YARDS)	(CUBIC YARDS)	(CUBIC YARDS)	(CUBIC YARDS)	(CUBIC YARDS)	(CUBIC YARDS)	(CUBIC YARDS)	(CUBIC YARDS)	(CUBIC YARDS)	(CUBIC YARDS)	(CUBIC YARDS)	(CUBIC YARDS)	(CUBIC YARDS)	(CUBIC YARDS)	(CUBIC YARDS)	(CUBIC YARDS)	(CUBIC YARDS)	
			STAGE 1	STAGE 1A	STAGE 2	STAGE 2A	STAGE 3	STAGE 1	STAGE 1A	STAGE 2	STAGE 2A	STAGE 3	STAGE 1	STAGE 1A	STAGE 2	STAGE 2A	STAGE 3	STAGE 1	STAGE 1A	STAGE 2	STAGE 2A	STAGE 3
7008+00.00	7008+50.00	50.0	0.0	0.0	0.0	0.0	0.0	0.0	0.0	0.0	0.0	2236.0	0.0	0.0	607.0	0.0	-2236.0	0.0	0.0	-607.0	0.0	
7008+50.00	7009+00.00	50.0	0.0	0.0	0.0	0.0	0.0	0.0	0.0	0.0	0.0	2474.0	0.0	0.0	831.0	0.0	-2474.0	0.0	0.0	-831.0	0.0	
7009+00.00	7009+50.00	50.0	0.0	0.0	0.0	0.0	0.0	0.0	0.0	0.0	0.0	1269.0	0.0	1678.0	684.0	0.0	-1269.0	0.0	-1678.0	-684.0	0.0	
7009+50.00	7010+00.00	50.0	0.0	0.0	0.0	0.0	0.0	0.0	0.0	0.0	0.0	0.0	0.0	3784.0	243.0	0.0	0.0	0.0	-3784.0	-243.0	0.0	
7010+00.00	7010+50.00	50.0	0.0	0.0	0.0	0.0	0.0	0.0	0.0	0.0	0.0	0.0	0.0	3984.0	37.0	0.0	0.0	0.0	-3984.0	-37.0	0.0	
7010+50.00	7011+00.00	50.0	0.0	0.0	0.0	0.0	0.0	0.0	0.0	0.0	0.0	0.0	0.0	3400.0	0.0	0.0	0.0	0.0	-3400.0	0.0	0.0	
7011+00.00	7011+50.00	50.0	0.0	0.0	0.0	0.0	0.0	0.0	0.0	0.0	0.0	0.0	0.0	3153.0	0.0	0.0	0.0	0.0	-3153.0	0.0	0.0	
7011+50.00	7012+00.00	50.0	0.0	0.0	0.0	0.0	0.0	0.0	0.0	0.0	0.0	0.0	0.0	2855.0	0.0	0.0	0.0	0.0	-2855.0	0.0	0.0	
7012+00.00	7012+50.00	50.0	0.0	0.0	0.0	0.0	0.0	0.0	0.0	0.0	0.0	0.0	0.0	2171.0	0.0	0.0	0.0	0.0	-2171.0	0.0	0.0	
7012+50.00	7013+00.00	50.0	0.0	0.0	0.0	0.0	0.0	0.0	0.0	0.0	0.0	0.0	0.0	1163.0	0.0	0.0	0.0	0.0	-1163.0	0.0	0.0	
7013+00.00	7013+50.00	50.0	0.0	0.0	28.0	0.0	0.0	0.0	0.0	24.0	0.0	0.0	0.0	408.0	0.0	0.0	0.0	0.0	-384.0	0.0	0.0	
7013+50.00	7014+00.00	50.0	0.0	0.0	28.0	69.0	0.0	0.0	0.0	24.0	59.0	0.0	0.0	191.0	260.0	0.0	0.0	0.0	-167.0	-201.0	0.0	
7014+00.00	7014+50.00	50.0	0.0	0.0	0.0	88.0	0.0	0.0	0.0	0.0	75.0	0.0	0.0	0.0	514.0	0.0	0.0	0.0	0.0	-439.0	0.0	
7014+50.00	7015+00.00	50.0	0.0	0.0	0.0	37.0	0.0	0.0	0.0	0.0	32.0	0.0	0.0	392.0	504.0	0.0	0.0	0.0	-392.0	-472.0	0.0	
7015+00.00	7015+50.00	50.0	0.0	0.0	0.0	32.0	0.0	0.0	0.0	0.0	28.0	0.0	0.0	622.0	444.0	0.0	0.0	0.0	-622.0	-416.0	0.0	
7015+50.00	7016+00.00	50.0	0.0	0.0	0.0	15.0	0.0	0.0	0.0	0.0	13.0	0.0	0.0	230.0	358.0	0.0	0.0	0.0	-230.0	-345.0	0.0	
7016+00.00	7016+50.00	50.0	0.0	0.0	0.0	0.0	0.0	0.0	0.0	0.0	0.0	0.0	0.0	163.0	0.0	0.0	0.0	0.0	0.0	-163.0	0.0	
7016+50.00	7017+00.00	50.0	0.0	0.0	0.0	0.0	0.0	0.0	0.0	0.0	0.0	0.0	0.0	0.0	0.0	0.0	0.0	0.0	0.0	0.0	0.0	
7017+00.00	7017+50.00	50.0	0.0	0.0	0.0	0.0	0.0	0.0	0.0	0.0	0.0	0.0	0.0	0.0	0.0	0.0	0.0	0.0	0.0	0.0	0.0	
7017+50.00	7018+00.00	50.0	0.0	0.0	0.0	0.0	0.0	0.0	0.0	0.0	0.0	0.0	0.0	0.0	0.0	0.0	0.0	0.0	0.0	0.0	0.0	
7018+00.00	7018+50.00	50.0	0.0	0.0	0.0	0.0	0.0	0.0	0.0	0.0	0.0	0.0	0.0	0.0	0.0	0.0	0.0	0.0	0.0	0.0	0.0	
7018+50.00	7019+00.00	50.0	0.0	0.0	0.0	0.0	0.0	0.0	0.0	0.0	0.0	0.0	0.0	0.0	0.0	0.0	0.0	0.0	0.0	0.0	0.0	
7019+00.00	7019+50.00	50.0	0.0	0.0	0.0	20.0	0.0	0.0	0.0	0.0	17.0	0.0	0.0	0.0	282.0	0.0	0.0	0.0	0.0	-265.0	0.0	
7019+50.00	7020+00.00	50.0	0.0	0.0	0.0	44.0	0.0	0.0	0.0	0.0	38.0	0.0	0.0	38.0	855.0	0.0	0.0	0.0	-38.0	-817.0	0.0	
7020+00.00	7020+50.00	50.0	0.0	0.0	0.0	36.0	0.0	0.0	0.0	0.0	31.0	0.0	0.0	38.0	1221.0	0.0	0.0	0.0	-38.0	-1190.0	0.0	
7020+50.00	7021+00.00	50.0	0.0	0.0	0.0	17.0	0.0	0.0	0.0	0.0	15.0	0.0	0.0	0.0	1335.0	0.0	0.0	0.0	0.0	-1320.0	0.0	
7021+00.00	7021+50.00	50.0	0.0	0.0	0.0	15.0	0.0	0.0	0.0	0.0	13.0	0.0	0.0	0.0	1610.0	0.0	0.0	0.0	0.0	-1597.0	0.0	
7021+50.00	7022+00.00	50.0	0.0	0.0	0.0	20.0	0.0	0.0	0.0	0.0	17.0	0.0	0.0	0.0	2099.0	0.0	0.0	0.0	0.0	-2082.0	0.0	
7022+00.00	7022+50.00	50.0	0.0	0.0	0.0	11.0	0.0	0.0	0.0	0.0	10.0	0.0	0.0	0.0	1540.0	0.0	0.0	0.0	0.0	-1530.0	0.0	
7022+50.00	7023+00.00	50.0	0.0	0.0	0.0	0.0	0.0	0.0	0.0	0.0	0.0	0.0	0.0	0.0	917.0	0.0	0.0	0.0	0.0	-917.0	0.0	
7023+00.00	7023+50.00	50.0	0.0	0.0	0.0	0.0	0.0	0.0	0.0	0.0	0.0	0.0	0.0	0.0	861.0	0.0	0.0	0.0	0.0	-861.0	0.0	
7023+50.00	7024+00.00	50.0	0.0	0.0	0.0	0.0	0.0	0.0	0.0	0.0	0.0	0.0	0.0	0.0	634.0	0.0	0.0	0.0	0.0	-634.0	0.0	
7024+00.00	7024+50.00	50.0	0.0	0.0	0.0	0.0	0.0	0.0	0.0	0.0	0.0	0.0	0.0	0.0	869.0	0.0	0.0	0.0	0.0	-869.0	0.0	
7024+50.00	7025+00.00	50.0	0.0	0.0	0.0	0.0	0.0	0.0	0.0	0.0	0.0	0.0	0.0	0.0	1407.0	0.0	0.0	0.0	0.0	-1407.0	0.0	
7025+00.00	7025+50.00	50.0	0.0	0.0	0.0	0.0	0.0	0.0	0.0	0.0	0.0	0.0	0.0	0.0	2243.0	0.0	0.0	0.0	0.0	-2243.0	0.0	
7025+50.00	7026+00.00	50.0	0.0	0.0	0.0	0.0	0.0	0.0	0.0	0.0	0.0	0.0	0.0	0.0	3320.0	0.0	0.0	0.0	0.0	-3320.0	0.0	
7026+00.00	7026+50.00	50.0	0.0	0.0	0.0	0.0	0.0	0.0	0.0	0.0	0.0	0.0	0.0	1551.0	1941.0	0.0	0.0	-1551.0	0.0	-1941.0	0.0	
7026+50.00	7027+00.00	50.0	0.0	0.0	0.0	0.0	0.0	0.0	0.0	0.0	0.0	0.0	0.0	3716.0	0.0	0.0	0.0	0.0	-3716.0	0.0	0.0	
7027+00.00	7027+50.00	50.0	1.0	0.0	0.0	7.0	0.0	0.0	0.0	0.0	6.0	0.0	0.0	3928.0	0.0	0.0	0.0	0.0	-3927.0	0.0	0.0	
7027+50.00	7028+00.00	50.0	1.0	0.0	0.0	7.0	0.0	0.0	0.0	0.0	6.0	0.0	0.0	3263.0	0.0	0.0	0.0	0.0	-3262.0	0.0	0.0	
7028+00.00	7028+50.00	50.0	10.0	0.0	0.0	0.0	0.0	0.0	0.0	0.0	9.0	0.0	0.0	2619.0	0.0	0.0	0.0	0.0	-2610.0	0.0	0.0	

D:\62H15\shl-schedule-05.dgn 50 107 2012/11/30



USER NAME = nReynolds  
PLOT SCALE = 24,0000 "/ft.  
PLOT DATE = 2/7/2022

DESIGNED -	REVISED -
DRAWN -	REVISED -
CHECKED -	REVISED -
DATE - 02/04/2022	REVISED -

**STATE OF ILLINOIS  
DEPARTMENT OF TRANSPORTATION**

**SCHEDULE OF QUANTITIES  
EARTHWORK**

SCALE: NO SCALE SHEET OF SHEETS STA. TO STA.

F.A./P.RTE.	SECTION	COUNTY	TOTAL SHEETS	SHEET NO.
*	2018-075-R	WILL	1510	69
				CONTRACT NO. 62H15
FAI 55, FAP 338	ILLINOIS	FED. AID PROJECT		

**EARTHWORK SCHEDULE OF QUANTITIES**

STATION TO STATION		LENGTH (FT)	EARTH EXCAVATION					EARTH EXCAVATION ADJUSTED FOR SHRINKAGE (85%)					EMBANKMENT					EARTHWORK BALANCE WASTE				
			(FT)	(CUBIC YARDS)	(CUBIC YARDS)	(CUBIC YARDS)	(CUBIC YARDS)	(CUBIC YARDS)	(CUBIC YARDS)	(CUBIC YARDS)	(CUBIC YARDS)	(CUBIC YARDS)	(CUBIC YARDS)	(CUBIC YARDS)	(CUBIC YARDS)	(CUBIC YARDS)	(CUBIC YARDS)	(CUBIC YARDS)	(CUBIC YARDS)	(CUBIC YARDS)	(CUBIC YARDS)	
			STAGE 1	STAGE 1A	STAGE 2	STAGE 2A	STAGE 3	STAGE 1	STAGE 1A	STAGE 2	STAGE 2A	STAGE 3	STAGE 1	STAGE 1A	STAGE 2	STAGE 2A	STAGE 3	STAGE 1	STAGE 1A	STAGE 2	STAGE 2A	STAGE 3
7028+50.00	7029+00.00	50.0	20.0	0.0	0.0	0.0	17.0	0.0	0.0	0.0	0.0	1942.0	0.0	0.0	0.0	0.0	-1925.0	0.0	0.0	0.0	0.0	
7029+00.00	7029+50.00	50.0	23.0	0.0	0.0	0.0	20.0	0.0	0.0	0.0	0.0	1433.0	0.0	0.0	0.0	0.0	-1413.0	0.0	0.0	0.0	0.0	
7029+50.00	7030+00.00	50.0	27.0	0.0	0.0	0.0	23.0	0.0	0.0	0.0	0.0	1037.0	0.0	0.0	0.0	0.0	-1014.0	0.0	0.0	0.0	0.0	
7030+00.00	7030+50.00	50.0	33.0	0.0	0.0	0.0	29.0	0.0	0.0	0.0	0.0	737.0	0.0	0.0	0.0	0.0	-708.0	0.0	0.0	0.0	0.0	
7030+50.00	7031+00.00	50.0	38.0	0.0	0.0	0.0	33.0	0.0	0.0	0.0	0.0	528.0	0.0	0.0	0.0	0.0	-495.0	0.0	0.0	0.0	0.0	
7031+00.00	7031+50.00	50.0	44.0	0.0	0.0	0.0	38.0	0.0	0.0	0.0	0.0	367.0	0.0	0.0	0.0	0.0	-329.0	0.0	0.0	0.0	0.0	
7031+50.00	7032+00.00	50.0	49.0	0.0	0.0	0.0	42.0	0.0	0.0	0.0	0.0	253.0	0.0	0.0	0.0	0.0	-211.0	0.0	0.0	0.0	0.0	
7032+00.00	7032+50.00	50.0	54.0	0.0	0.0	0.0	46.0	0.0	0.0	0.0	0.0	198.0	0.0	0.0	0.0	0.0	-152.0	0.0	0.0	0.0	0.0	
7032+50.00	7033+00.00	50.0	61.0	0.0	0.0	0.0	52.0	0.0	0.0	0.0	0.0	165.0	0.0	0.0	0.0	0.0	-113.0	0.0	0.0	0.0	0.0	
7033+00.00	7033+50.00	50.0	64.0	0.0	0.0	0.0	55.0	0.0	0.0	0.0	0.0	134.0	0.0	0.0	0.0	0.0	-79.0	0.0	0.0	0.0	0.0	
7033+50.00	7034+00.00	50.0	68.0	0.0	0.0	0.0	58.0	0.0	0.0	0.0	0.0	116.0	0.0	0.0	0.0	0.0	-58.0	0.0	0.0	0.0	0.0	
7034+00.00	7034+50.00	50.0	82.0	0.0	0.0	0.0	70.0	0.0	0.0	0.0	0.0	121.0	0.0	0.0	0.0	0.0	-51.0	0.0	0.0	0.0	0.0	
7034+50.00	7035+00.00	50.0	100.0	0.0	0.0	0.0	85.0	0.0	0.0	0.0	0.0	118.0	0.0	0.0	0.0	0.0	-33.0	0.0	0.0	0.0	0.0	
7035+00.00	7035+50.00	50.0	202.0	0.0	0.0	0.0	172.0	0.0	0.0	0.0	0.0	60.0	0.0	0.0	0.0	0.0	112.0	0.0	0.0	0.0	0.0	
7035+50.00	7036+00.00	50.0	343.0	0.0	0.0	0.0	292.0	0.0	0.0	0.0	0.0	13.0	0.0	0.0	0.0	0.0	279.0	0.0	0.0	0.0	0.0	
7036+00.00	7036+50.00	50.0	410.0	0.0	0.0	0.0	349.0	0.0	0.0	0.0	0.0	11.0	0.0	0.0	0.0	0.0	338.0	0.0	0.0	0.0	0.0	
7036+50.00	7037+00.00	50.0	436.0	0.0	0.0	0.0	371.0	0.0	0.0	0.0	0.0	24.0	0.0	0.0	0.0	0.0	347.0	0.0	0.0	0.0	0.0	
7037+00.00	7037+50.00	50.0	325.0	0.0	0.0	0.0	277.0	0.0	0.0	0.0	0.0	42.0	0.0	0.0	0.0	0.0	235.0	0.0	0.0	0.0	0.0	
<b>SUBTOTAL</b>			3097.0	233.0	56.0	1215.0	97.0	2648.0	199.0	48.0	1044.0	84.0	55583.0	38.0	24107.0	27253.0	0.0	-52935.0	161.0	-24059.0	-26209.0	84.0
<b>IL 59 NB</b>																						
8003+00.00	8003+50.00	50.0	89.0	0.0	0.0	164.0	0.0	76.0	0.0	0.0	140.0	0.0	737.0	0.0	0.0	77.0	0.0	-661.0	0.0	0.0	63.0	0.0
8003+50.00	8004+00.00	50.0	127.0	0.0	0.0	191.0	0.0	106.0	0.0	0.0	163.0	0.0	809.0	0.0	0.0	96.0	0.0	-701.0	0.0	0.0	67.0	0.0
8004+00.00	8004+50.00	50.0	144.0	0.0	0.0	223.0	0.0	123.0	0.0	0.0	190.0	0.0	784.0	0.0	0.0	117.0	0.0	-661.0	0.0	0.0	73.0	0.0
8004+50.00	8005+00.00	50.0	174.0	0.0	0.0	241.0	0.0	140.0	0.0	0.0	205.0	0.0	900.0	0.0	0.0	156.0	0.0	-660.0	0.0	0.0	49.0	0.0
8005+00.00	8005+50.00	50.0	166.0	0.0	0.0	188.0	0.0	142.0	0.0	0.0	160.0	0.0	899.0	0.0	0.0	226.0	0.0	-757.0	0.0	0.0	-66.0	0.0
8005+50.00	8006+00.00	50.0	132.0	0.0	0.0	125.0	0.0	113.0	0.0	0.0	107.0	0.0	938.0	0.0	0.0	337.0	0.0	-825.0	0.0	0.0	-230.0	0.0
8006+00.00	8006+50.00	50.0	113.0	0.0	0.0	86.0	0.0	97.0	0.0	0.0	74.0	0.0	924.0	0.0	0.0	430.0	0.0	-827.0	0.0	0.0	-356.0	0.0
8006+50.00	8007+00.00	50.0	108.0	0.0	0.0	38.0	0.0	92.0	0.0	0.0	33.0	0.0	855.0	0.0	0.0	505.0	0.0	-763.0	0.0	0.0	-472.0	0.0
8007+00.00	8007+50.00	50.0	123.0	0.0	0.0	10.0	0.0	105.0	0.0	0.0	9.0	0.0	741.0	0.0	0.0	630.0	0.0	-636.0	0.0	0.0	-621.0	0.0
8007+50.00	8008+00.00	50.0	145.0	0.0	0.0	7.0	0.0	124.0	0.0	0.0	6.0	0.0	565.0	0.0	0.0	789.0	0.0	-441.0	0.0	0.0	-783.0	0.0
8008+00.00	8008+50.00	50.0	136.0	0.0	0.0	21.0	0.0	116.0	0.0	0.0	18.0	0.0	336.0	0.0	0.0	964.0	0.0	-220.0	0.0	0.0	-946.0	0.0
8008+50.00	8009+00.00	50.0	150.0	0.0	0.0	37.0	0.0	128.0	0.0	0.0	32.0	0.0	112.0	0.0	0.0	1325.0	0.0	16.0	0.0	0.0	-1293.0	0.0
8009+00.00	8009+50.00	50.0	164.0	0.0	0.0	41.0	0.0	140.0	0.0	0.0	35.0	0.0	112.0	0.0	0.0	1751.0	0.0	28.0	0.0	0.0	-1716.0	0.0
8009+50.00	8010+00.00	50.0	71.0	0.0	0.0	64.0	0.0	61.0	0.0	0.0	55.0	0.0	107.0	0.0	213.0	2179.0	0.0	-46.0	0.0	-213.0	-2124.0	0.0
8010+00.00	8010+50.00	50.0	0.0	0.0	0.0	86.0	0.0	0.0	0.0	0.0	74.0	0.0	0.0	0.0	394.0	2204.0	0.0	0.0	0.0	-394.0	-2130.0	0.0
8010+50.00	8011+00.00	60.0	0.0	0.0	0.0	157.0	0.0	0.0	0.0	0.0	134.0	0.0	0.0	0.0	329.0	1390.0	0.0	0.0	0.0	-329.0	-1256.0	0.0
8011+00.00	8011+50.00	50.0	0.0	0.0	0.0	249.0	0.0	0.0	0.0	0.0	212.0	0.0	0.0	0.0	716.0	476.0	0.0	0.0	0.0	-716.0	-264.0	0.0
8011+50.00	8012+00.00	50.0	0.0	0.0	0.0	132.0	0.0	0.0	0.0	0.0	113.0	0.0	0.0	0.0	1333.0	66.0	0.0	0.0	0.0	-1333.0	47.0	0.0
8012+00.00	8012+50.00	50.0	0.0	0.0	0.0	0.0	0.0	0.0	0.0	0.0	0.0	0.0	0.0	0.0	1600.0	185.0	0.0	0.0	0.0	-1600.0	-185.0	0.0

MODEL: Default  
 FILE: AutoCAD  
 PROJECT: benesch-pro-bentley.com\benesch-01\Documents\10705\107140\_00\Eng\_Docs\_Phase II\General\62H115-shi-schedule-06.dgn  
 D:\62H115-shi-schedule-06.dgn  
 50 107  
 2012/11/30



USER NAME = nReynolds	DESIGNED -	REVISED -
PLOT SCALE = 24,0000 * / ft.	DRAWN -	REVISED -
PLOT DATE = 2/7/2022	CHECKED -	REVISED -
	DATE - 02/04/2022	REVISED -

**STATE OF ILLINOIS  
 DEPARTMENT OF TRANSPORTATION**

**SCHEDULE OF QUANTITIES  
 EARTHWORK**

SCALE: NO SCALE SHEET OF SHEETS STA. TO STA.

F.A./P. RTE. *	SECTION 2018-075-R	COUNTY WILL	TOTAL SHEETS 1510	SHEET NO. 70
FAI 55, FAP 338		ILLINOIS	FED. AID PROJECT	CONTRACT NO. 62H15



## EARTHWORK SCHEDULE OF QUANTITIES

STATION TO STATION		LENGTH (FT)	EARTH EXCAVATION					EARTH EXCAVATION ADJUSTED FOR SHRINKAGE (85%)					EMBANKMENT					EARTHWORK BALANCE WASTE				
			(FT)	(CUBIC YARDS)	(CUBIC YARDS)	(CUBIC YARDS)	(CUBIC YARDS)	(CUBIC YARDS)	(CUBIC YARDS)	(CUBIC YARDS)	(CUBIC YARDS)	(CUBIC YARDS)	(CUBIC YARDS)	(CUBIC YARDS)	(CUBIC YARDS)	(CUBIC YARDS)	(CUBIC YARDS)	(CUBIC YARDS)	(CUBIC YARDS)	(CUBIC YARDS)	(CUBIC YARDS)	
			STAGE 1	STAGE 1A	STAGE 2	STAGE 2A	STAGE 3	STAGE 1	STAGE 1A	STAGE 2	STAGE 2A	STAGE 3	STAGE 1	STAGE 1A	STAGE 2	STAGE 2A	STAGE 3	STAGE 1	STAGE 1A	STAGE 2	STAGE 2A	STAGE 3
904+00.00	904+50.00	50.0	183.0	0.0	21.0	0.0	0.0	156.0	0.0	18.0	0.0	0.0	276.0	0.0	250.0	0.0	0.0	-120.0	0.0	-232.0	0.0	0.0
904+50.00	905+00.00	50.0	379.0	0.0	11.0	0.0	0.0	323.0	0.0	10.0	0.0	0.0	328.0	0.0	297.0	0.0	0.0	-5.0	0.0	-287.0	0.0	0.0
905+00.00	905+50.00	50.0	407.0	0.0	0.0	0.0	0.0	346.0	0.0	0.0	0.0	0.0	274.0	0.0	333.0	0.0	0.0	72.0	0.0	-333.0	0.0	0.0
905+50.00	906+00.00	50.0	389.0	0.0	0.0	0.0	0.0	331.0	0.0	0.0	0.0	0.0	74.0	0.0	388.0	0.0	0.0	257.0	0.0	-388.0	0.0	0.0
906+00.00	906+50.00	50.0	365.0	0.0	0.0	0.0	0.0	311.0	0.0	0.0	0.0	0.0	42.0	0.0	446.0	0.0	0.0	269.0	0.0	-446.0	0.0	0.0
906+50.00	907+00.00	50.0	187.0	0.0	0.0	0.0	0.0	159.0	0.0	0.0	0.0	0.0	140.0	0.0	461.0	0.0	0.0	19.0	0.0	-461.0	0.0	0.0
907+00.00	907+50.00	50.0	0.0	0.0	0.0	0.0	0.0	0.0	0.0	0.0	0.0	0.0	173.0	0.0	508.0	0.0	0.0	-173.0	0.0	-508.0	0.0	0.0
907+50.00	908+00.00	50.0	158.0	0.0	0.0	0.0	0.0	135.0	0.0	0.0	0.0	0.0	188.0	0.0	555.0	0.0	0.0	-53.0	0.0	-555.0	0.0	0.0
908+00.00	908+50.00	50.0	299.0	0.0	0.0	0.0	0.0	255.0	0.0	0.0	0.0	0.0	222.0	0.0	555.0	0.0	0.0	33.0	0.0	-555.0	0.0	0.0
908+50.00	909+00.00	50.0	284.0	0.0	0.0	0.0	0.0	242.0	0.0	0.0	0.0	0.0	218.0	0.0	613.0	0.0	0.0	24.0	0.0	-613.0	0.0	0.0
909+00.00	909+50.00	50.0	294.0	0.0	0.0	0.0	0.0	250.0	0.0	0.0	0.0	0.0	309.0	0.0	714.0	0.0	0.0	-59.0	0.0	-714.0	0.0	0.0
909+50.00	910+00.00	50.0	363.0	0.0	0.0	0.0	0.0	309.0	0.0	0.0	0.0	0.0	353.0	0.0	788.0	0.0	0.0	-44.0	0.0	-788.0	0.0	0.0
910+00.00	910+50.00	50.0	475.0	0.0	0.0	0.0	0.0	404.0	0.0	0.0	0.0	0.0	360.0	0.0	881.0	0.0	0.0	44.0	0.0	-881.0	0.0	0.0
910+50.00	911+00.00	50.0	512.0	0.0	0.0	0.0	0.0	436.0	0.0	0.0	0.0	0.0	379.0	0.0	991.0	0.0	0.0	57.0	0.0	-991.0	0.0	0.0
911+00.00	911+50.00	50.0	517.0	0.0	0.0	0.0	0.0	440.0	0.0	0.0	0.0	0.0	421.0	0.0	1167.0	0.0	0.0	19.0	0.0	-1167.0	0.0	0.0
911+50.00	912+00.00	50.0	545.0	0.0	0.0	0.0	0.0	464.0	0.0	0.0	0.0	0.0	488.0	0.0	1439.0	0.0	0.0	-24.0	0.0	-1439.0	0.0	0.0
912+00.00	912+50.00	50.0	500.0	0.0	0.0	0.0	0.0	425.0	0.0	0.0	0.0	0.0	590.0	0.0	1738.0	0.0	0.0	-165.0	0.0	-1738.0	0.0	0.0
912+50.00	913+00.00	50.0	401.0	0.0	0.0	0.0	0.0	341.0	0.0	0.0	0.0	0.0	691.0	0.0	2030.0	0.0	0.0	-350.0	0.0	-2030.0	0.0	0.0
913+00.00	913+50.00	50.0	293.0	0.0	0.0	0.0	0.0	250.0	0.0	0.0	0.0	0.0	525.0	0.0	2527.0	0.0	0.0	-275.0	0.0	-2527.0	0.0	0.0
913+50.00	914+00.00	50.0	114.0	0.0	0.0	0.0	0.0	97.0	0.0	0.0	0.0	0.0	376.0	0.0	3202.0	0.0	0.0	-279.0	0.0	-3202.0	0.0	0.0
914+00.00	914+50.00	50.0	0.0	0.0	0.0	0.0	0.0	0.0	0.0	0.0	0.0	0.0	438.0	0.0	4277.0	0.0	0.0	-438.0	0.0	-4277.0	0.0	0.0
914+50.00	915+00.00	50.0	0.0	0.0	0.0	0.0	0.0	0.0	0.0	0.0	0.0	0.0	221.0	0.0	4436.0	688.0	0.0	-221.0	0.0	-4436.0	-688.0	0.0
915+00.00	915+50.00	50.0	0.0	0.0	16.0	0.0	0.0	0.0	0.0	14.0	0.0	0.0	0.0	0.0	4235.0	688.0	0.0	0.0	0.0	-4221.0	-688.0	0.0
915+50.00	916+00.00	50.0	0.0	0.0	16.0	6.0	0.0	0.0	0.0	14.0	6.0	0.0	0.0	0.0	2316.0	1815.0	0.0	0.0	0.0	-2302.0	-1809.0	0.0
916+00.00	916+50.00	50.0	0.0	0.0	0.0	25.0	0.0	0.0	0.0	0.0	22.0	0.0	0.0	0.0	0.0	3005.0	0.0	0.0	0.0	0.0	-2983.0	0.0
<b>SUBTOTAL</b>			6922.0	0.0	182.0	31.0	0.0	5895.0	0.0	158.0	28.0	0.0	8034.0	0.0	36089.0	6196.0	0.0	-2139.0	0.0	-35931.0	-6168.0	0.0
<b>RAMP B-N</b>																						
1105+50.00	1106+00.00	50.0	0.0	0.0	0.0	0.0	0.0	0.0	0.0	0.0	0.0	0.0	0.0	0.0	0.0	0.0	0.0	0.0	0.0	0.0	0.0	0.0
1106+00.00	1106+50.00	50.0	0.0	0.0	0.0	0.0	0.0	0.0	0.0	0.0	0.0	0.0	0.0	0.0	0.0	0.0	0.0	0.0	0.0	0.0	0.0	0.0
1106+50.00	1107+00.00	50.0	7.0	0.0	0.0	0.0	0.0	6.0	0.0	0.0	0.0	0.0	1536.0	0.0	0.0	0.0	0.0	-1530.0	0.0	0.0	0.0	0.0
1107+00.00	1107+50.00	50.0	23.0	0.0	0.0	0.0	0.0	20.0	0.0	0.0	0.0	0.0	3160.0	0.0	0.0	427.0	0.0	-3140.0	0.0	0.0	-427.0	0.0
1107+50.00	1108+00.00	50.0	36.0	0.0	0.0	0.0	0.0	31.0	0.0	0.0	0.0	0.0	4069.0	0.0	0.0	985.0	0.0	-4038.0	0.0	0.0	-985.0	0.0
1108+00.00	1108+50.00	50.0	42.0	0.0	0.0	0.0	0.0	36.0	0.0	0.0	0.0	0.0	4030.0	0.0	0.0	558.0	0.0	-3994.0	0.0	0.0	-558.0	0.0
1108+50.00	1109+00.00	50.0	45.0	0.0	0.0	0.0	0.0	39.0	0.0	0.0	0.0	0.0	2895.0	0.0	0.0	0.0	0.0	-2856.0	0.0	0.0	0.0	0.0
1109+00.00	1109+50.00	50.0	45.0	0.0	0.0	0.0	0.0	39.0	0.0	0.0	0.0	0.0	2345.0	0.0	0.0	0.0	0.0	-2306.0	0.0	0.0	0.0	0.0
1109+50.00	1110+00.00	60.0	40.0	0.0	0.0	0.0	0.0	34.0	0.0	0.0	0.0	0.0	2648.0	0.0	0.0	0.0	0.0	-2614.0	0.0	0.0	0.0	0.0
1110+00.00	1110+50.00	50.0	44.0	0.0	0.0	0.0	0.0	38.0	0.0	0.0	0.0	0.0	2920.0	0.0	0.0	0.0	0.0	-2882.0	0.0	0.0	0.0	0.0
1110+50.00	1111+00.00	50.0	51.0	0.0	0.0	0.0	0.0	44.0	0.0	0.0	0.0	0.0	2313.0	0.0	0.0	0.0	0.0	-2269.0	0.0	0.0	0.0	0.0
1111+00.00	1111+50.00	50.0	56.0	0.0	0.0	0.0	0.0	48.0	0.0	0.0	0.0	0.0	1837.0	0.0	0.0	0.0	0.0	-1789.0	0.0	0.0	0.0	0.0

MODEL: Default  
FILE: M:\15-benesch-ramp-by-combined-benefits\Documents\10705\107140\_001\Eng\_Docs\_Phase\_1\General\162H15-ht-schedule-08.dgn



USER NAME = nReynolds	DESIGNED -	REVISED -
PLOT SCALE = 24,0000' +/- ft.	DRAWN -	REVISED -
PLOT DATE = 2/7/2022	CHECKED -	REVISED -
	DATE = 02/04/2022	REVISED -

### STATE OF ILLINOIS DEPARTMENT OF TRANSPORTATION

### SCHEDULE OF QUANTITIES EARTHWORK

SCALE: NO SCALE SHEET OF SHEETS STA. TO STA.

F.A./P.RTE.	SECTION	COUNTY	TOTAL SHEETS	SHEET NO.
	2018-075-R	WILL	1510	72
CONTRACT NO. 62H15				
* FAI 55, FAP 338		ILLINOIS	FED. AID PROJECT	



**EARTHWORK SCHEDULE OF QUANTITIES**

STATION TO STATION	LENGTH (FT)	EARTH EXCAVATION					EARTH EXCAVATION ADJUSTED FOR SHRINKAGE (85%)					EMBANKMENT					EARTHWORK BALANCE WASTE						
	(FT)	(CUBIC YARDS)	(CUBIC YARDS)	(CUBIC YARDS)	(CUBIC YARDS)	(CUBIC YARDS)	(CUBIC YARDS)	(CUBIC YARDS)	(CUBIC YARDS)	(CUBIC YARDS)	(CUBIC YARDS)	(CUBIC YARDS)	(CUBIC YARDS)	(CUBIC YARDS)	(CUBIC YARDS)	(CUBIC YARDS)	(CUBIC YARDS)	(CUBIC YARDS)	(CUBIC YARDS)	(CUBIC YARDS)	(CUBIC YARDS)		
		STAGE 1	STAGE 1A	STAGE 2	STAGE 2A	STAGE 3	STAGE 1	STAGE 1A	STAGE 2	STAGE 2A	STAGE 3	STAGE 1	STAGE 1A	STAGE 2	STAGE 2A	STAGE 3	STAGE 1	STAGE 1A	STAGE 2	STAGE 2A	STAGE 3		
1111+50.00	1112+00.00	50.0	64.0	0.0	0.0	0.0	0.0	0.0	0.0	0.0	0.0	1480.0	0.0	0.0	0.0	0.0	-1425.0	0.0	0.0	0.0	0.0		
1112+00.00	1112+50.00	50.0	50.0	0.0	0.0	0.0	0.0	0.0	0.0	0.0	0.0	1259.0	0.0	0.0	0.0	0.0	-1216.0	0.0	0.0	0.0	0.0		
1112+50.00	1113+00.00	50.0	48.0	0.0	0.0	0.0	0.0	0.0	0.0	0.0	0.0	1150.0	0.0	0.0	0.0	0.0	-1109.0	0.0	0.0	0.0	0.0		
1113+00.00	1113+50.00	50.0	74.0	0.0	0.0	0.0	0.0	0.0	0.0	0.0	0.0	1024.0	0.0	0.0	0.0	0.0	-961.0	0.0	0.0	0.0	0.0		
1113+50.00	1114+00.00	50.0	78.0	0.0	0.0	0.0	0.0	0.0	0.0	0.0	0.0	900.0	0.0	0.0	0.0	0.0	-833.0	0.0	0.0	0.0	0.0		
1114+00.00	1114+50.00	50.0	67.0	0.0	0.0	0.0	0.0	0.0	0.0	0.0	0.0	760.0	0.0	0.0	0.0	0.0	-703.0	0.0	0.0	0.0	0.0		
1114+50.00	1115+00.00	50.0	54.0	0.0	0.0	0.0	0.0	0.0	0.0	0.0	0.0	625.0	0.0	0.0	0.0	0.0	-579.0	0.0	0.0	0.0	0.0		
1115+00.00	1115+50.00	50.0	30.0	0.0	0.0	0.0	0.0	0.0	0.0	0.0	0.0	504.0	0.0	0.0	0.0	0.0	-478.0	0.0	0.0	0.0	0.0		
1115+50.00	1116+00.00	50.0	20.0	0.0	0.0	0.0	0.0	0.0	0.0	0.0	0.0	300.0	0.0	0.0	0.0	0.0	-283.0	0.0	0.0	0.0	0.0		
1116+00.00	1116+50.00	50.0	30.0	0.0	0.0	0.0	0.0	0.0	0.0	0.0	0.0	138.0	0.0	0.0	0.0	0.0	-112.0	0.0	0.0	0.0	0.0		
1116+50.00	1117+00.00	50.0	35.0	0.0	0.0	0.0	0.0	0.0	0.0	0.0	0.0	92.0	0.0	0.0	0.0	0.0	-62.0	0.0	0.0	0.0	0.0		
1117+00.00	1117+50.00	50.0	27.0	0.0	0.0	0.0	0.0	0.0	0.0	0.0	0.0	48.0	0.0	0.0	0.0	0.0	-25.0	0.0	0.0	0.0	0.0		
1117+50.00	1118+00.00	50.0	102.0	0.0	0.0	0.0	0.0	0.0	0.0	0.0	0.0	57.0	0.0	0.0	0.0	0.0	30.0	0.0	0.0	0.0	0.0		
1118+00.00	1118+50.00	50.0	165.0	0.0	0.0	0.0	0.0	0.0	0.0	0.0	0.0	58.0	0.0	0.0	0.0	0.0	83.0	0.0	0.0	0.0	0.0		
1118+50.00	1119+00.00	50.0	134.0	0.0	0.0	0.0	0.0	0.0	0.0	0.0	0.0	114.0	0.0	0.0	0.0	0.0	88.0	0.0	0.0	0.0	0.0		
1119+00.00	1119+50.00	50.0	60.0	0.0	49.0	0.0	0.0	0.0	0.0	0.0	0.0	51.0	0.0	42.0	0.0	0.0	10.0	0.0	15.0	0.0	0.0		
1119+50.00	1120+00.00	50.0	0.0	0.0	100.0	0.0	0.0	0.0	0.0	0.0	0.0	0.0	0.0	85.0	0.0	0.0	0.0	0.0	34.0	0.0	0.0		
1120+00.00	1120+50.00	50.0	0.0	0.0	95.0	0.0	0.0	0.0	0.0	0.0	0.0	0.0	0.0	81.0	0.0	0.0	0.0	0.0	26.0	0.0	0.0		
1120+50.00	1121+00.00	50.0	0.0	0.0	99.0	0.0	0.0	0.0	0.0	0.0	0.0	0.0	0.0	85.0	0.0	0.0	0.0	0.0	9.0	0.0	0.0		
1121+00.00	1121+50.00	50.0	0.0	0.0	106.0	0.0	0.0	0.0	0.0	0.0	0.0	0.0	0.0	91.0	0.0	0.0	0.0	0.0	7.0	0.0	0.0		
1121+50.00	1122+00.00	50.0	0.0	0.0	109.0	0.0	0.0	0.0	0.0	0.0	0.0	0.0	0.0	93.0	0.0	0.0	0.0	0.0	13.0	0.0	0.0		
1122+00.00	1122+50.00	50.0	0.0	0.0	100.0	0.0	0.0	0.0	0.0	0.0	0.0	0.0	0.0	85.0	0.0	0.0	0.0	0.0	17.0	0.0	0.0		
1122+50.00	1123+00.00	50.0	0.0	0.0	79.0	0.0	0.0	0.0	0.0	0.0	0.0	0.0	0.0	68.0	0.0	0.0	0.0	0.0	19.0	0.0	0.0		
1123+00.00	1123+50.00	50.0	0.0	0.0	66.0	0.0	0.0	0.0	0.0	0.0	0.0	0.0	0.0	57.0	0.0	0.0	0.0	0.0	15.0	0.0	0.0		
1123+50.00	1124+00.00	50.0	0.0	0.0	56.0	0.0	0.0	0.0	0.0	0.0	0.0	0.0	0.0	48.0	0.0	0.0	0.0	0.0	12.0	0.0	0.0		
1124+00.00	1124+50.00	50.0	0.0	0.0	52.0	0.0	0.0	0.0	0.0	0.0	0.0	0.0	0.0	45.0	0.0	0.0	0.0	0.0	12.0	0.0	0.0		
1124+50.00	1125+00.00	50.0	0.0	0.0	49.0	0.0	0.0	0.0	0.0	0.0	0.0	0.0	0.0	42.0	0.0	0.0	0.0	0.0	28.0	0.0	0.0		
<b>SUBTOTAL</b>			1427.0	0.0	960.0	0.0	0.0	0.0	1222.0	0.0	822.0	0.0	0.0	36184.0	0.0	207.0	1970.0	0.0	-34962.0	0.0	615.0	-1970.0	0.0
<b>RAMP B-S</b>																							
1201+00.00	1201+50.00	50.0	0.0	0.0	0.0	0.0	0.0	0.0	0.0	0.0	0.0	0.0	0.0	0.0	0.0	0.0	0.0	0.0	0.0	0.0	0.0	0.0	
1201+50.00	1202+00.00	50.0	0.0	0.0	0.0	0.0	0.0	0.0	0.0	0.0	0.0	0.0	0.0	0.0	0.0	0.0	0.0	0.0	0.0	0.0	0.0	0.0	
1202+00.00	1202+50.00	50.0	0.0	0.0	0.0	0.0	0.0	0.0	0.0	0.0	0.0	0.0	0.0	0.0	0.0	0.0	0.0	0.0	0.0	0.0	0.0	0.0	
1202+50.00	1203+00.00	50.0	24.0	0.0	0.0	0.0	0.0	0.0	0.0	0.0	0.0	1253.0	0.0	0.0	0.0	33.0	0.0	-1232.0	0.0	0.0	0.0	-33.0	0.0
1203+00.00	1203+50.00	50.0	33.0	0.0	0.0	0.0	0.0	0.0	0.0	0.0	0.0	3342.0	0.0	0.0	0.0	306.0	0.0	-3313.0	0.0	0.0	0.0	-306.0	0.0
1203+50.00	1204+00.00	50.0	19.0	0.0	0.0	0.0	0.0	0.0	0.0	0.0	0.0	4716.0	0.0	0.0	0.0	274.0	0.0	-4699.0	0.0	0.0	0.0	-274.0	0.0
1204+00.00	1204+50.00	50.0	19.0	0.0	0.0	0.0	0.0	0.0	0.0	0.0	0.0	4564.0	0.0	0.0	0.0	0.0	0.0	-4547.0	0.0	0.0	0.0	0.0	0.0
1204+50.00	1205+00.00	50.0	19.0	0.0	0.0	0.0	0.0	0.0	0.0	0.0	0.0	3086.0	0.0	0.0	0.0	0.0	0.0	-3069.0	0.0	0.0	0.0	0.0	0.0
<b>SUBTOTAL</b>			114.0	0.0	0.0	0.0	0.0	0.0	101.0	0.0	0.0	0.0	0.0	16961.0	0.0	0.0	613.0	0.0	-16860.0	0.0	0.0	-613.0	0.0

MODEL: Default  
 FILE: \\benesch-pw-bentley.com\benesch-pw\01\Documents\1120205\10140\_00\Eng\_Docs\_Phase 1\General\11202115-sht-schedule-09.dgn  
 D:\62H15-sht-schedule-09.dgn  
 50107  
 2012/11/30



USER NAME = nReynolds	DESIGNED -	REVISED -
PLOT SCALE = 24,0000' = 1 / ft.	DRAWN -	REVISED -
PLOT DATE = 2/7/2022	CHECKED -	REVISED -
	DATE - 02/04/2022	REVISED -

**STATE OF ILLINOIS  
DEPARTMENT OF TRANSPORTATION**

**SCHEDULE OF QUANTITIES  
EARTHWORK**

SCALE: NO SCALE SHEET OF SHEETS STA. TO STA.

F.A./P RTE.	SECTION	COUNTY	TOTAL SHEETS	SHEET NO.
FAI 55, FAP 338	2018-075-R	WILL	1510	73
CONTRACT NO. 62H15				

ILLINOIS FED. AID PROJECT

EARTHWORK SCHEDULE OF QUANTITIES

Table with columns for STATION TO STATION, LENGTH (FT), EARTH EXCAVATION, EARTH EXCAVATION ADJUSTED FOR SHRINKAGE (85%), EMBANKMENT, and EARTHWORK BALANCE WASTE. Includes subtotals for RAMP C-N and RAMP D-N.

MODEL: Default; FILE: Mod\Benech\proj\benesch-aw-bentley.com\benesch-aw-01\Documents\107005\10740\_001\Eng\_Docs\_Phas\_1\General\162H15-shi-schedule-10.dgn



USER NAME = nReynolds; PLOT SCALE = 24,0000 \*/ ft.; PLOT DATE = 2/7/2022

DESIGNED - DRAWN - CHECKED - DATE - 02/04/2022

REVISED - REVISED - REVISED - REVISED -

STATE OF ILLINOIS DEPARTMENT OF TRANSPORTATION

SCHEDULE OF QUANTITIES EARTHWORK

SCALE: NO SCALE SHEET OF SHEETS STA. TO STA.

Table with columns for F.A./P.RTE., SECTION (2018-075-R), COUNTY (WILL), TOTAL SHEETS (1510), SHEET NO. (74), and CONTRACT NO. (62H15).

D:\62H15-shi-schedule-10.dgn 50107 2012/11/30



**EARTHWORK SCHEDULE OF QUANTITIES**

STATION TO STATION		LENGTH (FT)	EARTH EXCAVATION					EARTH EXCAVATION ADJUSTED FOR SHRINKAGE (85%)					EMBANKMENT					EARTHWORK BALANCE WASTE				
			(FT)	(CUBIC YARDS)	(CUBIC YARDS)	(CUBIC YARDS)	(CUBIC YARDS)	(CUBIC YARDS)	(CUBIC YARDS)	(CUBIC YARDS)	(CUBIC YARDS)	(CUBIC YARDS)	(CUBIC YARDS)	(CUBIC YARDS)	(CUBIC YARDS)	(CUBIC YARDS)	(CUBIC YARDS)	(CUBIC YARDS)	(CUBIC YARDS)	(CUBIC YARDS)	(CUBIC YARDS)	
			STAGE 1	STAGE 1A	STAGE 2	STAGE 2A	STAGE 3	STAGE 1	STAGE 1A	STAGE 2	STAGE 2A	STAGE 3	STAGE 1	STAGE 1A	STAGE 2	STAGE 2A	STAGE 3	STAGE 1	STAGE 1A	STAGE 2	STAGE 2A	STAGE 3
<b>SEIL ROAD</b>																						
4003+50.00	4004+00.00	50.0	0.0	0.0	12.0	5.0	9.0	0.0	0.0	11.0	5.0	8.0	0.0	0.0	0.0	0.0	11.0	0.0	0.0	11.0	5.0	-3.0
4004+00.00	4004+50.00	50.0	0.0	0.0	25.0	11.0	14.0	0.0	0.0	22.0	10.0	12.0	0.0	0.0	2.0	0.0	19.0	0.0	0.0	20.0	10.0	-7.0
4004+50.00	4005+00.00	50.0	0.0	0.0	25.0	13.0	12.0	0.0	0.0	22.0	12.0	11.0	0.0	0.0	5.0	0.0	17.0	0.0	0.0	17.0	12.0	-6.0
4005+00.00	4005+50.00	50.0	0.0	0.0	27.0	14.0	16.0	0.0	0.0	23.0	12.0	14.0	0.0	0.0	3.0	0.0	14.0	0.0	0.0	20.0	12.0	0.0
4005+50.00	4006+00.00	50.0	0.0	0.0	24.0	16.0	19.0	0.0	0.0	21.0	14.0	17.0	0.0	0.0	4.0	0.0	13.0	0.0	0.0	17.0	14.0	4.0
4006+00.00	4006+50.00	50.0	0.0	0.0	24.0	16.0	19.0	0.0	0.0	21.0	14.0	17.0	0.0	0.0	7.0	0.0	12.0	0.0	0.0	14.0	14.0	5.0
4006+50.00	4007+00.00	50.0	0.0	0.0	42.0	15.0	22.0	0.0	0.0	36.0	13.0	19.0	0.0	0.0	3.0	0.0	9.0	0.0	0.0	33.0	13.0	10.0
4007+00.00	4007+50.00	50.0	0.0	0.0	46.0	15.0	21.0	0.0	0.0	40.0	13.0	18.0	0.0	0.0	3.0	0.0	8.0	0.0	0.0	37.0	13.0	10.0
4007+50.00	4008+00.00	50.0	0.0	0.0	63.0	18.0	16.0	0.0	0.0	54.0	16.0	14.0	0.0	0.0	3.0	0.0	6.0	0.0	0.0	51.0	16.0	8.0
4008+00.00	4008+50.00	50.0	0.0	0.0	72.0	23.0	23.0	0.0	0.0	62.0	20.0	20.0	0.0	0.0	0.0	0.0	2.0	0.0	0.0	62.0	20.0	18.0
4008+50.00	4009+00.00	50.0	0.0	0.0	73.0	26.0	30.0	0.0	0.0	63.0	23.0	26.0	0.0	0.0	0.0	0.0	0.0	0.0	0.0	63.0	23.0	26.0
4009+00.00	4009+50.00	50.0	0.0	0.0	102.0	27.0	26.0	0.0	0.0	87.0	23.0	23.0	0.0	0.0	0.0	0.0	1.0	0.0	0.0	87.0	23.0	22.0
4009+50.00	4010+00.00	50.0	0.0	23.0	58.0	20.0	35.0	0.0	20.0	50.0	17.0	30.0	0.0	34.0	0.0	0.0	8.0	0.0	-14.0	50.0	17.0	22.0
4010+00.00	4010+50.00	50.0	0.0	38.0	0.0	7.0	52.0	0.0	33.0	0.0	6.0	45.0	0.0	34.0	0.0	0.0	11.0	0.0	-1.0	0.0	6.0	34.0
4010+50.00	4011+00.00	50.0	0.0	16.0	0.0	5.0	44.0	0.0	14.0	0.0	5.0	38.0	0.0	0.0	0.0	0.0	4.0	0.0	14.0	0.0	5.0	34.0
4011+00.00	4011+50.00	50.0	0.0	0.0	0.0	14.0	25.0	0.0	0.0	0.0	12.0	22.0	0.0	0.0	0.0	0.0	13.0	0.0	0.0	0.0	12.0	9.0
4011+50.00	4012+00.00	50.0	0.0	0.0	62.0	20.0	25.0	0.0	0.0	53.0	17.0	22.0	0.0	0.0	0.0	0.0	56.0	0.0	0.0	53.0	17.0	-34.0
4012+00.00	4012+50.00	50.0	0.0	0.0	94.0	22.0	25.0	0.0	0.0	80.0	19.0	22.0	0.0	0.0	0.0	0.0	73.0	0.0	0.0	80.0	19.0	-51.0
4012+50.00	4013+00.00	50.0	7.0	0.0	66.0	25.0	13.0	6.0	0.0	57.0	22.0	12.0	66.0	0.0	19.0	0.0	30.0	-60.0	0.0	38.0	22.0	-18.0
4013+00.00	4013+50.00	50.0	16.0	0.0	60.0	31.0	0.0	14.0	0.0	68.0	27.0	0.0	143.0	0.0	36.0	0.0	0.0	-129.0	0.0	32.0	27.0	0.0
4013+50.00	4014+00.00	50.0	25.0	0.0	88.0	32.0	0.0	22.0	0.0	75.0	28.0	0.0	179.0	0.0	44.0	0.0	0.0	-157.0	0.0	31.0	28.0	0.0
4014+00.00	4014+50.00	50.0	18.0	0.0	60.0	20.0	0.0	16.0	0.0	51.0	17.0	0.0	320.0	0.0	42.0	0.0	0.0	-304.0	0.0	9.0	17.0	0.0
4014+50.00	4015+00.00	50.0	5.0	0.0	37.0	11.0	0.0	5.0	0.0	32.0	10.0	0.0	520.0	0.0	37.0	0.0	0.0	-515.0	0.0	-5.0	10.0	0.0
4015+00.00	4015+50.00	50.0	3.0	0.0	31.0	10.0	0.0	3.0	0.0	27.0	9.0	0.0	693.0	0.0	25.0	0.0	0.0	-690.0	0.0	2.0	9.0	0.0
4015+50.00	4016+00.00	50.0	1.0	0.0	29.0	5.0	0.0	1.0	0.0	25.0	5.0	0.0	857.0	0.0	117.0	0.0	0.0	-856.0	0.0	-92.0	5.0	0.0
4016+00.00	4016+50.00	50.0	5.0	18.0	16.0	2.0	0.0	5.0	16.0	14.0	2.0	0.0	1042.0	142.0	113.0	0.0	0.0	-1037.0	-126.0	-99.0	2.0	0.0
4016+50.00	4017+00.00	50.0	5.0	35.0	0.0	2.0	0.0	5.0	30.0	0.0	2.0	0.0	1219.0	281.0	0.0	0.0	0.0	-1214.0	-251.0	0.0	2.0	0.0
4017+00.00	4017+50.00	50.0	0.0	38.0	0.0	0.0	0.0	0.0	33.0	0.0	0.0	0.0	1251.0	148.0	0.0	0.0	0.0	-1251.0	-115.0	0.0	0.0	0.0
<b>SUBTOTAL</b>			85.0	168.0	1158.0	425.0	448.0	77.0	146.0	994.0	373.0	390.0	6290.0	639.0	463.0	0.0	307.0	-6213.0	-493.0	531.0	373.0	83.0
<b>WEST FRONTAGE ROAD</b>																						
5540+00.00	5540+50.00	50.0	0.0	4.0	11.0	0.0	0.0	4.0	10.0	0.0	0.0	0.0	11.0	19.0	0.0	0.0	0.0	-7.0	-9.0	0.0	0.0	
5540+50.00	5541+00.00	50.0	0.0	46.0	23.0	0.0	0.0	0.0	40.0	20.0	0.0	0.0	21.0	37.0	0.0	0.0	0.0	19.0	-17.0	0.0	0.0	
5541+00.00	5541+50.00	50.0	0.0	75.0	29.0	0.0	0.0	0.0	64.0	25.0	0.0	0.0	19.0	35.0	0.0	0.0	0.0	45.0	-10.0	0.0	0.0	
5541+50.00	5542+00.00	60.0	0.0	74.0	23.0	0.0	0.0	0.0	63.0	20.0	0.0	0.0	15.0	52.0	0.0	0.0	0.0	48.0	-32.0	0.0	0.0	
5542+00.00	5542+50.00	50.0	0.0	81.0	78.0	0.0	0.0	0.0	69.0	67.0	0.0	0.0	15.0	52.0	0.0	0.0	0.0	54.0	15.0	0.0	0.0	
5542+50.00	5543+00.00	50.0	0.0	79.0	148.0	0.0	0.0	0.0	68.0	126.0	0.0	0.0	16.0	35.0	0.0	0.0	0.0	52.0	91.0	0.0	0.0	
5543+00.00	5543+50.00	50.0	0.0	76.0	147.0	0.0	0.0	0.0	65.0	125.0	0.0	0.0	15.0	18.0	0.0	0.0	0.0	50.0	107.0	0.0	0.0	
5543+50.00	5544+00.00	50.0	0.0	74.0	164.0	0.0	0.0	0.0	63.0	140.0	0.0	0.0	8.0	19.0	0.0	0.0	0.0	55.0	121.0	0.0	0.0	
5544+00.00	5544+50.00	50.0	0.0	36.0	104.0	0.0	0.0	0.0	31.0	89.0	0.0	0.0	0.0	38.0	0.0	0.0	0.0	31.0	51.0	0.0	0.0	
<b>SUBTOTAL</b>			0.0	545.0	727.0	0.0	0.0	0.0	467.0	622.0	0.0	0.0	0.0	120.0	305.0	0.0	0.0	0.0	347.0	317.0	0.0	0.0

MODEL: Default  
 FILE: M:\AEC\AutoCAD\benesch\pub\benesch-nw\benesch-nw\benesch-nw\15-shi-schedule-12.dgn  
 D:\62H15-shi-schedule-12.dgn  
 50 107  
 2012/11/30



USER NAME = nReynolds  
 PLOT SCALE = 24.0000 \* / ft.  
 PLOT DATE = 2/7/2022

DESIGNED -  
 DRAWN -  
 CHECKED -  
 DATE = 02/04/2022

REVISED -  
 REVISED -  
 REVISED -  
 REVISED -

**STATE OF ILLINOIS  
 DEPARTMENT OF TRANSPORTATION**

**SCHEDULE OF QUANTITIES  
 EARTHWORK**

SCALE: NO SCALE SHEET OF SHEETS STA. TO STA.

F.A./P RTE.	SECTION	COUNTY	TOTAL SHEETS	SHEET NO.
*	2018-075-R	WILL	1510	76
CONTRACT NO. 62H15				

FAI 55, FAP 338 ILLINOIS FED. AID PROJECT

**EARTHWORK SCHEDULE OF QUANTITIES**

STATION TO STATION	LENGTH (FT)	EARTH EXCAVATION					EARTH EXCAVATION ADJUSTED FOR SHRINKAGE (85%)					EMBANKMENT					EARTHWORK BALANCE WASTE					
		(FT)	(CUBIC YARDS)	(CUBIC YARDS)	(CUBIC YARDS)	(CUBIC YARDS)	(CUBIC YARDS)	(CUBIC YARDS)	(CUBIC YARDS)	(CUBIC YARDS)	(CUBIC YARDS)	(CUBIC YARDS)	(CUBIC YARDS)	(CUBIC YARDS)	(CUBIC YARDS)	(CUBIC YARDS)	(CUBIC YARDS)	(CUBIC YARDS)	(CUBIC YARDS)	(CUBIC YARDS)	(CUBIC YARDS)	
		STAGE 1	STAGE 1A	STAGE 2	STAGE 2A	STAGE 3	STAGE 1	STAGE 1A	STAGE 2	STAGE 2A	STAGE 3	STAGE 1	STAGE 1A	STAGE 2	STAGE 2A	STAGE 3	STAGE 1	STAGE 1A	STAGE 2	STAGE 2A	STAGE 3	
<b>ROCK RUN CROSSINGS DR</b>																						
6060+00.00	6060+50.00	50.0	87.0	0.0	0.0	0.0	74.0	0.0	0.0	0.0	0.0	16.0	0.0	0.0	0.0	0.0	58.0	0.0	0.0	0.0	0.0	
6060+50.00	6061+00.00	50.0	105.0	0.0	0.0	0.0	90.0	0.0	0.0	0.0	0.0	9.0	0.0	0.0	0.0	0.0	81.0	0.0	0.0	0.0	0.0	
6061+00.00	6061+50.00	50.0	132.0	0.0	0.0	0.0	113.0	0.0	0.0	0.0	0.0	7.0	0.0	0.0	0.0	0.0	106.0	0.0	0.0	0.0	0.0	
6061+50.00	6062+00.00	50.0	129.0	0.0	0.0	0.0	110.0	0.0	0.0	0.0	0.0	6.0	0.0	0.0	0.0	0.0	104.0	0.0	0.0	0.0	0.0	
6062+00.00	6062+50.00	50.0	131.0	0.0	0.0	0.0	112.0	0.0	0.0	0.0	0.0	10.0	0.0	0.0	0.0	0.0	102.0	0.0	0.0	0.0	0.0	
6062+50.00	6063+00.00	50.0	129.0	0.0	0.0	0.0	110.0	0.0	0.0	0.0	0.0	14.0	0.0	0.0	0.0	0.0	96.0	0.0	0.0	0.0	0.0	
6063+00.00	6063+50.00	50.0	123.0	0.0	0.0	0.0	105.0	0.0	0.0	0.0	0.0	11.0	0.0	0.0	0.0	0.0	94.0	0.0	0.0	0.0	0.0	
6063+50.00	6064+00.00	50.0	118.0	0.0	0.0	0.0	101.0	0.0	0.0	0.0	0.0	9.0	0.0	0.0	0.0	0.0	92.0	0.0	0.0	0.0	0.0	
6064+00.00	6064+50.00	50.0	113.0	0.0	0.0	0.0	97.0	0.0	0.0	0.0	0.0	7.0	0.0	0.0	0.0	0.0	90.0	0.0	0.0	0.0	0.0	
6064+50.00	6065+00.00	50.0	105.0	0.0	0.0	0.0	90.0	0.0	0.0	0.0	0.0	6.0	0.0	0.0	0.0	0.0	84.0	0.0	0.0	0.0	0.0	
6065+00.00	6065+50.00	50.0	84.0	0.0	0.0	0.0	72.0	0.0	0.0	0.0	0.0	14.0	0.0	0.0	0.0	0.0	58.0	0.0	0.0	0.0	0.0	
6065+50.00	6066+00.00	50.0	60.0	0.0	0.0	0.0	51.0	0.0	0.0	0.0	0.0	23.0	0.0	0.0	0.0	0.0	28.0	0.0	0.0	0.0	0.0	
6066+00.00	6066+50.00	50.0	49.0	0.0	0.0	0.0	42.0	0.0	0.0	0.0	0.0	24.0	0.0	0.0	0.0	0.0	18.0	0.0	0.0	0.0	0.0	
6066+50.00	6067+00.00	50.0	44.0	0.0	0.0	0.0	38.0	0.0	0.0	0.0	0.0	24.0	0.0	0.0	0.0	0.0	14.0	0.0	0.0	0.0	0.0	
6067+00.00	6067+50.00	50.0	45.0	0.0	0.0	0.0	39.0	0.0	0.0	0.0	0.0	25.0	0.0	0.0	0.0	0.0	14.0	0.0	0.0	0.0	0.0	
6067+50.00	6068+00.00	50.0	49.0	0.0	0.0	0.0	42.0	0.0	0.0	0.0	0.0	25.0	0.0	0.0	0.0	0.0	17.0	0.0	0.0	0.0	0.0	
6068+00.00	6068+50.00	50.0	47.0	0.0	0.0	0.0	40.0	0.0	0.0	0.0	0.0	24.0	0.0	0.0	0.0	0.0	16.0	0.0	0.0	0.0	0.0	
6068+50.00	6069+00.00	50.0	48.0	0.0	0.0	0.0	41.0	0.0	0.0	0.0	0.0	22.0	0.0	0.0	0.0	0.0	19.0	0.0	0.0	0.0	0.0	
6069+00.00	6069+50.00	50.0	53.0	0.0	0.0	0.0	46.0	0.0	0.0	0.0	0.0	22.0	0.0	0.0	0.0	0.0	24.0	0.0	0.0	0.0	0.0	
6069+50.00	6070+00.00	50.0	50.0	0.0	0.0	0.0	43.0	0.0	0.0	0.0	0.0	23.0	0.0	0.0	0.0	0.0	20.0	0.0	0.0	0.0	0.0	
6070+00.00	6070+50.00	50.0	33.0	0.0	0.0	0.0	29.0	0.0	0.0	0.0	0.0	31.0	0.0	0.0	0.0	0.0	-2.0	0.0	0.0	0.0	0.0	
6070+50.00	6071+00.00	50.0	12.0	0.0	0.0	0.0	11.0	0.0	0.0	0.0	0.0	43.0	0.0	0.0	0.0	0.0	-32.0	0.0	0.0	0.0	0.0	
6071+00.00	6071+50.00	50.0	1.0	0.0	0.0	0.0	1.0	0.0	0.0	0.0	0.0	50.0	0.0	0.0	0.0	0.0	-49.0	0.0	0.0	0.0	0.0	
6071+50.00	6072+00.00	50.0	0.0	0.0	0.0	0.0	0.0	0.0	0.0	0.0	0.0	69.0	0.0	0.0	0.0	0.0	-69.0	0.0	0.0	0.0	0.0	
6072+00.00	6072+50.00	50.0	0.0	0.0	0.0	0.0	0.0	0.0	0.0	0.0	0.0	100.0	0.0	0.0	0.0	0.0	-100.0	0.0	0.0	0.0	0.0	
6072+50.00	6073+00.00	50.0	0.0	0.0	0.0	0.0	0.0	0.0	0.0	0.0	0.0	122.0	0.0	0.0	0.0	0.0	-122.0	0.0	0.0	0.0	0.0	
6073+00.00	6073+50.00	50.0	0.0	0.0	0.0	0.0	0.0	0.0	0.0	0.0	0.0	133.0	0.0	0.0	0.0	0.0	-133.0	0.0	0.0	0.0	0.0	
6073+50.00	6074+00.00	50.0	0.0	0.0	0.0	0.0	0.0	0.0	0.0	0.0	0.0	127.0	0.0	0.0	0.0	0.0	-127.0	0.0	0.0	0.0	0.0	
6074+00.00	6074+50.00	50.0	0.0	0.0	0.0	0.0	0.0	0.0	0.0	0.0	0.0	102.0	0.0	0.0	0.0	0.0	-102.0	0.0	0.0	0.0	0.0	
6074+50.00	6075+00.00	50.0	0.0	0.0	0.0	0.0	0.0	0.0	0.0	0.0	0.0	78.0	0.0	0.0	0.0	0.0	-78.0	0.0	0.0	0.0	0.0	
6075+00.00	6075+50.00	50.0	0.0	0.0	0.0	0.0	0.0	0.0	0.0	0.0	0.0	72.0	0.0	0.0	0.0	0.0	-72.0	0.0	0.0	0.0	0.0	
6075+50.00	6076+00.00	50.0	0.0	0.0	0.0	0.0	0.0	0.0	0.0	0.0	0.0	71.0	0.0	0.0	0.0	0.0	-71.0	0.0	0.0	0.0	0.0	
6076+00.00	6076+50.00	50.0	0.0	0.0	0.0	0.0	0.0	0.0	0.0	0.0	0.0	61.0	0.0	0.0	0.0	0.0	-61.0	0.0	0.0	0.0	0.0	
6076+50.00	6077+00.00	50.0	0.0	0.0	0.0	0.0	0.0	0.0	0.0	0.0	0.0	67.0	0.0	0.0	0.0	0.0	-67.0	0.0	0.0	0.0	0.0	
6077+00.00	6077+50.00	50.0	0.0	0.0	0.0	0.0	0.0	0.0	0.0	0.0	0.0	97.0	0.0	0.0	0.0	0.0	-97.0	0.0	0.0	0.0	0.0	
6077+50.00	6078+00.00	60.0	0.0	0.0	0.0	0.0	0.0	0.0	0.0	0.0	0.0	128.0	0.0	0.0	0.0	0.0	-128.0	0.0	0.0	0.0	0.0	
6078+00.00	6078+50.00	50.0	2.0	0.0	0.0	0.0	2.0	0.0	0.0	0.0	0.0	159.0	0.0	0.0	0.0	0.0	-157.0	0.0	0.0	0.0	0.0	
6078+50.00	6079+00.00	50.0	5.0	0.0	0.0	0.0	5.0	0.0	0.0	0.0	0.0	190.0	0.0	0.0	0.0	0.0	-185.0	0.0	0.0	0.0	0.0	
6079+00.00	6079+50.00	50.0	8.0	0.0	0.0	0.0	7.0	0.0	0.0	0.0	0.0	260.0	0.0	0.0	0.0	0.0	-253.0	0.0	0.0	0.0	0.0	
6079+50.00	6080+00.00	50.0	12.0	0.0	0.0	0.0	11.0	0.0	0.0	0.0	0.0	306.0	0.0	0.0	0.0	0.0	-295.0	0.0	0.0	0.0	0.0	
6080+00.00	6080+50.00	50.0	13.0	0.0	0.0	0.0	12.0	0.0	0.0	0.0	0.0	316.0	0.0	0.0	0.0	0.0	-304.0	0.0	0.0	0.0	0.0	
6080+50.00	6081+00.00	50.0	13.0	0.0	0.0	0.0	12.0	0.0	0.0	0.0	0.0	358.0	0.0	0.0	0.0	0.0	-346.0	0.0	0.0	0.0	0.0	
6081+00.00	6081+50.00	50.0	12.0	0.0	0.0	0.0	11.0	0.0	0.0	0.0	0.0	387.0	0.0	0.0	0.0	0.0	-376.0	0.0	0.0	0.0	0.0	
6081+50.00	6082+00.00	50.0	11.0	0.0	0.0	0.0	10.0	0.0	0.0	0.0	0.0	374.0	0.0	0.0	0.0	0.0	-364.0	0.0	0.0	0.0	0.0	
6082+00.00	6082+50.00	50.0	13.0	0.0	0.0	0.0	12.0	0.0	0.0	0.0	0.0	308.0	0.0	0.0	0.0	0.0	-296.0	0.0	0.0	0.0	0.0	
6082+50.00	6083+00.00	50.0	9.0	0.0	0.0	0.0	8.0	0.0	0.0	0.0	0.0	227.0	0.0	0.0	0.0	0.0	-219.0	0.0	0.0	0.0	0.0	
6083+00.00	6083+50.00	50.0	0.0	0.0	0.0	0.0	0.0	0.0	0.0	0.0	0.0	155.0	0.0	0.0	0.0	0.0	-155.0	0.0	0.0	0.0	0.0	
6083+50.00	6084+00.00	50.0	0.0	0.0	0.0	0.0	0.0	0.0	0.0	0.0	0.0	101.0	0.0	0.0	0.0	0.0	-101.0	0.0	0.0	0.0	0.0	
6084+00.00	6084+50.00	50.0	0.0	0.0	0.0	0.0	0.0	0.0	0.0	0.0	0.0	74.0	0.0	0.0	0.0	0.0	-74.0	0.0	0.0	0.0	0.0	
6084+50.00	6085+00.00	50.0	0.0	0.0	0.0	0.0	0.0	0.0	0.0	0.0	0.0	47.0	0.0	0.0	0.0	0.0	-47.0	0.0	0.0	0.0	0.0	

MODEL: Default  
 FILE: M:\IPL\benesch-arj\_bentley.com\benesch-arj\Documents\107005\10740\_00\Eng\_Docx\_Phase\_II\General\62H15-RS-schedule-13.dgn  
 D:\62H15-RS-schedule-13.dgn  
 50.107  
 2012/11/30



USER NAME = nReynolds	DESIGNED -	REVISED -
PLOT SCALE = 24.0000 * / ft.	DRAWN -	

### EARTHWORK SCHEDULE OF QUANTITIES

STATION TO STATION		LENGTH (FT)	EARTH EXCAVATION					EARTH EXCAVATION ADJUSTED FOR SHRINKAGE (85%)					EMBANKMENT					EARTHWORK BALANCE WASTE					
			(FT)	(CUBIC YARDS)	(CUBIC YARDS)	(CUBIC YARDS)	(CUBIC YARDS)	(CUBIC YARDS)	(CUBIC YARDS)	(CUBIC YARDS)	(CUBIC YARDS)	(CUBIC YARDS)	(CUBIC YARDS)	(CUBIC YARDS)	(CUBIC YARDS)	(CUBIC YARDS)	(CUBIC YARDS)	(CUBIC YARDS)	(CUBIC YARDS)	(CUBIC YARDS)	(CUBIC YARDS)	(CUBIC YARDS)	
				STAGE 1	STAGE 1A	STAGE 2	STAGE 2A	STAGE 3	STAGE 1	STAGE 1A	STAGE 2	STAGE 2A	STAGE 3	STAGE 1	STAGE 1A	STAGE 2	STAGE 2A	STAGE 3	STAGE 1	STAGE 1A	STAGE 2	STAGE 2A	STAGE 3
6085+00.00	6085+50.00	50.0	25.0	0.0	0.0	0.0	0.0	22.0	0.0	0.0	0.0	0.0	27.0	0.0	0.0	0.0	0.0	-5.0	0.0	0.0	0.0	0.0	
6085+50.00	6086+00.00	50.0	50.0	0.0	0.0	0.0	0.0	43.0	0.0	0.0	0.0	0.0	21.0	0.0	0.0	0.0	0.0	22.0	0.0	0.0	0.0	0.0	
6086+00.00	6086+50.00	50.0	29.0	0.0	0.0	0.0	0.0	25.0	0.0	0.0	0.0	0.0	35.0	0.0	0.0	0.0	0.0	-10.0	0.0	0.0	0.0	0.0	
6086+50.00	6087+00.00	50.0	39.0	0.0	0.0	0.0	0.0	34.0	0.0	0.0	0.0	0.0	27.0	0.0	0.0	0.0	0.0	7.0	0.0	0.0	0.0	0.0	
6087+00.00	6087+50.00	50.0	52.0	0.0	0.0	0.0	0.0	45.0	0.0	0.0	0.0	0.0	9.0	0.0	3.0	0.0	0.0	36.0	0.0	-3.0	0.0	0.0	
6087+50.00	6088+00.00	50.0	49.0	0.0	0.0	0.0	0.0	42.0	0.0	0.0	0.0	0.0	12.0	0.0	5.0	0.0	0.0	30.0	0.0	-5.0	0.0	0.0	
6088+00.00	6088+50.00	50.0	73.0	0.0	0.0	0.0	0.0	63.0	0.0	0.0	0.0	0.0	15.0	0.0	5.0	0.0	0.0	48.0	0.0	-5.0	0.0	0.0	
6088+50.00	6089+00.00	50.0	88.0	0.0	0.0	0.0	0.0	75.0	0.0	0.0	0.0	0.0	15.0	0.0	11.0	0.0	0.0	60.0	0.0	-11.0	0.0	0.0	
6089+00.00	6089+50.00	50.0	90.0	0.0	0.0	0.0	0.0	77.0	0.0	0.0	0.0	0.0	7.0	0.0	19.0	0.0	0.0	70.0	0.0	-19.0	0.0	0.0	
6089+50.00	6090+00.00	50.0	81.0	0.0	0.0	0.0	0.0	69.0	0.0	0.0	0.0	0.0	5.0	0.0	25.0	0.0	0.0	64.0	0.0	-25.0	0.0	0.0	
6090+00.00	6090+50.00	50.0	72.0	0.0	0.0	0.0	0.0	62.0	0.0	0.0	0.0	0.0	11.0	0.0	30.0	0.0	0.0	51.0	0.0	-30.0	0.0	0.0	
6090+50.00	6091+00.00	50.0	62.0	0.0	0.0	0.0	0.0	53.0	0.0	0.0	0.0	0.0	13.0	0.0	46.0	0.0	0.0	40.0	0.0	-46.0	0.0	0.0	
6091+00.00	6091+50.00	50.0	69.0	0.0	0.0	0.0	0.0	59.0	0.0	0.0	0.0	0.0	17.0	0.0	76.0	0.0	0.0	42.0	0.0	-76.0	0.0	0.0	
6091+50.00	6092+00.00	50.0	91.0	0.0	0.0	0.0	0.0	78.0	0.0	0.0	0.0	0.0	16.0	0.0	54.0	0.0	0.0	62.0	0.0	-54.0	0.0	0.0	
6092+00.00	6092+50.00	50.0	108.0	0.0	0.0	0.0	0.0	92.0	0.0	0.0	0.0	0.0	12.0	0.0	18.0	0.0	0.0	80.0	0.0	-18.0	0.0	0.0	
6092+50.00	6093+00.00	50.0	120.0	0.0	0.0	0.0	0.0	102.0	0.0	0.0	0.0	0.0	33.0	0.0	12.0	0.0	0.0	69.0	0.0	-12.0	0.0	0.0	
6093+00.00	6093+50.00	50.0	114.0	0.0	0.0	0.0	0.0	97.0	0.0	0.0	0.0	0.0	57.0	0.0	0.0	0.0	0.0	40.0	0.0	0.0	0.0	0.0	
6093+50.00	6094+00.00	50.0	113.0	0.0	0.0	0.0	0.0	97.0	0.0	0.0	0.0	0.0	65.0	0.0	0.0	0.0	0.0	32.0	0.0	0.0	0.0	0.0	
6094+00.00	6094+50.00	50.0	168.0	0.0	0.0	0.0	0.0	143.0	0.0	0.0	0.0	0.0	65.0	0.0	0.0	0.0	0.0	78.0	0.0	0.0	0.0	0.0	
6094+50.00	6095+00.00	50.0	200.0	0.0	0.0	0.0	0.0	170.0	0.0	0.0	0.0	0.0	106.0	0.0	0.0	0.0	0.0	64.0	0.0	0.0	0.0	0.0	
6095+00.00	6095+50.00	50.0	259.0	0.0	0.0	0.0	0.0	221.0	0.0	0.0	0.0	0.0	133.0	0.0	0.0	0.0	0.0	88.0	0.0	0.0	0.0	0.0	
6095+50.00	6096+00.00	50.0	322.0	0.0	0.0	0.0	0.0	274.0	0.0	0.0	0.0	0.0	108.0	0.0	0.0	0.0	0.0	166.0	0.0	0.0	0.0	0.0	
6096+00.00	6096+50.00	50.0	305.0	0.0	0.0	0.0	0.0	260.0	0.0	0.0	0.0	0.0	101.0	0.0	0.0	0.0	0.0	159.0	0.0	0.0	0.0	0.0	
6096+50.00	6097+00.00	50.0	292.0	0.0	0.0	0.0	0.0	249.0	0.0	0.0	0.0	0.0	102.0	0.0	0.0	0.0	0.0	147.0	0.0	0.0	0.0	0.0	
6097+00.00	6097+50.00	50.0	288.0	0.0	0.0	0.0	0.0	245.0	0.0	0.0	0.0	0.0	105.0	0.0	0.0	0.0	0.0	140.0	0.0	0.0	0.0	0.0	
6097+50.00	6098+00.00	50.0	575.0	0.0	0.0	0.0	0.0	499.0	0.0	0.0	0.0	0.0	93.0	0.0	0.0	0.0	0.0	396.0	0.0	0.0	0.0	0.0	
<b>SUBTOTAL</b>			5579.0	0.0	0.0	0.0	0.0	4773.0	0.0	0.0	0.0	0.0	6144.0	0.0	304.0	0.0	0.0	-1371.0	0.0	-304.0	0.0	0.0	
<b>US 52 RAMP D</b>																							
200+67.73	201+00.00	32.3	0.0	0.0	35.0	18.0	0.0	0.0	0.0	30.0	16.0	0.0	0.0	0.0	0.0	0.0	0.0	0.0	0.0	30.0	16.0	0.0	
201+00.00	201+50.00	50.0	0.0	0.0	55.0	25.0	0.0	0.0	0.0	47.0	22.0	0.0	0.0	0.0	0.0	0.0	0.0	0.0	0.0	26.0	22.0	0.0	
201+50.00	202+00.00	50.0	0.0	0.0	66.0	18.0	0.0	0.0	0.0	57.0	16.0	0.0	0.0	0.0	43.0	0.0	0.0	0.0	0.0	14.0	16.0	0.0	
202+00.00	202+50.00	50.0	0.0	0.0	64.0	12.0	0.0	0.0	0.0	55.0	11.0	0.0	0.0	0.0	36.0	0.0	0.0	0.0	0.0	19.0	11.0	0.0	
202+50.00	203+00.00	50.0	0.0	0.0	115.0	9.0	0.0	0.0	0.0	98.0	8.0	0.0	0.0	0.0	13.0	0.0	0.0	0.0	0.0	85.0	8.0	0.0	
203+00.00	203+50.00	50.0	0.0	0.0	155.0	8.0	0.0	0.0	0.0	132.0	7.0	0.0	0.0	0.0	0.0	0.0	0.0	0.0	0.0	132.0	7.0	0.0	
203+50.00	204+00.00	50.0	0.0	0.0	112.0	8.0	0.0	0.0	0.0	96.0	7.0	0.0	0.0	0.0	0.0	0.0	0.0	0.0	0.0	96.0	7.0	0.0	
204+00.00	204+50.00	50.0	0.0	0.0	118.0	8.0	0.0	0.0	0.0	101.0	7.0	0.0	0.0	0.0	35.0	0.0	0.0	0.0	0.0	66.0	7.0	0.0	
204+50.00	205+00.00	50.0	0.0	0.0	131.0	7.0	0.0	0.0	0.0	112.0	6.0	0.0	0.0	0.0	148.0	0.0	0.0	0.0	0.0	-36.0	6.0	0.0	
205+00.00	205+50.00	50.0	0.0	0.0	86.0	6.0	0.0	0.0	0.0	74.0	6.0	0.0	0.0	0.0	187.0	0.0	0.0	0.0	0.0	-113.0	6.0	0.0	
205+50.00	206+00.00	50.0	0.0	0.0	53.0	3.0	0.0	0.0	0.0	46.0	3.0	0.0	0.0	0.0	99.0	0.0	0.0	0.0	0.0	-53.0	3.0	0.0	
206+00.00	206+50.00	50.0	0.0	0.0	76.0	0.0	0.0	0.0	0.0	65.0	0.0	0.0	0.0	0.0	32.0	0.0	0.0	0.0	0.0	33.0	0.0	0.0	
206+50.00	207+00.00	50.0	0.0	0.0	100.0	0.0	0.0	0.0	0.0	85.0	0.0	0.0	0.0	0.0	33.0	0.0	0.0	0.0	0.0	52.0	0.0	0.0	
207+00.00	207+50.00	50.0	0.0	0.0	92.0	0.0	0.0	0.0	0.0	79.0	0.0	0.0	0.0	0.0	52.0	0.0	0.0	0.0	0.0	27.0	0.0	0.0	
207+50.00	208+00.00	50.0	0.0	0.0	65.0	0.0	0.0	0.0	0.0	56.0	0.0	0.0	0.0	0.0	57.0	0.0	0.0	0.0	0.0	-1.0	0.0	0.0	
208+00.00	208+50.00	50.0	0.0	0.0	80.0	0.0	0.0	0.0	0.0	68.0	0.0	0.0	0.0	0.0	68.0	0.0	0.0	0.0	0.0	0.0	0.0	0.0	
208+50.00	209+00.00	50.0	0.0	0.0	89.0	0.0	0.0	0.0	0.0	76.0	0.0	0.0	0.0	0.0	65.0	0.0	0.0	0.0	0.0	11.0	0.0	0.0	
<b>SUBTOTAL</b>			0.0	0.0	1492.0	122.0	0.0	0.0	0.0	1277.0	109.0	0.0	0.0	0.0	889.0	0.0	0.0	0.0	0.0	388.0	109.0	0.0	

MODEL Default E:\MapInfo\Benesch\proj\benesch-us-52ramp.dwg Phase 1\General\15-PhaseSchedule-14.dwg  
 D:\162H15-sh1-schedule-14.dwg  
 50 107  
 2012\11\30



USER NAME	= nReynolds
PLOT SCALE	= 24,0000 * / ft.
PLOT DATE	= 2/7/2022

DESIGNED	-
DRAWN	-
CHECKED	-
DATE	- 02/04/2022

REVISED	-
REVISED	-
REVISED	-
REVISED	-

### STATE OF ILLINOIS DEPARTMENT OF TRANSPORTATION

<b>SCHEDULE OF QUANTITIES</b>			
<b>EARTHWORK</b>			
SCALE: NO SCALE	SHEET	OF SHEETS	STA. TO STA.

F.A./P.RTE.	SECTION	COUNTY	TOTAL SHEETS	SHEET NO.
	2018-075-R	WILL	1510	78
CONTRACT NO. 62H15			FAI 55, FAP 338 ILLINOIS FED. AID PROJECT	

**EARTHWORK SCHEDULE OF QUANTITIES**

STATION TO STATION	LENGTH (FT)	EARTH EXCAVATION					EARTH EXCAVATION ADJUSTED FOR SHRINKAGE (85%)					EMBANKMENT					EARTHWORK BALANCE WASTE				
	(FT)	(CUBIC YARDS)	(CUBIC YARDS)	(CUBIC YARDS)	(CUBIC YARDS)	(CUBIC YARDS)	(CUBIC YARDS)	(CUBIC YARDS)	(CUBIC YARDS)	(CUBIC YARDS)	(CUBIC YARDS)	(CUBIC YARDS)	(CUBIC YARDS)	(CUBIC YARDS)	(CUBIC YARDS)	(CUBIC YARDS)	(CUBIC YARDS)	(CUBIC YARDS)	(CUBIC YARDS)	(CUBIC YARDS)	
		STAGE 1	STAGE 1A	STAGE 2	STAGE 2A	STAGE 3	STAGE 1	STAGE 1A	STAGE 2	STAGE 2A	STAGE 3	STAGE 1	STAGE 1A	STAGE 2	STAGE 2A	STAGE 3	STAGE 1	STAGE 1A	STAGE 2	STAGE 2A	STAGE 3
<b>TOTAL</b>		114,608.00	2,533.00	17,988.00	15,527.00	1,368.00	97,553.00	2,170.00	15,394.00	13,251.00	1,181.00	171,260.00	2,928.00	134,150.00	105,179.00	446.00	(73,707.00)	(758.00)	(118,756.00)	(91,928.00)	735.00

PAY ITEM	UNIT	IDOT QUANTITY	JOLIET QUANTITY	TOTAL QUANTITY	TOPSOIL PLACEMENT	TOPSOIL SURPLUS
EARTH EXCAVATION	CU YD	141,734.00	10,290.00	152,024.00	-	-
FURNISHED EXCAVATION	CU YD	174,310.00	110,104.00	284,414.00	-	-
TOPSOIL EXCAVATION AND PLACEMENT	CU YD	87,712.00	18,302.00	106,014.00	80,342.00	25,672.00
REMOVAL AND DISPOSAL OF UNSUITABLE MATERIAL	CU YD	34,325.00	3,625.00	37,950.00	-	-
AGGREGATE SUBGRADE IMPROVEMENT	CU YD	34,325.00	3,625.00	37,950.00	-	-
GEOTECHNICAL FABRIC FOR GROUND STABILIZATION	SQ YD	45,990.00	8,262.00	54,252.00	-	-

TOPSOIL NOTES:

- ALL TOPSOIL RELATED WORK WILL BE PAID FOR BY THE CUBIC YARD USING THE PAY ITEM: "TOPSOIL EXCAVATION AND PLACEMENT". THE QUANTITY MEASURED FOR PAYMENT IS BASED ON THE EXCAVATED TOPSOIL, NOT THE PLACED TOPSOIL.
- TOPSOIL SPOIL PILE LOCATIONS WITHIN THE IDOT RIGHT-OF-WAY HAVE BEEN IDENTIFIED IN THE PLANS.
- ALL SOIL BORINGS IDENTIFYING THE PRESENCE OF TOPSOIL HAVE BEEN LISTED ON THE ASSUMED EXISTING TOPSOIL THICKNESS PLANS. THE VOLUME OF AVAILABLE EXISTING TOPSOIL IS ESTIMATED AT 106,014 CUBIC YARDS. THIS QUANTITY INCLUDES THE 6,366 CUBIC YARD EXISTING TOPSOIL STOCK PILE CONSTRUCTED IN IDOT CONTRACT 62M63.
- ALL LANDSCAPE AREAS SHOWN TO RECEIVE TOPSOIL PLACEMENT MUST HAVE A MINIMUM 4" THICKNESS TO PROMOTE VEGETATION GROWTH. THE PROPOSED TOPSOIL PLANS INCLUDE ADDITIONAL AREAS WHERE 12" THICKNESS AND 30" THICKNESS IS SPECIFIED. THESE THICKNESS WERE IDENTIFIED IN ORDER TO UTILIZE AS MUCH EXISTING TOPSOIL AS POSSIBLE. THE TOTAL VOLUME OF TOPSOIL PLACEMENT IS ESTIMATED AT 80,342 CUBIC YARDS.
- THE PROJECT HAS AN ESTIMATED SURPLUS OF 25,672 CUBIC YARDS (106,014 - 80,342) OF TOPSOIL. THE CONTRACTOR IS RESPONSIBLE FOR HAULING AND DISPOSAL OF THE SURPLUS TOPSOIL OFF THE THE PROJECT SITE. NO ADDITIONAL COMPENSATION WILL BE ALLOWED FOR HAULING AND DISPOSAL OF SURPLUS TOPSOIL.
- IT IS THE RESPONSIBILITY OF THE CONTRACTOR TO MAINTAIN ACCURATE RECORDS OF TOPSOIL EXCAVATION QUANTITY AS THE TOPSOIL IS STRIPPED. THE CONTRACTOR SHALL NOTE THE TOTAL VOLUME OF EXCAVATED TOPSOIL PLACED IN THE SPOIL PILES. IN THE EVENT THAT THE CONTRACTOR CALCULATES THAT THERE WILL BE INSUFFICIENT TOPSOIL VOLUME AVAILABLE TO MEET THE PROPOSED PLACEMENT DEPTHS, THE CONTRACTOR SHALL NOTIFY THE ENGINEER IMMEDIATELY. A PROPOSED ACTION PLAN MUST BE IMPLEMENTED TO REDUCE THE THICKNESS OF THE 30" PLACEMENT AREAS IN AN ATTEMPT TO BALANCE THE PROJECT TOPSOIL. THE 30" PLACEMENT AREAS CAN BE REDUCED TO 4" MINIMUM IF REQUIRED. IF THE ABOVE ACTION RESULTS IN A CONTINUED SHORTAGE OF AVAILABLE TOPSOIL, ONE OR MORE AREAS OF 12" PLACEMENT CAN BE REDUCED TO A MINIMUM OF 4".
- ALL COSTS ASSOCIATED WITH CALCULATING THE AMOUNT OF AVAILABLE TOPSOIL VERSUS THE AMOUNT OF TOPSOIL REQUIRED TO MEET PLAN AND ANY ACTION PLANS CREATED WILL NOT BE MEASURED FOR PAVEMENT AND ARE CONSIDERED INCLUDED IN THE PAY ITEM: "TOPSOIL EXCAVATION AND PLACEMENT".

UNDERCUTTING NOTES:

- IN ADDITION TO THE UNDERCUTTING TABLE ON THIS SHEET, THE FOLLOWING QUANTITIES HAVE BEEN PROVIDED IN THE CONTRACT FOR USE AS DETERMINED BY THE ENGINEER IF POOR/SOFT SOILS ARE IDENTIFIED DURING CONSTRUCTION:

REMOVAL AND DISPOSAL OF UNSUITABLE MATERIAL: 11,000 CUBIC YARDS  
 AGGREGATE SUBGRADE IMPROVEMENT: 11,000 CUBIC YARDS  
 GEOTECHNICAL FABRIC FOR GROUND STABILIZATION: 30,000 SQUARE YARDS

THE ABOVE MATERIAL SHALL BE USED TO REPLACE ANY UNSUITABLE SOILS BELOW THE BOTTOM OF AGGREGATE BASECOURSE LAYER THAT ARE ENCOUNTERED IN THE FIELD DURING CONSTRUCTION. THE ACTUAL NEED FOR REMOVAL AND REPLACEMENT WITH AGGREGATE SUBGRADE IMPROVEMENT SHALL BE DETERMINED IN THE FIELD AT THE TIME OF CONSTRUCTION BY THE GEOTECHNICAL ENGINEER OR SOILS INSPECTOR. ALL POTENTIALLY UNSTABLE SOILS SHOULD BE TESTED WITH A CONE PENETROMETER AND TREATED IN ACCORDANCE WITH ARTICLE 301.04 OF THE SSRBC AND THE UNDERCUT GUIDELINES IN THE IDOT SUBGRADE STABILITY MANUAL. ANY MATERIAL NOT NEEDED FOR UNDERCUT REPLACEMENT AT THE TIME OF CONSTRUCTION SHOULD BE DELETED FROM THE CONTRACT WITH NO EXTRA COMPENSATION TO THE CONTRACTOR.

GEOTEXTILE FABRIC SHALL BE PLACED AT THE BASE OF UNDERCUT AREAS WHERE LOW STRENGTH SUBGRADE SOILS ARE ENCOUNTERED. FABRIC SHALL MEET THE REQUIREMENTS OF ARTICLE 210, FABRIC FOR GROUND STABILIZATION, OF THE SSRBS. ANY MATERIAL NOT NEEDED AT THE TIME OF CONSTRUCTION SHALL BE DELETED FROM THE CONTRACT WITH NO EXTRA COMPENSATION TO THE CONTRACTOR.

MODEL: Default; FILE: \\benedsch-pw-bentley.com\benesch-pw\1\Documents\1\0705\10740\_00\Eng\_Docs\_Phase\_1\General\162H15-shi-schedule-15.dgn



USER NAME = nReynolds	DESIGNED -	REVISED -
PLOT SCALE = 24,0000 * / ft.	CHECKED -	REVISED -
PLOT DATE = 2/7/2022	DATE - 02/04/2022	REVISED -

**STATE OF ILLINOIS  
DEPARTMENT OF TRANSPORTATION**

**SCHEDULE OF QUANTITIES  
EARTHWORK**

SCALE: NO SCALE SHEET OF SHEETS STA. TO STA.

F.A./P RTE.	SECTION	COUNTY	TOTAL SHEETS	SHEET NO.
*	2018-075-R	WILL	1510	79
CONTRACT NO. 62H15				
* FAI 55, FAP 338 ILLINOIS FED. AID PROJECT				

TREE REMOVAL (6 TO 15 UNITS)		
STATION	OFFSET	QUANTITY (UNIT)
<b>EX I-55</b>		
276+15.35	142.5' LT	--
276+33.94	140.2' LT	--
276+56.14	148.7' LT	--
276+77.66	149.4' LT	--
277+76.03	156.4' LT	--
277+92.92	165.7' LT	--
282+77.24	80.6' RT	--
283+15.41	117.7' RT	7
283+18.82	111.9' RT	--
283+30.73	91.3' RT	--
283+77.14	116.9' RT	12
283+94.15	111.6' RT	12
284+03.75	81.5' RT	--
284+06.04	145.8' RT	--
284+21.91	86.9' RT	--
284+27.70	95.2' RT	8
284+37.91	99.2' RT	10
284+45.85	143.8' RT	6
284+62.00	97.7' RT	24
284+75.83	88.8' RT	11
284+79.73	178.5' RT	--
284+98.71	180.8' RT	6
285+02.14	98.1' RT	14
285+03.25	98.8' RT	7
285+04.75	154.5' RT	6
285+33.24	137.1' RT	--
285+44.39	156.0' RT	--
285+65.16	92.7' RT	12
285+71.19	163.2' RT	--
285+72.45	189.7' RT	--
285+73.96	95.1' RT	--
285+74.81	99.6' RT	--
285+80.24	213.3' RT	--
285+82.30	105.3' RT	9
285+82.52	192.7' RT	10
285+86.55	186.7' RT	--
285+90.85	102.9' RT	7
285+93.52	145.7' RT	30
285+94.69	114.0' RT	--
285+95.78	186.1' RT	--
285+97.29	215.5' RT	60
285+98.13	213.7' RT	18
286+03.54	205.5' RT	--
286+07.14	93.2' RT	7
286+08.19	195.3' RT	6
286+14.26	195.3' RT	--
286+14.62	126.7' RT	--
286+17.00	205.5' RT	--
286+19.69	197.5' RT	7
286+21.32	254.7' RT	--
286+21.44	254.9' RT	--
286+21.83	234.0' RT	--
286+23.98	129.0' RT	--
286+27.73	255.2' RT	--
286+28.01	153.3' RT	9
286+28.12	254.4' RT	--
286+31.49	146.3' RT	--
286+33.69	241.3' RT	--
286+33.86	189.4' RT	--
286+35.31	143.5' RT	6
286+40.06	188.9' RT	--
286+40.27	131.1' RT	--
286+43.12	190.7' RT	--
286+49.40	196.2' RT	--
286+53.64	206.3' RT	--

TREE REMOVAL (6 TO 15 UNITS)		
STATION	OFFSET	QUANTITY (UNIT)
<b>EX I-55</b>		
286+61.02	203.3' RT	--
286+64.73	269.8' RT	--
286+65.49	151.4' RT	--
286+65.63	109.6' RT	--
286+66.70	118.9' RT	--
286+69.11	247.6' RT	--
286+71.06	237.1' RT	--
286+78.00	240.8' RT	--
286+78.03	129.4' RT	27
286+92.42	197.5' RT	7
286+92.83	245.6' RT	8
286+98.00	171.6' RT	--
286+99.41	165.6' RT	--
287+03.57	164.9' RT	--
287+04.61	238.0' RT	7
287+07.83	171.2' RT	--
287+08.65	77.6' RT	--
287+22.43	207.5' RT	9
287+22.78	76.9' RT	--
287+22.91	88.8' RT	--
287+23.36	235.0' RT	--
287+25.67	271.3' RT	--
287+28.60	77.3' RT	--
287+31.15	261.9' RT	--
287+33.91	219.0' RT	--
287+34.17	125.4' RT	--
287+37.32	290.4' RT	--
287+37.85	77.5' RT	--
287+38.29	264.8' RT	--
287+40.02	276.6' RT	--
287+42.48	264.8' RT	6
287+43.76	77.7' RT	--
287+44.38	291.2' RT	--
287+50.14	288.9' RT	--
287+50.23	263.4' RT	--
287+52.18	126.8' RT	--
287+68.59	258.8' RT	6
287+69.72	293.2' RT	14
287+73.77	154.5' RT	--
287+74.03	175.5' RT	--
287+75.45	99.0' RT	--
287+76.85	238.9' RT	7
287+78.57	287.9' RT	--
287+80.72	304.1' RT	--
287+86.19	294.4' RT	--
287+90.00	304.6' RT	--
287+93.17	294.8' RT	--
287+93.40	253.6' RT	--
287+93.74	302.9' RT	--
287+95.37	101.4' LT	--
287+97.86	213.7' RT	--
288+01.56	307.3' RT	--
288+04.79	140.8' RT	14
288+05.76	105.2' LT	--
288+07.70	273.5' RT	--
288+08.39	267.3' RT	--
288+10.42	309.1' RT	--
288+11.40	262.3' RT	--
288+14.22	106.0' LT	--
288+16.38	261.8' RT	--
288+17.27	254.9' RT	--
288+20.58	166.6' RT	--
288+21.86	285.8' RT	--
288+24.29	297.2' RT	--
288+26.20	277.9' RT	--

TREE REMOVAL (6 TO 15 UNITS)		
STATION	OFFSET	QUANTITY (UNIT)
<b>EX I-55</b>		
288+26.39	166.8' RT	10
288+27.33	79.7' RT	--
288+30.28	302.2' RT	--
288+31.09	313.3' RT	--
288+33.28	313.2' RT	--
288+33.45	120.3' RT	--
288+34.08	290.0' RT	--
288+39.78	240.8' RT	--
288+43.82	299.6' RT	--
288+46.50	292.3' RT	--
288+51.32	287.6' RT	--
288+51.46	292.7' RT	--
288+54.48	303.4' RT	--
288+59.76	88.4' LT	14
288+73.53	251.1' RT	--
288+92.93	290.5' RT	8
288+97.53	146.7' RT	9
288+99.43	140.7' RT	--
289+00.12	268.6' RT	--
289+00.43	187.6' RT	--
289+06.83	213.8' RT	--
289+07.75	216.9' RT	--
289+10.28	227.1' RT	--
289+14.46	261.2' RT	12
289+20.68	219.6' RT	7
289+21.55	92.1' RT	--
289+29.50	319.8' RT	--
289+31.10	298.1' RT	8
289+34.57	171.2' RT	--
289+37.93	298.5' RT	12
289+43.37	148.1' RT	--
289+44.20	107.6' LT	--
289+51.89	231.9' RT	--
289+58.49	106.8' LT	16
289+61.23	104.7' LT	6
289+76.38	107.1' RT	--
289+81.49	229.5' RT	11
289+94.13	270.6' RT	48
290+00.82	196.6' RT	--
290+20.12	107.0' RT	--
290+24.55	307.6' RT	--
290+26.88	214.1' RT	--
290+27.74	307.1' RT	--
290+27.94	92.1' LT	--
290+29.38	306.1' RT	--
290+66.82	70.0' RT	--
290+71.18	70.2' RT	--
290+73.92	72.3' RT	--
290+80.08	71.9' RT	--
291+02.45	68.2' RT	--
291+05.14	70.9' RT	--
291+16.33	79.9' LT	--
291+22.65	119.5' RT	--
291+24.80	89.0' LT	--
291+29.83	102.6' LT	10
291+30.34	100.6' LT	10
291+36.59	141.4' RT	96
291+37.57	104.5' LT	--
291+39.06	106.2' RT	--
291+55.23	276.6' RT	--
291+64.22	133.3' RT	30
292+00.40	84.5' LT	10
292+03.15	87.2' LT	12
292+04.67	87.0' LT	6
292+05.89	82.5' LT	10

TREE REMOVAL (6 TO 15 UNITS)		
STATION	OFFSET	QUANTITY (UNIT)
<b>EX I-55</b>		
292+07.12	84.3' LT	6
292+08.59	81.7' LT	8
292+15.08	146.6' RT	--
292+15.47	81.7' RT	7
292+16.37	84.6' LT	8
292+22.59	90.9' LT	12
292+23.29	97.5' LT	8
292+25.45	117.0' RT	--
292+26.38	210.1' RT	56
292+28.52	93.9' LT	6
292+29.02	150.4' RT	--
292+29.27	158.9' RT	--
292+31.43	78.4' RT	--
292+31.85	154.0' RT	--
292+34.80	83.7' LT	8
292+35.30	86.9' LT	8
292+37.98	100.1' LT	12
292+45.13	89.4' LT	6
292+47.06	87.5' LT	9
292+47.18	83.0' LT	8
292+48.06	84.8' LT	8
292+48.36	88.0' LT	9
292+49.26	89.8' LT	9
292+51.17	89.8' LT	9
292+52.69	85.8' LT	9
292+53.37	90.6' LT	12
292+53.70	129.9' RT	--
292+54.42	214.6' RT	24
292+54.82	187.1' RT	7
292+55.51	215.1' RT	7
292+56.89	215.0' RT	12
292+58.86	195.8' RT	--
292+61.40	76.2' LT	12
292+65.47	238.2' RT	9
292+66.72	102.2' RT	--
292+77.75	199.2' RT	--
292+80.25	88.9' LT	8
292+80.85	83.7' LT	10
292+83.72	106.0' RT	13
292+85.89	165.3' RT	6
292+88.77	216.6' RT	10
292+90.62	163.7' RT	18
292+95.06	101.2' LT	9
293+10.95	215.2' RT	12
293+13.61	77.2' RT	--
293+15.28	146.5' RT	6
293+17.24	148.3' RT	6
293+19.71	137.0' LT	--
293+20.15	106.1' LT	--
293+21.04	214.7' RT	--
293+31.91	179.7' RT	12
293+34.22	104.8' LT	--
293+38.79	192.9' RT	15
293+39.77	186.4' RT	14
293+46.15	177.7' RT	11
293+48.34	143.2' RT	--
293+49.90	98.9' LT	12
293+57.43	163.9' RT	12
293+61.53	157.3' RT	12
293+68.43	130.3' RT	10
293+74.94	161.6' RT	9
293+89.03	98.5' RT	7
293+91.49	138.6' RT	8
293+98.39	134.6' RT	12
294+01.62	119.0' RT	10

TREE REMOVAL (6 TO 15 UNITS)		
STATION	OFFSET	QUANTITY (UNIT)
<b>EX I-55</b>		
294+18.62	113.6' RT	12
294+22.14	80.6' LT	10
294+24.23	117.5' RT	8
294+27.82	116.7' RT	12
294+31.91	115.5' RT	12
294+36.22	76.9' LT	8
294+37.15	76.9' LT	16
294+37.19	81.6' LT	8
294+37.42	79.8' LT	8
294+39.23	77.9' LT	16
294+43.03	78.4' LT	9
294+64.98	124.5' LT	13
294+72.71	91.0' LT	--
294+75.80	82.5' LT	--
294+77.57	82.8' LT	--
295+33.77	105.1' LT	--
297+87.74	106.6' LT	18
297+90.54	112.0' RT	--
297+97.91	120.0' LT	14
297+98.89	123.1' LT	14
298+08.65	120.0' LT	12
298+13.83	124.5' LT	6
298+28.29	138.3' LT	12
298+34.17	121.0' LT	7
298+36.39	121.6' LT	7
298+45.08	136.7' LT	--
298+51.34	127.7' LT	6
298+54.85	135.0' LT	6
298+61.48	125.3' LT	6
298+71.91	116.3' LT	10
298+76.56	135.4' LT	12
298+87.56	91.3' RT	13
298+99.44	106.5' LT	6
299+14.82	111.8' LT	6
299+19.61	108.4' LT	8
299+20.43	87.1' RT	--
299+24.71	105.0' LT	6
299+25.26	126.2' LT	6
299+36.62	135.0' LT	11
299+51.35	139.9' LT	12
299+53.48	106.4' LT	10
299+57.38	126.3' LT	12
299+62.68	88.8' LT	6
299+63.12	88.0' RT	14
299+64.28	118.0' LT	6
300+07.27	77.0' RT	--
300+20.42	80.4' RT	7
300+39.93	77.0' RT	14
300+53.23	93.6' RT	20
300+55.18	77.4' RT	--
301+84.09	74.1' RT	--
301+04.81	81.8' RT	--
301+27.62	142.1' LT	8
301+29.04	141.5' LT	12
301+30.67	71.7' RT	--
301+31.42	75.1' RT	--
301+31.66	73.0' RT	--
301+85.96	88.6' RT	8
301+99.96	85.7' RT	--
302+47.87	91.2' RT	12
302+70.14	76.6' RT	7
302+96.47</		



MODEL: Default  
FILE: h:\a111\_e:\pub\benef\com\benef\schedule-02.dgn  
D:\62H15\st-removal-schedule-02.dgn  
51345  
2012/11/30

TREE REMOVAL (6 TO 15 UNITS)		
STATION	OFFSET	QUANTITY (UNIT)
<b>EX SEIL RD</b>		
4001+06.05	33.8' LT	8
4002+06.59	37.7' LT	8
4002+27.62	31.0' LT	13
4002+45.14	36.3' LT	12
4002+63.19	31.7' LT	10
4002+79.57	35.5' LT	6
4002+95.92	29.5' LT	7
4003+86.45	39.1' LT	8
4003+93.90	28.7' LT	6
4004+05.46	31.2' LT	6
4004+42.03	39.8' LT	12
4004+91.38	39.2' LT	10
4005+13.94	38.6' LT	8
4005+25.06	34.5' LT	8
4005+35.95	40.2' LT	10
4005+52.51	43.3' LT	10
4005+63.27	37.7' LT	12
4005+95.22	39.4' LT	12
4006+07.02	43.5' LT	12
4006+18.62	36.8' LT	15
4006+65.25	39.6' LT	12
4006+81.91	40.5' LT	10
4006+91.76	43.7' LT	10
4007+00.60	40.5' LT	9
4007+14.94	40.3' LT	--
4007+21.03	38.0' LT	--
4007+21.32	45.0' LT	--
4007+26.52	40.2' LT	--
4007+29.67	37.6' LT	--
4007+34.82	43.9' LT	--
4007+71.45	38.0' LT	--
4007+75.59	47.1' LT	--
4007+78.42	37.7' LT	--
4007+83.56	48.1' LT	--
4007+87.44	37.3' LT	--
4007+97.50	36.1' LT	8
4008+07.00	45.5' LT	8
4008+27.94	44.8' LT	12
4008+35.84	35.0' LT	12
4008+45.20	47.0' LT	12
4008+51.40	33.8' LT	8
4008+66.35	42.4' LT	8
4008+66.55	34.5' LT	7
4008+86.75	37.7' LT	6
4008+98.04	43.5' LT	10
4009+01.15	35.0' LT	10
4009+10.80	44.2' LT	7
4009+17.58	37.6' LT	6
4009+23.76	44.8' LT	8
4009+43.61	42.2' LT	6
4009+55.36	42.6' LT	6
4013+02.73	39.0' LT	--
4013+31.14	38.8' LT	--
4013+79.45	42.6' LT	--
4014+09.69	37.7' LT	--
4014+52.80	42.8' LT	--
4015+00.52	42.4' LT	--
4015+41.86	46.8' LT	--
4016+40.83	93.4' RT	--

TREE REMOVAL (6 TO 15 UNITS)		
STATION	OFFSET	QUANTITY (UNIT)
<b>EX E FRONTAGE RD</b>		
6022+19.34	34.3' RT	--
6022+37.68	41.3' LT	12
6022+56.44	65.0' LT	18
6022+60.68	46.9' LT	--
6022+90.68	34.6' LT	--
6022+94.30	94.6' LT	12
6023+15.84	61.4' LT	--
6023+38.15	38.6' LT	--
6023+68.93	44.2' LT	--
6023+75.18	80.6' LT	12
6023+91.32	61.1' LT	10
6023+92.20	61.1' LT	10
6024+00.07	92.6' LT	--
6024+09.45	66.1' LT	10
6024+25.92	50.6' LT	--
6024+30.36	89.3' LT	--
6024+82.94	51.4' LT	8
6024+87.49	87.4' LT	8
6025+19.80	91.2' LT	7
6026+20.04	69.9' LT	7
6026+25.64	71.9' LT	--
6026+72.29	57.5' LT	--
6046+18.77	20.3' LT	--
6046+92.83	29.3' LT	12
6046+94.34	25.1' RT	--
6046+96.07	18.5' LT	15
6047+00.63	27.7' LT	--
6047+00.81	21.0' LT	9
6047+00.97	17.2' LT	6
6047+14.02	21.8' LT	6
6047+18.67	23.1' RT	--
6047+72.18	19.8' LT	8
6047+74.89	19.1' LT	6
6047+81.56	23.5' LT	12
6047+96.89	15.4' LT	6
6047+98.37	15.5' LT	14
6048+10.95	16.9' LT	12
6048+23.86	18.0' LT	6
6048+38.32	17.2' LT	6
6048+40.43	18.6' LT	12
6048+45.80	23.1' LT	8
6048+62.15	17.2' LT	10
6048+94.26	29.9' LT	18
6049+31.38	19.0' LT	8
6049+33.67	16.7' LT	6
6049+36.13	23.2' LT	--
6049+40.26	18.8' LT	--
6049+47.46	19.6' LT	--
6049+56.57	19.5' LT	--
6049+65.97	19.2' LT	--
6049+79.30	16.2' LT	--

TREE REMOVAL (6 TO 15 UNITS)		
STATION	OFFSET	QUANTITY (UNIT)
<b>EX E FRONTAGE RD</b>		
6050+01.52	19.6' LT	--
6050+03.38	15.5' LT	--
6050+25.08	18.4' LT	--
6050+41.78	27.6' LT	--
6050+42.05	20.3' LT	--
6050+45.21	27.1' LT	--
6050+45.40	22.1' LT	--
6050+50.76	16.3' LT	--
6050+54.93	16.7' LT	6
6050+58.51	24.9' LT	--
6050+60.22	16.5' LT	--
6051+15.66	42.5' LT	--
6051+46.00	40.1' LT	--
6051+57.45	44.4' LT	--
6051+57.97	26.3' LT	--
6051+67.74	21.7' LT	--
6052+20.84	15.9' LT	--
6052+40.62	22.1' LT	--
6052+41.29	25.7' LT	--
6052+51.60	26.1' LT	--
6052+57.84	16.6' LT	--
6052+81.12	20.9' LT	--
6052+89.91	21.5' LT	--
6052+97.47	21.8' LT	--
6053+24.23	20.7' LT	--
6058+29.92	13.8' LT	--
6058+69.35	28.7' LT	--
6059+13.21	45.7' LT	6
6059+61.81	28.3' LT	13
6059+95.76	59.2' LT	24
6060+16.77	58.9' LT	10
6060+29.71	53.4' LT	36
6060+34.73	52.4' LT	16
6060+83.06	40.5' LT	24
6060+88.62	15.6' LT	7
6060+92.94	47.0' LT	6
6061+02.95	94.6' LT	11
6061+08.55	98.5' LT	9
6061+12.72	22.3' LT	7
6061+15.18	83.9' LT	9
6061+27.49	55.5' LT	6
6061+30.36	37.5' LT	15
6061+33.01	37.8' LT	7
6061+45.23	19.2' LT	7
6061+48.72	60.8' LT	24
6061+50.08	24.2' LT	14
6061+67.64	54.1' LT	13
6061+67.73	20.5' LT	--
6061+76.56	17.9' LT	--
6085+23.16	332.3' LT	6
6085+23.16	283.1' LT	6

TREE REMOVAL (6 TO 15 UNITS)		
STATION	OFFSET	QUANTITY (UNIT)
<b>EX IL RTE 59 SB</b>		
7002+94.88	91.1' LT	7
7009+09.80	55.8' RT	8
7482+30.38	139.9' RT	--
7482+84.23	139.7' RT	--
7482+99.72	110.9' RT	--
7485+87.29	176.0' RT	--
7486+64.16	124.3' RT	--
7486+73.59	132.5' RT	--
7486+87.78	126.0' RT	--
7486+93.70	131.0' RT	--
7487+29.52	162.2' RT	--
7487+40.20	153.1' RT	--
7487+63.10	157.6' RT	--
7487+85.77	209.5' RT	--
7488+76.27	234.5' RT	6
7488+85.84	231.3' RT	6
7488+88.24	172.5' RT	--
7488+90.22	225.1' RT	14
7488+94.69	218.3' RT	12
7489+03.86	197.9' RT	12
7489+10.62	219.6' RT	8
7489+13.76	236.6' RT	--
7489+13.92	231.6' RT	--
7489+20.88	233.0' RT	--
7489+21.99	301.1' RT	10
7489+22.04	236.9' RT	6
7489+29.17	191.1' RT	12
7489+32.01	200.8' RT	16
7489+35.77	201.3' RT	12
7489+42.15	192.9' RT	12
7489+45.95	289.5' RT	6
7489+63.35	203.5' RT	8
7489+69.25	180.0' RT	12
7489+70.01	318.8' RT	10
7489+72.40	195.0' RT	10
7489+72.87	201.4' RT	12
7489+80.42	298.6' RT	12
7489+83.86	332.9' RT	12
7489+86.27	200.7' RT	6
7489+93.14	173.8' RT	8
7489+95.45	302.8' RT	10
7490+00.58	268.6' RT	--
7490+04.35	326.4' RT	6
7490+04.66	204.5' RT	10
7490+06.29	165.9' RT	6
7490+07.21	170.8' RT	6
7490+08.62	339.7' RT	--
7490+09.75	173.4' RT	15
7490+11.56	197.6' RT	10
7490+15.40	161.7' RT	6
7490+19.77	294.3' RT	6
7490+20.56	166.5' RT	6
7490+22.45	166.1' RT	6

TREE REMOVAL (6 TO 15 UNITS)		
STATION	OFFSET	QUANTITY (UNIT)
<b>EX IL RTE 59 SB</b>		
7490+25.69	161.5' RT	8
7490+26.77	192.4' RT	8
7490+27.59	320.8' RT	--
7490+32.85	192.4' RT	8
7490+38.83	287.9' RT	8
7490+41.59	155.8' RT	6
7490+44.75	247.9' RT	6
7490+49.28	160.9' RT	6
7490+52.84	152.5' RT	6
7490+54.14	170.5' RT	10
7490+54.64	273.1' RT	--
7490+55.06	154.1' RT	6
7490+55.12	154.9' RT	6
7490+58.74	149.4' RT	8
7490+60.27	153.0' RT	8
7490+62.08	153.8' RT	6
7490+65.45	244.0' RT	6
7490+69.34	256.6' RT	6
7490+70.14	163.4' RT	10
7490+73.39	153.3' RT	10
7490+79.54	143.2' RT	6
7490+82.02	165.1' RT	10
7490+82.58	144.0' RT	6
7490+83.90	143.4' RT	6
7490+83.90	158.0' RT	6
7490+92.24	155.2' RT	6
7490+92.37	137.2' RT	8
7491+02.10	232.4' RT	6
7491+03.09	158.4' RT	6
7491+10.14	235.1' RT	12
7491+12.98	139.9' RT	6
7491+16.27	143.8' RT	8
7491+23.13	129.5' RT	--
7491+23.41	140.9' RT	8
7491+34.53	142.8' RT	8
7491+43.72	135.3' RT	6
7491+52.91	214.5' RT	12
7491+60.09	122.6' RT	6
7491+63.73	135.7' RT	12
7491+68.01	208.8' RT	12
7491+74.42	122.1' RT	8
7491+75.73	120.4' RT	7
7491+77.70	128.1' RT	10
7491+78.22	211.8' RT	48
7491+86.60	116.4' RT	6
7491+88.78	104.8' RT	10
7491+94.12	108.2' RT	8
7492+00.46	189.6' RT	6
7492+17.39	195.7' RT	--
7492+20.65	97.4' RT	8
7492+26.20	179.9' RT	6
7492+27.62	184.8' RT	6
7492+71.96	155.2' RT	45
7493+02.59	144.4' RT	8
<b>PROJECT TOTAL</b>		<b>4,273</b>

TREE REMOVAL (OVER 15 UNITS)		
STATION	OFFSET	QUANTITY (UNIT)
<b>EX I-55</b>		
283+90.30	117.2' RT	19
284+76.44	151.6' RT	28
286+14.19	151.6' RT	18
287+89.01	95.1' LT	16
288+30.61	279.7' RT	40
288+78.54	290.5' RT	16
289+02.57	94.4' RT	30
289+52.65	291.9' RT	27
289+58.52	181.4' RT	19
289+78.31	200.6' RT	18
289+95.35	275.6' RT	24
290+63.03	257.5' RT	31
291+13.46	122.7' RT	30
292+59.86	99.1' RT	21
292+61.57	108.3' RT	32
292+78.01	119.9' RT	18
292+83.69	162.5' RT	21
292+87.61	134.0' LT	21
292+91.45	113.8' RT	26
293+13.74	222.0' RT	20
293+61.37	167.9' RT	16
293+63.42	162.8' RT	16
293+72.95	132.6' RT	27
294+20.69	90.5' RT	24
294+95.62	107.4' LT	24
295+55.75	88.6' LT	24
297+45.90	102.2' RT	23
297+62.91	88.3' LT	22
297+84.38	90.9' LT	24
298+12.34	123.1' RT	18
298+41.24	97.9' RT	31
298+75.35	98.2' LT	24
300+07.66	90.2' RT	22
301+60.80	92.5' RT	24
302+31.39	87.8' RT	19
302+82.51	92.7' RT	18
317+44.94	92.4' RT	17
319+54.83	76.5' RT	16
319+87.25	94.6' RT	16
<b>EX E FRONTAGE RD</b>		
6046+14.28	19.6' LT	16
6047+16.36	17.4' LT	24
6047+27.41	19.0' LT	24
6059+97.00	12.9' LT	17
6060+47.84	49.4' LT	30
6061+26.08	38.4' LT	17
6061+57.55	65.0' LT	28
<b>EX IL RTE 59 SB</b>		
7489+19.28	208.4' RT	16
7489+44.60	213.0' RT	18
7489+7		



PAVED SHOULDER REMOVAL				
STATION	OFFSET	STATION	OFFSET	QUANTITY (SQ YD)
<b>EX I-55</b>				
218+44.00	.7' LT	218+96.00	.7' LT	38.2
218+44.00	1.0' RT	218+96.00	1.7' RT	33.9
233+64.00	1.6' LT	234+16.00	1.6' LT	34.3
233+64.00	1.6' RT	234+16.00	1.6' RT	35.2
248+37.00	2.1' LT	248+89.00	1.8' LT	32.8
248+37.00	2.3' RT	248+89.00	1.9' RT	30.6
276+21.78	44.4' RT	330+09.97	55.9' RT	6,853.9
283+00.00	44.3' LT	337+00.87	88.6' LT	6,289.7
290+14.00	2.5' LT	290+66.00	2.7' LT	30.3
290+14.00	1.8' RT	290+66.00	1.7' RT	34.0
314+54.00	1.8' LT	315+06.00	1.7' LT	33.9
314+54.00	1.5' RT	315+06.00	1.5' RT	34.4
334+78.51	44.1' LT	337+23.89	44.1' LT	234.5
355+24.00	1.9' LT	355+76.00	1.6' LT	36.7
355+24.00	1.6' RT	355+76.00	1.6' RT	37.5
375+74.00	1.5' LT	376+26.00	1.5' LT	35.6
375+74.00	1.5' RT	376+26.00	1.5' RT	32.3
<b>EX SEIL RD</b>				
4012+39.72	21.9' RT	4014+06.99	22.2' RT	69.7
4015+38.01	22.2' RT	4017+98.40	61.3' RT	121.7
<b>EX IL RTE 59 SB</b>				
7000+71.22	17.8' RT	7021+28.04	.9' LT	1,561.4
7005+05.42	19.9' LT	7021+27.71	17.0' LT	742.6
<b>EX IL RTE 59</b>				
7475+51.99	266.4' LT	7479+85.43	37.5' LT	229.2
7476+06.93	40.0' RT	7479+63.60	39.8' RT	134.0
<b>EX IL RTE 59 NB</b>				
8000+00.00	1.2' RT	8019+11.54	1.2' RT	1,426.2
8000+56.01	15.1' LT	8019+05.50	15.1' LT	1,930.5
8022+99.54	15.2' LT	8031+61.63	14.7' LT	425.9
8023+05.45	.8' RT	8033+35.98	9.7' RT	715.0
8033+34.59	16.5' RT	8036+79.66	13.1' RT	133.3
<b>PROJECT TOTAL</b>				<b>21,348</b>

CHAIN LINK FENCE REMOVAL				
STATION	OFFSET	STATION	OFFSET	QUANTITY (FOOT)
<b>EX I-55</b>				
243+89.38	91.0' RT	253+04.12	101.2' RT	915.1
253+04.12	101.2' RT	261+15.74	276.4' RT	837.1
261+15.74	276.4' RT	267+11.10	296.2' RT	607.5
267+11.10	296.2' RT	270+77.41	145.0' RT	395.8
270+77.41	145.0' RT	273+81.19	84.7' RT	309.7
273+81.19	84.7' RT	281+22.19	91.6' RT	730.1
281+18.54	126.9' RT	281+22.19	91.6' RT	35.5
281+22.19	91.6' RT	290+30.23	87.3' RT	893.9
288+17.80	250.3' LT	289+75.41	152.4' LT	162.6
289+75.41	152.4' LT	296+28.59	149.0' LT	680.5
290+30.23	87.3' RT	299+68.40	91.3' RT	923.8
296+28.59	149.0' LT	300+99.44	147.3' LT	501.7
319+81.82	146.9' LT	319+87.01	93.3' LT	53.9
319+87.01	93.3' LT	328+09.98	102.5' LT	823.1
<b>EX SEIL RD</b>				
4012+74.13	60.0' LT	4015+92.67	81.1' LT	319.2
4015+92.67	81.1' LT	4015+95.08	65.7' LT	15.7
4015+95.08	65.7' LT	4016+79.80	75.8' LT	85.0
4016+79.80	75.8' LT	4017+68.60	130.0' LT	105.0
4017+68.60	130.0' LT	4017+77.14	162.8' RT	33.9
<b>EX IL RTE 59 SB</b>				
7001+34.52	158.9' RT	7003+51.36	96.9' RT	225.5
7001+41.39	241.7' RT	7001+34.52	158.9' RT	83.1
7003+51.36	96.9' RT	7010+99.21	57.0' RT	749.5
7010+99.21	57.0' RT	7011+01.40	38.6' RT	18.5
7011+01.40	38.6' RT	7012+05.13	37.8' RT	108.4
7012+05.13	37.8' RT	7015+55.07	35.1' RT	364.9
7015+55.07	35.1' RT	7019+23.44	34.1' RT	382.4
<b>PROJECT TOTAL</b>				<b>10,362</b>

WOVEN WIRE FENCE REMOVAL				
STATION	OFFSET	STATION	OFFSET	QUANTITY (FOOT)
<b>EX I-55</b>				
281+18.54	126.9' RT	289+41.63	385.9' RT	837.0
289+41.63	385.9' RT	299+63.02	94.4' RT	1,028.9
299+63.02	94.4' RT	330+55.73	146.3' RT	3,094.4
<b>PROJECT TOTAL</b>				<b>4,962</b>

GUARDRAIL REMOVAL				
STATION	OFFSET	STATION	OFFSET	QUANTITY (FOOT)
<b>EX I-55</b>				
290+70.68	56.4' LT	293+63.94	56.6' LT	296.1
245+94.23	70.1' RT	248+32.18	69.6' RT	238.0
<b>EX SEIL RD</b>				
4012+78.93	23.1' RT	4014+07.97	22.1' RT	129.0
4015+39.75	23.4' RT	4017+97.75	63.3' RT	274.8
<b>EX IL RTE 59 SB</b>				
7000+75.73	19.4' RT	7004+58.75	14.9' RT	383.1
<b>EX IL RTE 59</b>				
7474+31.42	39.9' RT	7479+56.30	40.8' RT	524.9
7475+60.14	240.2' LT	7479+52.08	38.3' LT	526.1
<b>EX IL RTE 59 NB</b>				
8010+69.63	12.0' RT	8019+12.69	7.5' RT	850.6
8010+65.72	24.0' LT	8019+00.88	19.9' LT	816.2
8023+10.50	8.1' RT	8035+07.42	12.9' RT	1,189.8
8022+85.13	20.4' LT	8031+57.99	19.2' LT	890.8
<b>PROJECT TOTAL</b>				<b>6,120</b>

MODEL: Default  
 FILE: \\na16c-pub\ubeneech-pub\ent\by.com\benesch-pw\01\Documents\10700510740\_000\Eng\_Docs\_Phase II\Removal\_H\_Thomas\10700510740\_000\Eng\_Docs\_Phase II\Removal\_H\_Thomas\10700510740\_000\RemovalSchedule-04.dgn



USER NAME = VinceM	DESIGNED - KYLEVZ	REVISED -
PLOT SCALE = 2,000' / in.	CHECKED - BPAWULA	REVISED -
PLOT DATE = 3/10/2022	DATE - 03/16/2022	REVISED -

**STATE OF ILLINOIS  
DEPARTMENT OF TRANSPORTATION**

**SCHEDULE OF QUANTITIES  
REMOVALS**

SCALE: SHEET OF SHEETS STA. Sta TO STA. ToSta

F.A./P RTE.	SECTION	COUNTY	TOTAL SHEETS	SHEET NO.
*	2018-075-R	WILL	1510	83
				CONTRACT NO. 62H15
* FAI 55, FAP 338 ILLINOIS FED. AID PROJECT				



TEMPORARY PAVEMENT		TEMPORARY PAVEMENT	SUBBASE GRANULAR MATERIAL, TYPE B 4"
STAGE	ROADWAY	SQ YD	SQ YD
PRE-STAGE	IL 59 / RAMP D	1,800	1,800
STAGE 1	IL 59 / RAMP D	1,945	1,945
	RAMP C	2,389	2,389
	SEIL ROAD	2,784	2,784
	W. FRONTAGE	845	845
SUB-STAGE 2	I-55	278	278
STAGE 2	SEIL ROAD	239	239

TOTAL:	10,280	10,280
--------	--------	--------

**STATE OF ILLINOIS  
DEPARTMENT OF TRANSPORTATION**

**SCHEDULE OF QUANTITIES  
MAINTENANCE OF TRAFFIC**

SCALE: NO SCALE SHEET OF SHEETS STA. TO STA.

F.A./P RTE.	SECTION	COUNTY	TOTAL SHEETS	SHEET NO.
*	2018-075-R	WILL	1510	85
CONTRACT NO. 62H15				
* FAI 55, FAP 338 ILLINOIS FED. AID PROJECT				

MODEL: Default  
 FILE: M:\MFC - Proj\benesch-pw-bentley.com\benesch-pw-01\Documents\170205\10740\_001\Eng\_Docs\_Phase\_1\General\162H15-shi-schedule-24.dgn  
 D:\62H15-shi-schedule-24.dgn  
 50.107  
 2012/11/30



USER NAME = nReynolds	DESIGNED -	REVISED -
	DRAWN -	REVISED -
PLOT SCALE = 24,0000 * / ft.	CHECKED -	REVISED -
PLOT DATE = 2/8/2022	DATE - 02/04/2022	REVISED -

AGGREGATE SUBGRADE IMPROVEMENT 12"				
ROADWAY URBAN - 90% FED/10% STATE				
ROADWAY	ALIGNMENT	STATION START	STATION END	AREA (SQ YD)
I-55	EXI55_MLCL	276+41.69	337+23.89	18,838
I-55	EXI55_MLCL	283+78.31	330+10.54	11,787
IL RTE 59	PrBL59SBNorth	7992+42.26	8000+71.91	7,377
SEIL RD / WFR	EXSEILRDCL	4003+64.76	4018+15.35	12,342
IL RTE 59 NB	PR59BLDDINB	8000+71.91	8016+24.29	9,194
IL RTE 59 NB	PR59BLDDINB	8019+49.42	8021+30.95	610
IL RTE 59 SB	PR59BLDDISB	7000+67.40	7013+00.00	5,980
IL RTE 59 SB	PR59BLDDISB	7013+34.66	7015+65.92	796
IL RTE 59 SB	PR59BLDDISB	7019+74.26	7022+41.56	1,471
RAMP A NB	PR59RMPAN	1013+60.52	1016+12.61	826
RAMP A SB	PR59RMPAS	913+60.52	917+06.61	1,409
RAMP B NB	PR59RMPBNB	1128+41.19	1109+39.13	9,378
RAMP C NB	PR59RMPCNB	800+00.00	815+72.52	6,283
RAMP D NB	PR59RMPDNB	604+15.71	609+61.94	2,212
RAMP D SB	PR59RMPDSB	420+51.09	404+60.00	6,984
SUBTOTAL				95,487
ROADWAY URBAN - 100% JOLIET				
ROADWAY	ALIGNMENT	STATION START	STATION END	AREA (SQ YD)
IL RTE 59 NB	PR59BLDDINB	8021+31.06	8036+09.39	6,721
IL RTE 59 SB	PR59BLDDISB	7022+42.10	7023+71.46	414
IL RTE 59 SB	PR59BLDDISB	7023+82.91	7037+70.26	6,569
RAMP B NB	PR59RMPBNB	1107+04.67	1109+44.81	877
RAMP D SB	PR59RMPDSB	700+65.85	707+97.74	2,761
ROCK RUN CROSSINGS DR	PREAFRRD3	6057+89.82	6098+12.14	18,904
SUBTOTAL				36,246
GRAND TOTAL				131,733

SUBBASE GRANULAR MATERIAL, TYPE B 6"				
SHARED-USE PATH - 80% FED/20% STATE				
ROADWAY	ALIGNMENT	STATION START	STATION END	AREA (SQ YD)
IL-59	PR IL RTE 59 SB	6992+32.80	6999+20.32	763
SEIL RD	EX CL SEIL RD	4012+64.31	4017+98.20	587
IL-59	PR IL RTE 59 NB	8000+00.00	8009+60.15	1,086
IL-59	PR IL RTE 59 NB	8024+09.90	8035+62.12	1,302
SUBTOTAL				3,738
SHARED-USE PATH - 100% SHOREWOOD				
ROADWAY	ALIGNMENT	STATION START	STATION END	AREA (SQ YD)
SEIL RD	EX CL SEIL RD	4003+87.65	4011+84.37	710
SUBTOTAL				710
GRAND TOTAL				4,448

AGGREGATE SHOULDERS, TYPE B 10"						
ROADWAY URBAN - 90% FED/10% STATE						
ROADWAY	ALIGNMENT	STATION START	OFFSET (LT/RT)	STATION END	OFFSET (LT/RT)	AREA (SQ YD)
I-55	EXI55_MLCL	280+13.66	RT	303+79.63	RT	777
I-55	EXI55_MLCL	283+00.00	LT	285+23.83	LT	74
I-55	EXI55_MLCL	289+19.53	LT	336+98.75	LT	1599
I-55	EXI55_MLCL	306+12.36	RT	330+09.48	RT	799
RAMP A NB	PR59RMPAN	900+56.42	RT	907+01.45	RT	215
RAMP A NB	PR59RMPAN	904+54.82	LT	907+75.09	LT	109
RAMP A NB	PR59RMPAN	907+21.45	RT	913+38.45	RT	206
RAMP B NB	PR59RMPBNB	1108+77.40	LT	1121+19.49	LT	314
RAMP B NB	PR59RMPBNB	1109+83.68	RT	1118+78.24	RT	298
RAMP C NB	PR59RMPCNB	800+00.00	RT	802+00.00	RT	67
RAMP C NB	PR59RMPCNB	806+12.20	LT	810+35.66	LT	181
RAMP D NB	PR59RMPDNB	603+04.54	LT	610+64.04	LT	245
RAMP D SB	PR59RMPDSB	402+58.26	RT	420+51.09	RT	601
RAMP D SB	PR59RMPDSB	413+93.76	LT	420+51.09	LT	219
IL 59 SB	PrBL59DDINB	8019+68.64	LT	8020+90.7	LT	30
I-55	EXI55_MLCL	336+23.17	LT	337+23.33	LT	53
SUBTOTAL						5,787
ROADWAY URBAN - 100% JOLIET						
ROADWAY	ALIGNMENT	STATION START	OFFSET (LT/RT)	STATION END	OFFSET (LT/RT)	AREA (SQ YD)
RAMP C SB	PR59RMPCSB	703+25.00	RT	704+95.01	RT	57
SUBTOTAL						57
GRAND TOTAL						5,844

SUBBASE GRANULAR MATERIAL, TYPE B 4"						
SHARED-USE PATH - 90% FED/10% STATE						
ROADWAY	ALIGNMENT	STATION START	OFFSET (LT/RT)	STATION END	OFFSET (LT/RT)	AREA (SQ YD)
IL-59	PR IL RTE 59 SB	6991+68.43	29.35 RT	6992+07.01	61.98 RT	110
Seil Rd	EX CL SEIL RD	4006+08.63	11.71 RT	4006+48.46	10.58 RT	42
Seil Rd	EX CL SEIL RD	4006+85.91	9.51 RT	4007+32.89	9.90 RT	59
Seil Rd	EX CL SEIL RD	4007+87.61	14.76 RT	4008+27.61	18.32 RT	77
Seil Rd	EX CL SEIL RD	4003+99.09	14.58 RT	4004+46.11	14.58 RT	50
Seil Rd	EX CL SEIL RD	4005+13.07	14.44 RT	4005+61.53	13.06 RT	52
Seil Rd	EX CL SEIL RD	4011+97.82	36.56 LT	4012+59.28	41.83 RT	230
WEST FRONTAGE RD	EXWESTFRRD	5541+70.08	23.44 RT	5544+36.21	474.35 RT	1,297
Ramp A	PR59RMPAS	907+01.45	8.0 RT	907+51.45	97.15 RT	384
SUBTOTAL						2,301
SHARED-USE PATH - 100% JOLIET						
ROADWAY	ALIGNMENT	STATION START	OFFSET (LT/RT)	STATION END	OFFSET (LT/RT)	AREA (SQ YD)
ROCK RUN CROSSINGS	PREAFRONTTRD	6089+12.69	12.75 RT	8035+62.12	10.80 RT	119
SUBTOTAL						119
TOTAL						2,420
GRAND TOTAL						12,700

**NOTE: ADDITIONAL QUANTITY USED FOR TEMPORARY PAVEMENT BASE. SEE MOT SCHEDULES FOR ADDITIONAL QUANTITY.**

PORTLAND CEMENT CONCRETE PAVEMENT 10" JOINTED				
ROADWAY URBAN - 90% FED/10% STATE				
ROADWAY	ALIGNMENT	STATION START	STATION END	AREA (SQ YD)
IL-59	PR BL IL RTE 59 SB	6992+37.74	7000+67.39	6,126
SEIL RD	EX CL SEIL RD	4016+17.07	4018+19.03	2,015
IL-59	PR BL IL RTE 59 NB	8000+71.91	8015+38.14	7,608
IL-59	PR BL IL RTE 59 SB	7000+67.40	7012+73.90	4,834
IL-59	PR BL IL RTE 59 SB	7013+33.41	7015+65.92	655
RAMP D	PR BL RAMP D SB	404+47.50	412+87.67	1,477
RAMP D	PR BL RAMP D NB	603+96.89	609+66.04	1,053
RAMP A	PR BL RAMP A NB	1013+60.52	1016+12.61	703
RAMP A	PR BL RAMP A SB	913+60.52	917+06.61	1,150
IL-59	PR BL IL RTE 59 NB	8020+20.08	8021+31.06	518
IL-59	PR BL IL RTE 59 SB	7019+99.36	7022+41.56	1,087
RAMP C	PR BL RAMP C NB	810+51.58	815+54.41	1,530
RAMP B	PR BL RAMP B SB	1202+68.07	1205+20.83	473
RAMP B	PR BL RAMP B NB	1109+39.13	1109+56.18	20
SUBTOTAL				29,249
ROADWAY URBAN - 100% JOLIET				
ROADWAY	ALIGNMENT	STATION START	STATION END	AREA (SQ YD)
RAMP C	PR BL RAMP C SB	705+06.74	707+69.10	973
RAMP B	PR BL RAMP B NB	1106+94.06	1109+44.66	460
IL-59	PR BL IL RTE 59 NB	8021+31.06	8035+99.45	5,427
IL-59	PR BL IL RTE 59 SB	7022+41.56	7023+71.54	351
IL-59	PR BL IL RTE 59 SB	7023+81.73	7037+60.16	5,324
ROCK RUN	PR CL ROCK RUN CROSSING	6057+89.82	6059+42.92	1,012
SUBTOTAL				13,547
GRAND TOTAL				42,796

PORTLAND CEMENT CONCRETE SHOULDERS 10"				
ROADWAY URBAN - 90% FED/10% STATE				
ROADWAY	ALIGNMENT	STATION START	STATION END	AREA (SQ YD)
RAMP D	PR RAMP D SB	402+50.05	412+87.67	922
RAMP D	PR RAMP D SB	404+47.50	412+87.67	545
RAMP D	PR RAMP D NB	602+96.88	609+65.85	438
RAMP D	PR RAMP D NB	603+96.89	609+66.04	557
RAMP B	PR RAMP B SB	1200+99.51	1205+20.83	256
RAMP B	PR RAMP B SB	1202+68.07	1205+20.83	254
RAMP B	PR RAMP B NB	1109+44.66	1109+56.18	8
RAMP B	PR RAMP B NB	1109+44.66	1109+56.18	10
SUBTOTAL				2,990
ROADWAY URBAN - 100% JOLIET				
ROADWAY	ALIGNMENT	STATION START	STATION END	AREA (SQ YD)
RAMP B	PR RAMP B NB	1106+94.06	1109+44.66	180
RAMP B	PR RAMP B NB	1108+04.11	1109+44.66	116
RAMP C	PR RAMP C SB	706+00.00	7028+70.35	367
SUBTOTAL				663
GRAND TOTAL				3,653

PAVEMENT CONNECTOR (PCC) FOR BRIDGE APPROACH SLAB				
ROADWAY URBAN - 90% FED/10% STATE				
ROADWAY	ALIGNMENT	STATION START	STATION END	AREA (SQ YD)
IL-59	PR BL IL RTE 59 NB	7015+65.92	7015+89.54	51
IL-59	PR BL IL RTE 59 NB	7019+75.52	7019+99.36	57
IL-59	PR BL IL RTE 59 SB	8015+38.14	8016+09.74	280
IL-59	PR BL IL RTE 59 SB	8019+55.75	8020+20.08	139
SUBTOTAL				527

M:\REL - Default -\Alfred Benesch, Inc.\Projects\62215\Drawings\62215-RTE-Schedule17.dgn  
 FILE: M:\REL - Default -\Alfred Benesch, Inc.\Projects\62215\Drawings\62215-RTE-Schedule17.dgn



USER NAME = nReynolds	DESIGNED -	REVISED -
DRAWN -	REVISED -	
PLOT SCALE = 24.0000' / 1 ft.	CHECKED -	REVISED -
PLOT DATE = 2/8/2022	DATE = 02/04/2022	REVISED -

**STATE OF ILLINOIS  
DEPARTMENT OF TRANSPORTATION**

**SCHEDULE OF QUANTITIES  
PCC PAVEMENT, DRIVEWAY & SHOULDER**

SCALE: NO SCALE SHEET OF SHEETS STA. TO STA.

F.A./P. RTE.	SECTION	COUNTY	TOTAL SHEETS	SHEET NO.
*	2018-075-R	WILL	1510	87
			CONTRACT NO. 62H15	
* FAI 55, FAP 338		ILLINOIS FED. AID PROJECT		

HOT-MIX ASPHALT PAVEMENT (FULL-DEPTH), 9"						
100% JOLIET						
ROADWAY	ALIGNMENT	STATION START	OFFSET (LT/RT)	STATION END	OFFSET (LT/RT)	AREA (SQ YD)
ROCK RUN CROSSING	PREAFRONTRD	6059+41.47	(40.07/40.44)	6097+27.85	(12.0/12.0)	13,821
ROCK RUN CROSSING	INTERSECTION OF COUNTY FARM ROAD					1,008
SUBTOTAL						14,829

HOT-MIX ASPHALT PAVEMENT (FULL-DEPTH), 10.25"						
ROADWAY URBAN - 90% FED/10% STATE						
ROADWAY	ALIGNMENT	STATION START	OFFSET (LT/RT)	STATION END	OFFSET (LT/RT)	AREA (SQ YD)
SEIL	EXSEILRDCL	4003+89.75	(16.55/12.00)	4016+17.07	(48.0/30.0)	6,533
West Frontage	EXWESTFRRD	5541+86.66	(18.28/22.49)	5544+69.94	(86.16/128.05)	1,970
SUBTOTAL						8,503

HOT-MIX ASPHALT PAVEMENT (FULL-DEPTH), 12 3/4"						
ROADWAY URBAN - 90% FED/10% STATE						
ROADWAY	ALIGNMENT	STATION START	OFFSET (LT/RT)	STATION END	OFFSET (LT/RT)	AREA (SQ YD)
RAMP A	PR59RMPAS	900+56.42	(16.0/0.0)	913+60.52	(26.56/0.0)	2,801
RAMP B	PR59RMPBN	1109+56.18	(16.0/0.0)	1128+41.19	(16.00/0.0)	4,167
RAMP B	PR59RMPBS	1205+20.83	(16.0/0.0)	1207+65.57	(16.0/0.0)	458
RAMP C	PR59RMPDN	800+00.00	(12.0/0.0)	810+51.58	(28.0/24.0)	2,715
RAMP D	PR59RMPDS	412+87.67	(16.0/0)	420+51.09	(16.0/0.0)	2,165
RAMP D	PR59RMPDN	609+66.04	(0.0/16.0)	610+61.57	(0.0/16.0)	173
US 52 RAMP D	PRUS52RMPD	200+67.70	(16.0/0.0)	205+61.00	(0.0/16.0)	880
SUBTOTAL						13,360

100% JOLIET						
ROADWAY	ALIGNMENT	STATION START	OFFSET (LT/RT)	STATION END	OFFSET (LT/RT)	AREA (SQ YD)
RAMP C	PR59RMPDN	806+09.87	(0.0/5.3)	810+51.58	(0.0/24.0)	935
SUBTOTAL						935
GRAND TOTAL						14,295

HOT MIX ASPHALT PAVEMENT (FULL DEPTH), 15"						
ROADWAY URBAN - 90% FED/10% STATE						
ROADWAY	ALIGNMENT	STATION START	OFFSET (LT/RT)	STATION END	OFFSET (LT/RT)	AREA (SQ YD)
I-55	EXCL55	298+17.81	60.06 to 44.22 LT	332+08.54	64.14 to 44.13 LT	5,939
I-55	EXCL55	283+78.31	43.75 to 59.74 RT	330+10.54	43.87 to 55.87 RT	6,208
TOTAL						12,147

HOT-MIX ASPHALT SHOULDER, 12 3/4"						
ROADWAY URBAN - 90% FED/10% STATE						
ROADWAY	ALIGNMENT	STATION START	OFFSET (LT/RT)	STATION END	OFFSET (LT/RT)	AREA (SQ YD)
RAMP A	PR59RMPAS	900+56.37	0.0 to 8.0 RT	913+49.21	12.0 RT	1146
RAMP A	PR59RMPAS	900+56.42	16.0 LT	907+83.86	16.0 LT	1297
RAMP B	PR59RMPBN	1109+56.18	8.0 RT	1128+41.19	8.0 RT	1571
RAMP B	PR59RMPBN	1112+64.16	38.0 LT	1128+41.19	16.0 LT	1391
RAMP B	PR59RMPBS	1205+20.83	6.0 LT	1207+65.57	6.0 LT	160
RAMP C	PR59RMPDN	802+44.18	24.0 LT	810+41.38	27.82 LT	996
RAMP C	PR59RMPDN	800+00.00	13.84 RT	806+09.73	0.0 to 13.3 RT	580
RAMP D	PR59RMPDS	412+87.67	7.93 RT	420+51.09	8.0 RT	679
RAMP D	PR59RMPDS	413+93.76	43.92 LI	420+51.09	22.0 LI	439
RAMP D	PR59RMPDN	609+66.04	6.0 LT	610+64.04	6.0 LT	65
US 52 RAMP D	PRUS52RMPD	200+66.04	16.0 LT	205+61.00	16.0 LT	568
US 52 RAMP D	PRUS52RMPD	200+68.24	8.0 RT	205+61.00	8.0 RT	438
SUBTOTAL						9329

100% JOLIET						
ROADWAY	ALIGNMENT	STATION START	OFFSET (LT/RT)	STATION END	OFFSET (LT/RT)	AREA (SQ YD)
RAMP C	PR59RMPDN	806+09.73	0.0 to 13.3 RT	810+51.58	32.0 RT	391
SUBTOTAL						391
GRAND TOTAL						9,720

HOT-MIX ASPHALT SHOULDERS, 15"						
ROADWAY URBAN - 90% FED/10% STATE						
ROADWAY	ALIGNMENT	STATION START	OFFSET (LT/RT)	STATION END	OFFSET (LT/RT)	AREA (SQ YD)
I-55	EXCL55	289+19.61	60.06 to 68.03 LT	332+08.54	64.14 to 44.13 LT	4,696
I-55	EXCL55	283+78.63	59.74 to 67.73 RT	330+09.96	55.87 to 65.87 RT	5,067
I-55	EXCL55	218+44.00	8.00 LT	218+96.00	8.00 LT	38
I-55	EXCL55	218+44.00	8.00 RT	218+96.00	8.00 RT	38
I-55	EXCL55	233+64.00	8.00 LT	234+16.00	8.00 LT	38
I-55	EXCL55	233+64.00	8.00 RT	234+16.00	8.00 RT	38
I-55	EXCL55	248+37.00	8.00 LT	248+89.00	8.00 LT	38
I-55	EXCL55	248+37.00	8.00 RT	248+89.00	8.00 RT	38
I-55	EXCL55	290+14.00	8.00 LT	290+66.00	8.00 LT	38
I-55	EXCL55	290+14.00	8.00 RT	290+66.00	8.00 RT	38
I-55	EXCL55	314+54.00	8.00 LT	315+06.00	8.00 LT	38
I-55	EXCL55	314+54.00	8.00 RT	315+06.00	8.00 RT	38
I-55	EXCL55	355+24.00	8.00 LT	355+76.00	8.00 LT	38
I-55	EXCL55	355+24.00	8.00 RT	355+76.00	8.00 RT	38
I-55	EXCL55	375+74.00	8.00 LT	376+28.00	8.00 LT	38
I-55	EXCL55	375+74.00	8.00 RT	376+28.00	8.00 RT	38
TOTAL						10,289

HOT-MIX ASPHALT DRIVEWAY PAVEMENT, 8"						
ROADWAY URBAN - 90% FED/10% STATE						
ROADWAY	ALIGNMENT	STATION START	OFFSET (LT/RT)	STATION END	OFFSET (LT/RT)	AREA (SQ YD)
SEIL	EXSEILRDCL	4006+08.63	11.71 RT	4006+48.46	10.58 RT	42
SEIL	EXSEILRDCL	4006+85.91	9.51 RT	4007+32.89	9.90 RT	59
SEIL	EXSEILRDCL	4007+87.61	14.76 RT	4008+27.61	18.32 RT	77
TOTAL						179

HOT-MIX ASPHALT DRIVEWAY PAVEMENT, 10"						
ROADWAY URBAN - 90% FED/10% STATE						
ROADWAY	ALIGNMENT	STATION START	OFFSET (LT/RT)	STATION END	OFFSET (LT/RT)	AREA (SQ YD)
SEIL	EXSEILRDCL	4003+99.09	14.58 RT	4004+46.11	14.58 RT	50
SEIL	EXSEILRDCL	4005+13.07	14.44 RT	4005+61.53	13.06 RT	52
SEIL	EXSEILRDCL	4011+97.82	36.56 LT	4012+59.28	41.83 LT	230
WEST FRONTAGE RD	EXWESTFRRD	5541+70.08	23.44 RT	5544+36.21	474.35 RT	1,297
RAMP A	PR59RMPAS	907+01.45	8.0 RT	907+51.45	97.15 RT	384
SUBTOTAL						2,013

100% JOLIET						
ROADWAY	ALIGNMENT	STATION START	OFFSET (LT/RT)	STATION END	OFFSET (LT/RT)	AREA (SQ YD)
ROCK RUN CROSSING	PREAFRONTRD	6089+12.69	12.75 RT	6089+31.04	10.80 RT	120
SUBTOTAL						120
GRAND TOTAL						2,133

M:\REL - Default - Pub\benesch.ppt.bentley.com\benesch.ppt.01\Documents\621115-rtb-schedule-18.dgn



USER NAME = nReynolds	DESIGNED -	REVISED -
	DRAWN -	REVISED -
PLOT SCALE = 24.0000' / 1'	CHECKED -	REVISED -
PLOT DATE = 2/8/2022	DATE - 02/04/2022	REVISED -

**STATE OF ILLINOIS  
DEPARTMENT OF TRANSPORTATION**

**SCHEDULE OF QUANTITIES  
HMA PAVEMENT, DRIVEWAY & SHOULDER**

SCALE: NO SCALE SHEET OF SHEETS STA. TO STA.

F.A.I.P. R.T.E.	SECTION	COUNTY	TOTAL SHEETS	SHEET NO.
*	2018-075-R	WILL	1510	88
			CONTRACT NO. 62H15	
* FAI 55, FAP 338		ILLINOIS FED. AID PROJECT		

D:\62115 sht schedule 18.dgn  
50107  
2012/11/30



COMBINATION CURB AND GUTTER, TYPE B-6.24						
ROADWAY URBAN - 90% FED/10% STATE						
ROADWAY	ALIGNMENT	STATION START	OFFSET (LT/RT)	STATION END	OFFSET (LT/RT)	LENGTH (FOOT)
IL RTE 59	PrBL59SBNorth	6992+37.74	47.49' LT	6999+85.96	56.00' LT	748
IL RTE 59	PrBL59SBNorth	6992+45.62	6.15' LT	6999+41.74	13.68' LT	697
IL RTE 59	PrBL59SBNorth	6992+45.62	0.25' LT	6999+41.74	2.00' LT	696
IL RTE 59	PrBL59SBNorth	6992+37.74	28.77' RT	6999+01.05	38.00' RT	664
SEIL RD	EXSEILRDCL	4003+75.40	42.46' LT	4018+43.35	105.22' LT	1,505
SEIL RD	EXSEILRDCL	4003+66.76	37.56' RT	4009+59.09	20.00' RT	607
SEIL RD	EXSEILRDCL	4010+71.28	13.20' RT	4011+71.23	9.98' RT	104
SEIL RD	EXSEILRDCL	4011+60.23	33.93' RT	4017+90.88	104.10' RT	681
W FRONTAGE RD	EXCLWFR	5540+43.19	20.17' LT	5544+69.85	56.21' LT	465
W FRONTAGE RD	EXCLWFR	5540+43.19	23.71' RT	5544+49.46	114.77' RT	445
IL RTE 59 NB	PR59BLDDINB	7999+90.48	38.00' LT	8009+68.15	44.00' LT	956
IL RTE 59 NB	PR59BLDDINB	8002+04.54	14.00' RT	8011+15.70	2.00' RT	913
IL RTE 59 NB	PR59BLDDINB	8010+26.23	44.00' LT	8011+67.70	44.00' LT	141
IL RTE 59 NB	PR59BLDDINB	8011+69.44	2.00' RT	8012+53.13	2.00' RT	84
IL RTE 59 NB	PR59BLDDINB	8013+61.05	26.86' RT	8016+22.28	4.40' RT	266
IL RTE 59 SB	PR59BLDDISB	7001+16.84	38.00' RT	7005+43.12	57.70' RT	419
IL RTE 59 SB	PR59BLDDISB	7002+00.03	2.00' LT	7012+64.06	7.13' LT	1,066
IL RTE 59 SB	PR59BLDDISB	7007+35.49	30.00' RT	7013+02.07	30.88' RT	609
IL RTE 59 SB	PR59BLDDISB	7013+33.36	2.88' LT	7014+56.01	2.00' LT	123
IL RTE 59 SB	PR59BLDDISB	7019+74.81	1.03' LT	7021+78.04	32.41' LT	209
RAMP A SB	PR59RMPAS	914+48.30	2.00' RT	916+93.57	7.33' RT	251
RAMP A SB	PR59RMPAS	913+60.52	28.56' LT	END ALI	30.00' LT	405
RAMP A NB	PR59RMPAN	1013+34.99	13.75' RT	1016+12.61	2.00' RT	275
RAMP A NB	PR59RMPAN	1014+33.42	29.00' LT	1015+82.27	33.26' LT	180
RAMP B SB	PR59RMPBSB	1202+76.58	26.00' RT	1205+19.53	28.98' RT	297
RAMP C NB	PR59RMPCNB	810+33.61	38.99' LT	END ALI	30.00' LT	610
RAMP C NB	PR59RMPCNB	811+81.47	2.00' RT	815+53.15	5.07' RT	384
RAMP D NB	PR59RMPDSB	604+14.93	26.00' RT	609+64.72	28.99' RT	621
RAMP D SB	PR59RMPDSB	404+60.11	24.00' RT	412+83.15	24.00' RT	803
SUBTOTAL						15,226
ROADWAY URBAN - 100% JOLIET						
ROADWAY	ALIGNMENT	STATION START	OFFSET (LT/RT)	STATION END	OFFSET (LT/RT)	LENGTH (FOOT)
IL RTE 59 NB	PR59BLDDINB	8021+31.06	2.00' RT	8022+15.49	3.87' RT	85
IL RTE 59 NB	PR59BLDDINB	8022+27.82	30.00' LT	8024+33.37	30.00' LT	210
IL RTE 59 NB	PR59BLDDINB	8022+71.30	2.00' RT	8028+20.02	2.00' RT	548
IL RTE 59 NB	PR59BLDDINB	8024+50.56	59.94' LT	8028+19.65	44.00' LT	377
IL RTE 59 SB	PR59BLDDISB	7022+41.68	2.00' LT	7023+73.04	3.87' LT	133
IL RTE 59 SB	PR59BLDDISB	7023+85.37	30.00' RT	7026+33.41	30.00' RT	262
IL RTE 59 SB	PR59BLDDISB	7024+26.92	7.30' LT	7029+80.11	2.00' LT	558
IL RTE 59 SB	PR59BLDDISB	7027+25.92	43.40' RT	7029+78.55	26.00' RT	250
RAMP C SB	PR59RMPCSB	704+89.82	15.14' RT	707+99.91	10.00' RT	291
RAMP C SB	PR59RMPCSB	706+24.82	32.00' LT	707+28.21	45.62' LT	140
RAMP B NB	PR59RMPBNS	1107+04.03	24.00' RT	1109+44.58	24.00' RT	264
RAMP B NB	PR59RMPBNS	1106+94.05	2.00' LT	1108+04.11	2.00' LT	109
GATEWAY BLVD	PR59BLDDINB	8028+19.65	44.00' LT	8036+07.41	96.43' LT	829
GATEWAY BLVD	PR59BLDDINB	8028+20.02	2.00' RT	8033+50.98	2.00' RT	531
GATEWAY BLVD	PR59BLDDINB	8028+20.23	29.86' RT	8033+50.98	10.00' RT	532
GATEWAY BLVD	PR59BLDDINB	8028+20.44	57.90' RT	8036+17.16	118.17' RT	825
ROCK RUN CROSSING DR	PREFRRD3	6059+80.52	32.00' LT	EAST FRONTAGE RD	0.00' LT	3,933
ROCK RUN CROSSING DR	PREFRRD3	6057+65.91	20.00' RT	COUNTY LINE RD	0.00' RT	4,149
ROCK RUN CROSSING DR	PREFRRD3	EAST FRONTAGE RD	0.00' LT	EAST FRONTAGE RD	0.00' RT	175
SUBTOTAL						14,200
GRAND TOTAL						29,427

COMBINATION CURB AND GUTTER, TYPE B-6.06						
ROADWAY URBAN - 90% FED/10% STATE						
ROADWAY	ALIGNMENT	STATION START	OFFSET (LT/RT)	STATION END	OFFSET (LT/RT)	LENGTH (FOOT)
SEIL RD	EXSEILRDCL	4010+77.16	63.00' RT	4011+69.31	12.00' RT	120
TOTAL						120

COMBINATION CONCRETE CURB AND GUTTER, TYPE B-6.12						
ROADWAY URBAN - 90% FED/10% STATE						
ROADWAY	ALIGNMENT	STATION START	OFFSET (LT/RT)	STATION END	OFFSET (LT/RT)	LENGTH (FOOT)
SEIL RD	SEIL_RD	4011+66.53	RT	4015+41.34	RT	379
SUBTOTAL						379

COMBINATION CONCRETE CURB AND GUTTER, TYPE M-4.12						
ROADWAY URBAN - 90% FED/10% STATE						
ROADWAY	ALIGNMENT	STATION START	OFFSET (LT/RT)	STATION END	OFFSET (LT/RT)	LENGTH (FOOT)
EAST FRONTAGE ROAD	EXEFRTOMCD ; EXEFRONTREXT2	16126+47.51	LT	16142+68.30	LT	1,628
TOTAL						1,628

COMBINATION CONCRETE CURB AND GUTTER, TYPE B-6.24 (VARIABLE WIDTH GUTTER FLAG)						
ROADWAY URBAN - 90% FED/10% STATE						
ROADWAY	ALIGNMENT	STATION START	OFFSET (LT/RT)	STATION END	OFFSET (LT/RT)	LENGTH (FOOT)
W FRONTAGE ROAD	EXCLWFR	5544+22.99	27.00' RT	5544+74.15	26.10' RT	52
TOTAL						52

COMBINATION CONCRETE CURB AND GUTTER, TYPE B-9.24						
ROADWAY URBAN - 90% FED/10% STATE						
ROADWAY	ALIGNMENT	STATION START	OFFSET (LT/RT)	STATION END	OFFSET (LT/RT)	LENGTH (FOOT)
IL RTE 59 NB	PR59BLDDINB	8012+21.45	44.00' LT	8015+27.39	44.00' LT	293
IL RTE 59 NB	PR59BLDDINB	8019+80.59	35.13' LT	8021+31.06	30.00' LT	143
IL RTE 59 SB	PR59BLDDISB	7013+70.72	31.85' RT	7015+70.32	26.63' RT	189
IL RTE 59 SB	PR59BLDDISB	7020+31.02	30.00' RT	7022+41.57	30.00' RT	203
SUBTOTAL						828
ROADWAY URBAN - 100% JOLIET						
ROADWAY	ALIGNMENT	STATION START	OFFSET (LT/RT)	STATION END	OFFSET (LT/RT)	LENGTH (FOOT)
IL RTE 59 NB	PR59BLDDINB	8021+31.06	30.00' LT	8021+68.81	35.30' LT	43
IL RTE 59 SB	PR59BLDDISB	7022+41.56	30.00' RT	7023+24.44	30.00' RT	79
SUBTOTAL						122
GRAND TOTAL						950

COMBINATION CURB AND GUTTER, TYPE M-4.24						
ROADWAY URBAN - 90% FED/10% STATE						
ROADWAY	ALIGNMENT	STATION START	OFFSET (LT/RT)	STATION END	OFFSET (LT/RT)	LENGTH (FOOT)
RAMP A SB	PR59RMPAS	907+70.13	26.92' LT	913+60.52	28.56' LT	590
TOTAL						590

CONCRETE GUTTER, TYPE B						
ROADWAY URBAN - 90% FED/10% STATE						
ROADWAY	ALIGNMENT	STATION START	OFFSET (LT/RT)	STATION END	OFFSET (LT/RT)	LENGTH (FOOT)
I-55	EXCL55	272+24.00	LT	279+35.00	LT	720
SEIL ROAD	EXSEILRDCL	4013+65.00	RT	4015+80.00	RT	215
TOTAL						935

CONCRETE MEDIAN, TYPE SB-6.12				
ROADWAY URBAN - 90% FED/10% STATE				
ROADWAY	ALIGNMENT	STATION START	STATION END	AREA (SQ FT)
SEIL RD	EXSEILRDCL	4014+33.06	4016+17.07	1,075
TOTAL				1,075

CONCRETE MEDIAN, TYPE SB-6.24				
ROADWAY URBAN - 90% FED/10% STATE				
ROADWAY	ALIGNMENT	STATION START	STATION END	AREA (SQ FT)
IL RTE 59	PrBL59SBNorth	7992+37.26	7992+50.11	118
IL RTE 59	PrBL59SBNorth	7999+46.25	7999+62.29	210
RAMP D SB	PR59RMPDSB	404+47.50	404+60.38	133
RAMP A SB	PR59RMPAS	914+40.51	914+49.02	79
IL RTE 59 NB	PR59BLDDINB	8012+52.83	8012+71.18	171
IL RTE 59 SB	PR59BLDDISB	7022+31.40	7022+42.10	105
SUBTOTAL				816

ROADWAY URBAN - 100% JOLIET				
ROADWAY	ALIGNMENT	STATION START	STATION END	AREA (SQ FT)
IL RTE 59 NB	PR59BLDDINB	8024+33.05	8024+44.23	120
RAMP C NB	PR59RMPCNB	811+70.00	811+81.85	112
GATEWAY BOULEVARD	PR59BLDDINB	8033+50.98	8034+26.16	677
SUBTOTAL				909
GRAND TOTAL				1,725

CONCRETE MEDIAN, TYPE SB (SPECIAL)				
ROADWAY URBAN - 90% FED/10% STATE				
ROADWAY	ALIGNMENT	STATION START	STATION END	AREA (SQ FT)
IL RTE 59 NB	PR59BLDDINB	8000+71.91	8002+04.54	965
SEIL RD	EXSEILRDCL	4017+86.41	4016+17.07	1,017
SUBTOTAL				1,982
ROADWAY URBAN - 100% JOLIET				
ROADWAY	ALIGNMENT	STATION START	STATION END	AREA (SQ FT)
GATEWAY BOULEVARD	PR59BLDDINB	8034+26.16	8035+74.66	891
SUBTOTAL				891
GRAND TOTAL				2,873

CONCRETE MEDIAN SURFACE, 5 INCH				
ROADWAY URBAN - 90% FED/10% STATE				
ROADWAY	ALIGNMENT	STATION START	STATION END	AREA (SQ FT)
SEIL RD	EXSEILRDCL	4010+71.87	4011+70.65	1,519
IL RTE 59 NB	PR59BLDDINB	8019+68.65	8021+69.30	1,846
SUBTOTAL				3,365

STAMPED COLORED PORTLAND CEMENT CONCRETE MEDIAN SURFACE 6 INCH				
ROADWAY URBAN - 90% FED/10% STATE				
ROADWAY	ALIGNMENT	STATION START	STATION END	AREA (SQ FT)
IL RTE 59	PrBL59SBNorth	7992+50.13	7999+35.25	8631
SUBTOTAL				8,631

MODEL: Default  
 FILE: \\benesch-ar-bentley.com\benesch-ar\1\Documents\1\2020\10140\_001\Eng\_Docs\_Phase II\General\162H115-sh-schedule-19.dgn  
 D:\162H115-sh-schedule-19.dgn  
 50107  
 2012\11\30



USER NAME = nReynolds	DESIGNED -	REVISED -
PLOT SCALE = 2,0000' / in.	DRAWN -	REVISED -
PLOT DATE = 3/8/2022	CHECKED -	REVISED -
	DATE = 03/16/2022	REVISED -

**STATE OF ILLINOIS  
DEPARTMENT OF TRANSPORTATION**

**SCHEDULE OF QUANTITIES  
CURB & MEDIAN**

SCALE: NO SCALE SHEET OF SHEETS STA. TO STA.

F.A./P RTE.	SECTION	COUNTY	TOTAL SHEETS	SHEET NO.
*	2018-075-R	WILL	1510	89
CONTRACT NO. 62H15				
* FAY 55, FAP 338 ILLINOIS FED. AID PROJECT				

STEEL PLATE BEAM GUARDRAIL, 6 FOOT POSTS						HOT-MIX ASPHALT STABILIZATION 6" AT STEEL PLATE BEAM GUARD RAIL					TRAFFIC BARRIER TERMINAL, TYPE 1 (SPECIAL) TANGENT			TRAFFIC BARRIER TERMINAL, TYPE 2			TRAFFIC BARRIER TERMINAL, TYPE 6			TRAFFIC BARRIER TERMINAL, TYPE 10			TERMINAL MARKER - DIRECT APPLIED	GUARDRAIL REFLECTORS, TYPE A
STATION	OFFSET LT/RT	STATION	OFFSET LT/RT	Type A	Type B	STATION	OFFSET LT/RT	STATION	OFFSET LT/RT	AREA (SY)	STATION	OFFSET LT/RT	EACH	STATION	OFFSET LT/RT	EACH	STATION	OFFSET LT/RT	EACH	STATION	OFFSET LT/RT	LENGTH (FOOT)	EACH	EACH
				LENGTH (FOOT)	LENGTH (FOOT)																			

**ROADWAY URBAN - 90% FED/10% STATE**

<b>LOCATION 1 IL RTE 59 SB</b>																												
7020+00.15	27.61' RT	7021+38.15	30.58' RT	137.5		7019+87.00	26.03' RT	7021+51.51	30.58' RT	52				7021+51.51	30.58' RT	1				7019+87.00	26.03' RT	1		4				
<b>LOCATION 2 RAMP B</b>																												
1200+13.34	0.54' LT	1201+88.17	8.31' LT	175.0		1200+00.08	0.87' LT	1202+00.65	8.98' LT	61				1202+00.65	8.98' LT	1				1200+00.08	0.87' LT	1		4				
<b>LOCATION 3 RAMP A</b>																												
PR59RMPAS				PRBL59DDISB																								
909+53.70	18.53' LT	7015+14.68	11.83' LT	775.0		908+74.94	18.53' LT	7015+50.60	3.91' LT	277	909+02.97	19.30' LT	1				7015+50.60	3.91' LT	1				1	8				
<b>LOCATION 4 IL RTE 59 SB</b>																												
7014+77.88	30.58' RT	7015+32.65	30.14' RT	50.0		7013+91.69	30.58' RT	7015+70.97	27.17' RT	60	7014+22.02	31.59' RT	1				7015+70.97	27.17' RT	1				1	4				
<b>LOCATION 5 RAMP B</b>																												
1119+50.13	8.00' RT	1119+62.75	8.00' RT	12.5		1118+67.10	8.00' RT	1120+00.61	8.00' RT	43	1116+45.58	9.00' RT	1				1120+00.61	8.00' RT	1				1	4				
<b>LOCATION 7 E FRONTAGE ROAD</b>																												
16113+76.01	13.30' LT	16141+71.36	15.29' LT		2,800.0	16112+85.22	14.72' LT	16142+50.82	13.62' LT	1396	16113+26.03	16.85' LT	1										1	10				
											16142+20.16	14.94' LT	1										1					
<b>LOCATION 8 I55</b>																												
304+34.70	65.86' RT	306+09.70	65.87' RT	175.0		303+45.13	65.87' RT	306+22.20	65.87' RT	89	303+84.71	66.79' RT	1	306+22.20	65.87' RT	1							1	4				
<b>LOCATION 9 IL RTE 59 NB</b>																												
PRBL59DDINB				PR59RMPCNB																								
8020+41.14	10.13' RT	814+75.43	30.58' LT	150.0		8020+04.81	3.96' RT	813+89.30	30.58' LT	88	814+20.92	31.59' LT	1				8020+04.81	3.96' RT	1				1	4				
<b>LOCATION 11 RAMP B</b>																												
1109+44.66	8.00' RT	1110+92.46	8.00' RT	150.0		1109+44.66	8.00' RT	1111+04.49	8.00' RT	45				1111+04.49	8.00' RT	1								4				
<b>LOCATION 12 SEIL ROAD</b>																												
4012+50.56	27.38' RT	4017+25.03	32.58' RT	475.0		4011+66.98	35.85' RT	4017+37.53	32.66' RT	257	4012+00.92	33.41' RT	1	4017+37.53	32.58' RT	1							1	5				
<b>LOCATION 13 RAMP C</b>																												
PRRMP59CN				PRRMP59CS																								
801+47.67	8.00' RT	700+65.82	8.00' RT	462.5		800+64.51	10.69' RT	700+65.82	8.00' RT	158	800+97.70	9.60' RT	1										1	5				
<b>LOCATION 14 IL RTE 59 SB</b>																												
6994+36.88	30.17' RT	6998+99.13	30.58' RT	462.5		6993+46.94	27.18' RT	6999+01.05	38.58' RT	308	6993+86.97	27.12' RT	1	6999+01.05	39.56' RT	1							1	5				
<b>SUBTOTALS</b>				<b>3,025.0</b>	<b>2,800.0</b>						<b>2,834.0</b>				<b>10.0</b>				<b>6.0</b>				<b>4.0</b>			<b>2.0</b>	<b>10.0</b>	<b>61.0</b>

**ROADWAY URBAN - 100% JOLIET**

<b>LOCATION 6 ROCK RUN CROSSINGS DR</b>																												
6086+63.52	14.58' LT	6095+22.07	14.58' LT	875.0		6085+62.28	14.58' LT	6095+05.86	14.58' LT	335	6086+14.92	16.15' LT	1										1	5				
											6095+71.86	15.78' LT	1										1					
<b>LOCATION 10 RAMP B</b>																												
PRBL59DDINB				PR59RMPBN																								
8027+41.91	45.37' LT	1107+36.03	2.58' RT	300.0		8027+83.66	44.58' LT	1107+36.03	2.58' RT	227	8027+49.70	45.41' LT	1	1107+48.74	2.58' RT	1							1	4				
<b>LOCATION 11 RAMP B</b>																												
1107+61.83	20.80' RT	1110+92.46	8.00' RT	175.0		1107+43.65	18' RT	1110+92.46	8.00' RT	132				1107+49.76	20.49' RT	1								4				
<b>LOCATION 13 RAMP C</b>																												
700+65.82	8.00' RT	703+18.50	8.00' RT	250.0		700+65.82	8.00' RT	703+31.00	8.00' RT	82				703+31.00	8.00' RT	1								4				
<b>SUBTOTALS</b>				<b>1,600.0</b>	<b>0.0</b>						<b>776.0</b>				<b>3.0</b>				<b>3.0</b>				<b>0.0</b>			<b>0.0</b>	<b>3.0</b>	<b>17.0</b>
<b>GRAND TOTALS</b>				<b>4,625.0</b>	<b>2,800.0</b>						<b>3,610.0</b>				<b>13.0</b>				<b>9.0</b>				<b>4.0</b>			<b>2.0</b>	<b>13.0</b>	<b>78.0</b>

Model: Default  
 File: M:\bentley\pub\benesch\p1\2020\10740\_00\Eng\_Docs\_Phase\IGeneral\62H15-shr-schedule-20.dgn  
 D:\62H15-shr-schedule-20.dgn  
 50107  
 2012/11/30



USER NAME = nReynolds  
 DESIGNED -  
 DRAWN -  
 PLOT SCALE = 24.0000" / ft.  
 CHECKED -  
 DATE = 02/04/2022  
 PLOT DATE = 2/8/2022

REVISED -  
 REVISED -  
 REVISED -  
 REVISED -

**STATE OF ILLINOIS  
 DEPARTMENT OF TRANSPORTATION**

**SCHEDULE OF QUANTITIES  
 GUARDRAIL & SAFETY**

SCALE: NO SCALE SHEET OF SHEETS STA. TO STA.

F.A./P. RTE.	SECTION	COUNTY	TOTAL SHEETS	SHEET NO.
*	2018-075-R	WILL	1510	90
CONTRACT NO. 62H15				
* FAI 55, FAP 338 ILLINOIS FED. AID PROJECT				

SUBBASE GRANULAR MATERIAL, TYPE B 6"				
SHARED-USE PATH - 80% FED/20% STATE				
ROADWAY	ALIGNMENT	STATION START	STATION END	AREA (SQ YD)
IL-59	PRILRTE59SB	6992+32.80	6999+20.32	763
SEIL RD	EXCLSEILRD	4012+64.31	4017+98.20	587
IL-59	PRILRTE59NB	8000+00.00	8009+60.15	1,086
IL-59	PRILRTE59NB	8024+09.90	8035+62.12	1,302
SUBTOTAL				3,738
SHARED-USE PATH - 100% SHOREWOOD				
ROADWAY	ALIGNMENT	STATION START	STATION END	AREA (SQ YD)
SEIL RD	EXCLSEILRD	4003+87.65	4011+84.37	710
SUBTOTAL				710
GRAND TOTAL				4,448

HOT-MIX ASPHALT BINDER COURSE, IL-19.0, N50				
SHARED-USE PATH - 80% FED/20% SHOREWOOD				
ROADWAY	ALIGNMENT	STATION START	STATION END	QUANTITY (TON)
IL-59	PR IL RTE 59 SB	6992+32.80	6999+20.32	107
SEIL RD	EX CL SEIL RD	4012+64.31	4017+98.20	82
IL-59	PR IL RTE 59 NB	8000+00.00	8009+60.15	152
IL-59	PR IL RTE 59 NB	8024+09.90	8035+62.12	182
SUBTOTAL				523
SHARED-USE PATH - 80% FED/20% JOILET				
ROADWAY	ALIGNMENT	STATION START	STATION END	QUANTITY (TON)
SEIL RD	EX CL SEIL RD	4003+87.65	4011+84.37	99
SUBTOTAL				99
GRAND TOTAL				622

HOT-MIX ASPHALT SURFACE COURSE, IL-9.5, MIX "D", N50				
SHARED-USE PATH - 80% FED/20% STATE				
ROADWAY	ALIGNMENT	STATION START	STATION END	QUANTITY (TON)
IL-59	PR IL RTE 59 SB	6992+32.80	6999+20.32	64
SEIL RD	EX CL SEIL RD	4012+64.31	4017+98.20	49
IL-59	PR IL RTE 59 NB	7999+55.75	8009+60.15	91
IL-59	PR IL RTE 59 NB	8024+09.90	8035+62.12	109
SUBTOTAL				313
SHARED-USE PATH - 100% SHOREWOOD				
ROADWAY	ALIGNMENT	STATION START	STATION END	QUANTITY (TON)
SEIL RD	EX CL SEIL RD	4003+87.65	4011+84.37	60
SUBTOTAL				60
GRAND TOTAL				373

PORTLAND CEMENT CONCRETE SIDEWALK 8 INCH				
SHARED-USE PATH - 80% FED/20% STATE				
ROADWAY	ALIGNMENT	STATION START	STATION END	AREA (SQ FT)
SEIL RD	EXSEILRDCL	4011+84.37	4012+64.31	640
TOTAL				640

PORTLAND CEMENT CONCRETE SIDEWALK 5 INCH				
SHARED-USE PATH - 80% FED/20% STATE				
ROADWAY	ALIGNMENT	STATION START	STATION END	AREA (SQ FT)
IL-59	PR IL RTE 59 NB	8019+37.18	8021+53.23	2,045
IL-59	PR IL RTE 59 NB	8012+20.62	8015+51.60	3,058
IL-59	PR IL RTE 59 NB	8010+29.62	8011+84.20	1,667
IL-59	PR IL RTE 59 NB	8009+60.15	8009+92.18	283
IL-59	PR IL RTE 59 NB	7999+35.25	7999+55.75	275
IL-59	PR IL RTE 59 NB	7999+35.25	7999+46.25	127
IL-59	PR IL RTE 59 NB	7999+25.02	7999+53.00	448
IL-59	PR IL RTE 59 SB	6989+57.18	6989+78.63	109
IL-59	PR IL RTE 59 SB	6991+61.08	6991+79.03	114
IL-59	PR IL RTE 59 SB	6992+10.59	6992+32.90	207
IL-59	PR IL RTE 59 SB	6989+78.65	6991+61.08	1,248
IL-59	PR IL RTE 59 NB	8035+62.12	8035+85.91	368
IL-59	PR IL RTE 59 NB	8024+03.18	8024+15.47	289
IL-59	PR IL RTE 59 NB	8022+06.65	8023+81.78	1,977
SUBTOTAL				12,216
GRAND TOTAL				12,216

DETECTABLE WARNINGS				
SHARED-USE PATH - 100% JOILET				
ROADWAY	ALIGNMENT	STATION START	STATION END	AREA (SQ FT)
IL-59	PR IL RTE 59 NB	8023+95.05	8024+00.57	24
IL-59	PR IL RTE 59 NB	8023+76.05	8023+81.49	24
IL-59	PR IL RTE 59 SB	7023+47.27	7023+62.82	31
IL-59	PR IL RTE 59 NB	8035+75.75	8035+91.77	42
SUBTOTAL				121
SHARED-USE PATH - 80% FED/20% STATE				
ROADWAY	ALIGNMENT	STATION START	STATION END	AREA (SQ FT)
IL-59	PR IL RTE 59 SB	6991+71.08	6991+76.46	18
IL-59	PR IL RTE 59 SB	6992+10.64	6992+18.36	26
IL-59	PR IL RTE 59 SB	6999+31.24	6999+41.24	25
IL-59	PR IL RTE 59 NB	7999+35.75	7999+45.75	20
IL-59	PR IL RTE 59 NB	7999+35.75	7999+45.75	20
IL-59	PR IL RTE 59 NB	7999+35.75	7999+45.75	20
IL-59	PR IL RTE 59 NB	8009+81.17	8009+83.86	25
IL-59	PR IL RTE 59 NB	8010+29.38	8010+31.38	20
IL-59	PR IL RTE 59 NB	8011+70.88	8011+73.70	28
IL-59	PR IL RTE 59 NB	8021+50.38	8021+53.76	36
IL-59	PR IL RTE 59 NB	8012+20.62	8012+23.53	29
SUBTOTAL				267
GRAND TOTAL				388

MODEL: Default  
 FILE: \\benedsch-pw-bentley.com\benedsch-pw-01\Documents\1107005\10740\_001\Eng\_Docs\_Phase 1\General\1162\115-shi-schedule-21.dgn  
 D:\162H15-shi-schedule-21.dgn  
 50107  
 2012/11/30



USER NAME = nReynolds	DESIGNED -	REVISED -
PLOT SCALE = 24,0000 * / ft.	DRAWN -	REVISED -
PLOT DATE = 2/8/2022	CHECKED -	REVISED -
	DATE - 02/04/2022	REVISED -

**STATE OF ILLINOIS**  
**DEPARTMENT OF TRANSPORTATION**

**SCHEDULE OF QUANTITIES**  
**SHARED-USE PATH**

SCALE: NO SCALE SHEET OF SHEETS STA. TO STA.

F.A./P RTE.	SECTION	COUNTY	TOTAL SHEETS	SHEET NO.
*	2018-075-R	WILL	1510	91
CONTRACT NO. 62H15				
* FAI 55, FAP 338 ILLINOIS FED. AID PROJECT				

CHAIN LINK FENCE, 4'						
ROADWAY URBAN - 90% FED/10% STATE						
ROADWAY	ALIGNMENT	STATION START	OFFSET (LT/RT)	STATION END	OFFSET (LT/RT)	LENGTH (FOOT)
I-55	EX CL I-55	329+49.94	105.58' RT	330+56.53	146.64' RT	111
I-55	EX CL I-55	287+32.22	379.56' RT	301+90.00	92.58' RT	1,445
I-55	EX CL I-55	243+89.38	90.97' RT	260+67.43	382.66' RT	1,867
I-55	EX CL I-56	272+24.00	81.87' LT	279+35.00	101.47' LT	34
I-55	EX CL I-55	326+00.00	117.42' LT	328+09.98	102.54' LT	220
I-55	EX CL I-55	300+81.42	517.87' LT	300+99.45	147.23' LT	741
W FRONTAGE RD	EX CL W FRONTAGE RD	5524+17.04	22.20' RT	5543+97.95	531.01' RT	2,069
SUBTOTAL						6,487
ROADWAY URBAN - 100% JOLIET						
ROADWAY	ALIGNMENT	STATION START	OFFSET (LT/RT)	STATION END	OFFSET (LT/RT)	LENGTH (FOOT)
RAMP B	PR IL 59 RAMP B N	1106+69.48	57.00' RT	1131+90.92	323.79' RT	2,607
SUBTOTAL						2,607
GRAND TOTAL						9,094

TEMPORARY CHAIN LINK FENCE (PORTABLE)							
ROADWAY URBAN - 90% FED/10% STATE							
CONTRACTOR EXCLUSION AREA	ROADWAY	ALIGNMENT	STATION START	OFFSET (LT/RT)	STATION END	OFFSET (LT/RT)	LENGTH (FOOT)
LOCATION 2	FRONTAGE RD	EXWESTFRRD	5533+85.28	125.66 RT	5534+04.86	81.81 RT	134
LOCATION 3	SEIL RD	EXSEILRDCL	4015+62.17	86.17 RT	4016+40.00	100.43 RT	672
LOCATION 4	SEIL RD	EXSEILRDCL	4014+88.81	175.56 LT	4016+79.26	173.97 LT	1,286
SUBTOTAL							2,092
GRAND TOTAL							2,092

CHAIN LINK GATES, 4' X 4' SINGLE						
ROADWAY URBAN - 90% FED/10% STATE						
ROADWAY	ALIGNMENT	STATION START	OFFSET (LT/RT)	STATION END	OFFSET (LT/RT)	EACH
I-55	EX CL I-55	298+03.04	131.65' RT	298+07.04	130.81' RT	1
I-55	EX CL I-55	327+00.92	102.54' LT	327+04.92	102.54' LT	1
I-55	EX CL I-55	329+97.66	117.06' RT	330+01.66	117.88' RT	1
W FRONTAGE RD	EX W CL FRONTAGE RD	5530+00.12	25.18' RT	5530+04.12	25.18' RT	1
SUBTOTAL						4
ROADWAY URBAN - 100% JOLIET						
ROADWAY	ALIGNMENT	STATION START	OFFSET (LT/RT)	STATION END	OFFSET (LT/RT)	EACH
RAMP B	PR IL 59 RAMP B N	1109+84.36	49.73' RT	1109+88.36	49.73' RT	1
RAMP B	PR IL 59 RAMP B N	1117+63.20	53.46' RT	1117+67.20	53.46' RT	1
SUBTOTAL						2
GRAND TOTAL						6

CHAIN LINK GATES, 4' X 16' DOUBLE						
ROADWAY URBAN - 90% FED/10% STATE						
ROADWAY	ALIGNMENT	STATION START	OFFSET (LT/RT)	STATION END	OFFSET (LT/RT)	EACH
I-55	EX CL I-55	243+89.38	90.97' RT	243+89.38	106.97' RT	1
SUBTOTAL						1
ROADWAY URBAN - 100% JOLIET						
ROADWAY	ALIGNMENT	STATION START	OFFSET (LT/RT)	STATION END	OFFSET (LT/RT)	EACH
RAMP B	PR IL 59 RAMP B N	1130+77.63	297.99' RT	1130+93.63	297.99' RT	1
SUBTOTAL						1
GRAND TOTAL						2

MODEL: Default  
 FILE: \\nafe-pw-bentley.com\benesch-pw-01\Documents\10700510740\_001\Eng\_Docs\_Phase 1\General\162H15-shi-schedule-22.dgn  
 D:\62H15-shi-schedule-22.dgn,ign  
 50.107  
 2012/11/30



USER NAME = nReynolds	DESIGNED -	REVISED -
PLOT SCALE = 2,0000' / in.	DRAWN -	REVISED -
PLOT DATE = 3/8/2022	CHECKED -	REVISED -
	DATE - 03/16/2022	REVISED -

**STATE OF ILLINOIS**  
**DEPARTMENT OF TRANSPORTATION**

**SCHEDULE OF QUANTITIES**  
**FENCING**

SCALE: NO SCALE SHEET OF SHEETS STA. TO STA.

F.A./P RTE.	SECTION	COUNTY	TOTAL SHEETS	SHEET NO.
*	2018-075-R	WILL	1510	92
CONTRACT NO. 62H15				
* FAI 55, FAP 338 ILLINOIS FED. AID PROJECT				



ATB-01

MATCH LINE  
SEE BELOW

MATCH LINE  
SEE BELOW

MATCH LINE  
SEE BELOW

MATCH LINE  
SEE BELOW

MATCH LINE  
SEE BELOW

MATCH LINE  
SEE BELOW

MATCH LINE  
SEE BELOW

MATCH LINE  
SEE BELOW

MATCH LINE  
SEE BELOW

MATCH LINE  
SEE BELOW

MATCH LINE  
SEE BELOW

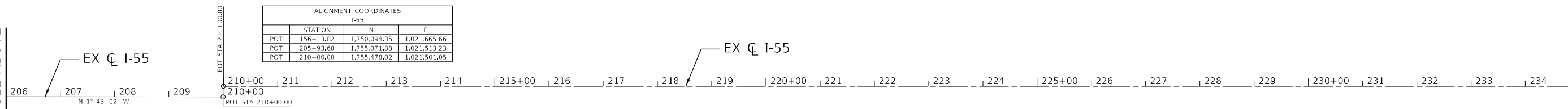
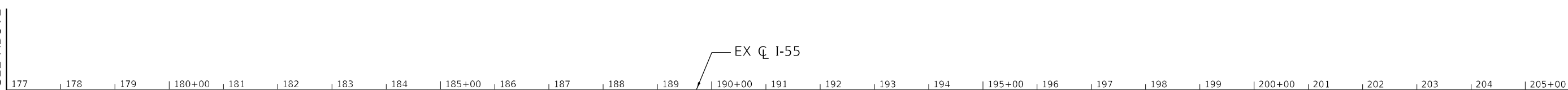
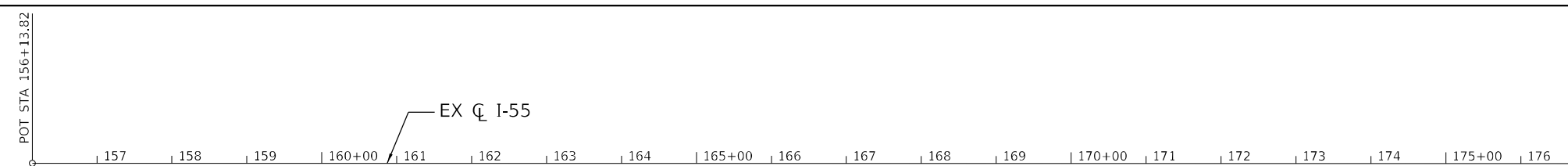

ALIGNMENT COORDINATES I-55			
POT	STATION	N	E
POT	156+13.82	1,750,094.35	1,021,665.66
POT	205+93.68	1,755,071.88	1,021,513.23
POT	210+00.00	1,755,478.02	1,021,501.05

EX W FRONTAGE RD CURVE 1  
 PI STA. = 5501+57.68  
 $\Delta = 1^\circ 06' 02''$  (RT)  
 $D = 0^\circ 20' 56''$   
 $R = 16,415.98'$   
 $T = 157.67'$   
 $L = 315.33'$   
 $E = 0.76'$   
 $e = \_\_\_\_\_\_$   
 $T.R. = \_\_\_\_\_\_$   
 $S.E. RUN = \_\_\_\_\_\_$   
 $P.C. STA. = 5500+00.01$   
 $P.T. STA. = 5503+15.34$

EX W FRONTAGE RD CURVE 2  
 PI STA. = 5519+76.57  
 $\Delta = 36^\circ 08' 17''$  (LT)  
 $D = 5^\circ 04' 57''$   
 $R = 1,127.29'$   
 $T = 367.42'$   
 $L = 710.36'$   
 $E = 58.37'$   
 $e = \_\_\_\_\_\_$   
 $T.R. = \_\_\_\_\_\_$   
 $S.E. RUN = \_\_\_\_\_\_$   
 $P.C. STA. = 5516+09.15$   
 $P.T. STA. = 5523+19.51$

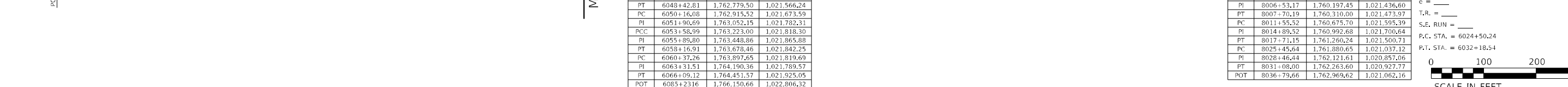
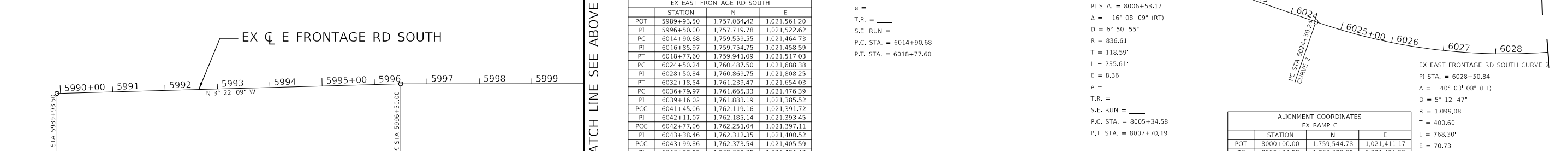
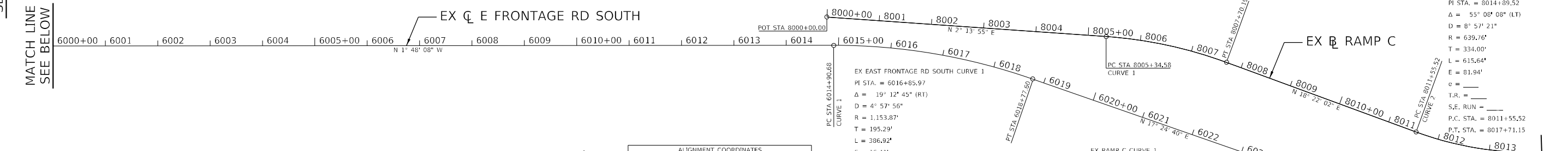
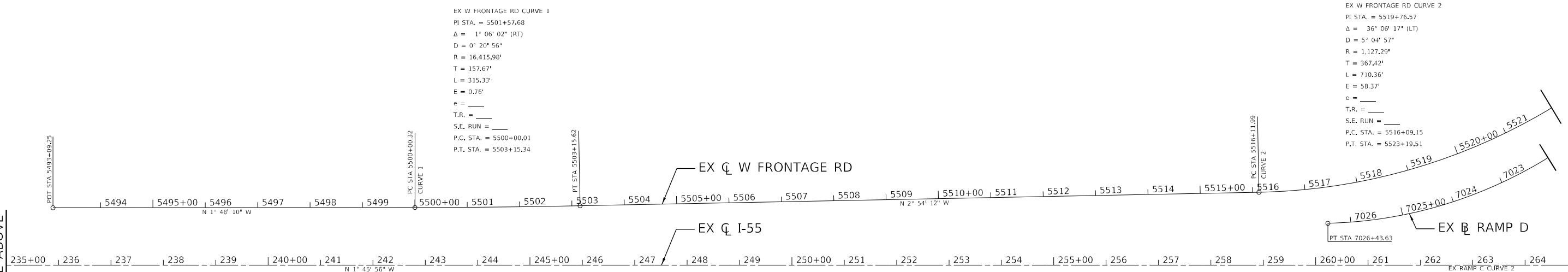

ALIGNMENT COORDINATES EX EAST FRONTAGE RD SOUTH			
POT	STATION	N	E
POT	5989+93.50	1,757,064.42	1,021,561.20
PI	5996+50.00	1,757,719.78	1,021,522.62
PC	6014+90.68	1,759,559.55	1,021,464.73
PI	6016+85.97	1,759,754.75	1,021,458.59
PT	6018+77.60	1,759,941.09	1,021,517.03
PC	6024+50.24	1,760,487.50	1,021,688.38
PI	6028+50.84	1,760,869.75	1,021,808.25
PT	6032+18.54	1,761,239.47	1,021,654.03
PC	6036+79.97	1,761,665.33	1,021,476.39
PI	6039+16.02	1,761,883.19	1,021,385.52
PCC	6041+45.06	1,762,119.16	1,021,391.72
PI	6042+11.07	1,762,185.14	1,021,393.45
PCC	6042+77.06	1,762,251.04	1,021,397.11
PI	6043+38.46	1,762,312.35	1,021,400.52
PCC	6043+99.86	1,762,373.54	1,021,405.59
PI	6046+27.95	1,762,600.85	1,021,424.43
PT	6048+42.81	1,762,779.50	1,021,566.24
PC	6050+16.08	1,762,915.52	1,021,673.59
PI	6051+90.69	1,763,052.15	1,021,782.31
PCC	6053+58.99	1,763,223.00	1,021,818.30
PI	6055+89.80	1,763,448.86	1,021,865.88
PT	6058+16.91	1,763,678.46	1,021,842.25
PC	6060+37.26	1,763,897.65	1,021,819.69
PI	6063+31.51	1,764,190.36	1,021,789.57
PT	6066+09.12	1,764,451.57	1,021,925.05
POT	6085+2316	1,766,150.66	1,022,806.32

EX EAST FRONTAGE RD SOUTH CURVE 1  
 PI STA. = 6016+85.97  
 $\Delta = 19^\circ 12' 45''$  (RT)  
 $D = 4^\circ 57' 56''$   
 $R = 1,153.87'$   
 $T = 195.29'$   
 $L = 386.92'$   
 $E = 16.41'$   
 $e = \_\_\_\_\_\_$   
 $T.R. = \_\_\_\_\_\_$   
 $S.E. RUN = \_\_\_\_\_\_$   
 $P.C. STA. = 6014+90.68$   
 $P.T. STA. = 6018+77.60$

EX RAMP C CURVE 1  
 PI STA. = 8006+53.17  
 $\Delta = 16^\circ 08' 09''$  (RT)  
 $D = 6^\circ 50' 55''$   
 $R = 836.61'$   
 $T = 118.59'$   
 $L = 235.61'$   
 $E = 8.36'$   
 $e = \_\_\_\_\_\_$   
 $T.R. = \_\_\_\_\_\_$   
 $S.E. RUN = \_\_\_\_\_\_$   
 $P.C. STA. = 8005+34.58$   
 $P.T. STA. = 8007+70.19$

ALIGNMENT COORDINATES EX RAMP C			
POT	STATION	N	E
POT	8000+00.00	1,759,544.78	1,021,411.17
PC	8005+34.58	1,760,078.95	1,021,431.99
PI	8006+53.17	1,760,197.45	1,021,436.60
PT	8007+70.19	1,760,310.00	1,021,473.97
PC	8011+55.52	1,760,675.70	1,021,595.39
PI	8014+89.52	1,760,992.68	1,021,700.64
PT	8017+71.15	1,761,260.24	1,021,500.71
PC	8025+45.64	1,761,880.65	1,021,037.12
PI	8028+46.44	1,762,121.61	1,020,857.06
PT	8031+08.00	1,762,263.60	1,020,927.77
POT	8036+79.66	1,762,969.62	1,021,062.16



MODEL: Default  
FILE: Atb01.dwg  
D:\162H15-SH-ATB-01\Documents\162H15-SH-ATB-01.dwg  
Phase: Roadway/Alignment/162H15-SH-ATB-01.dwg



USER NAME = jworthington  
PLOT SCALE = 2400,0000 ' / ft.  
PLOT DATE = 2/1/2022

DESIGNED - TKLUEGEL  
DRAWN - KPEARSON  
CHECKED - POBRIEN  
DATE = 02/04/2022

REVISED -  
REVISED -  
REVISED -  
REVISED -

STATE OF ILLINOIS  
DEPARTMENT OF TRANSPORTATION

ALIGNMENT, TIES, & BENCHMARKS  
EXISTING ROADWAYS

SCALE: SHEET OF SHEETS STA. TO STA.

F.A./P.RTE.	SECTION	COUNTY	TOTAL SHEETS	SHEET NO.
FAI 55, FAP 338	2018-075-R	WILL	1510	93
CONTRACT NO. 62H15				

ILLINOIS FED. AID PROJECT

MATCH LINE SEE SHEET ATB-03

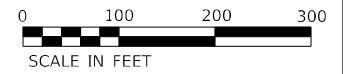

ALIGNMENT COORDINATES EX SEIL RD			
STATION	N	E	
POT 3996+00.00	1,762,950.54	1,018,770.02	
POT 4019+50.00	1,762,970.10	1,021,119.94	

ALIGNMENT COORDINATES EX W FRONTAGE RD			
STATION	N	E	
POT 5493+09.25	1,758,062.84	1,021,292.40	
PC 5500+00.32	1,758,753.57	1,021,270.66	
PI 5501+57.98	1,758,911.15	1,021,265.70	
PT 5503+15.62	1,759,068.60	1,021,257.72	
PC 5516+11.99	1,760,363.30	1,021,192.06	
PI 5519+77.83	1,760,728.68	1,021,173.53	
PT 5523+19.50	1,761,013.54	1,020,943.97	
PC 5530+50.85	1,761,583.00	1,020,485.07	
PI 5534+28.60	1,761,877.13	1,020,248.05	
PT 5537+79.75	1,762,289.11	1,020,236.50	
POT 5544+87.96	1,762,962.59	1,020,214.85	

ALIGNMENT COORDINATES EX RAMP D			
STATION	N	E	
POT 7000+00.00	1,762,969.16	1,021,006.49	
PC 7010+99.92	1,761,900.06	1,020,747.92	
PI 7015+16.69	1,761,494.97	1,020,649.95	
PT 7018+75.23	1,761,168.80	1,020,909.39	
PC 7021+27.68	1,760,971.23	1,021,066.54	
PI 7023+94.16	1,760,762.65	1,021,232.42	
PT 7026+43.63	1,760,496.61	1,021,247.13	

ALIGNMENT COORDINATES EX RAMP C			
STATION	N	E	
POT 7476+95.00	1,762,773.15	1,020,986.89	
PC 7484+55.58	1,763,804.02	1,021,236.18	
PI 7485+80.22	1,763,925.17	1,021,265.48	
PT 7487+03.41	1,764,049.77	1,021,262.03	
PC 7515+20.20	1,766,865.48	1,021,184.07	
PI 7516+58.49	1,767,003.71	1,021,180.25	
PRC 7517+96.74	1,767,141.71	1,021,171.33	
PI 7519+62.51	1,767,307.14	1,021,160.64	
PT 7521+28.25	1,767,472.82	1,021,155.50	
POT 7532+69.29	1,768,613.32	1,021,120.10	

ALIGNMENT COORDINATES EX I-55			
STATION	N	E	
POT 210+00.00	1,755,478.13	1,021,481.43	
PC 273+88.20	1,761,863.29	1,021,284.61	
PI 288+90.08	1,763,364.46	1,021,238.34	
PT 303+26.75	1,764,697.68	1,022,051.87	
PC 384+07.65	1,771,871.11	1,025,650.42	
PI 399+11.93	1,773,206.47	1,026,343.01	
PT 413+49.71	1,774,507.00	1,026,289.72	

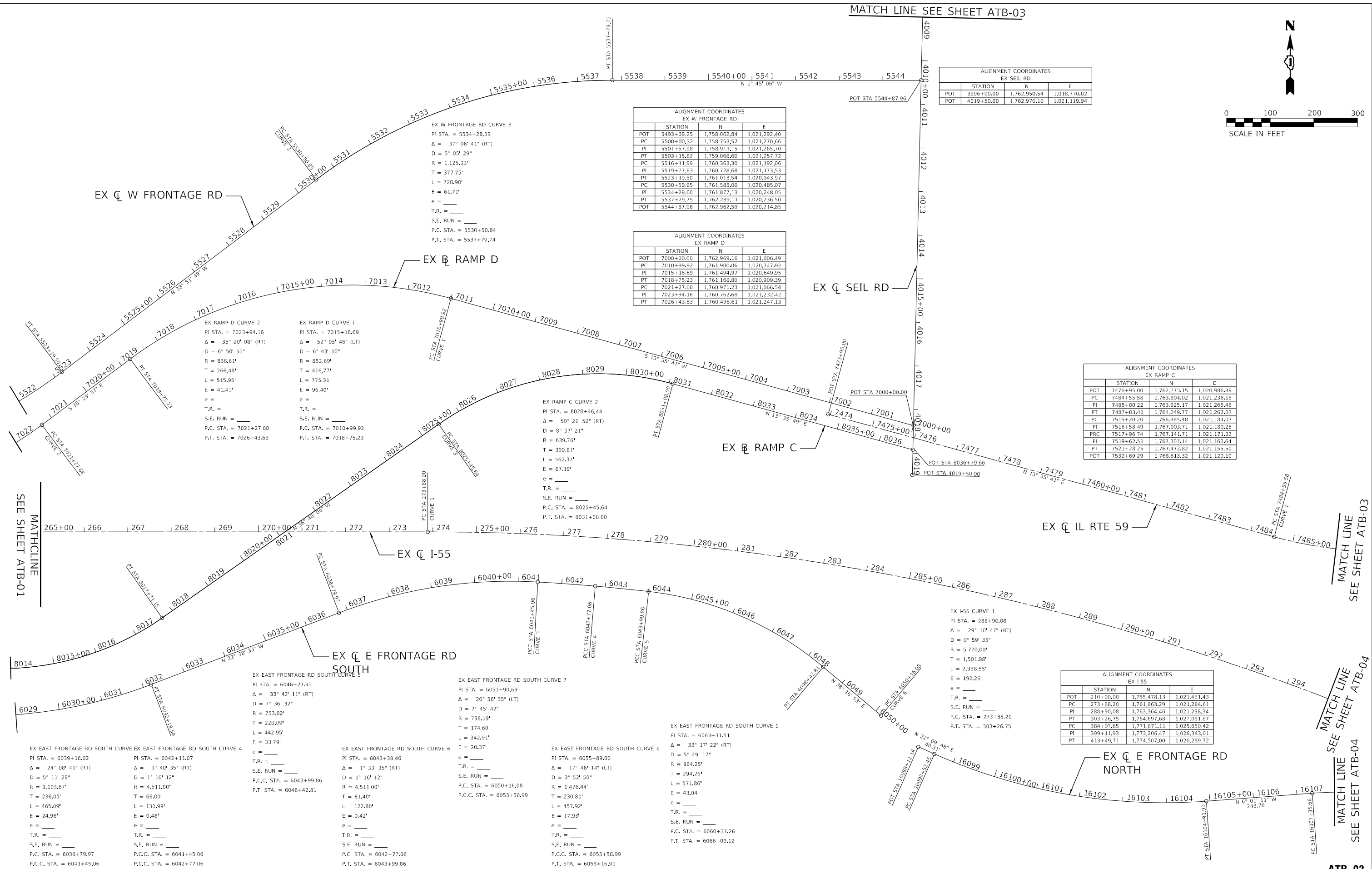

SEE SHEET ATB-01

SEE SHEET ATB-03

SEE SHEET ATB-04

SEE SHEET ATB-04



USER NAME = jworthington	DESIGNED - TKLUEGEL	REVISED -
PLOT SCALE = 2400,0000' / ft.	DRAWN - KPEARSON	REVISED -
PLOT DATE = 2/1/2022	CHECKED - KPEARSON	REVISED -
	DATE - 02/04/2022	REVISED -

**STATE OF ILLINOIS  
DEPARTMENT OF TRANSPORTATION**

ALIGNMENT, TIES, AND BENCHMARKS EXISTING ROADWAYS			
SCALE:	SHEET	OF SHEETS	STA. TO STA.

F.A./P.RTE.	SECTION	COUNTY	TOTAL SHEETS	SHEET NO.
* FAI 55, FAP 338	2018-075-R	WILL	1510	94
CONTRACT NO. 62H15				
ILLINOIS FED. AID PROJECT				

D:\162H15-SH-ATB-02.dgn  
51276  
2012/11/30



EXIST. CURVE EXEFRONTDEXT\_6  
 PI STA. = 16109+91.60 E = 35.68'  
 Δ = 31° 44' 56" (RT) e = \_\_\_\_  
 D = 6° 21' 58" T.R. = \_\_\_\_  
 R = 900.00' S.E. RUN = \_\_\_\_  
 T = 255.94' P.C. STA. = 16107+35.66  
 L = 498.71' P.T. STA. = 16112+34.37

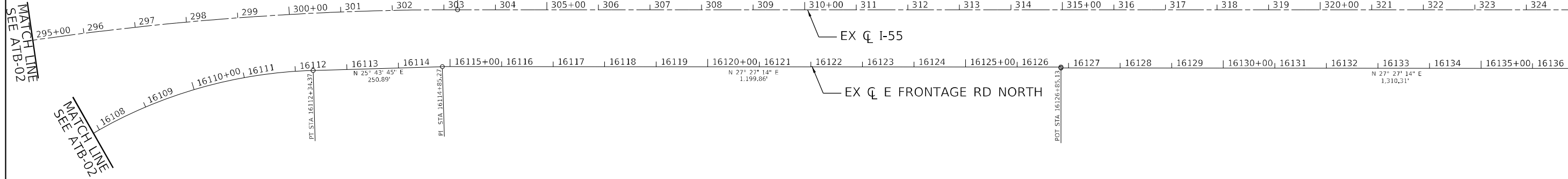

ALIGNMENT COORDINATES PR US RTE 52 RAMP D			
STATION	N	E	
PC	200+00.00	1,767,798.95	1,023,422.53
PI	201+35.92	1,767,667.41	1,023,386.27
PT	202+70.91	1,767,545.52	1,023,328.12
POT	209+61.00	1,766,926.69	1,023,022.70

PROP. US RTE 52 RAMP D CURVE 1  
 PI STA. = 201+35.92  
 Δ = 11° 40' 14" (RT)  
 D = 4° 18' 29"  
 R = 1,330.00'  
 T = 135.92'  
 L = 270.91'  
 E = 6.93'  
 e = 6.0%  
 T.R. = N/A  
 S.E. RUN = 192'  
 P.C. STA. = 200+00.00  
 P.T. STA. = 202+70.91

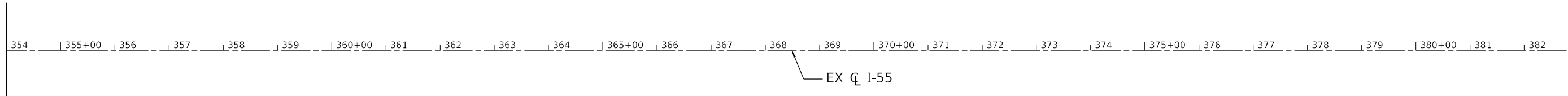
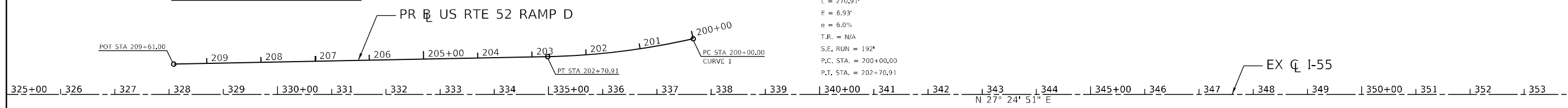

EX I-55 CURVE 1  
 PI STA. = 399+11.93  
 Δ = 29° 26' 39" (LT)  
 D = 1° 00' 03"  
 R = 5,725.00'  
 T = 1,504.28'  
 L = 2,942.06'  
 E = 194.33'  
 e = \_\_\_\_  
 T.R. = \_\_\_\_  
 S.E. RUN = \_\_\_\_  
 P.C. STA. = 384+07.65  
 P.T. STA. = 413+49.71

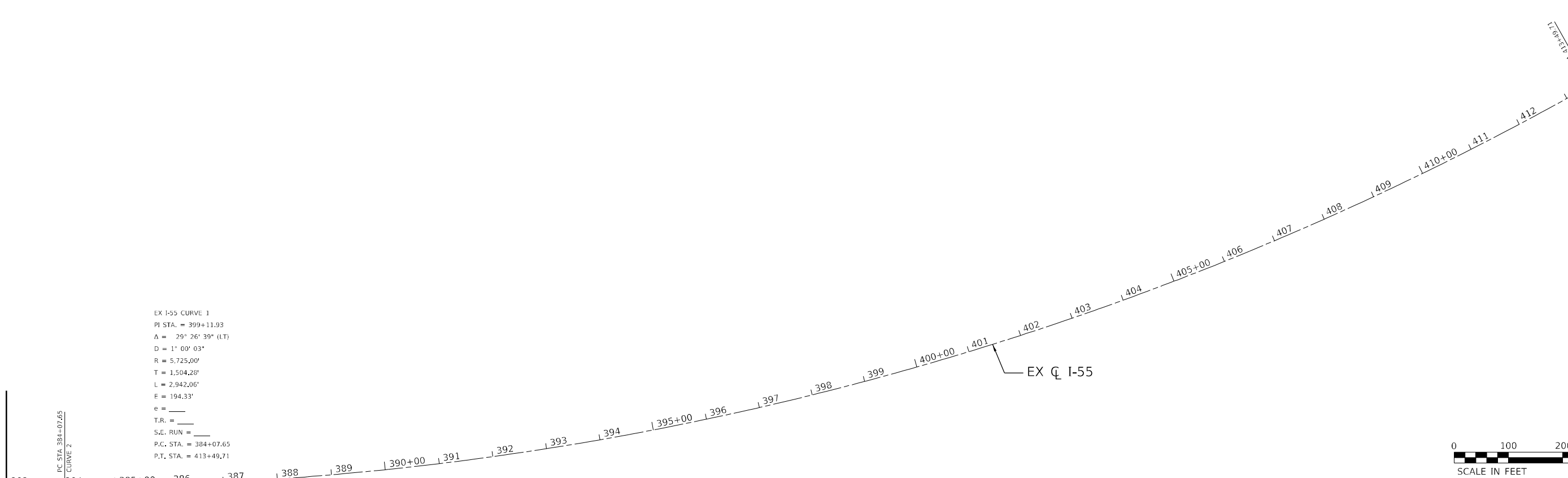

MODEL: Default  
 FILE: \\bmesch-pub\benesch-plot\benesch-plot\Documents\107005\107005\_107040\_000\Eng\_Docs\_Phase\_1\Roadway\Alignment\162H15-fb-ATB-04.dgn



USER NAME = jworthington  
 PLOT SCALE = 2400,0000 ' / ft.  
 PLOT DATE = 2/1/2022

DESIGNED - TKLUEGEL  
 DRAWN - KPEARSON  
 CHECKED - POBRIEN  
 DATE = 02/04/2022

REVISED -  
 REVISED -  
 REVISED -  
 REVISED -

**STATE OF ILLINOIS  
 DEPARTMENT OF TRANSPORTATION**

**ALIGNMENT, TIES, AND BENCHMARKS  
 EXISTING ROADWAYS & PROPOSED US RTE 52 RAMP D**

SCALE: SHEET OF SHEETS STA. TO STA.

F.A./P RTE.	SECTION	COUNTY	TOTAL SHEETS	SHEET NO.
*	2018-075-R	WILL	1510	96
CONTRACT NO. 62H15				
* FAI 55, FAP 338 ILLINOIS FED. AID PROJECT				

**ATB-04**

D:\62H15-SH-ATB-04.dgn  
 51276  
 2012/11/30



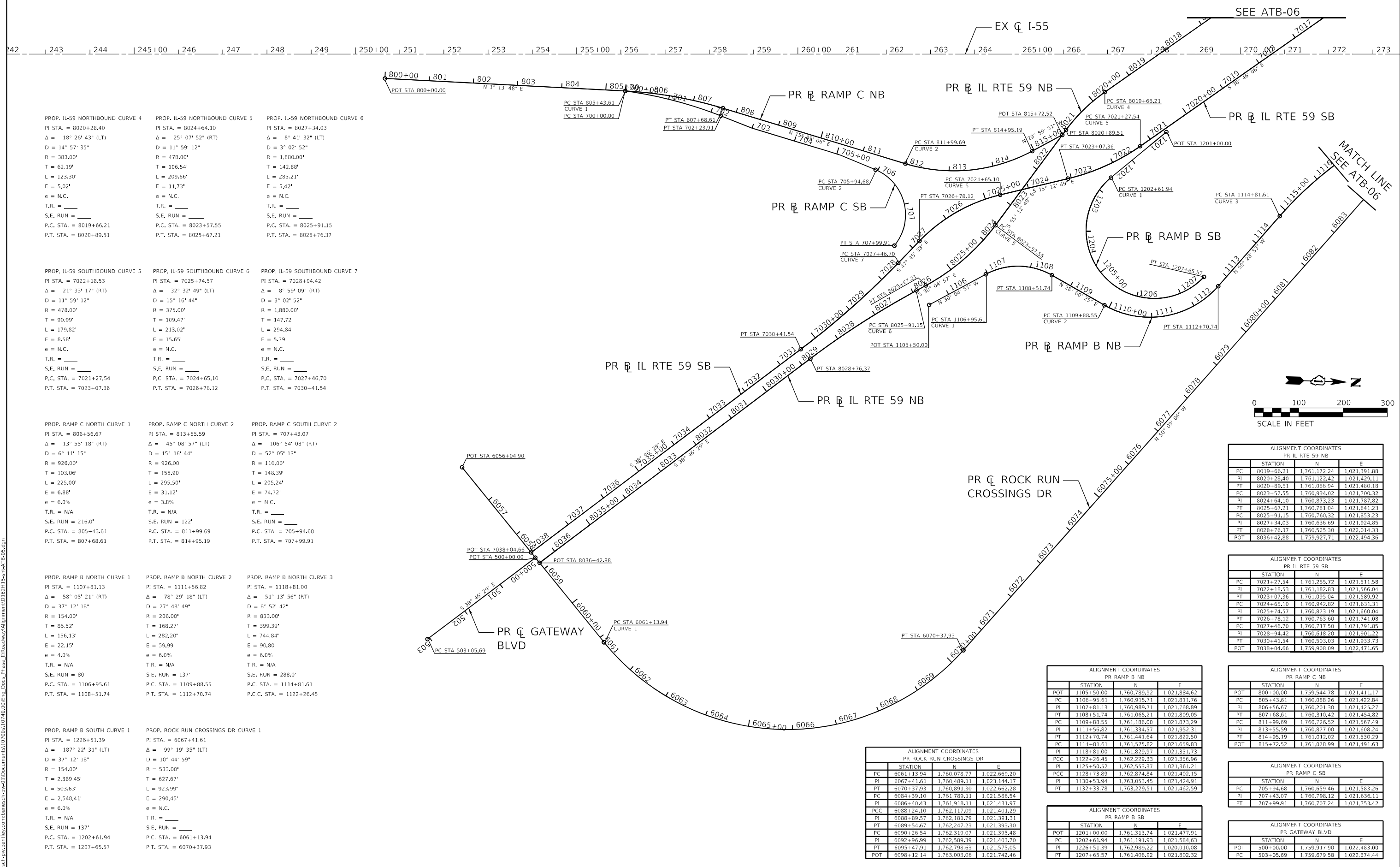

PROP. IL-59 NORTHBOUND CURVE 4 PI STA. = 8020+28.40 Δ = 18° 26' 43" (LT) D = 14° 57' 35" R = 383.00' T = 62.19' L = 123.30' E = 5.02' e = N.C. T.R. = ____ S.E. RUN = ____ P.C. STA. = 8019+66.21 P.T. STA. = 8020+89.51	PROP. IL-59 NORTHBOUND CURVE 5 PI STA. = 8024+64.10 Δ = 25° 07' 52" (RT) D = 11° 59' 12" R = 478.00' T = 106.54' L = 209.66' E = 11.73' e = N.C. T.R. = ____ S.E. RUN = ____ P.C. STA. = 8023+57.55 P.T. STA. = 8025+67.21	PROP. IL-59 NORTHBOUND CURVE 6 PI STA. = 8027+34.03 Δ = 8° 41' 32" (LT) D = 3° 02' 52" R = 1,880.00' T = 142.88' L = 285.21' E = 5.42' e = N.C. T.R. = ____ S.E. RUN = ____ P.C. STA. = 8025+91.15 P.T. STA. = 8028+76.37
--	--	---

PROP. IL-59 SOUTHBOUND CURVE 5 PI STA. = 7022+18.53 Δ = 21° 33' 17" (RT) D = 11° 59' 12" R = 478.00' T = 90.99' L = 179.62' E = 8.58' e = N.C. T.R. = ____ S.E. RUN = ____ P.C. STA. = 7021+27.54 P.T. STA. = 7023+07.36	PROP. IL-59 SOUTHBOUND CURVE 6 PI STA. = 7025+74.57 Δ = 32° 32' 49" (LT) D = 15° 16' 44" R = 375.00' T = 109.47' L = 213.02' E = 15.65' e = N.C. T.R. = ____ S.E. RUN = ____ P.C. STA. = 7024+65.10 P.T. STA. = 7026+78.12	PROP. IL-59 SOUTHBOUND CURVE 7 PI STA. = 7028+94.42 Δ = 8° 59' 09" (RT) D = 3° 02' 52" R = 1,880.00' T = 147.72' L = 294.84' E = 5.79' e = N.C. T.R. = ____ S.E. RUN = ____ P.C. STA. = 7027+46.70 P.T. STA. = 7030+41.54
--	--	---

PROP. RAMP C NORTH CURVE 1 PI STA. = 806+56.67 Δ = 13° 55' 18" (RT) D = 6° 11' 15" R = 926.00' T = 103.06' L = 225.00' E = 6.88' e = 6.0% T.R. = N/A S.E. RUN = 216.0' P.C. STA. = 805+43.61 P.T. STA. = 807+68.61	PROP. RAMP C NORTH CURVE 2 PI STA. = 813+55.59 Δ = 45° 08' 57" (LT) D = 15° 16' 44" R = 926.00' T = 155.90' L = 295.50' E = 31.12' e = 3.8% T.R. = N/A S.E. RUN = 122' P.C. STA. = 811+99.69 P.T. STA. = 814+95.19	PROP. RAMP C SOUTH CURVE 2 PI STA. = 707+43.07 Δ = 106° 54' 08" (RT) D = 52° 05' 13" R = 110.00' T = 148.39' L = 205.24' E = 74.72' e = N.C. T.R. = ____ S.E. RUN = ____ P.C. STA. = 705+94.68 P.T. STA. = 707+99.91
--	--	--

PROP. RAMP B NORTH CURVE 1 PI STA. = 1107+81.13 Δ = 58° 05' 21" (RT) D = 37° 12' 18" R = 154.00' T = 85.52' L = 156.13' E = 22.15' e = 4.0% T.R. = N/A S.E. RUN = 80' P.C. STA. = 1106+95.61 P.T. STA. = 1108+51.74	PROP. RAMP B NORTH CURVE 2 PI STA. = 1111+56.82 Δ = 78° 29' 18" (LT) D = 47° 48' 49" R = 206.00' T = 168.27' L = 282.20' E = 59.99' e = 6.0% T.R. = N/A S.E. RUN = 137' P.C. STA. = 1109+88.55 P.T. STA. = 1112+70.74	PROP. RAMP B NORTH CURVE 3 PI STA. = 1118+81.00 Δ = 51° 13' 56" (RT) D = 6° 52' 42" R = 833.00' T = 399.39' L = 744.84' E = 90.80' e = 6.0% T.R. = N/A S.E. RUN = 288.0' P.C. STA. = 1114+81.61 P.C.C. STA. = 1122+26.45
---	---	--

PROP. RAMP B SOUTH CURVE 1 PI STA. = 1226+51.39 Δ = 187° 22' 31" (LT) D = 37° 12' 18" R = 154.00' T = 2,389.45' L = 503.63' E = 2,548.41' e = 6.0% T.R. = N/A S.E. RUN = 137' P.C. STA. = 1202+61.94 P.T. STA. = 1207+65.57	PROP. ROCK RUN CROSSINGS DR CURVE 1 PI STA. = 6067+41.61 Δ = 99° 19' 35" (LT) D = 10° 44' 59" R = 533.00' T = 627.67' L = 923.99' E = 290.45' e = N.C. T.R. = ____ S.E. RUN = ____ P.C. STA. = 6061+13.94 P.T. STA. = 6070+37.93
---	--

ALIGNMENT COORDINATES PR IL RTE 59 NB		
STATION	N	E
PC 8019+66.21	1,761,172.24	1,021,391.88
PI 8020+28.40	1,761,122.42	1,021,429.11
PT 8020+89.51	1,761,086.94	1,021,480.18
PC 8023+57.55	1,760,934.02	1,021,700.32
PI 8024+64.10	1,760,873.23	1,021,787.82
PT 8025+67.21	1,760,781.04	1,021,841.23
PC 8025+91.15	1,760,760.32	1,021,853.23
PI 8027+34.03	1,760,636.69	1,021,924.85
PT 8028+76.37	1,760,525.30	1,022,014.33
POT 8036+42.88	1,759,927.71	1,022,494.36

ALIGNMENT COORDINATES PR IL RTE 59 SB		
STATION	N	E
PC 7021+27.54	1,761,255.72	1,021,511.58
PI 7022+18.53	1,761,182.83	1,021,566.04
PT 7023+07.36	1,761,095.04	1,021,589.92
PC 7024+65.10	1,760,942.82	1,021,631.31
PI 7025+74.57	1,760,873.19	1,021,660.04
PT 7026+78.12	1,760,763.60	1,021,741.08
PC 7027+46.70	1,760,717.50	1,021,791.85
PI 7028+94.42	1,760,618.20	1,021,901.23
PT 7030+41.54	1,760,503.03	1,021,933.73
POT 7038+04.66	1,759,908.09	1,022,471.65

ALIGNMENT COORDINATES PR RAMP C NB		
STATION	N	E
POT 1105+50.00	1,760,789.92	1,021,884.62
PC 1106+95.61	1,760,915.71	1,021,811.76
PI 1107+81.13	1,760,989.71	1,021,768.89
PT 1108+51.74	1,761,065.21	1,021,809.05
PC 1109+88.55	1,761,186.00	1,021,873.29
PI 1111+56.82	1,761,334.57	1,021,952.31
PT 1112+70.74	1,761,441.64	1,021,822.50
PC 1114+81.61	1,761,575.82	1,021,659.83
PI 1118+81.00	1,761,829.97	1,021,351.73
PCC 1122+26.45	1,762,229.33	1,021,356.96
PI 1125+50.52	1,762,553.37	1,021,361.21
PCC 1128+73.89	1,762,874.84	1,021,402.15
PI 1130+53.94	1,763,053.45	1,021,424.91
PT 1132+33.78	1,763,229.51	1,021,462.39

ALIGNMENT COORDINATES PR RAMP C SB		
STATION	N	E
PC 806+56.67	1,760,201.30	1,021,425.27
PT 807+68.61	1,760,310.42	1,021,454.82
PC 811+99.69	1,760,726.52	1,021,567.49
PI 813+55.59	1,760,877.00	1,021,608.24
PT 814+95.19	1,761,012.02	1,021,530.29
POT 815+72.52	1,761,078.99	1,021,491.63

ALIGNMENT COORDINATES PR RAMP B SB		
STATION	N	E
POT 1201+00.00	1,761,313.74	1,021,477.91
PC 1202+61.94	1,761,191.93	1,021,584.63
PI 1226+51.39	1,762,989.22	1,020,010.08
PT 1207+65.57	1,761,408.92	1,021,802.32

ALIGNMENT COORDINATES PR RAMP B NB		
STATION	N	E
POT 705+94.68	1,760,659.46	1,021,563.26
PI 707+43.07	1,760,798.12	1,021,636.11
PT 707+99.91	1,760,707.24	1,021,753.42

ALIGNMENT COORDINATES PR GATEWAY BLVD		
STATION	N	E
POT 500+00.00	1,759,917.90	1,022,483.00
PC 503+05.69	1,759,679.58	1,022,674.44

ALIGNMENT COORDINATES PR ROCK RUN CROSSINGS DR		
STATION	N	E
PC 6061+13.94	1,760,078.77	1,022,669.20
PI 6067+41.61	1,760,489.11	1,023,144.17
PT 6070+37.93	1,760,891.30	1,022,662.28
PC 6084+39.10	1,761,789.11	1,021,596.54
PI 6086+40.43	1,761,918.11	1,021,431.57
PCC 6088+24.10	1,762,117.09	1,021,401.29
PI 6088+89.57	1,762,181.79	1,021,391.31
PT 6089+54.67	1,762,247.23	1,021,393.30
PC 6090+26.54	1,762,319.07	1,021,395.48
PI 6092+96.99	1,762,589.39	1,021,403.70
PT 6095+47.91	1,762,798.63	1,021,575.05
POT 6098+12.14	1,763,003.06	1,021,742.46

MODEL: D:\default\benesch-ar\benesch-ar\Documents\10740\_00\Eng\_Docs\Roadway\Alignment\10740\_00-ATB-05.dgn  
 FILE: 10740\_00-ATB-05.dwg  
 USER: jworthington  
 DATE: 2/1/2022  
 PLOT SCALE = 2400,0000' / ft.  
 PLOT DATE = 2/1/2022



USER NAME = jworthington	DESIGNED - TKLUEGEL	REVISED -
PLOT SCALE = 2400,0000' / ft.	DRAWN - KPEARSON	REVISED -
PLOT DATE = 2/1/2022	CHECKED - POBRIEN	REVISED -
	DATE = 02/04/2022	REVISED -

**STATE OF ILLINOIS  
DEPARTMENT OF TRANSPORTATION**

**ALIGNMENT, TIES, & BENCHMARKS  
PROPOSED ROADWAYS**

SCALE: SHEET OF SHEETS STA. TO STA.

F.A./P.RTE. =	SECTION = 2018-075-R	COUNTY = WILL	TOTAL SHEETS = 1510	SHEET NO. = 97
CONTRACT NO. 62H15				
ILLINOIS FED. AID PROJECT				

ATB-05

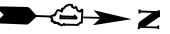

<b>PROP. IL-59 NORTHBOUND CURVE 2</b> PI STA. = 8008+50.38 Δ = 33° 19' 45" (LT) D = 9° 57' 52" R = 575.00' T = 172.12' L = 334.48' E = 25.21' e = 4.0% T.R. = N/A S.E. RUN = 192' P.C. STA. = 8006+78.26 P.T. STA. = 8010+12.74	<b>PROP. IL-59 NORTHBOUND CURVE 3</b> PI STA. = 8013+27.96 Δ = 17° 02' 01" (LT) D = 14° 50' 36" R = 386.00' T = 57.80' L = 114.76' E = 4.30' e = N.C. T.R. = ____ S.E. RUN = ____ P.C. STA. = 8012+70.15 P.T. STA. = 8013+84.91	<b>PROP. IL-59 SOUTHBOUND CURVE 1</b> PI STA. = 6990+17.17 Δ = 15° 10' 50" (RT) D = 6° 10' 42" R = 927.38' T = 123.58' L = 245.71' E = 8.20' e = MATCH EX. T.R. = N/A S.E. RUN = N/A P.C. STA. = 6988+93.60 P.T. STA. = 6991+39.30	<b>PROP. IL-59 SOUTHBOUND CURVE 2</b> PI STA. = 7002+00.00 Δ = 16° 37' 12" (RT) D = 10° 04' 10" R = 569.00' T = 83.11' L = 165.05' E = 6.04' e = 3.4% T.R. = N/A S.E. RUN = 124' P.C. STA. = 7001+16.89 P.T. STA. = 7002+81.94	<b>PROP. IL-59 SOUTHBOUND CURVE 3</b> PI STA. = 7010+33.87 Δ = 94° 56' 57" (LT) D = 16° 22' 13" R = 350.00' T = 381.62' L = 580.01' E = 16.781' e = 3.8% T.R. = N/A S.E. RUN = 122' P.C. STA. = 7006+52.25 P.T. STA. = 7012+32.26	<b>PROP. IL-59 SOUTHBOUND CURVE 4</b> PI STA. = 7014+59.99 Δ = 27° 57' 59" (RT) D = 16° 22' 13" R = 350.00' T = 87.16' L = 170.84' E = 10.69' e = N.C. T.R. = ____ S.E. RUN = ____ P.C. STA. = 7013+72.84 P.T. STA. = 7015+43.67	<b>PROP. RAMP A NORTH CURVE 1</b> PI STA. = 1014+80.52 Δ = 90° 00' 00" (RT) D = 47° 44' 47" R = 120.00' T = 120.00' L = 188.50' E = 49.71' e = N.C. T.R. = ____ S.E. RUN = ____ P.C. STA. = 1013+60.52 P.T. STA. = 1015+49.02	<b>PROP. RAMP A NORTH CURVE 2</b> PI STA. = 1015+99.62 Δ = 69° 37' 21" (RT) D = 229° 10' 59" R = 17.38' T = 17.38' L = 30.38' E = 5.45' e = N.C. T.R. = ____ S.E. RUN = ____ P.C. STA. = 1015+82.23 P.T. STA. = 1016+12.61	<b>PROP. RAMP A SOUTH CURVE 1</b> PI STA. = 901+93.23 Δ = 3° 03' 09" (LT) D = 1° 15' 17" R = 4,566.00' T = 121.65' L = 243.25' E = 49.71' e = 3.4% T.R. = N/A S.E. RUN = 121' P.C. STA. = 900+71.57 P.T. STA. = 903+14.82	<b>PROP. RAMP A SOUTH CURVE 2</b> PI STA. = 908+65.31 Δ = 9° 28' 15" (LT) D = 6° 44' 55" R = 849.00' T = 70.33' L = 140.34' E = 2.91' e = 6.0% T.R. = N/A S.E. RUN = 192' P.C. STA. = 907+94.98 P.T. STA. = 909+35.32	<b>PROP. RAMP A SOUTH CURVE 3</b> PI STA. = 916+59.22 Δ = 19° 43' 48" (LT) D = 20° 36' 36" R = 278.00' T = 48.34' L = 95.73' E = 4.17' e = N.C. T.R. = ____ S.E. RUN = ____ P.C. STA. = 916+10.88 P.T. STA. = 917+06.61
---	---	--	--	---	--	---	--	---	---	---

<b>PROP. RAMP B NORTH CURVE 4</b> PI STA. = 1125+50.52 Δ = 6° 30' 29" (RT) D = 1° 00' 19" R = 5,700.00' T = 324.07' L = 647.09' E = 9.20' e = 3.4% T.R. = N/A S.E. RUN = 182' P.C.C. STA. = 1122+26.45 P.C.C. STA. = 1128+73.89	<b>PROP. RAMP B NORTH CURVE 5</b> PI STA. = 1130+53.94 Δ = 4° 49' 24" (RT) D = 1° 20' 25" R = 4,275.00' T = 180.05' L = 359.89' E = 3.79' e = 3.4% T.R. = ____ S.E. RUN = ____ P.C.C. STA. = 1128+73.89 P.T. STA. = 1132+33.78	<b>PROP. RAMP D NORTH CURVE 1</b> PI STA. = 1132+22.09 Δ = 0° 14' 16" (RT) D = 1° 00' 10" R = 5,714.00' T = 11.86' L = 23.72' E = 0.01' e = 3.4% T.R. = ____ S.E. RUN = ____ P.C.C. STA. = 1132+10.23 P.T. STA. = 1132+33.95	<b>PROP. RAMP D NORTH CURVE 2</b> PI STA. = 159° 27' 57" (LT) Δ = 34° 06' 17" D = 5,714.00' R = 927.47' T = 927.47' L = 467.58' E = 774.56' e = 6.0% T.R. = N/A S.E. RUN = 137' P.C. STA. = 604+64.66 P.C.C. STA. = 609+32.23	<b>PROP. RAMP D NORTH CURVE 3</b> PI STA. = 609+98.84 Δ = 20° 21' 21" (LT) D = 15° 26' 37" R = 371.00' T = 66.61' L = 131.81' E = 5.93' e = 6.0% T.R. = N/A S.E. RUN = 218' P.C.C. STA. = 609+32.23 P.T. STA. = 610+64.04	<b>PROP. RAMP D SOUTH CURVE 1</b> PI STA. = 410+21.73 Δ = 70° 37' 23" (LT) D = 10° 26' 11" R = 549.00' T = 388.88' L = 676.70' E = 123.78' e = 6.0% T.R. = N/A S.E. RUN = 165' P.C. STA. = 406+32.85 P.T. STA. = 413+09.55	<b>PROP. ROCK RUN CROSSINGS DR CURVE 2</b> PI STA. = 6086+40.43 Δ = 41° 23' 11" (RT) D = 10° 44' 59" R = 533.00' T = 201.33' L = 385.00' E = 36.76' e = N.C. T.R. = ____ S.E. RUN = ____ P.C. STA. = 6084+39.10 P.C.C. STA. = 6088+24.10	<b>PROP. ROCK RUN CROSSINGS DR CURVE 3</b> PI STA. = 6088+89.57 Δ = 10° 30' 21" (RT) D = 8° 02' 46" R = 712.08' T = 65.47' L = 130.57' E = 3.00' e = N.C. T.R. = ____ S.E. RUN = ____ P.C.C. STA. = 6088+24.10 P.T. STA. = 6089+54.67	<b>PROP. ROCK RUN CROSSINGS DR CURVE 4</b> PI STA. = 6092+96.99 Δ = 37° 34' 30" (RT) D = 7° 12' 25" R = 795.00' T = 270.45' L = 521.37' E = 44.74' e = N.C. T.R. = ____ S.E. RUN = ____ P.C. STA. = 6090+26.54 P.T. STA. = 6095+47.91
---	--	--	---	---	--	--	---	---

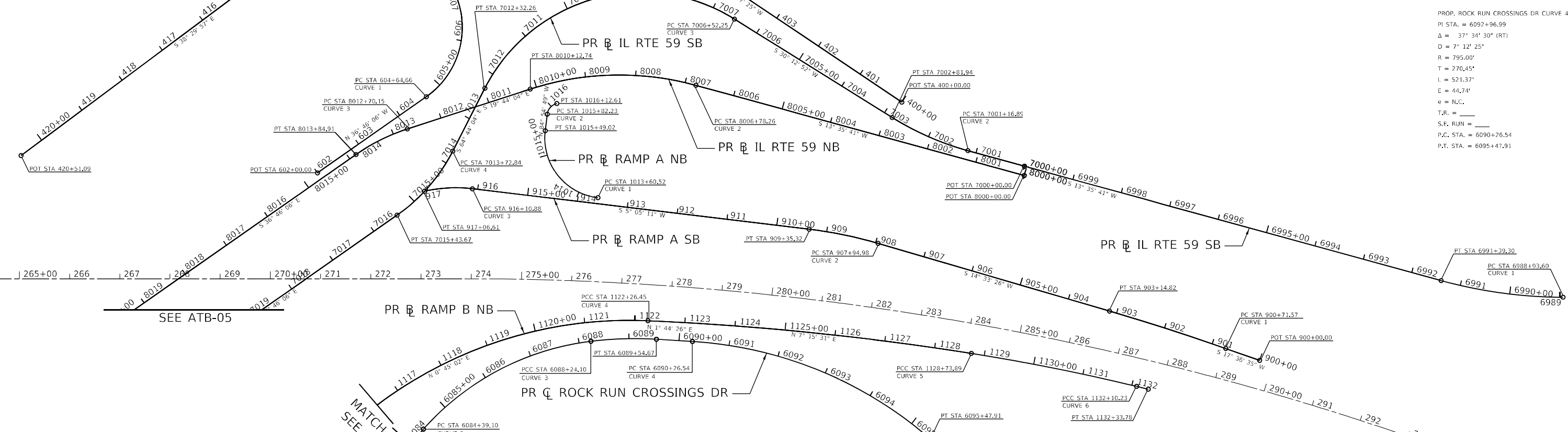

ALIGNMENT COORDINATES PR IL RTE 59 SB			
STATION	N	E	
PC 6988+93.60	1,764,049.55	1,021,251.03	
PT 6990+17.17	1,763,926.07	1,021,257.45	
POT 6991+39.30	1,763,805.90	1,021,278.40	
POT 7000+00.00	1,762,969.32	1,021,076.10	
PC 7001+16.89	1,762,855.70	1,020,998.62	
PI 7002+00.00	1,762,774.92	1,020,979.09	
PT 7002+81.94	1,762,703.10	1,020,937.26	
PC 7006+52.25	1,762,383.10	1,020,750.91	
PI 7010+33.87	1,762,053.33	1,020,558.86	
PT 7012+32.26	1,761,890.45	1,020,903.97	
PC 7013+72.84	1,761,830.45	1,021,031.10	
PI 7014+59.99	1,761,793.25	1,021,109.92	
PT 7015+43.67	1,761,723.43	1,021,167.09	

ALIGNMENT COORDINATES PR RAMP A NB			
STATION	N	E	
PC 1013+60.52	1,762,122.13	1,021,115.14	
PI 1014+80.52	1,762,002.60	1,021,104.50	
PT 1015+49.02	1,762,013.24	1,020,984.97	
PC 1015+82.23	1,762,016.19	1,020,951.89	
PI 1015+99.62	1,762,017.73	1,020,934.57	
PT 1016+12.61	1,762,034.50	1,020,929.99	

ALIGNMENT COORDINATES PR RAMP A SB			
STATION	N	E	
POT 900+00.00	1,763,449.39	1,021,398.42	
PC 900+71.57	1,763,381.17	1,021,376.77	
PI 901+93.23	1,763,265.21	1,021,339.97	
PT 903+14.82	1,763,147.47	1,021,305.39	
PC 907+94.98	1,762,822.72	1,021,186.70	
PI 908+65.31	1,762,814.65	1,021,171.03	
PT 909+35.32	1,762,544.60	1,021,164.79	
PC 916+10.88	1,761,871.70	1,021,104.90	
PI 916+59.22	1,761,823.54	1,021,100.61	
PT 917+06.61	1,761,766.77	1,021,122.83	

ALIGNMENT COORDINATES PR RAMP D NB			
STATION	N	E	
POT 602+00.00	1,761,562.39	1,021,082.88	
PC 604+64.66	1,761,774.30	1,020,924.46	
PI 613+92.12	1,762,517.35	1,020,369.30	
PCC 609+32.23	1,761,626.86	1,020,628.58	
PI 609+98.84	1,761,562.91	1,020,647.20	
PT 610+64.04	1,761,509.43	1,020,686.90	

ALIGNMENT COORDINATES PR RAMP D SB			
STATION	N	E	
POT 400+00.00	1,762,721.22	1,020,906.15	
PC 406+32.85	1,762,185.26	1,020,569.64	
PI 410+21.73	1,761,855.91	1,020,362.85	
PCC 413+09.55	1,761,551.57	1,020,604.93	
POT 420+51.09	1,760,971.23	1,021,066.54	



ATB-06



USER NAME = jwashington
PLOT SCALE = 2400,0000' / ft.
PLOT DATE = 2/1/2022

DESIGNED - TKLUEGEL	REVISED -
DRAWN - KPEARSON	REVISED -
CHECKED - POBRIEN	REVISED -
DATE = 02/04/2022	REVISED -

**STATE OF ILLINOIS  
DEPARTMENT OF TRANSPORTATION**

ALIGNMENT, TIES, & BENCHMARKS PROPOSED ROADWAYS			
F.A./P.RTE.	SECTION	COUNTY	TOTAL SHEETS
*	2018-075-R	WILL	1510 98
CONTRACT NO. 62H15			
SCALE:		SHEET OF SHEETS STA. TO STA.	
F.A.I.P. 55, FAP 338		ILLINOIS FED. AID PROJECT	

**BENCHMARKS**

SITE BENCHMARK #515  
ELEVATION=582.144  
SET CUT SQUARE ON THE E. SIDE OF CONC. LIGHT POLE BASE, W. SIDE OF I-55

SITE BENCHMARK #511  
ELEVATION=579.988  
SET CUT SQUARE NOTCH IN E. CURB LINE OF E. FRONTAGE ROAD 230' N. OF TIMBER RIDGE COURT (ACROSS FROM A LIGHT POLE)

SITE BENCHMARK #402  
ELEVATION=596.016  
SET CUT SQUARE ON TOP OF CONC. HEADWALL @ THE NE COR. OF SE FRONTAGE ROAD & COUNTY FARM ROAD

SITE BENCHMARK #410  
ELEVATION=590.321  
SET CUT SQUARE ON TOP CENTER OF 12" RCP W/FES ON S. SIDE OF SEIL ROAD @ W. SIDE OF EAST ENTRANCE TO "THE BODY WORKS"

SITE BENCHMARK #406  
ELEVATION=608.884  
SET CUT SQUARE ON TOP OF CURB ON THE E'LY SIDE OF CONC. MEDIAN ON IL-59 RAMP FROM NORTHBOUND I-55

**BENCHMARKS CONTINUED**

SITE BENCHMARK #411  
ELEVATION=593.821  
SET CUT SQUARE ON TOP CENTER OF 12" RCP W/FES ON E. SIDE OF SW FRONTAGE ROAD

SITE BENCHMARK #302  
ELEVATION=625.225  
SET 2" DIAMETER ALUMINUM DISC IN BRIDGEWALL @ NW'LY COR. OF NORTHBOUND IL-59 RAMP BRIDGE OVER I-55

SITE BENCHMARK #308  
ELEVATION=623.867  
SET 2" DIAMETER ALUMINUM DISC IN TOP OF CONC. BRIDGEWALL @ NE'LY COR. OF NORTHBOUND IL-59 RAMP OVER I-55

SITE BENCHMARK #306  
ELEVATION=586.251  
SET 2" DIAMETER ALUMINUM DISC IN CONC. CAMERA POLE BASE, EAST SIDE OF I-55, NORTH OF I-80 AND SOUTH OF I-80 ON RAMP TO I-55 NORTHBOUND

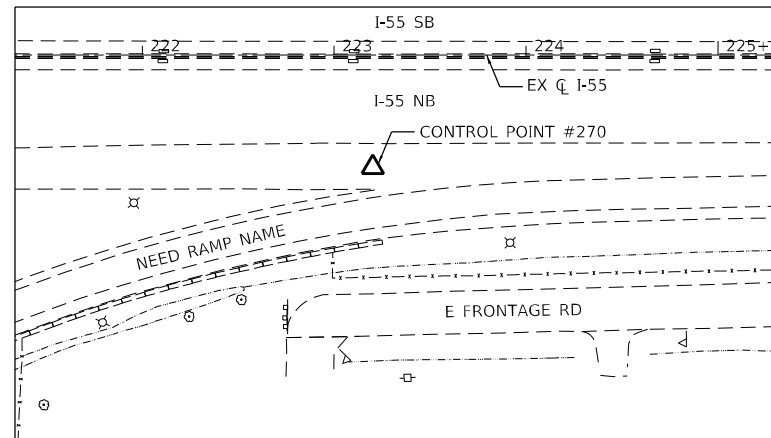

**CONTROL POINT #270**

SET MAG NAIL  
N: 1,756,799.386  
E: 1,021,499.153  
ELEV.=589.984

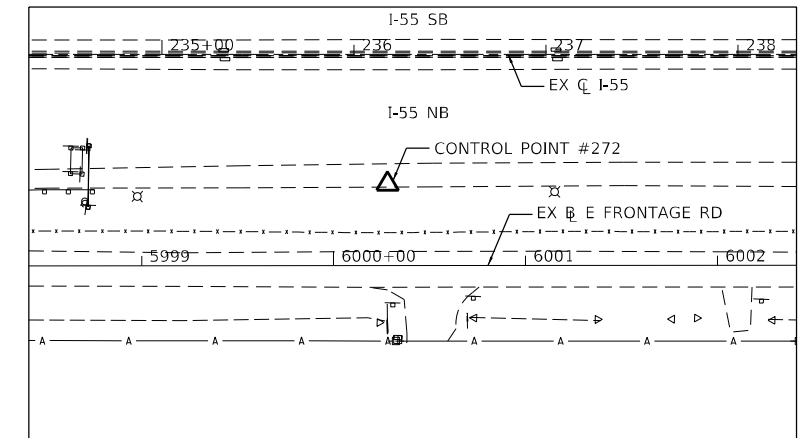

**CONTROL POINT #272**

SET MAG NAIL  
N: 1,758,096.345  
E: 1,021,468.944  
ELEV.=590.261

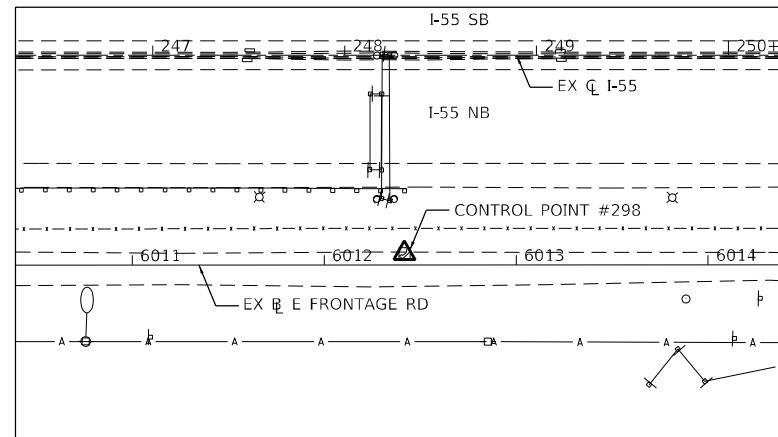
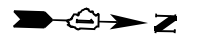

**CONTROL POINT #298**

SET BOAT SPIKE  
N: 1,759,310.553  
E: 1,021,466.512  
ELEV.=592.234

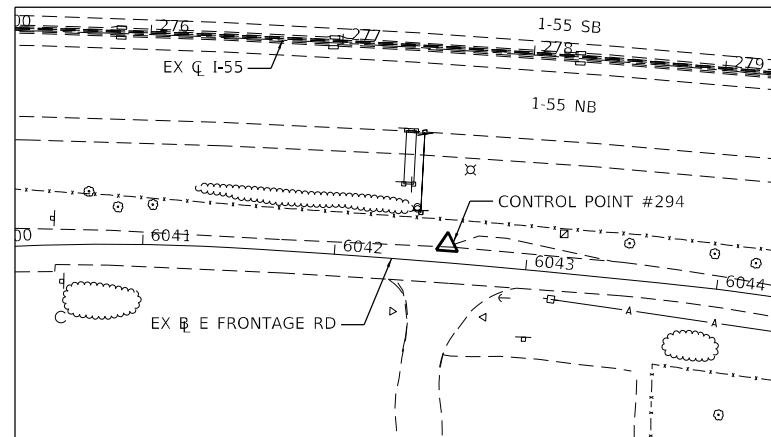

**CONTROL POINT #294**

SET BOAT SPIKE  
N: 1,762,232.718  
E: 1,021,386.622  
ELEV.=596.592

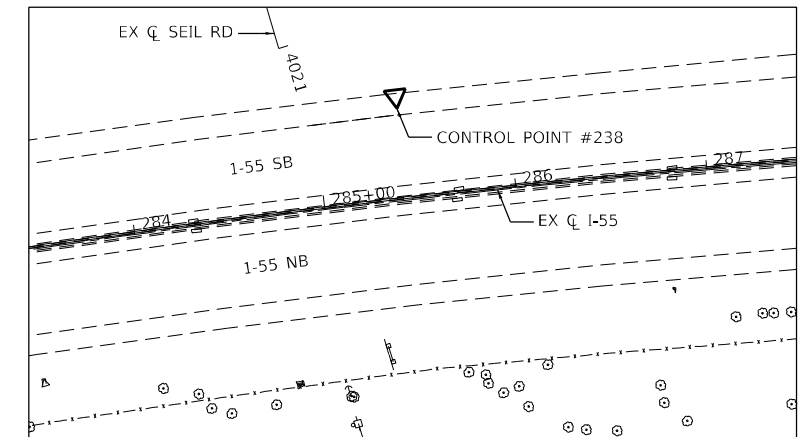

**CONTROL POINT #238**

SET MAG NAIL  
N: 1,763,022.732  
E: 1,021,310.252  
ELEV.=596.704

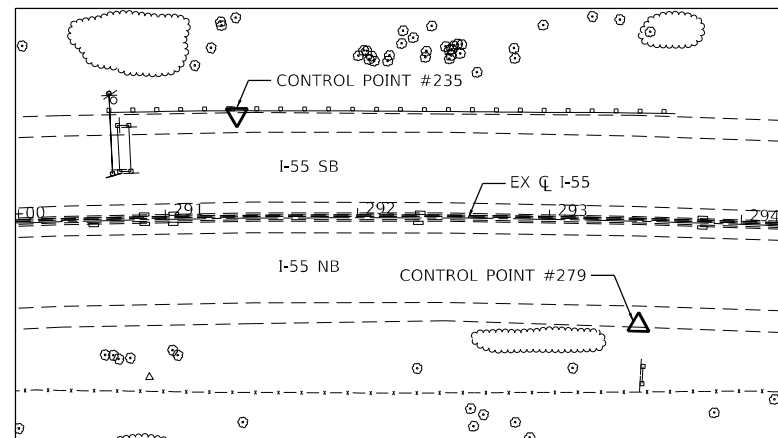

**CONTROL POINT #235 CONTROL POINT #279**

SET MAG NAIL  
N: 1,763,607.899  
E: 1,021,442.540  
ELEV.=597.131

SET MAG NAIL  
N: 1,763,778.223  
E: 1,021,606.301  
ELEV.=596.625

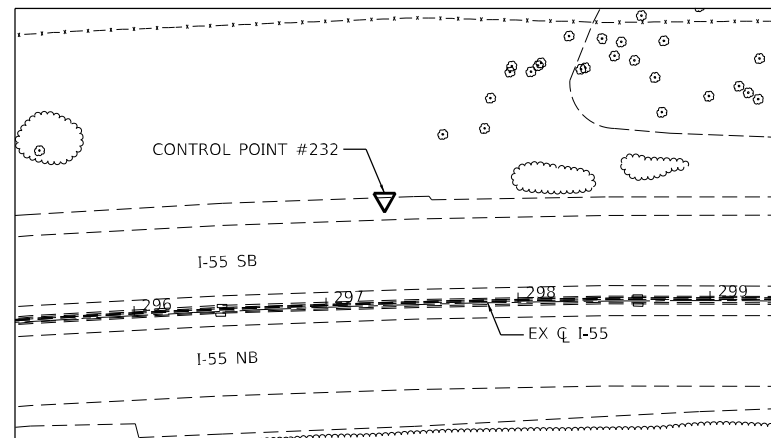

**CONTROL POINT #232**

SET MAG NAIL  
N: 1,764,176.817  
E: 1,021,632.261  
ELEV.=597.382

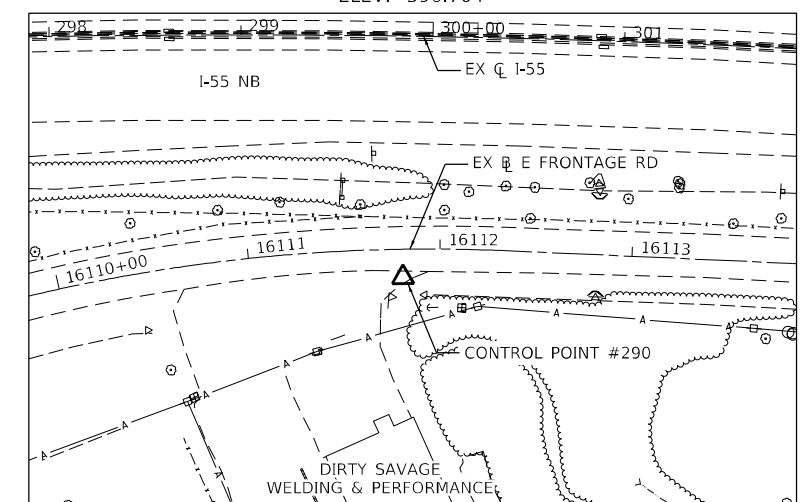
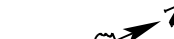

**CONTROL POINT #290**

SET BOAT SPIKE  
N: 1,764,339.789  
E: 1,021,896.010  
ELEV.=597.853



MODEL: Default; FILE: M:\MFC\_Plan\benesch-plan\benesch-plan\107005\107005.dwg; Phase: Roadway; Alignment: D:\BEN15-FBI-ATB-07.dgn



USER NAME = jworthington	DESIGNED - TKLUEGEL	REVISED -
PLOT SCALE = 1200,0000 ' / ft.	DRAWN - JWORTHINGTON	REVISED -
PLOT DATE = 2/1/2022	CHECKED - POBRIEN	REVISED -
	DATE = 02/04/2022	REVISED -

**STATE OF ILLINOIS  
DEPARTMENT OF TRANSPORTATION**

**ALIGNMENT, TIES, & BENCHMARKS**

SCALE: SHEET OF SHEETS STA. TO STA.

F.A./P. RTE.	SECTION	COUNTY	TOTAL SHEETS	SHEET NO.
=	2018-075-R	WILL	1510	99
CONTRACT NO. 62H15				
* FAI 55, FAP 338 ILLINOIS FED. AID PROJECT				

D:\62H15-SH-ATB-07.dgn  
5/12/26  
2012/11/30

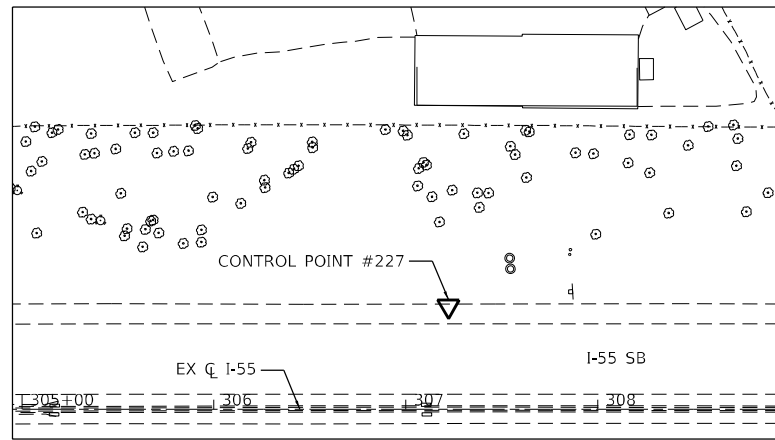

**CONTROL POINT #227**

SET MAG NAIL  
 N: 1,765,073.382  
 E: 1,022,064.230  
 ELEV.=600,293

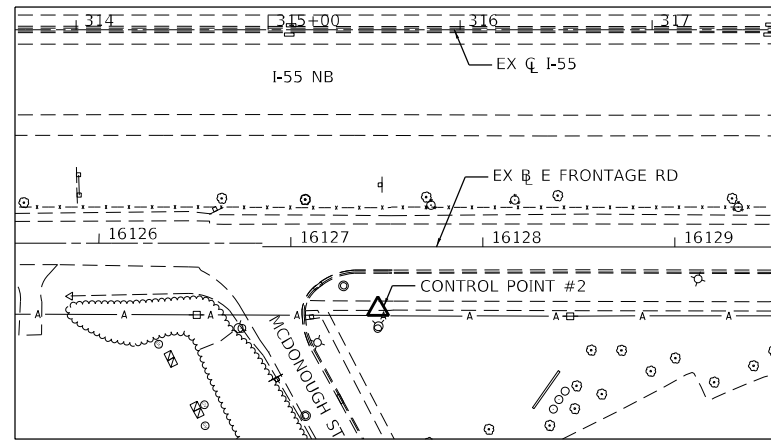
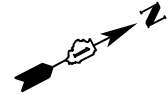

**CONTROL POINT #2**

SET CUT CROSS  
 N: 1,765,722.985  
 E: 1,022,625.558  
 ELEV.=601,920

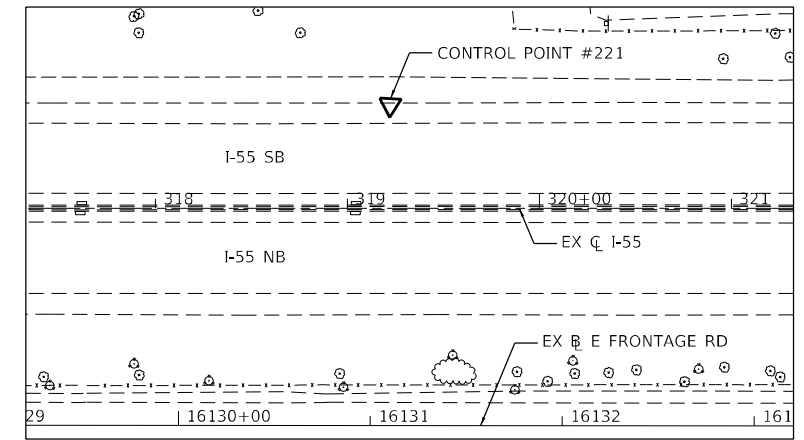

**CONTROL POINT #221**

SET MAG NAIL  
 N: 1,766,138.853  
 E: 1,022,616.604  
 ELEV.=599,887

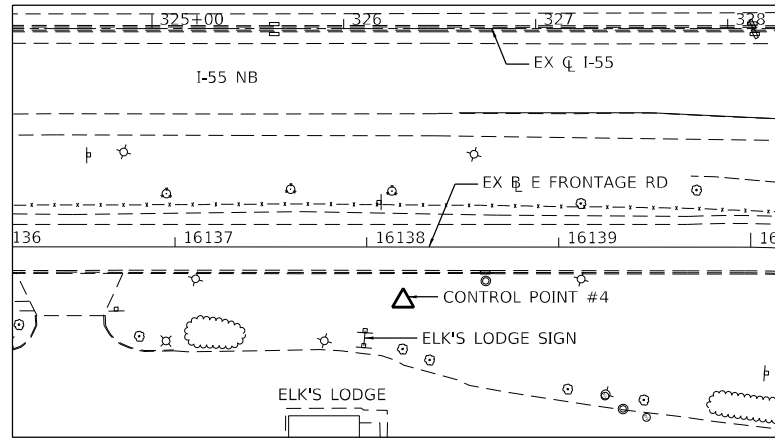
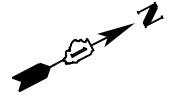

**CONTROL POINT #4**

SET 5/8" REBAR W/CAP  
 N: 1,766,677.760  
 E: 1,023,116.693  
 ELEV.=597,000

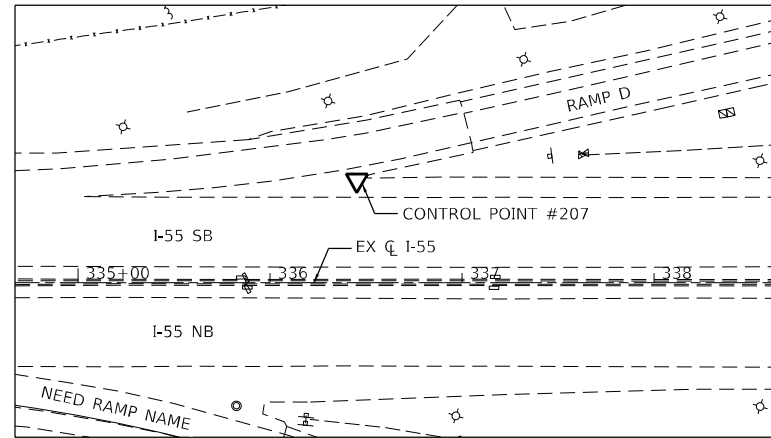
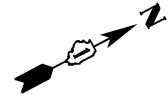

**CONTROL POINT #207**

SET MAG NAIL  
 N: 1,767,668.199  
 E: 1,023,410.339  
 ELEV.=582,604

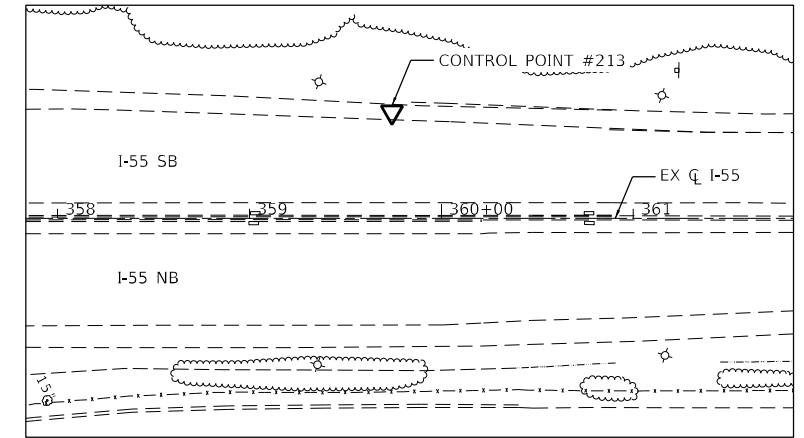
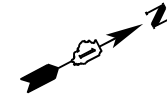

**CONTROL POINT #213**

SET MAG NAIL  
 N: 1,769,736.462  
 E: 1,024,480.878  
 ELEV.=579,861

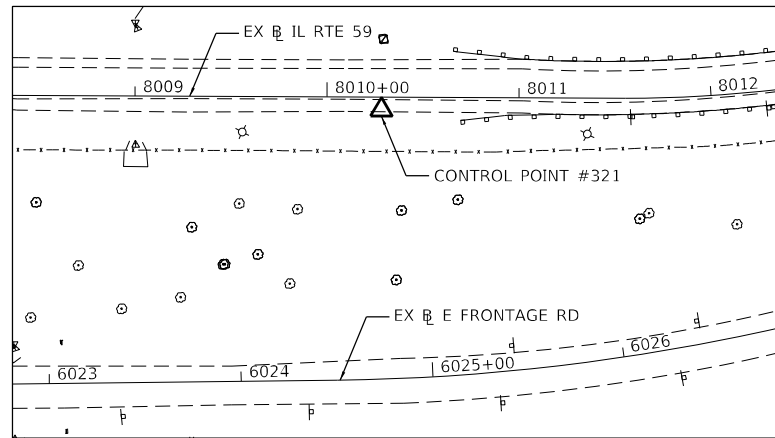
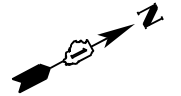

**CONTROL POINT #321**

SET MAG NAIL  
 N: 1,760,552.926  
 E: 1,021,561.628  
 ELEV.=591,725

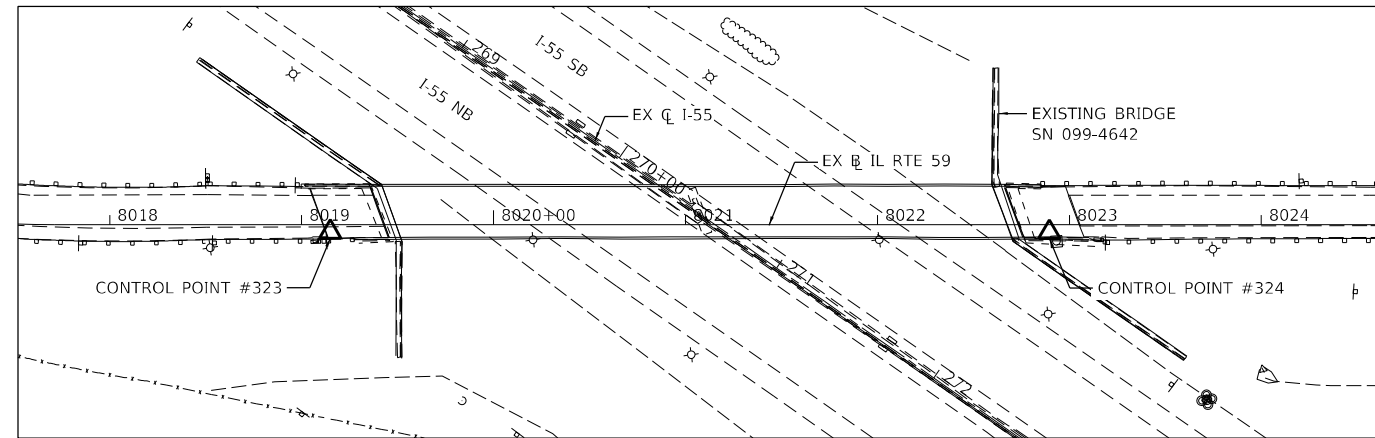

**CONTROL POINT #323**

SET CUT CROSS  
 N: 1,761,377.724  
 E: 1,021,417.809  
 ELEV.=620,595

**CONTROL POINT #324**

SET CUT CROSS  
 N: 1,761,678.009  
 E: 1,021,193.619  
 ELEV.=622,685

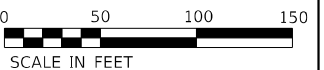
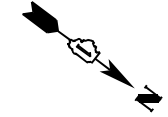

MODEL: Default  
 FILE: \\nautilus.pw.benesch.com\benesch\p01\Documents\107005\107040\_00\Eng\_Docs\_Phase 1\Roadway\Alignment\162H15-FB-ATB-08.dgn  
 2012/11/30



USER NAME = jworthington	DESIGNED - TKLUEGEL	REVISED -
PLOT SCALE = 1200,0000 ' / ft.	DRAWN - JWORTHINGTON	REVISED -
PLOT DATE = 2/1/2022	CHECKED - POBRIEN	REVISED -
	DATE - 02/04/2022	REVISED -

**STATE OF ILLINOIS  
 DEPARTMENT OF TRANSPORTATION**

**ALIGNMENT, TIES, & BENCHMARKS**

SCALE:	SHEET	OF	SHEETS	STA.	TO	STA.
--------	-------	----	--------	------	----	------

F.A./P RTE.	SECTION	COUNTY	TOTAL SHEETS	SHEET NO.
=	2018-075-R	WILL	1510	100
CONTRACT NO. 62H15				
F. 51, 52, 53, 54, 55, 56, 57, 58, 59, 60, 61, 62, 63, 64, 65, 66, 67, 68, 69, 70, 71, 72, 73, 74, 75, 76, 77, 78, 79, 80, 81, 82, 83, 84, 85, 86, 87, 88, 89, 90, 91, 92, 93, 94, 95, 96, 97, 98, 99, 100				