

STATE OF ILLINOIS
DEPARTMENT OF TRANSPORTATION
DIVISION OF HIGHWAYS
**PLANS FOR PROPOSED
FEDERAL AID HIGHWAY**

F. A. ID. PTE.	SECTION	COUNTY	TOTAL SHEETS	SHEET NO.
	14-00032-00-SW	GRUNDY	11	1
STA.		TO STA.		
FED. ROAD DIST. NO.	ILLINOIS	FED. AID PROJECT	SRTS-4009(302)	

CONTRACT #87610

INDEX OF SHEETS

1. COVER SHEET
2. SUMMARY OF QUANTITIES & GENERAL NOTES
3. TYPICAL SECTIONS
- 4.-9. SIDEWALK PLAN AND PROFILE
10. CONSTRUCTION DETAILS
11. IDOT STANDARD DETAILS

HIGHWAY STANDARDS

- 424001-08 PERPENDICULAR CURB RAMPS FOR SIDEWALKS
- 424006-02 DIAGONAL CURB RAMPS FOR SIDEWALKS
- 424011-02 CORNER PARALLEL CURB RAMPS FOR SIDEWALKS
- 424016-02 MID-BLOCK CURB RAMPS FOR SIDEWALKS
- 424021-03 DEPRESSED CORNER FOR SIDEWALKS
- 602301-04 INLET - TYPE A
- 604001-04 FRAMES AND LIDS - TYPE 1
- 606001-06 CONCRETE CURB TYPE B AND COMBINATION CONCRETE CURB AND GUTTER
- 701006-05 OFF ROAD OPERATIONS, 2L, 2W, 15' TO 24" FROM PAVEMENT EDGE
- 701301-04 LANE CLOSURE, 2L, 2W, SHORT TIME OPERATIONS
- 701501-06 URBAN LANE CLOSURE, 2L, 2W, UNDIVIDED
- 701801-06 SIDEWALK, CORNER OR CROSSWALK CLOSURE
- 701901-05 TRAFFIC CONTROL DEVICES
- 878001-10 CONCRETE FOUNDATION DETAILS

COAL CITY
SAFE ROUTES TO SCHOOL
SIDEWALK - VARIOUS STREETS
PROJECT NO.: SRTS-4009(302)
SECTION NO.: 14-00032-00-SW
VILLAGE of COAL CITY
GRUNDY COUNTY
JOB NO.: C-93-041-15

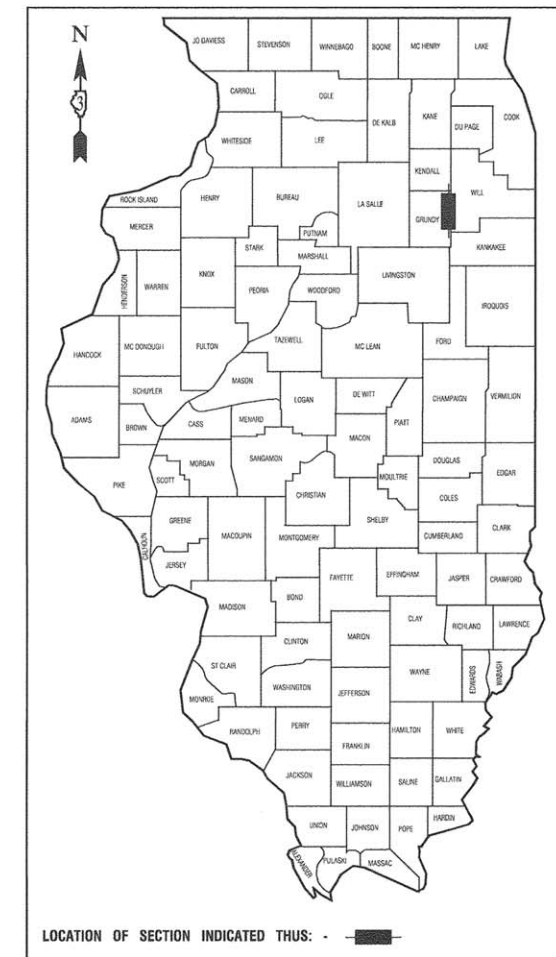

SCALES
PLAN - 1"=50'
PROFILE HORIZ. - 1"=50'
PROFILE VERT. - 1"=5'
CROSS SECTIONS - 1"=10'

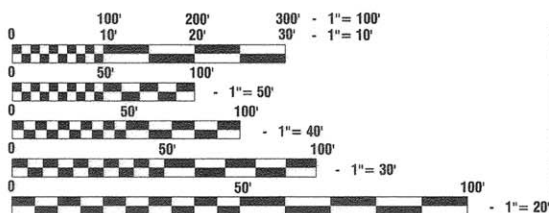

SIDEWALK IMPROVEMENTS AT VARIOUS LOCATIONS:

- FOURTH STREET,
- THIRD STREET,
- KANKAKEE STREET,
- GARFIELD STREET
- INTERSECTION AT BROADWAY & SECOND ST.
- INTERSECTION AT BROADWAY & THIRD ST.
- INTERSECTION AT BROADWAY & FOURTH ST.

FULL SIZE PLANS HAVE BEEN PREPARED USING STANDARD ENGINEERING SCALES, REDUCED SIZED PLANS WILL NOT CONFORM TO STANDARD SCALES, IN MAKING MEASUREMENTS ON REDUCED PLANS, THE ABOVE SCALES MAY BE USED.

J. U. L. I. E.
JOINT UTILITY LOCATION INFORMATION FOR EXCAVATION
1 - 800 - 892 - 0123 or 811

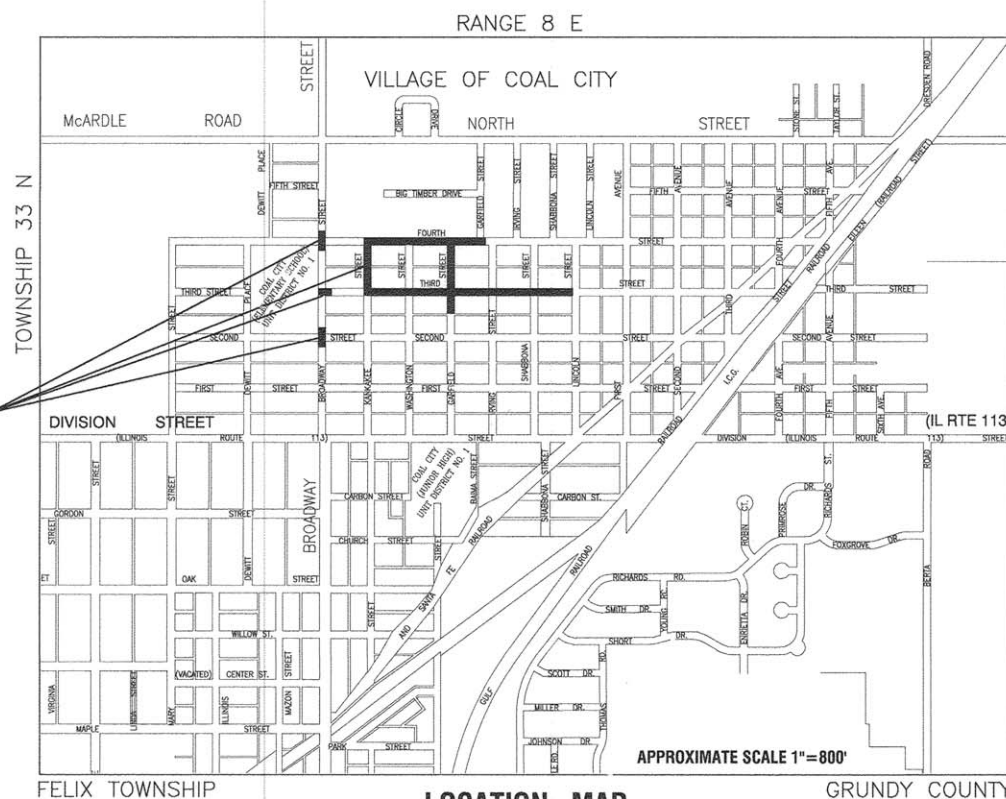

LOCATION MAP

GROSS LENGTH=4,000 FEET=0.758 MILES
NET LENGTH=4,000 FEET=0.758 MILES



STATE OF ILLINOIS DEPARTMENT OF TRANSPORTATION
DIVISION OF HIGHWAYS

Approved: May 19, 2016
[Signature]
President, Village of Coal City

Passed: 5/15/2016
[Signature]
District 3 Engineer of Local Roads & Streets

Released for Bid Based on Limited Review: 5/15/2016
[Signature]
Region 2 Engineer

PRINTED BY THE AUTHORITY OF
THE STATE OF ILLINOIS

PREPARED BY OR UNDER THE
DIRECT SUPERVISION OF:

[Signature]
5/19/16



I.D.O.T. FEDERAL AID DESIGN ENGINEER:
CONSULTANTS: ROBINSON ENGINEERING, LTD. 708-331-6700

CONTRACT NO. 87610

SUMMARY OF QUANTITIES					CONSTRUCTION TYPE CODE
S.I.	CODE NO.	ITEM	UNIT	QUAN	0021
	20101200	TREE ROOT PRUNING	EACH	6	6
	20101350	TREE PRUNING (OVER 10 INCH DIAMETER)	EACH	6	6
	20800150	TRENCH BACKFILL	CU YD	4	4
	28000510	INLET FILTERS	EACH	16	16
	35101598	AGGREGATE BASE COURSE, TYPE B 3"	SQ YD	2163	2163
	40200900	AGGREGATE SURFACE COURSE,TYPE B	CU YD	9	9
	40201000	AGGREGATE FOR TEMPORARY ACCESS	TON	100	100
	42300200	PORTLAND CEMENT CONCRETE DRIVEWAY PAVEMENT, 6 INCH	SQ YD	145	145
	42400200	PORTLAND CEMENT CONCRETE SIDEWALK 5 INCH	SQ FT	15777	15777
	42400300	PORTLAND CEMENT CONCRETE SIDEWALK 6 INCH	SQ FT	2238	2238
	42400800	DETECTABLE WARNINGS	SQ FT	230	230
	44000200	DRIVEWAY PAVEMENT REMOVAL	SQ YD	436	436
	44000500	COMBINATION CURB AND GUTTER REMOVAL	FOOT	25	25
	44000600	SIDEWALK REMOVAL	SQ FT	150	150
	550A0050	STORM SEWERS, CLASS A, TYPE 1, 12"	FOOT	15	15
	56500600	DOMESTIC WATER SERVICE BOXES TO BE ADJUSTED	EACH	1	1
	60234200	INLETS, TYPE A, TYPE 1 FRAME, OPEN LID	EACH	1	1
	60250500	CATCH BASINS TO BE ADJUSTED WITH NEW TYPE 1 FRAME AND CLOSED LID	EACH	1	1
	60255500	MANHOLES TO BE ADJUSTED	EACH	1	1
	60266600	VALVE BOXES TO BE ADJUSTED	EACH	1	1
	60603800	COMBINATION CONCRETE CURB AND GUTTER, TYPE B-6.12	FOOT	25	25
	67100100	MOBILIZATION	LSUM	1	1
	72400500	RELOCATE SIGN PANEL ASSEMBLY - TYPE A	EACH	1	1
*	78000400	THERMOPLASTIC PAVEMENT MARKING - LINE 6"	FOOT	1145	1145
*	78000600	THERMOPLASTIC PAVEMENT MARKING - LINE 12"	FOOT	275	275
*	78000650	THERMOPLASTIC PAVEMENT MARKING - LINE 24"	FOOT	90	90
*	87800100	CONCRETE FOUNDATION, TYPE A	FOOT	6	6
	Z0004510	HOT-MIX ASPHALT DRIVEWAY PAVEMENT, 3"	SQ YD	121	121
*	X0326899	SOLAR POWERED FLASHING BEACON ASSEMBLY (COMPLETE)	EACH	2	2
	X0327301	RELOCATE EXISTING MAILBOX	EACH	5	5
	X0327545	SOIL SAMPLING AND TESTING	EACH	1	1
	X2020410	EARTH EXCAVATION (SPECIAL)	CU YD	350	350
	X7010216	TRAFFIC CONTROL AND PROTECTION (SPECIAL)	LSUM	1	1
	XX006425	RESTORATION	SQ YD	800	800

* - INDICATES SPECIALTY ITEMS

GENERAL NOTES

- BOTH THE ROBINSON ENGINEERING, LTD. FIELD OFFICE (708-331-6700) AND THE VILLAGE OF COAL CITY (815-634-8608) SHALL BE NOTIFIED TWO (2) WORKING DAYS BEFORE CONSTRUCTION BEGINS.
- AREAS DISTURBED BY CONSTRUCTION SHALL BE KEPT TO A MINIMUM. ALL AREAS DISTURBED UNNECESSARILY SHALL BE RESTORED AS REQUIRED IN THE SPECIAL PROVISION AT THE CONTRACTOR'S EXPENSE.
- ACCESS TO EXISTING DRIVEWAYS, AND ALL PUBLIC FACILITIES SHALL BE MAINTAINED AT ALL TIMES BY PLACEMENT OF TEMPORARY AGGREGATE. THE CONTRACTOR SHALL PERIODICALLY MONITOR ALL AFFECTED AREAS DURING THE PROJECT, AND SHALL PLACE ADDITIONAL AGGREGATE WHEN NECESSARY.
- UTILITIES INDICATED ON THE PLANS ARE PROVIDED FOR THE CONTRACTOR'S USE AND ARE BASED UPON INFORMATION AVAILABLE AT THE TIME OF THE ADVERTISEMENT FOR BIDS. THE OWNER AND ENGINEER DO NOT GUARANTEE THE ACCURACY OF UTILITIES INFORMATION. IT SHALL BE THE CONTRACTOR'S RESPONSIBILITY TO NOTIFY J.U.L.I.E. AT LEAST 48 HOURS PRIOR TO EXCAVATION TO VERIFY LOCATIONS OF ALL UTILITIES. IF DETERMINED NECESSARY UTILITY RELOCATIONS SHALL BE PERFORMED BY PRIVATE UTILITY OWNERS. NO ADDITIONAL COMPENSATION SHALL BE ALLOWED DUE TO DELAYS OR INCONVENIENCES CAUSED BY SUCH ADJUSTMENTS.
- CONTRACTOR SHALL BE RESPONSIBLE AT ALL TIMES FOR TRAFFIC CONTROL AND PROTECTION IN ACCORDANCE WITH IDOT STANDARD SPECIFICATIONS ADOPTED JANUARY 1, 2016, THE LATEST EDITION OF THE ILLINOIS MANUAL ON UNIFORM TRAFFIC CONTROL DEVICES FOR STREETS AND HIGHWAYS, AND THE STANDARD SPECIFICATIONS FOR TRAFFIC CONTROL ITEMS.
- THE TOP OF ALL STRUCTURES SHALL BE FLUSH WITH THE ADJACENT SURFACE OR THE INDICATED ELEVATION SHOWN ON THE PLANS. FRAME ELEVATIONS ARE GIVEN ONLY TO ASSIST IN DETERMINING THE OVERALL HEIGHT OF THE STRUCTURE. FRAMES ON ALL NEW STRUCTURES SHALL BE ADJUSTED TO THE FINAL SURFACE ELEVATION AS PART OF THE NEW STRUCTURE COST.
- ITEMS OF WORK LISTED IN THE SUMMARY OF QUANTITIES NOT SPECIFICALLY CALLED OUT ON THE PLANS SHALL BE PERFORMED AS DIRECTED BY THE ENGINEER.
- THE CONTRACTOR SHALL MAKE EVERY ATTEMPT NOT TO DAMAGE EXISTING TREES.
- CONTRACTOR SHALL PROVIDE THE ENGINEER WITH VIDEOTAPE DETAILING ALL SURFACE CONDITIONS WITHIN THE PROJECT AREA PRIOR TO CONSTRUCTION. ALL RESTORATION SHALL BE COMPLETED TO THE SATISFACTION OF THE OWNER AND ENGINEER.
- IT SHALL BE THE CONTRACTOR'S RESPONSIBILITY TO VERIFY ALL DIMENSIONS AND CONDITIONS EXISTING IN THE FIELD PRIOR TO CONSTRUCTION AND ORDERING OF MATERIALS.
- THE REMOVAL AND/OR REPLACEMENT OF ANY DRIVEWAYS, PAVEMENT, CURB, SIDEWALK, ECT. SHALL BE ACCOMPLISHED BY MEANS OF A SAW CUT JOINT, AT THE DIRECTION OF THE ENGINEER. THIS WORK WILL NOT BE PAID FOR SEPARATELY, BUT SHALL BE INCLUDED IN THE UNIT PRICE FOR THE VARIOUS ITEMS BEING REMOVED.
- ANY LOOSE MATERIAL DEPOSITED IN THE FLOW LINE OF DITCHES, GUTTERS OR OTHER DRAINAGE STRUCTURES SHALL BE REMOVED BY THE END OF EACH DAY BY THE CONTRACTOR AT THEIR EXPENSE.
- CONSTRUCTION ACTIVITIES SHALL BE LIMITED TO ONE SIDE OF THE STREET AT A TIME.
- THE CONTRACTOR MAY PROSECUTE WORK BETWEEN THE HOURS OF 7:00 A.M. AND DUSK EACH WORKDAY. NO WORK WILL BE PERMITTED ON SUNDAYS, OR ON HOLIDAYS, WITHOUT PRIOR WRITTEN PERMISSION FROM THE ENGINEER.

DISTRICT 3 - GENERAL NOTES

- BEFORE ORDERING PIPE CULVERTS OR PIPE DRAINS, THE CONTRACTOR SHALL CONSULT THE ENGINEER FOR EXACT LENGTHS.
- THE ENGINEER WILL BE THE SOLE JUDGE CONCERNING CURING TIME FOR THE VARIOUS HMA LIFTS.
- SEEDING WILL NOT BE PERMITTED AT ANY TIME WHEN THE GROUND IS FROZEN, WET, OR IN AN UNTILLABLE CONDITION. LOCATIONS TO BE SEEDED WILL BE DETERMINED BY THE ENGINEER.
- ONLY THOSE TREES DESIGNATED BY THE ENGINEER OR LISTED IN THE TREE REMOVAL SCHEDULE SHALL BE REMOVED. THE CONTRACTOR SHALL PROTECT ALL REMAINING TREES FROM DAMAGE DUE TO HIS OPERATIONS.
- DETECTABLE WARNING SURFACES SHALL EXTEND 2.0 FT MINIMUM IN THE DIRECTION OF PEDESTRIAN TRAVEL. AT CURB RAMPS AND BLENDED TRANSITIONS, DETECTABLE WARNING SURFACES SHALL EXTEND THE FULL WIDTH OF THE RAMP RUN (EXCLUDING ANY FLARES) OR BLENDED TRANSITIONS. SOME DETECTABLE WARNING PRODUCTS REQUIRE A CONCRETE BORDER FOR PROPER INSTALLATION. THE CONCRETE BORDER SHALL NOT EXCEED 2 INCHES.
- ANY REFERENCE TO A STANDARD IN THESE PLANS SHALL BE INTERPRETED TO MEAN THE EDITION AS INDICATED BY THE SUBNUMBER SHOWN IN THE LIST OF STANDARDS OR THE COPY INCLUDED IN THESE PLANS.
- THE WORK REQUIRED TO CONNECT ANY SEWER TO AN EXISTING DRAINAGE STRUCTURE OR PIPE WILL NOT BE PAID FOR SEPARATELY, BUT WILL BE CONSIDERED AS INCLUDED IN THE CONTRACT UNIT PRICE BID FOR THE SEWER ITEMS.
- THE CONTRACTOR SHALL CONTACT JULIE AT LEAST 48 HOURS PRIOR TO EXCAVATION TO DETERMINE WHICH UTILITIES ARE IN THE AREA.

BENCH MARKS:

BENCH MARK #2
CROSS SET IN CONCRETE SIDEWALK AT THE S.W. CORNER OF THE INTERSECTION OF BROADWAY ST. AND 4TH ST., 15' SOUTH OF THE SOUTH B.O.C. 4TH ST. AND 59' WEST OF THE POWER POLE W/ LIGHT AT THE S.E. CORNER OF THE INTERSECTION
ELEVATION=588.32

BENCH MARK #10
CROSS FOUND IN CONCRETE SIDEWALK AT THE N.E. CORNER OF THE INTERSECTION OF GARFIELD ST. AND 2ND ST., 23' EAST OF THE EAST E.O.P. GARFIELD ST., AND 24' NORTH OF THE NORTH E.O.P. OF 2ND ST.
ELEVATION=562.99

FILE NAME = 15275-DTLS-QT-QUAN	USER NAME =	DESIGNED -- KJB	REVISED --	STATE OF ILLINOIS DEPARTMENT OF TRANSPORTATION	VARIOUS STREETS SUMMARY OF QUANTITIES & GENERAL NOTES			F.A.U. RTE	SECTION	COUNTY	TOTAL SHEETS	SHEET NO.	
	PLOT SCALE =	CHECKED -- HLG	REVISED --		SCALE:	SHEET NO. 2	OF 11 SHEETS	STA.	TO STA.	14-00032-00-SW	GRUNDY	11	2
	PLOT DATE = 05-19-16	DRAWN -- ACAD	REVISED --		CONTRACT NO. 87610								
		CHECKED -- ACAD	REVISED --		FED. ROAD DIST NO. 3 ILLINOIS FED. AID PROJECT. SRTS 4009(302)								

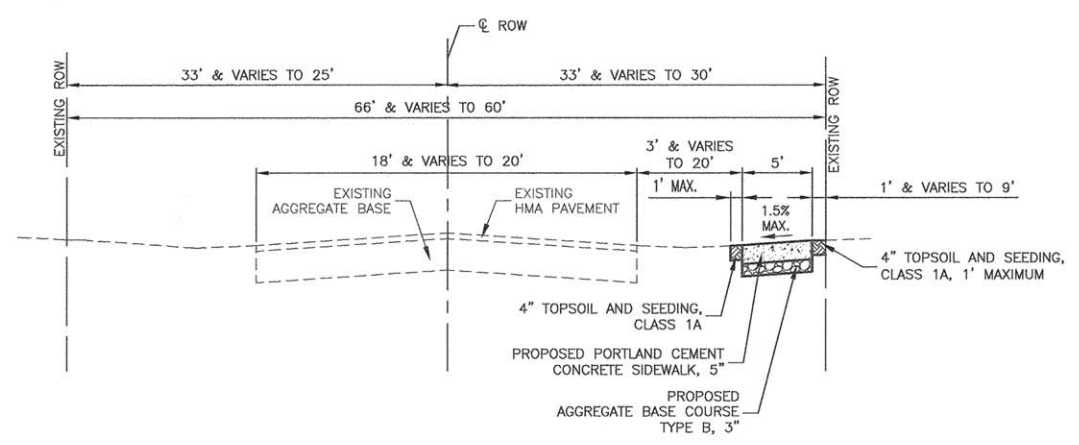
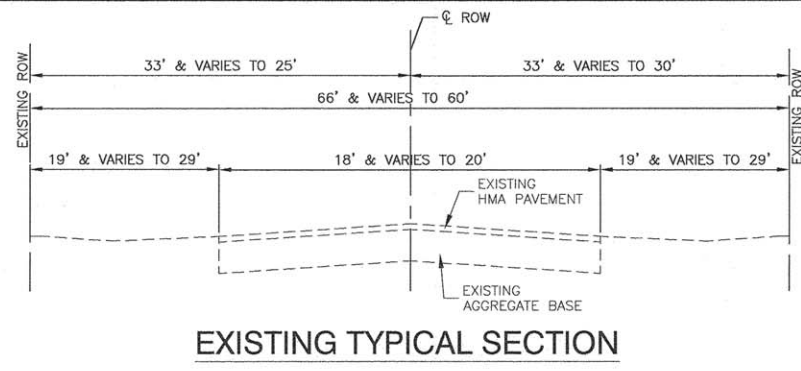

MIXTURE TABLE

	HMA DRIVEWAY PAVEMENT
PG GRADE	PG 64-22
DESIGN AIR Voids	4.0% @ N50
MIXTURE COMPOSITION	IL 9.5
FRICTION AGGREGATE	MIXTURE C
DENSITY TEST METHOD	SATISFACTION OF ENGINEER
MIXTURE WEIGHT	112#/SQ YD/ IN
QUALITY MANAGEMENT PROGRAM	QC/QA
SUBLOT SIZE	N/A
LOCATION(S)	ENTIRE PROJECT

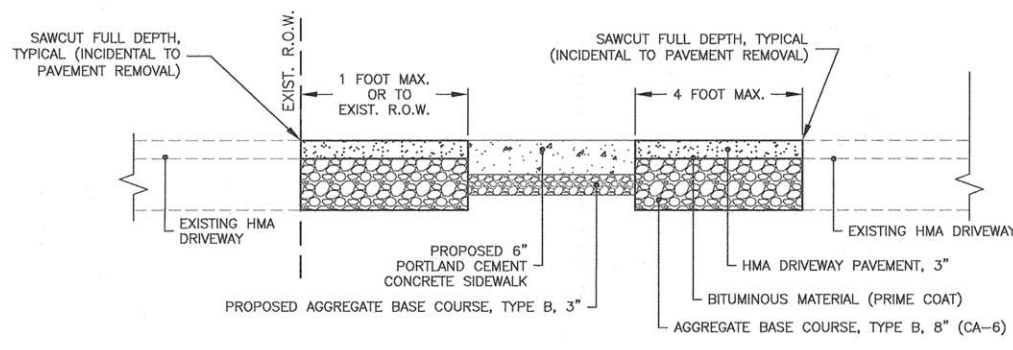

NOTE: ALONG EDGE OF REPLACEMENT DRIVEWAY, FURNISH AND PLACE, 4" TOPSOIL W/ SEEDING, CLASS 1A

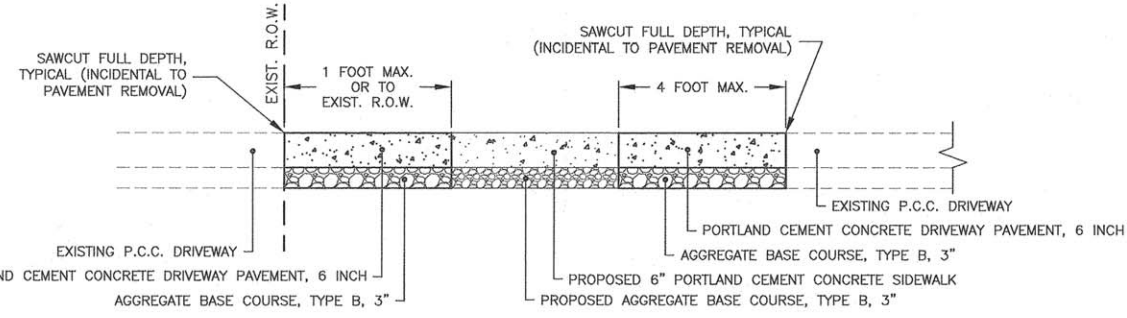

NOTE: ALONG EDGE OF REPLACEMENT DRIVEWAY, FURNISH AND PLACE, 4" TOPSOIL W/ SEEDING, CLASS 1A

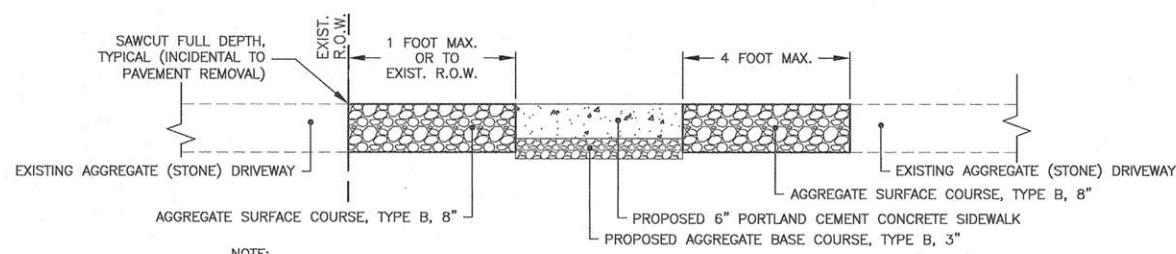

NOTE: ALONG EDGE OF REPLACEMENT DRIVEWAY, FURNISH AND PLACE, 4" TOPSOIL W/ SEEDING, CLASS 1A

PROPOSED TYPICAL SECTION - SIDEWALK AT DRIVEWAY

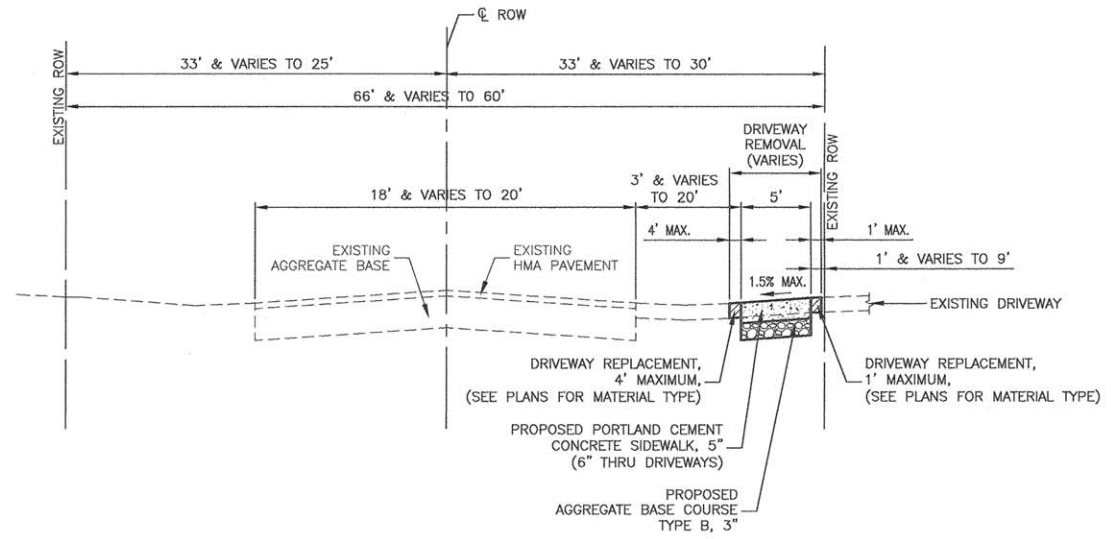

* NOTES:
SIDEWALKS WILL BE PLACED EITHER ON LEFT OR RIGHT SIDE OF ROADWAY, SEE PLANS FOR ACTUAL LOCATIONS.

PROPOSED TYPICAL SECTION - SIDEWALK AT DRIVEWAY

* NOTES:
1. SIDEWALKS WILL BE PLACED EITHER ON LEFT OR RIGHT SIDE OF ROADWAY, SEE PLANS FOR ACTUAL LOCATIONS.
2. EXISTING CONCRETE DRIVEWAYS SHALL REMAIN IN PLACE, UNLESS OTHERWISE INDICATED ON PLANS.
3. SIDEWALK SHALL MATCH EXISTING CONCRETE DRIVEWAYS, UNLESS OTHERWISE INDICATED ON PLANS.

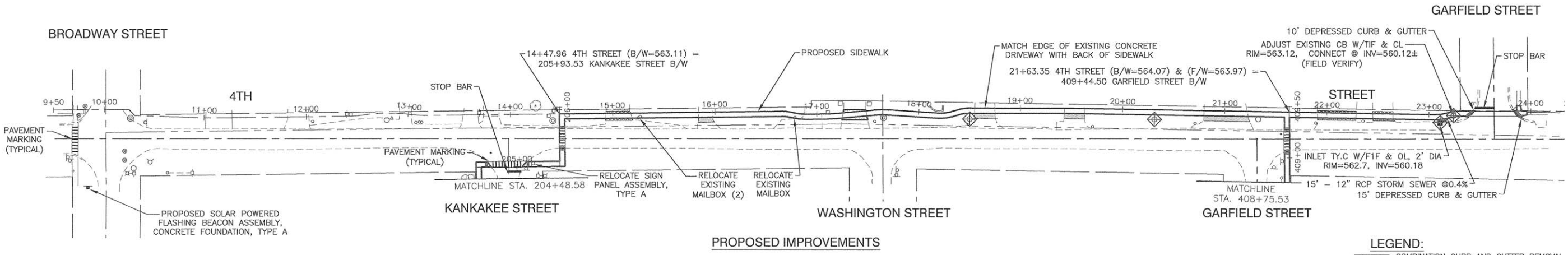
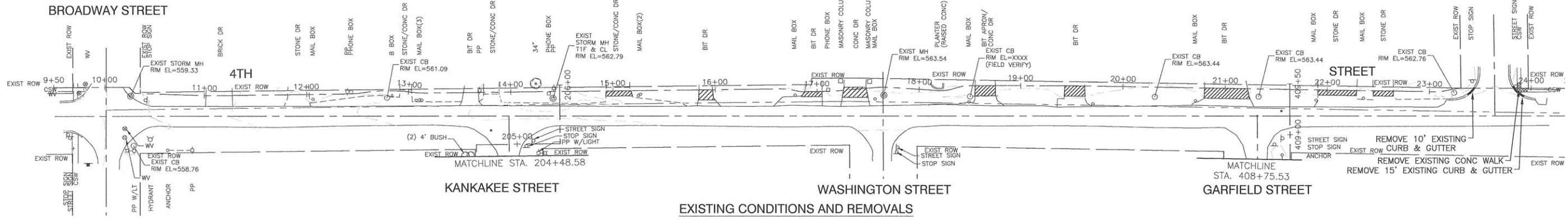

- LEGEND:**
- COMBINATION CURB AND GUTTER REMOVAL
 - DRIVEWAY PAVEMENT REMOVAL
 - CONCRETE SIDEWALK REMOVAL
 - P.C.C. DRIVEWAY REPLACEMENT
 - HMA DRIVEWAY REPLACEMENT
 - AGGREGATE (STONE) DRIVEWAY REPLACEMENT
 - DETECTABLE WARNING
 - INLET FILTER
 - TREE PROTECTION

NOTE: SIDEWALK SHALL MATCH EXISTING P.C.C. DRIVEWAYS

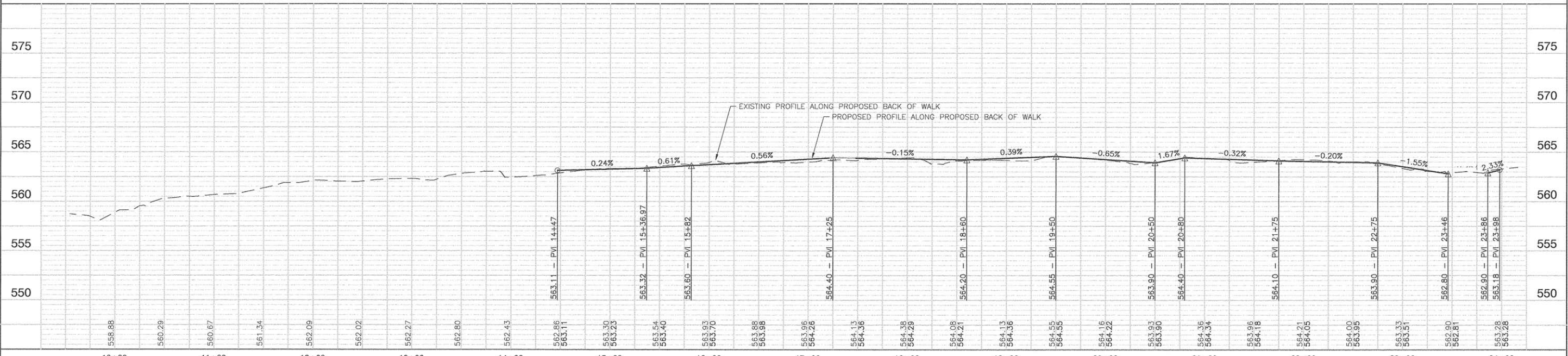

DATE	BY	REVISION

DATE	BY	REVISION

FILE NAME = 15275-PLPR-01 - IDOT PLPR(1)

USER NAME =	DESIGNED — KJB	REVISED —
CHECKED — HLG	REVISED —	
DRAWN — ACAD	REVISED —	
CHECKED — ACAD	REVISED —	
PLOT DATE = 11-05-15		

**STATE OF ILLINOIS
DEPARTMENT OF TRANSPORTATION**

**VARIOUS STREETS
4TH STREET
PLAN & PROFILE**

SCALE: H 1"=50' V 1"=5'
SHEET NO. 4 OF 11 SHEETS STA. TO STA.

F.A.U. RTE.	SECTION	COUNTY	TOTAL SHEETS	SHEET NO.
	14-00032-00-SW	GRUNDY	11	4
CONTRACT NO. 87610				

SECTION 35, TOWNSHIP 33, RANGE 8



DATE		BY
DATE	DATE	
PLANNED	DATE	BY
DATE	DATE	
NOTED	DATE	BY
DATE	DATE	
CHECKED	DATE	BY
DATE	DATE	
REVISED	DATE	BY
DATE	DATE	
PLAN		
DATE		
BY		

DATE		BY
DATE	DATE	
PLANNED	DATE	BY
DATE	DATE	
NOTED	DATE	BY
DATE	DATE	
CHECKED	DATE	BY
DATE	DATE	
REVISED	DATE	BY
DATE	DATE	
PROFILE		
DATE		
BY		

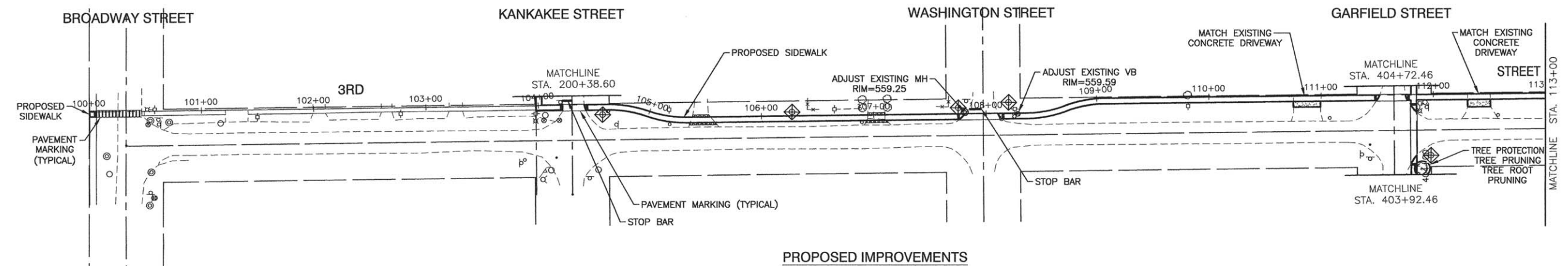
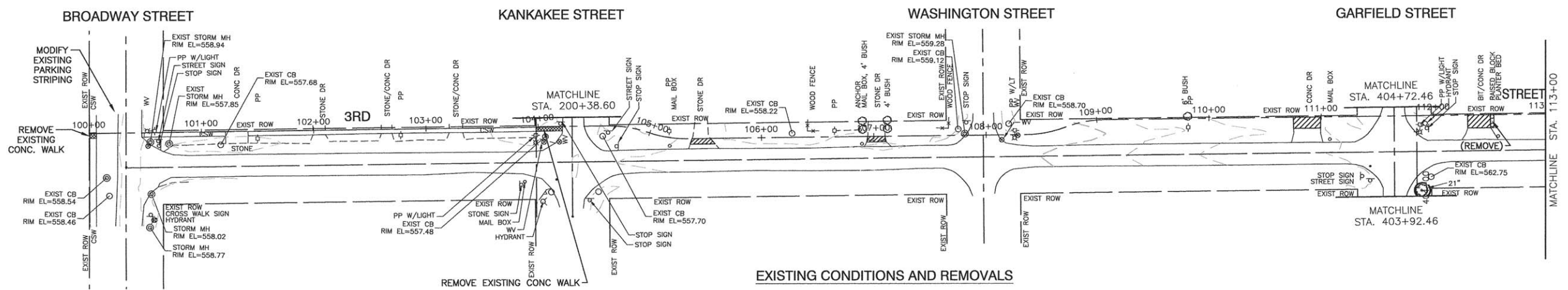

NOTE: SIDEWALK SHALL MATCH EXISTING P.C.C. DRIVEWAYS

- LEGEND:**
- COMBINATION CURB AND GUTTER REMOVAL
 - DRIVEWAY PAVEMENT REMOVAL
 - CONCRETE SIDEWALK REMOVAL
 - P.C.C. DRIVEWAY REPLACEMENT
 - HMA DRIVEWAY REPLACEMENT
 - AGGREGATE (STONE) DRIVEWAY REPLACEMENT
 - DETECTABLE WARNING
 - INLET FILTER
 - TREE PROTECTION

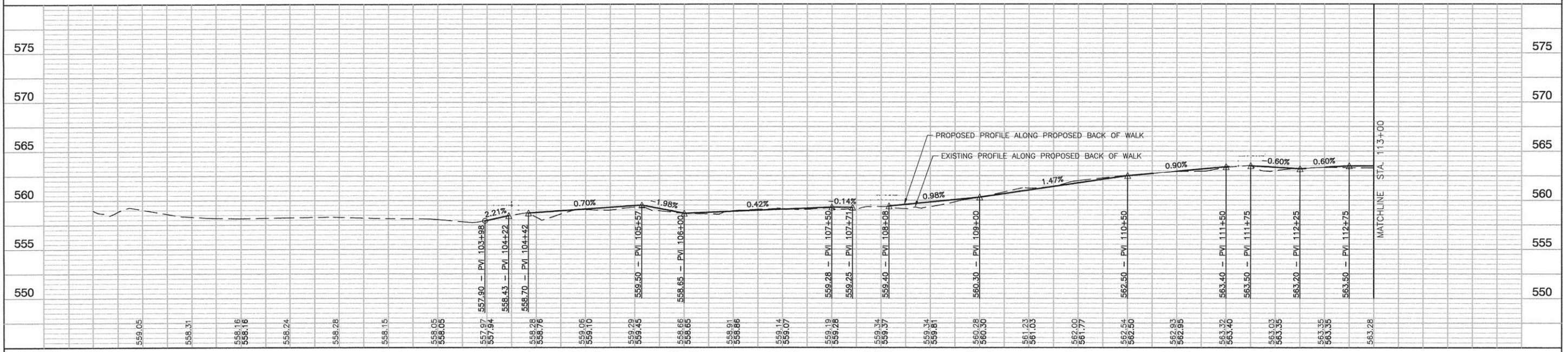

FILE NAME = 15275-PLPR-01 - IDOT PLPR(2)	USER NAME =	DESIGNED -- KJB	REVISED --	STATE OF ILLINOIS DEPARTMENT OF TRANSPORTATION	VARIOUS STREETS 3RD STREET PLAN & PROFILE	SCALE: H 1"=50' V 1"=5'	SHEET NO. 5 OF 11 SHEETS	STA. TO STA.	F.A.U. RTE.	SECTION	COUNTY	TOTAL SHEETS	SHEET NO.
	PLOT SCALE =	CHECKED -- HLG	REVISED --						14-00032-00-SW	GRUNDY	11	5	
	PLOT DATE = 11-05-15	DRAWN -- ACAD	REVISED --						CONTRACT NO. 87610				
		CHECKED -- ACAD	REVISED --						FED. ROAD DIST. NO. 3 ILLINOIS FED. AID PROJECT SRTS-4009(302)				

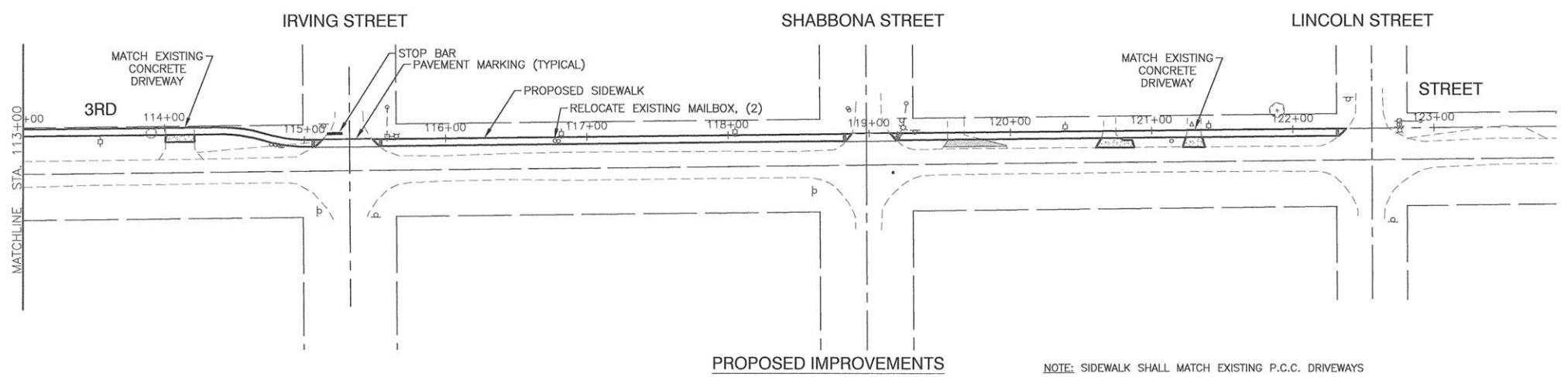
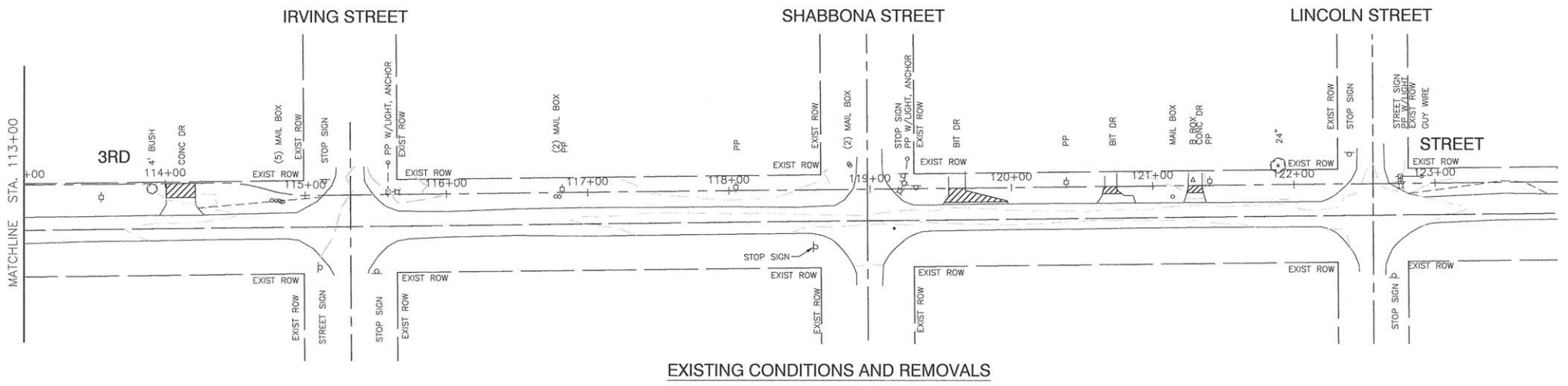

- LEGEND:**
- COMBINATION CURB AND GUTTER REMOVAL
 - DRIVEWAY PAVEMENT REMOVAL
 - CONCRETE SIDEWALK REMOVAL
 - P.C.C. DRIVEWAY REPLACEMENT
 - HMA DRIVEWAY REPLACEMENT
 - AGGREGATE (STONE) DRIVEWAY REPLACEMENT
 - DETECTABLE WARNING
 - INLET FILTER
 - TREE PROTECTION

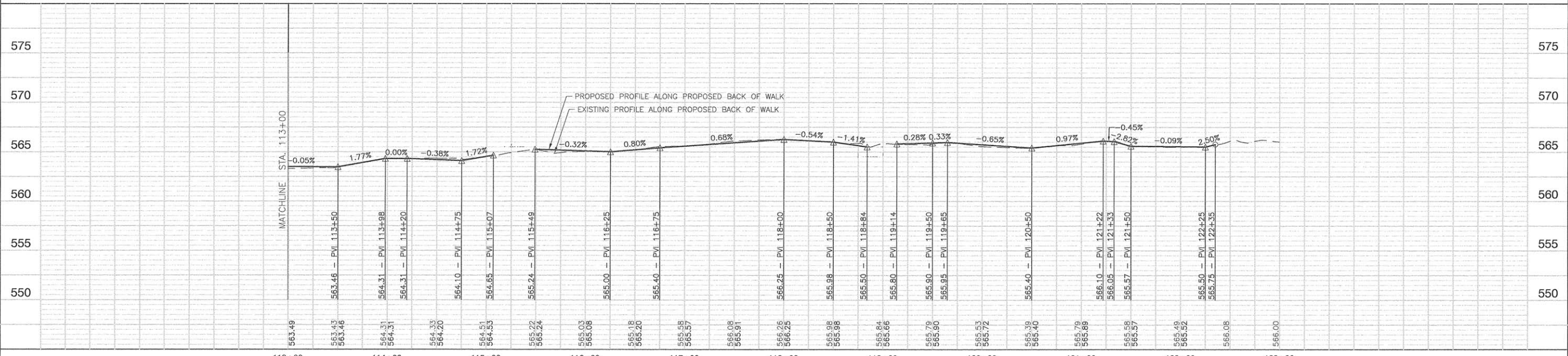

DATE	BY
DATE	BY
DATE	BY
DATE	BY
DATE	BY

DATE	BY
DATE	BY
DATE	BY
DATE	BY
DATE	BY

FILE NAME = 15275-PLPR-01 - IDOT PLPR(S)	USER NAME =	DESIGNED - KJB	REVISED -	STATE OF ILLINOIS DEPARTMENT OF TRANSPORTATION	VARIOUS STREETS 3RD STREET PLAN & PROFILE		F.A.U. RTE.	SECTION	COUNTY	TOTAL SHEETS	SHEET NO.	
		CHECKED - HLG	REVISED -		SCALE: H 1"=50' V 1"=5'	SHEET NO. 6	OF 11 SHEETS	STA.	TO STA.	14-00032-00-SW	11	6
		DRAWN - ACAD	REVISED -		CONTRACT NO. 87610							
		CHECKED - ACAD	REVISED -		FED. ROAD DIST. NO. 3 ILLINOIS FED. AID PROJECT SRTS-4009(302)							

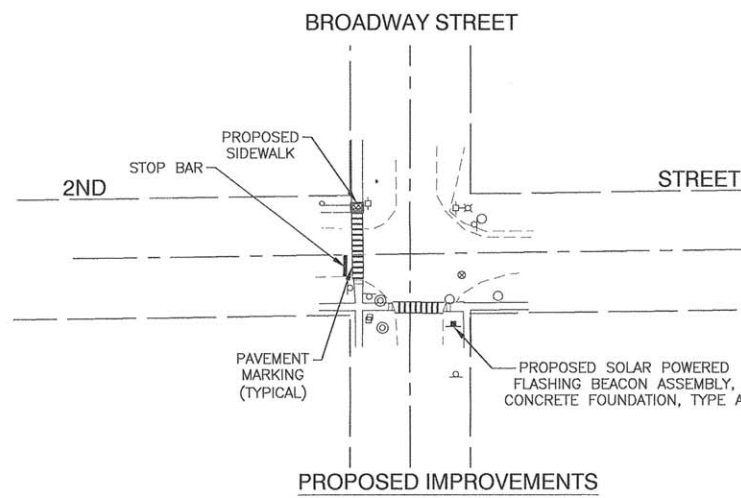
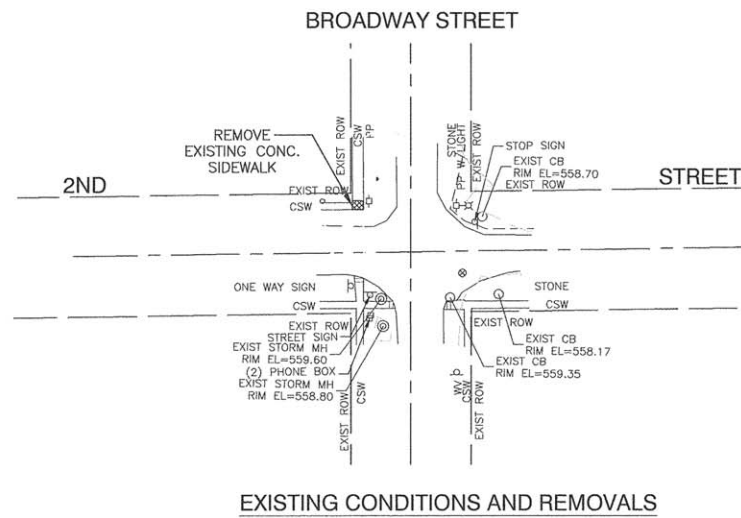

- LEGEND:**
- COMBINATION CURB AND GUTTER REMOVAL
 - DRIVEWAY PAVEMENT REMOVAL
 - CONCRETE SIDEWALK REMOVAL
 - P.C.C. DRIVEWAY REPLACEMENT
 - HMA DRIVEWAY REPLACEMENT
 - AGGREGATE (STONE) DRIVEWAY REPLACEMENT
 - DETECTABLE WARNING
 - INLET FILTER
 - TREE PROTECTION

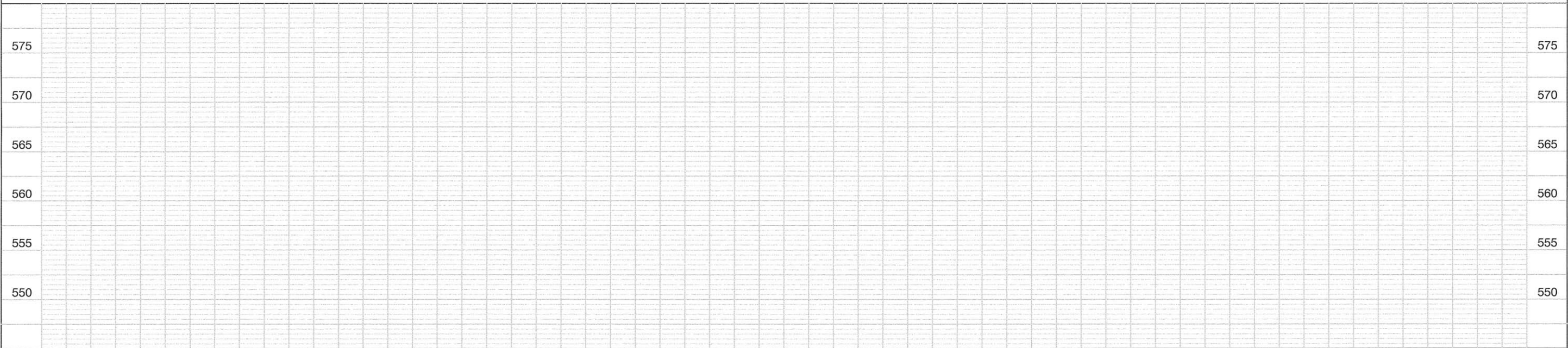

PLAN	DATE	BY
	DATE	BY
SURVEYED	NOTED	CHECKED
	ALIGNED	CHECKED
	RT. OF WAY	CHECKED
	ODD FILE NAME	
NO.		

PROFILE	DATE	BY
	DATE	BY
SURVEYED	NOTED	CHECKED
	PROF.	CHECKED
	B.M.	NOTED
NO.		

FILE NAME = 15275-PLPR-01 - IDOT PLPR(4)	USER NAME =	DESIGNED -- KJB	REVISED --
		CHECKED -- HLG	REVISED --
		DRAWN -- ACAD	REVISED --
		CHECKED -- ACAD	REVISED --
	PLOT SCALE =		
	PLOT DATE = 11-05-15		

STATE OF ILLINOIS
DEPARTMENT OF TRANSPORTATION

VARIOUS STREETS
INTERSECTION OF BROADWAY STREET & SECOND STREET
PLAN & PROFILE

SCALE: H 1"=50' V 1"=5' SHEET NO. 7 OF 11 SHEETS STA. TO STA.

F.A.U. RTE.	SECTION	COUNTY	TOTAL SHEETS	SHEET NO.
----	14-00032-00-SW	GRUNDY	11	7
CONTRACT NO. 87610				
FED. ROAD DIST. NO. 3 ILLINOIS FED. AID PROJECT SRTS-4009(302)				

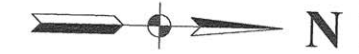

PLAN	SUBMITTED	DATE
NOTE BOOK NO.	PLANNED	
	CHECKED	
	BY	
	DATE	

PROFILE	SUBMITTED	DATE
NOTE BOOK NO.	PLOTTED	
	CHECKED	
	BY	
	DATE	

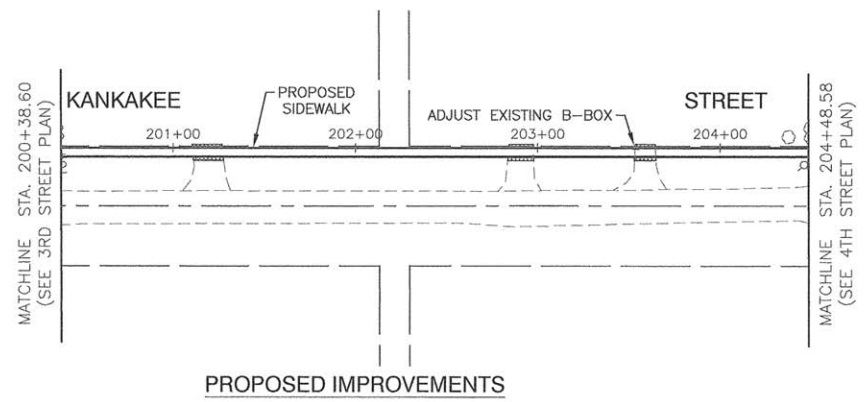
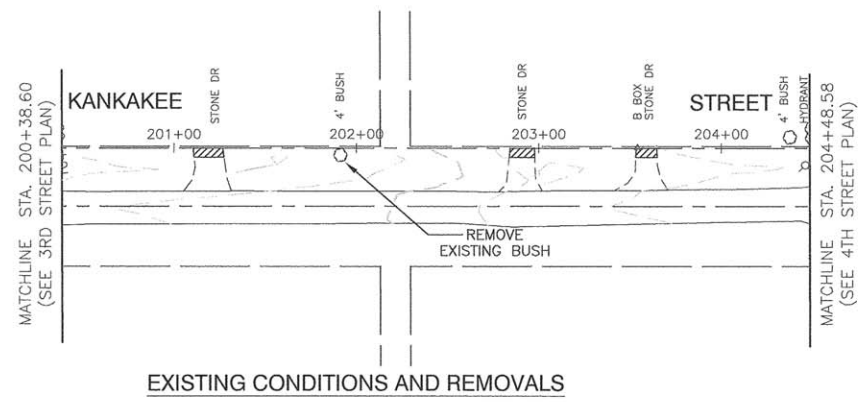

- LEGEND:**
- COMBINATION CURB AND GUTTER REMOVAL
 - DRIVEWAY PAVEMENT REMOVAL
 - CONCRETE SIDEWALK REMOVAL
 - P.C.C. DRIVEWAY REPLACEMENT
 - HMA DRIVEWAY REPLACEMENT
 - AGGREGATE (STONE) DRIVEWAY REPLACEMENT
 - DETECTABLE WARNING
 - INLET FILTER
 - TREE PROTECTION

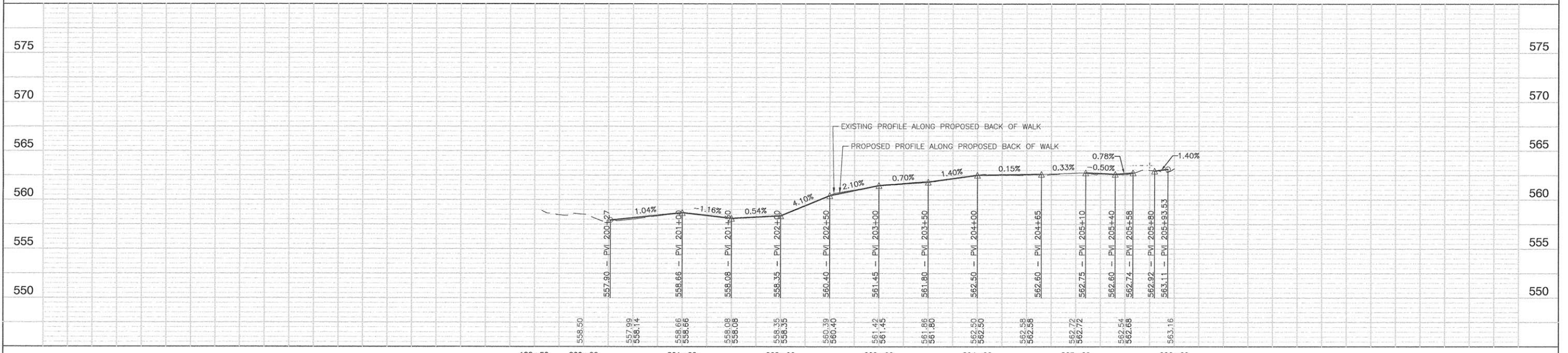

FILE NAME = 15275-PLPR-01 - IDOT PLPR(S)	USER NAME =	DESIGNED -- KJB	REVISED --	199+50	200+00	201+00	202+00	203+00	204+00	205+00	206+00	F.A.U. RITE.	SECTION	COUNTY	TOTAL SHEETS	SHEET NO.	
	PLOT SCALE =	CHECKED -- HLG	REVISED --	STATE OF ILLINOIS DEPARTMENT OF TRANSPORTATION VARIOUS STREETS KANKAKEE STREET PLAN & PROFILE								14-00032-00-SW	GRUNDY	11	8		
	PLOT DATE = 11-05-15	DRAWN -- ACAD	REVISED --									SCALE: H 1"=50' V 1"=5'	SHEET NO. 8	OF 11 SHEETS	STA.	TO STA.	CONTRACT NO. 87610
		CHECKED -- ACAD	REVISED --									FED. ROAD DIST. NO. 3	ILLINOIS	FED. AID PROJECT	SRTS-4009(302)		

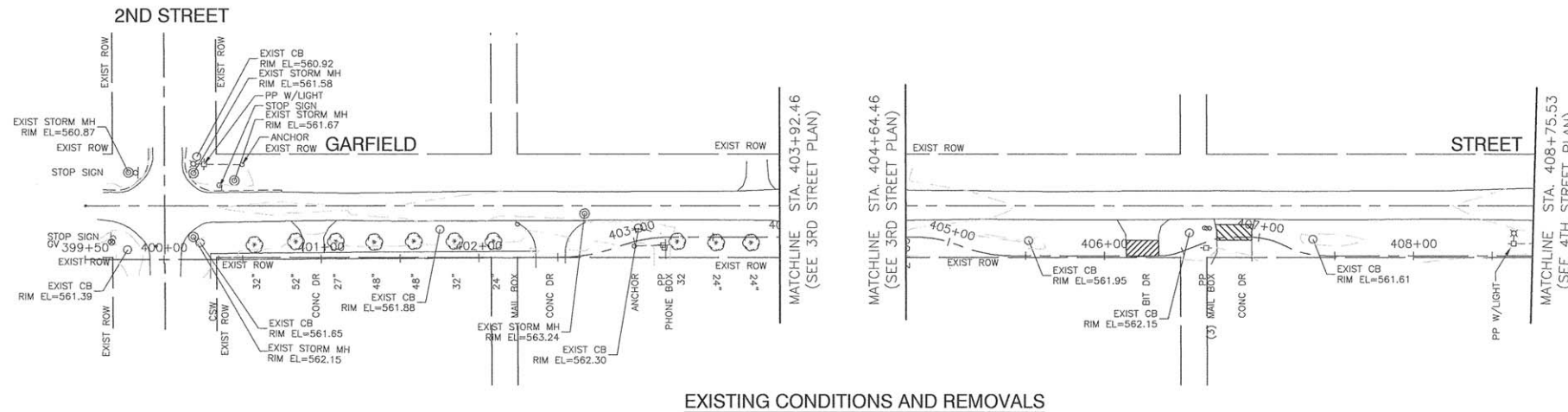

EXISTING CONDITIONS AND REMOVALS

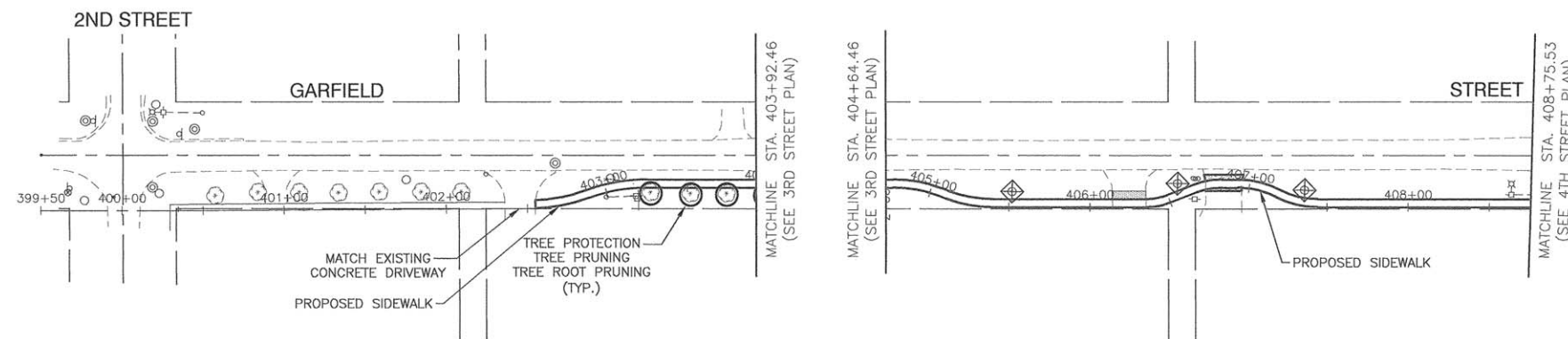

PROPOSED IMPROVEMENTS

- LEGEND:**
- COMBINATION CURB AND GUTTER REMOVAL
 - DRIVEWAY PAVEMENT REMOVAL
 - CONCRETE SIDEWALK REMOVAL
 - P.C.C. DRIVEWAY REPLACEMENT
 - HMA DRIVEWAY REPLACEMENT
 - AGGREGATE (STONE) DRIVEWAY REPLACEMENT
 - DETECTABLE WARNING
 - INLET FILTER
 - TREE PROTECTION

NOTE: SIDEWALK SHALL MATCH EXISTING P.C.C. DRIVEWAYS

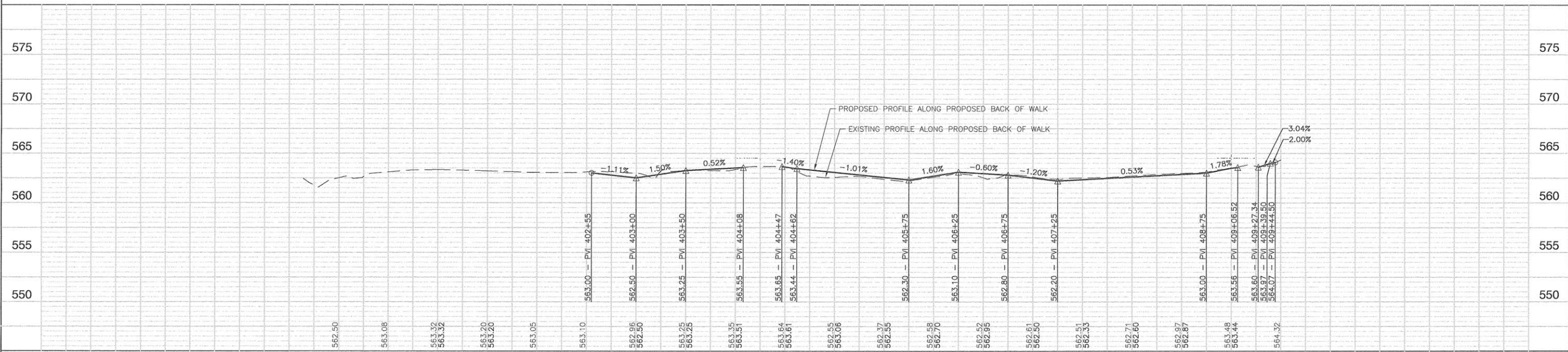

DATE	
BY	
SUBMITTED	
FOR REVIEW	
ALIGNMENT CHECKED	
RT. OF WAY CHECKED	
ADD FILE NAME	
PLAN	
NOTE BOOK	
NO.	

DATE	
BY	
SUBMITTED	
FOR REVIEW	
PROFILES CHECKED	
B.M. NOTED	
PROFILE	
NOTE BOOK	
NO.	

FILE NAME = 15275-PLPR-01 - I01 PLPR(6)	USER NAME =	DESIGNED -- KJB	REVISED --	STATE OF ILLINOIS DEPARTMENT OF TRANSPORTATION	VARIOUS STREETS GARFIELD STREET PLAN & PROFILE	F.A.U. RTE.	SECTION	COUNTY	TOTAL SHEETS	SHEET NO.	
	PLOT SCALE =	CHECKED -- HLG	REVISED --			14-00032-00-SW	GRUNDY	11	9		
	PLOT DATE = 11-05-15	DRAWN -- ACAD	REVISED --			CONTRACT NO. 87610					
						SCALE: H 1"=50' V 1"=5'	SHEET NO. 9	OF 11 SHEETS	STA.	TO STA.	
						FED. ROAD DIST. NO. 3	ILLINOIS	FED. AID PROJECT	SRTS-4009(302)		

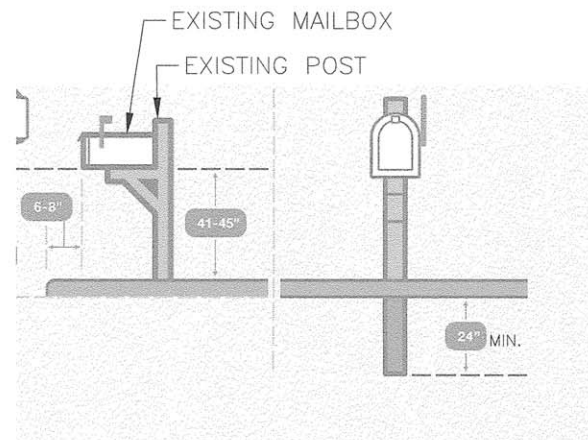

MAILBOX RELOCATION DETAIL

N.T.S.

NOTES:

1. REUSE EXISTING MAIL BOX AND POST.
2. RELOCATE EXISTING MAILBOX AT DIRECTION OF THE ENGINEER.
3. MAILBOXES AND POST WHICH ARE DAMAGED DURING RELOCATION SHALL BE REPLACED AT THE CONTRACTORS EXPENSE.

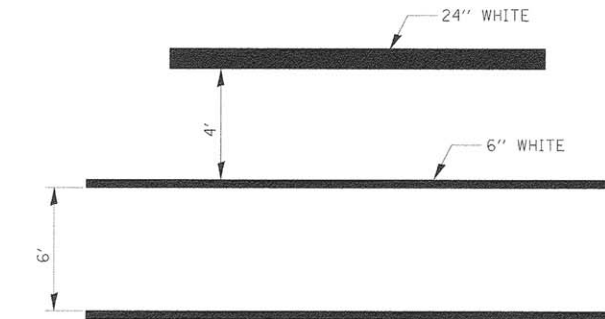

TYPICAL SPACING DETAIL FOR CROSSWALKS AND STOP BARS

**780-3
OPTION 1**

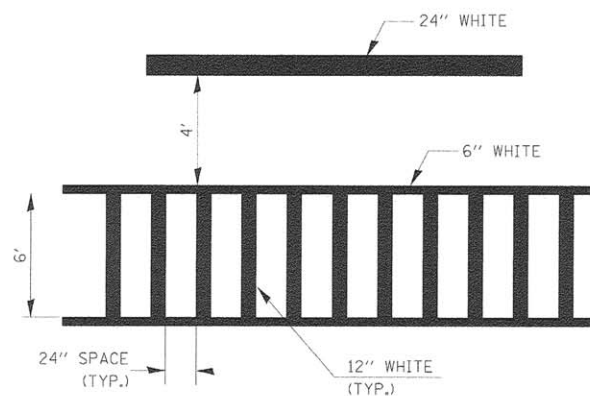

TYPICAL SPACING DETAIL FOR CROSSWALKS AND STOP BARS

**780-3
OPTION 2**

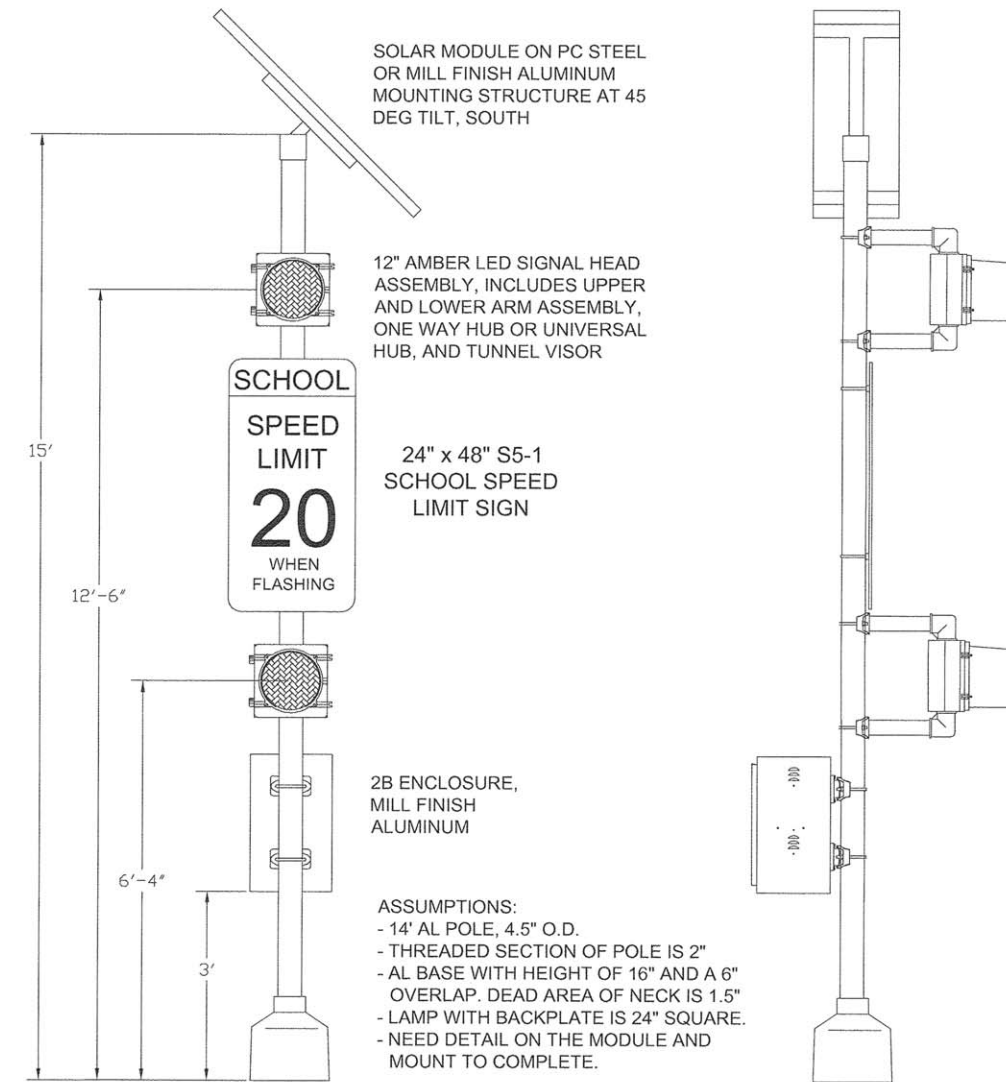

FRONT ELEVATION

SIDE ELEVATION

SOLAR POWERED FLASHING BEACON ASSEMBLY

NOTE: ALL SIGNS SHALL HAVE TYPE ZZ RETROREFLECTIVE SHEETING.

FILE NAME = 15275-DTLS-01 - IDOT DTLS-1

USER NAME =	DESIGNED -- KJB	REVISED --
	CHECKED -- HLG	REVISED --
PLOT SCALE =	DRAWN -- ACAD	REVISED --
PLOT DATE = 11-05-15	CHECKED -- ACAD	REVISED --

STATE OF ILLINOIS
DEPARTMENT OF TRANSPORTATION

VARIOUS STREETS
CONSTRUCTION DETAILS

F.A.U. RTE:	SECTION	COUNTY	TOTAL SHEETS	SHEET NO.
---	14-00032-00-SW	GRUNDY	11	10
CONTRACT NO. 87610				
FED. ROAD DIST. NO. 3 ILLINOIS FED. AID PROJECT SRTS-4009(302)				

SCALE: SHEET NO. 10 OF 11 SHEETS STA. TO STA.

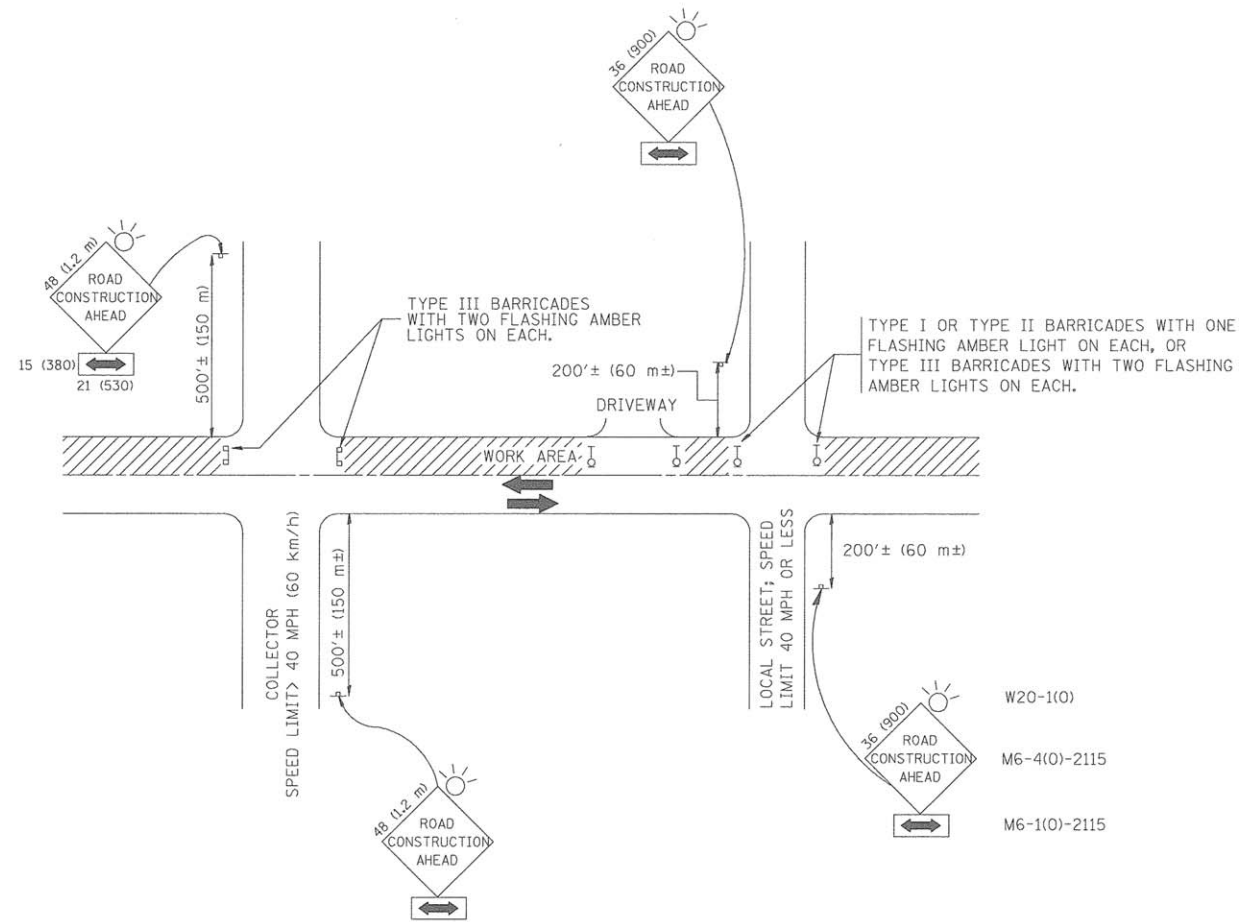

TRAFFIC CONTROL AND PROTECTION FOR SIDE ROADS, INTERSECTIONS, AND DRIVEWAYS

NOTES:

- A. FOR NO LANE RESTRICTION ON THE SIDE ROAD OR DRIVEWAYS
 1. SIDE ROAD WITH A SPEED LIMIT OF 40 MPH (60 km/h) OR LESS AS SHOWN ON THE DRAWING AND AS DIRECTED BY THE ENGINEER:
 - a) ONE **ROAD CONSTRUCTION AHEAD** SIGN 36 x 36 (900x900) WITH A FLASHER AND FLAG MOUNTED ON IT APPROXIMATELY 200' (60 m) IN ADVANCE OF THE MAIN ROUTE.
 - b) THE CLOSED PORTION OF THE MAIN ROUTE SHALL BE PROTECTED BY BLOCKING WITH TYPE I, TYPE II OR TYPE III BARRICADES, 1/3 OF THE CROSS SECTION OF THE CLOSED PORTION.
 2. SIDE ROAD WITH A SPEED LIMIT GREATER THAN 40 MPH (60 km/h) AS SHOWN ON THE DRAWING AND AS DIRECTED BY THE ENGINEER:
 - a) ONE **ROAD CONSTRUCTION AHEAD** SIGN 48 x 48 (1.2 m x 1.2 m) WITH A FLASHER MOUNTED ON IT APPROXIMATELY 500' (150 m) IN ADVANCE OF THE MAIN ROUTE.
 - b) THE CLOSED PORTION OF THE MAIN ROUTE SHALL BE PROTECTED BY BLOCKING WITH TYPE III BARRICADES, 1/2 OF THE CROSS SECTION OF THE CLOSED PORTION.
- 3. WHEN THE SIDE ROAD LIES BETWEEN THE BEGINNING OF THE MAINLINE SIGNING AND THE WORK ZONE, A SINGLE HEADED ARROW (M6-1) SHALL BE USED IN LIEU OF THE DOUBLE HEADED ARROW (M6-4).
- B. FOR A LANE CLOSURE ON A SIDE ROAD OR DRIVEWAY:
 - USE APPLICABLE PORTIONS OF THE TYPICAL APPLICATION OF TRAFFIC CONTROL DEVICES (STD. 701501, STD. 701606 OR THE APPROPRIATE STANDARD). THE SPACING OF SIGNS AND BARRICADES SHALL BE ADJUSTED FOR FIELD CONDITIONS AS DIRECTED BY THE ENGINEER. THE DIRECTIONAL ARROW SHALL BE COVERED OR REMOVED WHEN NO LONGER CONSISTENT WITH THE SIDE ROAD LANE CLOSURE.
 - C. ADVANCE WARNING SIGNS ARE TO BE OMITTED ON DRIVEWAY UNLESS OTHERWISE NOTED.
 - D. THE TRAFFIC CONTROL AND PROTECTION FOR SIDE ROADS, INTERSECTIONS, AND DRIVEWAYS SHALL BE INCIDENTAL TO THE COST OF SPECIFIED TRAFFIC CONTROL STANDARDS OR ITEMS.

All dimensions are in millimeters (inches) unless otherwise shown.

FILE NAME = 15275-DTLS-01 - TC-10	USER NAME = gaglianob	DESIGNED -- LHA	REVISED -- J. OBERLE 10-18-95
		CHECKED --	REVISED -- A. HOUSEH 03-06-96
	PLOT SCALE = 50.000' / IN.	DRAWN --	REVISED -- A. HOUSEH 10-15-96
	PLOT DATE = 1/4/2008	CHECKED -- 06-89	REVISED -- T. RAMMACHER 01-06-00

STATE OF ILLINOIS
DEPARTMENT OF TRANSPORTATION

TRAFFIC CONTROL AND PROTECTION FOR
SIDE ROADS, INTERSECTIONS, AND DRIVEWAYS

SCALE: SHEET NO. 11 OF 11 SHEETS STA. TO STA.

F.A.U. RTE.	SECTION	COUNTY	TOTAL SHEETS	SHEET NO.
---	14-00032-00-SW	GRUNDY	11	11
TC-10		CONTRACT NO. 87610		
FED. ROAD DIST. NO. 3	ILLINOIS	FED. AID PROJECT SRTS-4009(302)		