

DROP BOX NO. 3

SN 071-1163 - LT STA. 740+79 (IL RTE 2)
CULVERT @ 0° SKEW TO RDWY

BILL OF MATERIALS (FOR INFORMATION ONLY)

BAR	SIZE	NO.	LENGTH	SHAPE
d	#5	33	4'-4"	L
h	#7	12	7'-8"	—
h ₁	#7	13	6'-0"	—
h ₂	#4	15	7'-8"	—
h ₃	#4	18	6'-0"	—
h ₄	#4	4	5'-6"	—
h ₅	#4	4	2'-0"	—
v	#5	40	9'-0"	—
DESCRIPTION	UNIT	QTY		
CONCRETE BOX CULVERTS	CU YD	7.5		
REINFORCEMENT BARS	LB	1,040		
3 1/2" I.D. GALV STEEL PIPE	FOOT	13'-4"		
3 1/2" GALV PIPE CAPS	EACH	4		
1/4" GALV. STEEL PLATE (9" NOMINAL)	EACH	4		
1/2" X 4" X 14" GALV. STEEL PLATE	EACH	4		
EXPANSION BOLTS 1/2"Ø	EACH	8		

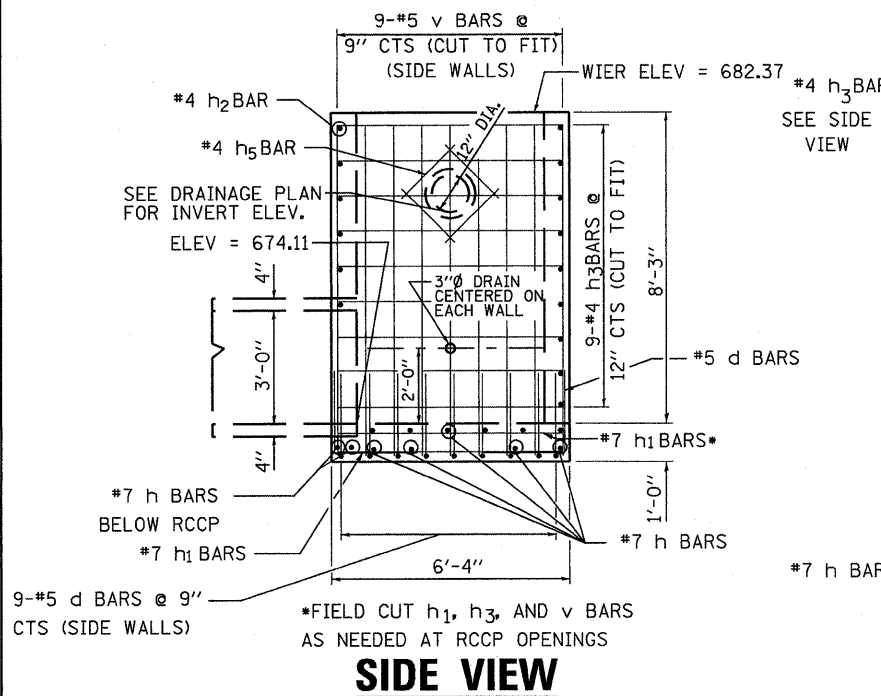

SIDE VIEW

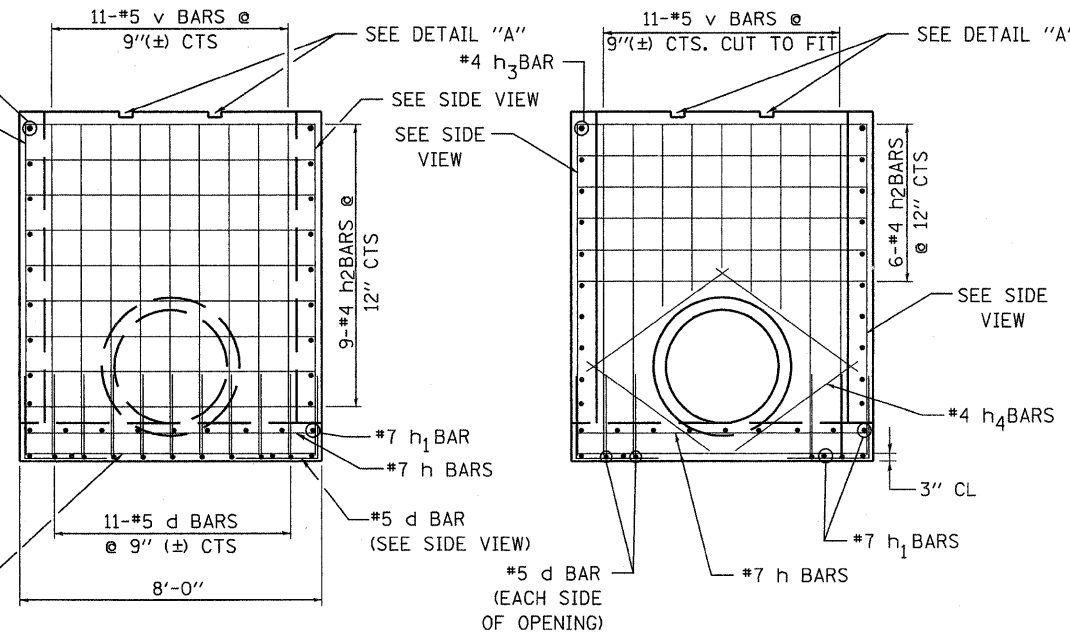

SECTION A-A

SECTION B-B

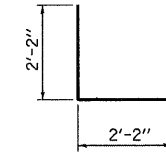

d BAR

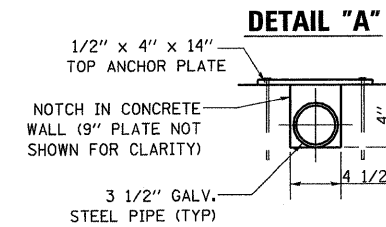

DETAIL "A"

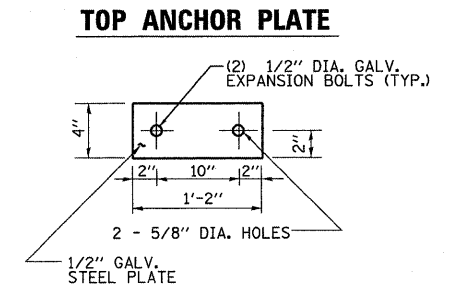

TOP ANCHOR PLATE

GENERAL NOTES:

THIS WORK SHALL BE PAID FOR AT THE CONTRACT UNIT PRICE PER "EACH" FOR **DROP BOX NO. 3**. THIS WORK SHALL INCLUDE THE GALVANIZED PIPE, ANCHOR PLATES, & CAPS, CONCRETE BOX CULVERTS, REINFORCEMENT BARS, BOLTS, NUTS, WASHERS, INSTALLATION ON THE PROPOSED CULVERT, PIPE GRATING, EARTH EXCAVATION AND DIVERTING WATER WHERE REQUIRED, AND ANY NECESSARY GRADING TO FIT THE DROP BOX, AS SHOWN IN THE CROSS SECTIONS OR TO SLOPE.

EXPOSED EDGES SHALL BE BEVELED 3/4".

SLOPE FLOW LINE FOR DROP BOX NO. 3 IS THE SAME RATE AS THE FLOW LINE OF THE PIPE.

BOLTS, NUTS, AND WASHERS SHALL BE IN ACCORDANCE WITH ARTICLE 1006.08 OF THE STANDARD SPECIFICATION AND SHALL BE GALVANIZED.

STEEL PIPES SHALL CONFORM TO A.S.T.M. A-53 (TYPE E OR S) GRADE B, SCHEDULE 40, AND SHALL BE GALVANIZED CONFORMING TO A.S.T.M. A-120. CONTRACTOR SHALL FIELD VERIFY PIPE LENGTH.

STEEL PLATES SHALL CONFORM TO AASHTO M-270 GRADE 36 AND SHALL BE GALVANIZED CONFORMING TO AASHTO M-111.

REINFORCEMENT BARS SHALL CONFORM TO THE REQUIREMENTS OF ASTM A706 GR. 60 (IL MODIFIED).

THE CONTRACTOR SHALL BE RESPONSIBLE FOR DIVERTING THE WATER FLOW FROM THE CONSTRUCTION AREA USING A METHOD MEETING THE APPROVAL OF THE ENGINEER. THIS WORK SHALL BE IN ACCORDANCE WITH ARTICLE 503 OF THE STANDARD SPECIFICATION. COST INCLUDED WITH "DROP BOX NO. 3."

SEE PLAN AND PROFILE SHEET FOR MORE INFORMATION.

SEE CROSS SECTION SHEET FOR MORE INFORMATION INCLUDING INVERT ELEVATIONS.

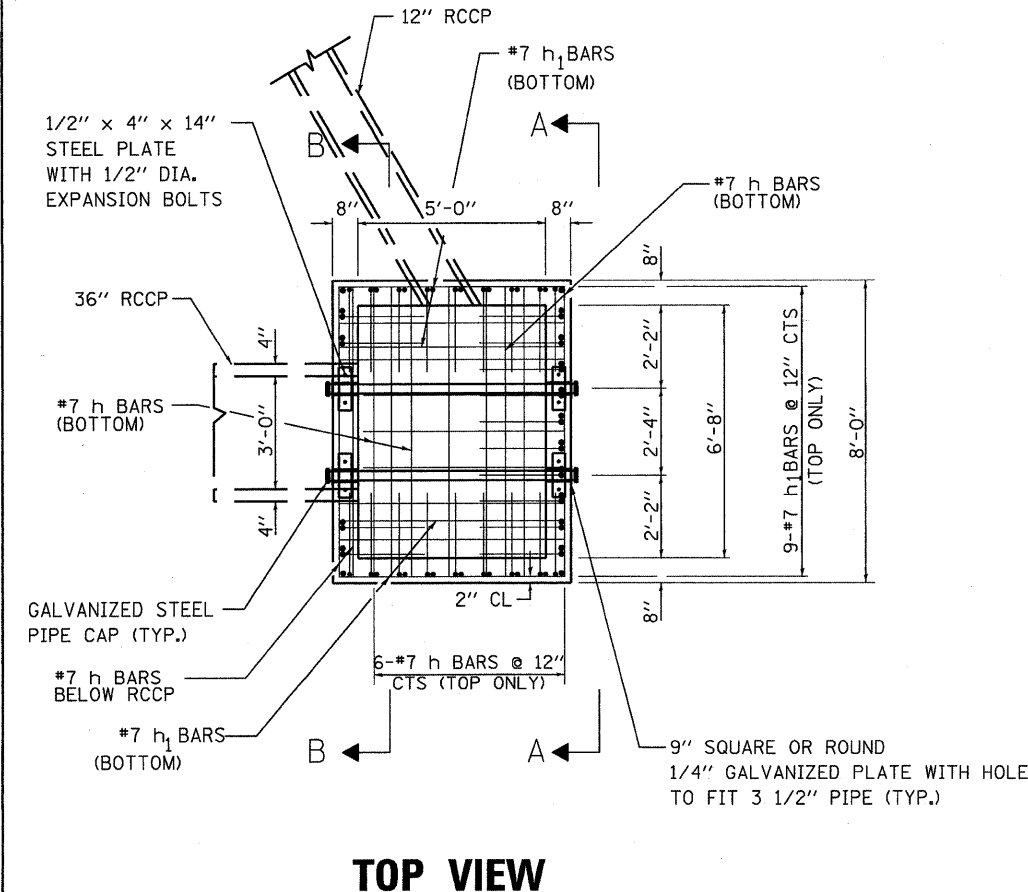

TOP VIEW



David F. Maxwell, S.E.
Reg. No. 081-005455
Date: 3/3/10
My registration expires November 30, 2010.

FILE NAME =	USER NAME =	DESIGNED - GSS	REVISED -	STATE OF ILLINOIS DEPARTMENT OF TRANSPORTATION	DROP BOX NO. 3		F.A.P. RTE. 742	SECTION 37 R-4	COUNTY OGLE	TOTAL SHEETS 867	SHEET NO. 160	
		DRAWN - GSS	REVISED -		SCALE:	SHEET NO. 1 OF 1 SHEETS	STA. TO STA.	FED. ROAD DIST. NO.	ILLINOIS	FED. AID PROJECT	CONTRACT NO. 64E17	
		CHECKED - CTH	REVISED -									
		DATE - 3/2/2010	REVISED -									