

# PAVEMENT MARKING, R.O.W. & EASEMENT

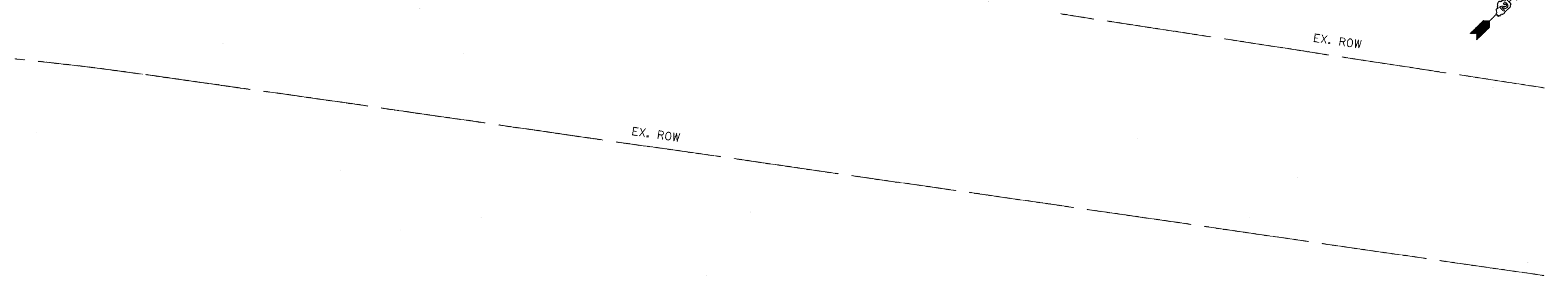

URETHANE PAVEMENT MARKING - LINE 4" (DOUBLE YELLOW) -  
 URETHANE PAVEMENT MARKING - LINE 4" (WHITE) -

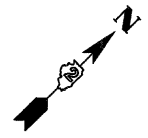
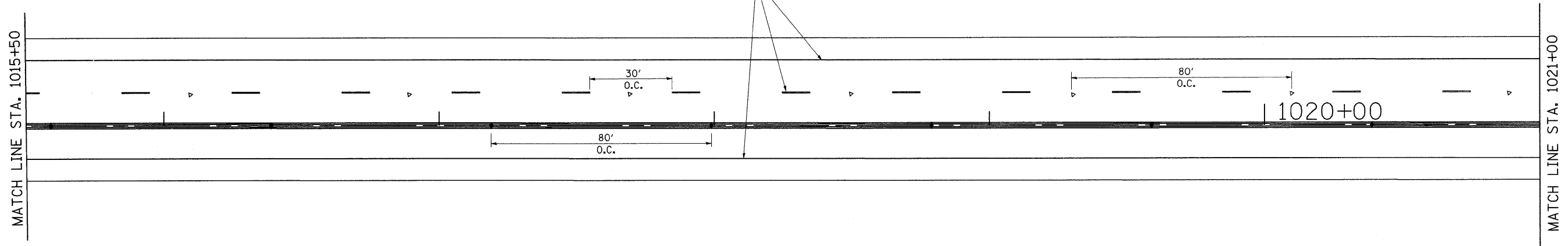

- ◆ TWO-WAY AMBER
- ◁ ONE-WAY CRYSTAL

FILE NAME = c:\pwwork\pwwid\GRANTPM\dms31213\066888pmk.dgn	USER NAME = grantpm	DESIGNED -	REVISED -	<b>STATE OF ILLINOIS DEPARTMENT OF TRANSPORTATION</b>	<b>PAVEMENT MARKING, R.O.W. &amp; EASEMENT</b>	F.A.P RTE. 742	SECTION 37R-4	COUNTY OGLE	TOTAL SHEETS 867	SHEET NO. 401		
PLOT SCALE = 20.0000' / IN.						CONTRACT NO. 64E17						
PLOT DATE = Tue Mar 30 09:40:38 2010						SCALE:      SHEET NO.    OF    SHEETS    STA.                    TO STA.      FED. ROAD DIST. NO.    ILLINOIS FED. AID PROJECT						

# PAVEMENT MARKING, R.O.W. & EASEMENT

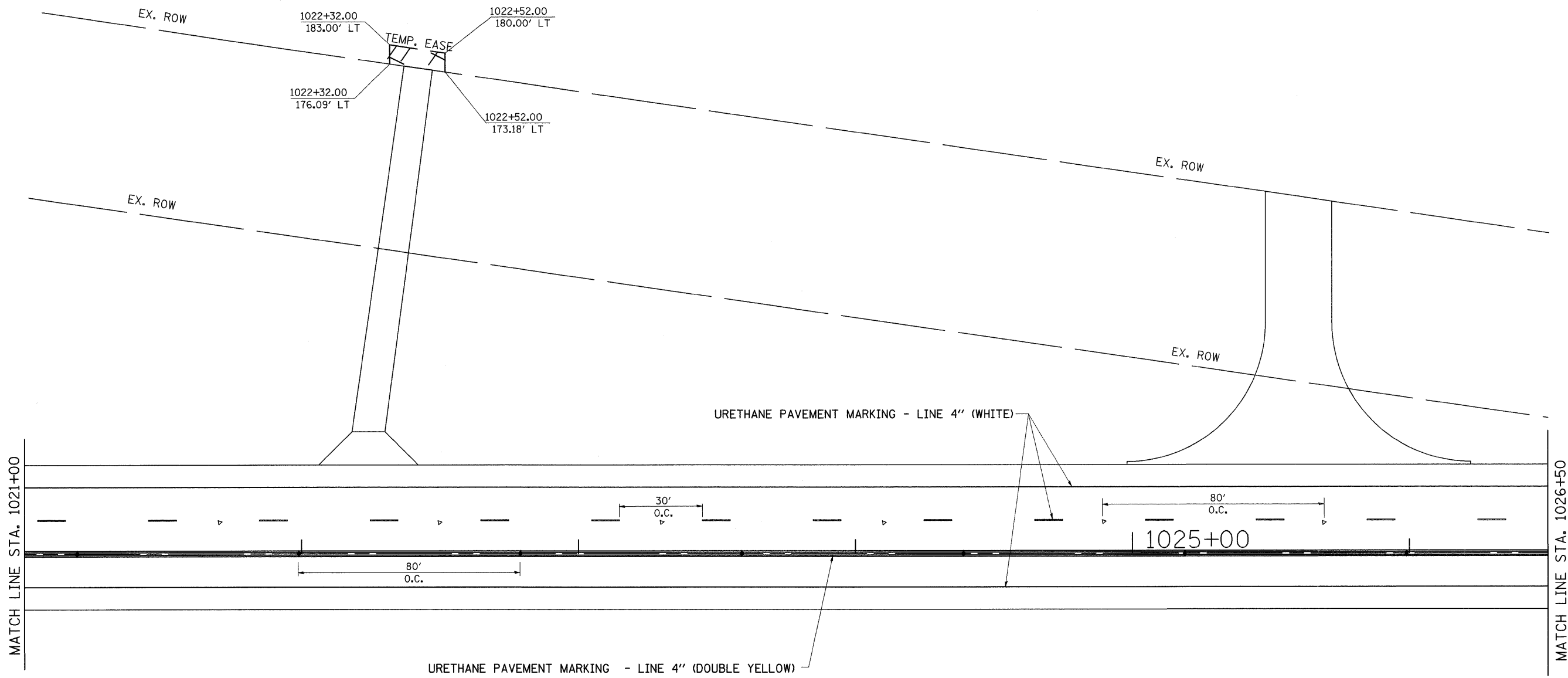
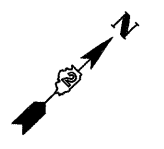

- ◆ TWO-WAY AMBER
- ◁ ONE-WAY CRYSTAL

FILE NAME =	USER NAME = grantpm	DESIGNED -	REVISED -	<b>STATE OF ILLINOIS DEPARTMENT OF TRANSPORTATION</b>	<b>PAVEMENT MARKING, R.O.W. &amp; EASEMENT</b>			F.A.P. RTE.	SECTION	COUNTY	TOTAL SHEETS	SHEET NO.
c:\pw_work\PW\DOT\GRANTPM\dms31213\d06608pmk.dgn		DRAWN -	REVISED -					742	37R-4	OGLE	867	402
		CHECKED -	REVISED -		SCALE:      SHEET NO.    OF    SHEETS    STA.                    TO STA.			FED. ROAD DIST. NO.    ILLINOIS FED. AID PROJECT				
		DATE -	REVISED -		CONTRACT NO. 64E17							

# PAVEMENT MARKING, R.O.W. & EASEMENT

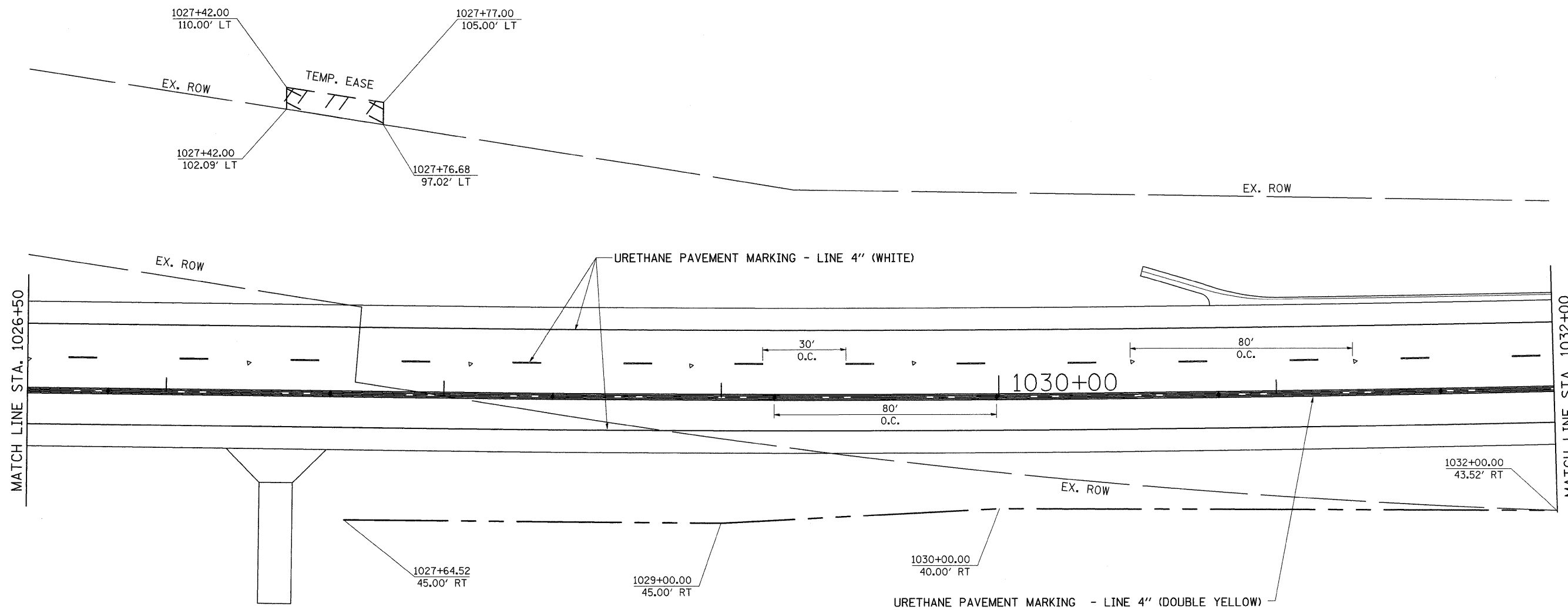
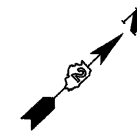

- ◆ TWO-WAY AMBER
- ◁ ONE-WAY CRYSTAL

FILE NAME =	USER NAME = grantpm	DESIGNED -	REVISED -	<b>STATE OF ILLINOIS DEPARTMENT OF TRANSPORTATION</b>	<b>PAVEMENT MARKING, R.O.W. &amp; EASEMENT</b>	F.A.P. RTE.	SECTION	COUNTY	TOTAL SHEETS	SHEET NO.	
cr\pw_work\PWIDOT\GRANTPM\dms31213\d06628pmk.dgn		DRAWN -	REVISED -			742	37R-4	OGLE	867	403	
PLOT SCALE = 20.0000' / IN.		CHECKED -	REVISED -			CONTRACT NO. 64E17					
PLOT DATE = Tue Mar 30 09:40:40 2010		DATE -	REVISED -			SCALE:      SHEET NO.    OF    SHEETS    STA.                    TO STA.      FED. ROAD DIST. NO.    [ILLINOIS] FED. AID PROJECT					

# PAVEMENT MARKING, R.O.W. & EASEMENT

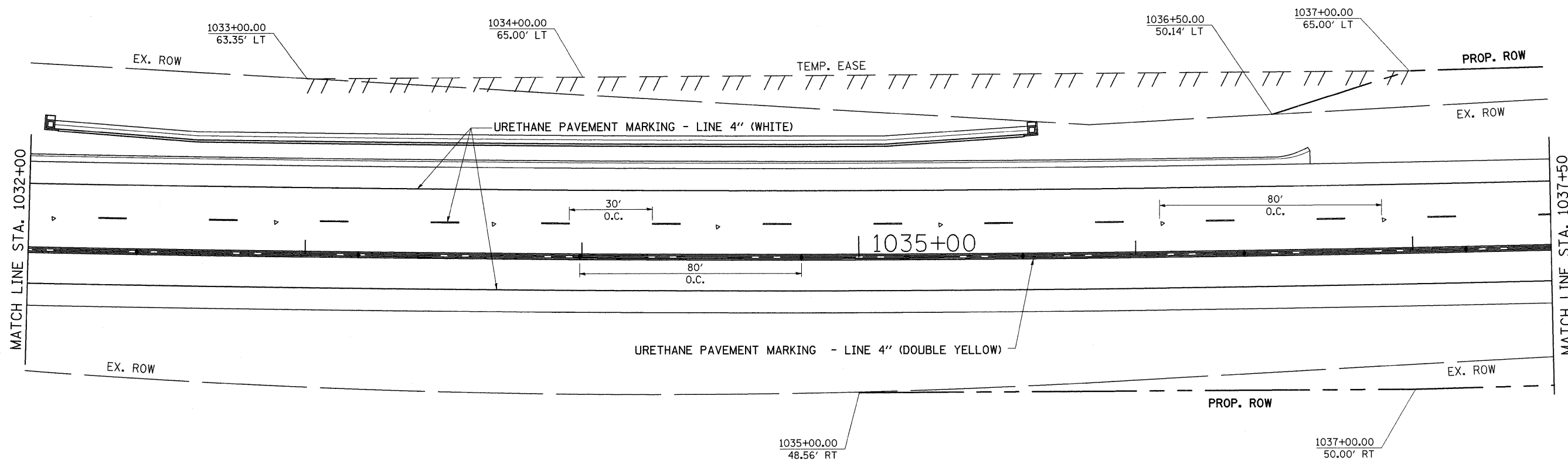
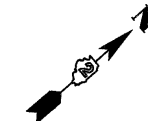

- ◆ TWO-WAY AMBER
- ◁ ONE-WAY CRYSTAL

FILE NAME =	USER NAME = grantpm	DESIGNED -	REVISED -	<b>STATE OF ILLINOIS DEPARTMENT OF TRANSPORTATION</b>	<b>PAVEMENT MARKING, R.O.W. &amp; EASEMENT</b>	F.A.P. RTE.	SECTION	COUNTY	TOTAL SHEETS	SHEET NO.
cr\pw_work\PWIDOT\GRANTPM\dss31213\d06688\pmlk.dgn		DRAWN -	REVISED -			742	37R-4	OGLE	867	404
		CHECKED -	REVISED -			CONTRACT NO. 64E17				
		DATE -	REVISED -			SCALE:	SHEET NO. OF SHEETS	STA. TO STA.	FED. ROAD DIST. NO.	ILLINOIS FED. AID PROJECT

# PAVEMENT MARKING, R.O.W. & EASEMENT

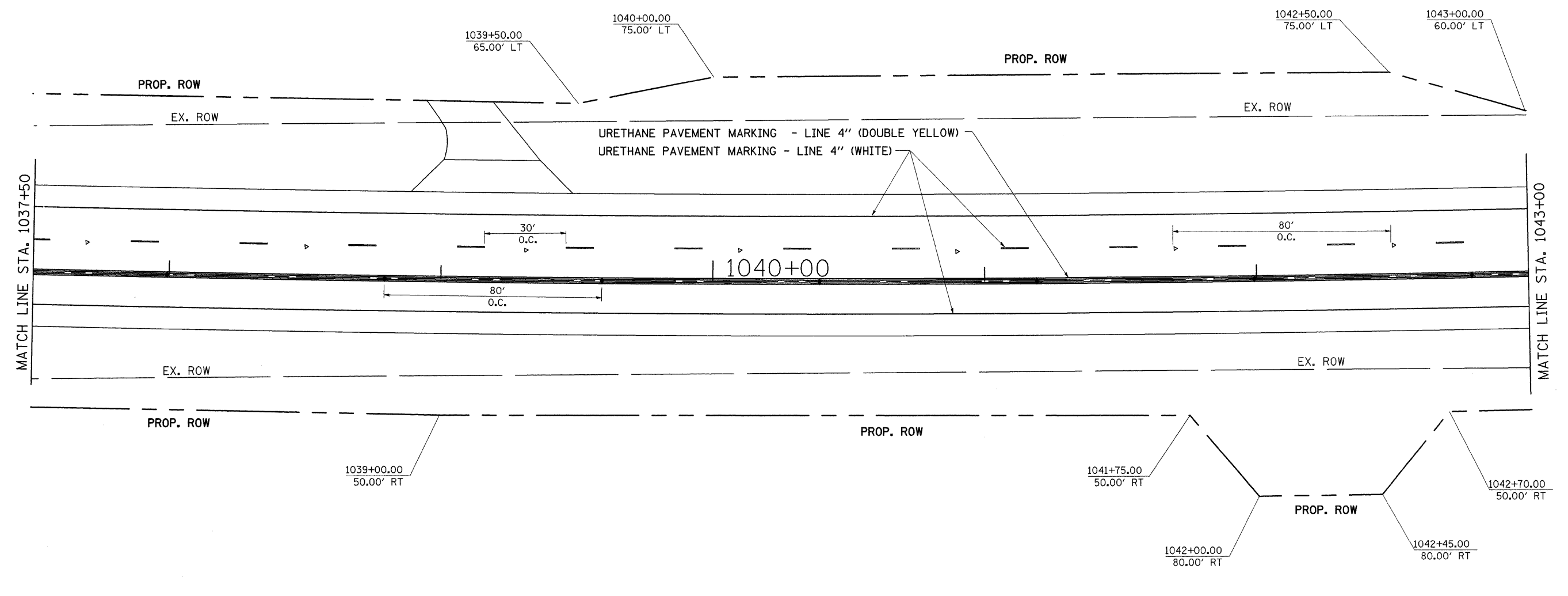
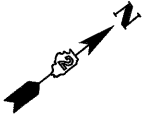

◆ TWO-WAY AMBER  
◁ ONE-WAY CRYSTAL

FILE NAME =	USER NAME = grantpm	DESIGNED -	REVISED -	<b>STATE OF ILLINOIS DEPARTMENT OF TRANSPORTATION</b>	<b>PAVEMENT MARKING, R.O.W. &amp; EASEMENT</b>	F.A.P. RTE.	SECTION	COUNTY	TOTAL SHEETS	SHEET NO.
02\pwork\PWIDOT\GRANTPM\dms31213\006628pmk.dgn	DRAWN -	REVISED -	742			37R-4	OGLE	867	405	
PLOT SCALE = 20.0000' / IN.	CHECKED -	REVISED -	CONTRACT NO. 64E17							
PLOT DATE = Tue Mar 30 09:40:41 2010	DATE -	REVISED -	FED. ROAD DIST. NO. ILLINOIS FED. AID PROJECT							
					SCALE:	SHEET NO. OF SHEETS STA. TO STA.				

# PAVEMENT MARKING, R.O.W. & EASEMENT

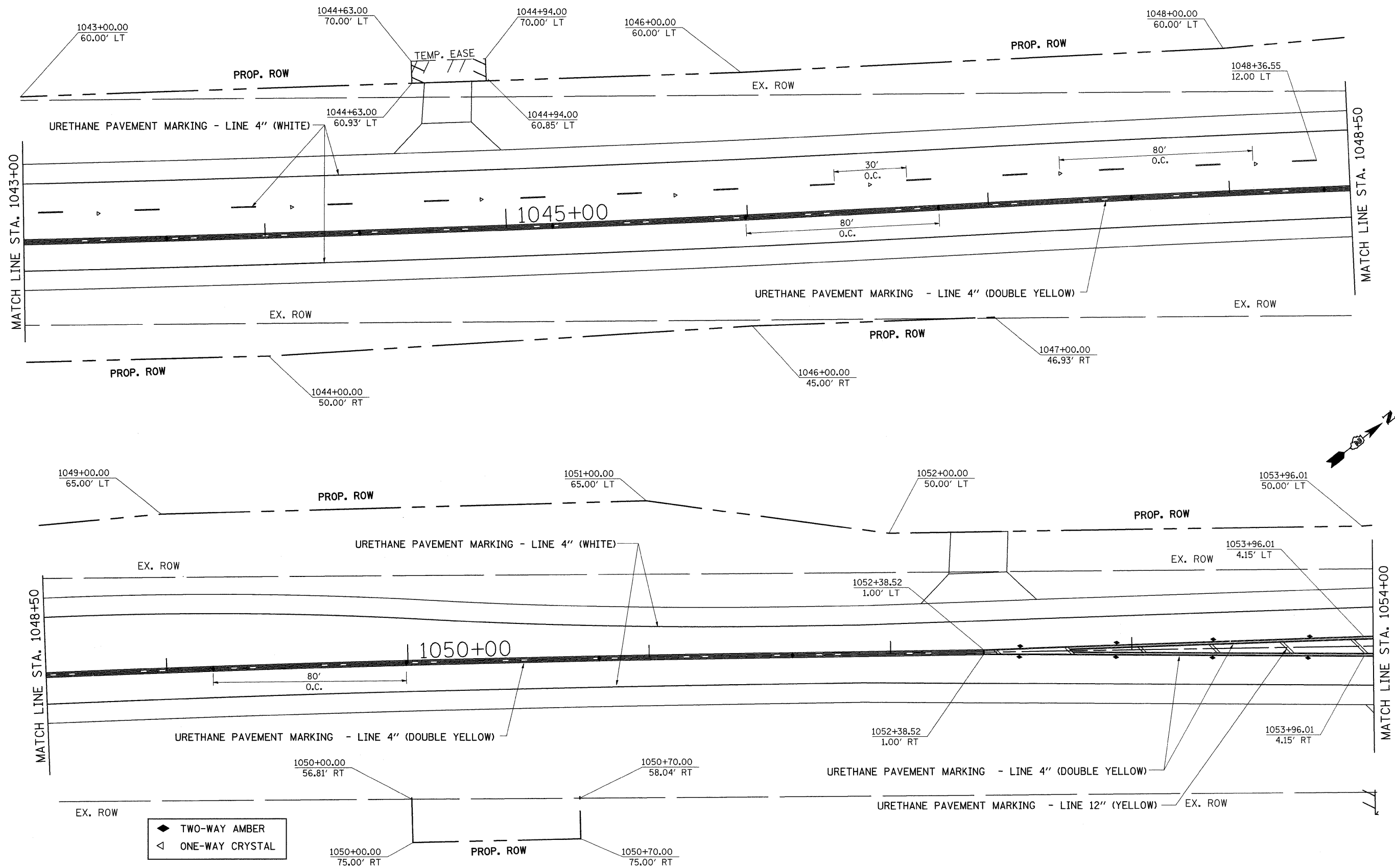
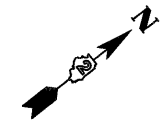

◆ TWO-WAY AMBER  
◁ ONE-WAY CRYSTAL

FILE NAME =	USER NAME = grantpm	DESIGNED -	REVISED -	<b>STATE OF ILLINOIS DEPARTMENT OF TRANSPORTATION</b>	<b>PAVEMENT MARKING, R.O.W. &amp; EASEMENT</b>	F.A.P. RTE.	SECTION	COUNTY	TOTAL SHEETS	SHEET NO.
ct:\pwork\PWIDOT\GRANTPM\dms31213\086888pmk.dgn	PLOT SCALE = 20.0000' / IN.	CHECKED -	REVISED -			742	37R-4	OGLE	867	406
	PLOT DATE = Tue Mar 30 09:40:42 2010	DATE -	REVISED -			SCALE: SHEET NO. OF SHEETS STA. TO STA.		FED. ROAD DIST. NO. ILLINOIS FED. AID PROJECT		
								CONTRACT NO. 64E17		

# PAVEMENT MARKING, R.O.W. & EASEMENT

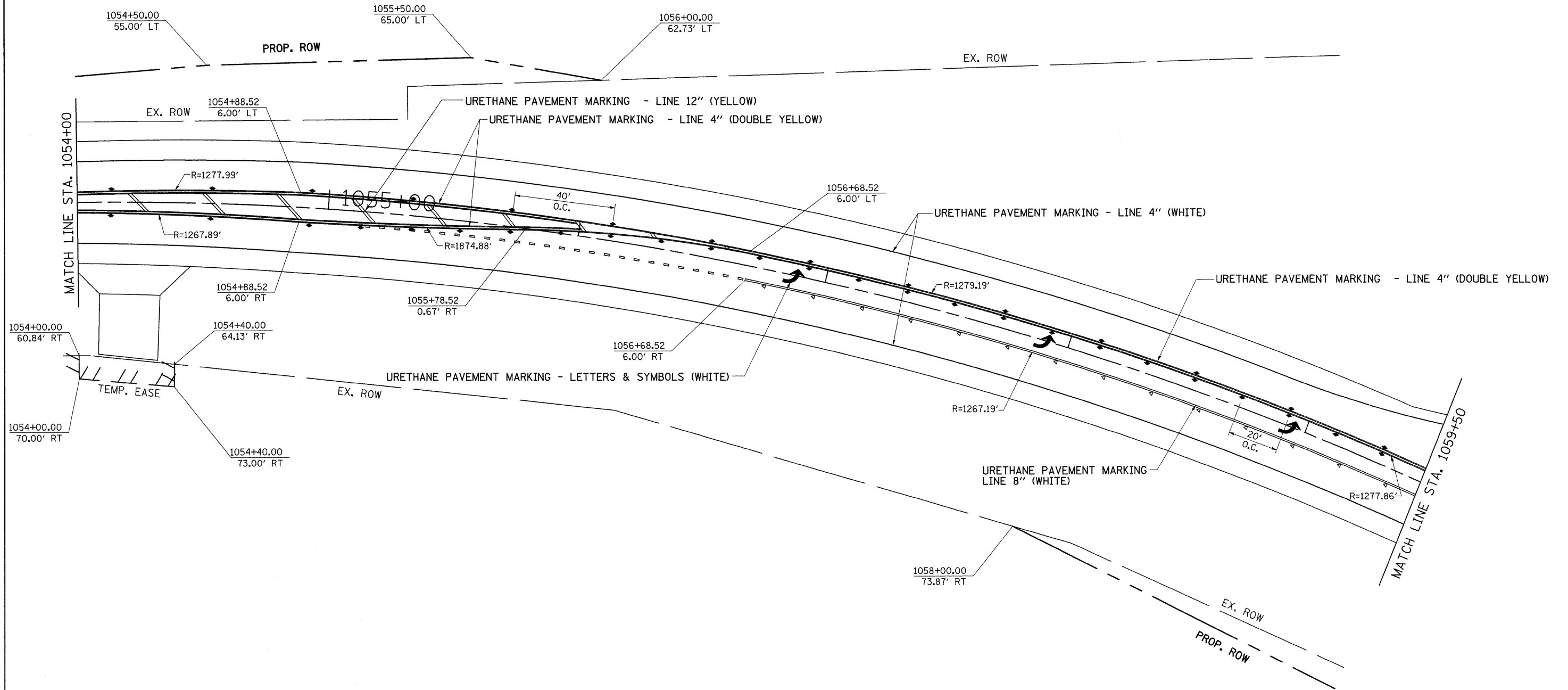
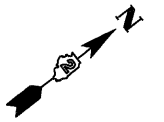

- ◆ TWO-WAY AMBER
- ◁ ONE-WAY CRYSTAL

FILE NAME =	USER NAME = grantpm	DESIGNED -	REVISED -	<b>STATE OF ILLINOIS DEPARTMENT OF TRANSPORTATION</b>	<b>PAVEMENT MARKING, R.O.W. &amp; EASEMENT</b>	F.A.P. RTE.	SECTION	COUNTY	TOTAL SHEETS	SHEET NO.	
cr\pw_work\PWIDOT\GRANTPM\dms31213\dl068088pmk.dgn	PLOT SCALE = 20.0000' / IN.	DRAWN -	REVISED -			742	37R-4	OGLE	867	407	
	PLOT DATE = Tue Mar 30 09:40:42 2010	CHECKED -	REVISED -			CONTRACT NO. 64E17					
		DATE -	REVISED -			SCALE:	SHEET NO.	OF	SHEETS	STA.	TO STA.

# PAVEMENT MARKING, R.O.W. & EASEMENT

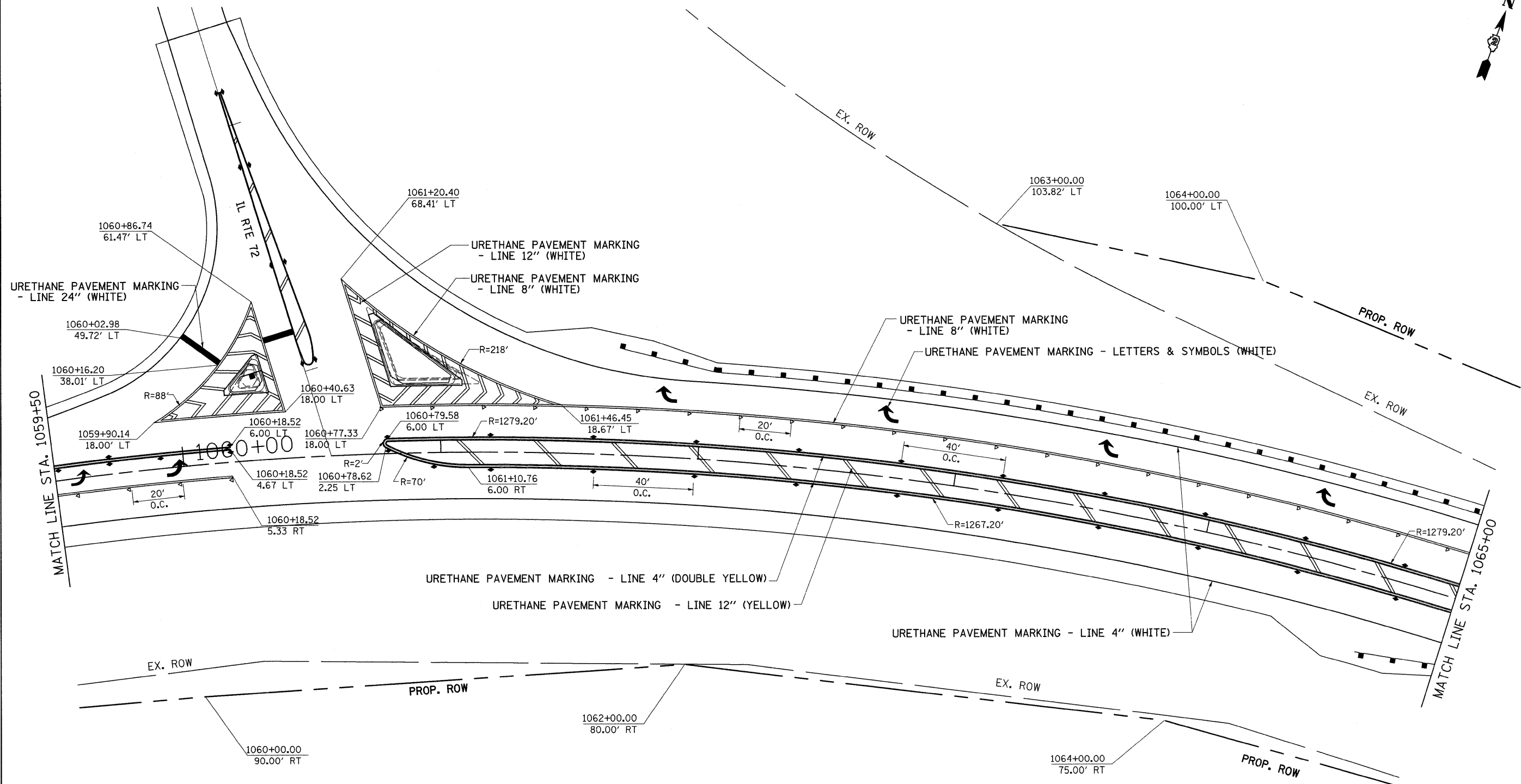

◆ TWO-WAY AMBER  
◁ ONE-WAY CRYSTAL

FILE NAME =	USER NAME = grantpm	DESIGNED -	REVISED -
ca\pw_work\PW\IDOT\GRANTPM\dms31213\1066888\pkm.dgn		DRAWN -	REVISED -
		CHECKED -	REVISED -
		DATE -	REVISED -

STATE OF ILLINOIS  
DEPARTMENT OF TRANSPORTATION

## PAVEMENT MARKING, R.O.W. & EASEMENT

SCALE:	SHEET NO.	OF	SHEETS	STA.	TO STA.
--------	-----------	----	--------	------	---------

F.A.P. RTE. 742	SECTION 37R-4	COUNTY OGLE	TOTAL SHEETS 867	SHEET NO. 408
FED. ROAD DIST. NO.		ILLINOIS FED. AID PROJECT		
		CONTRACT NO. 64E17		



# PAVEMENT MARKING, R.O.W. & EASEMENT

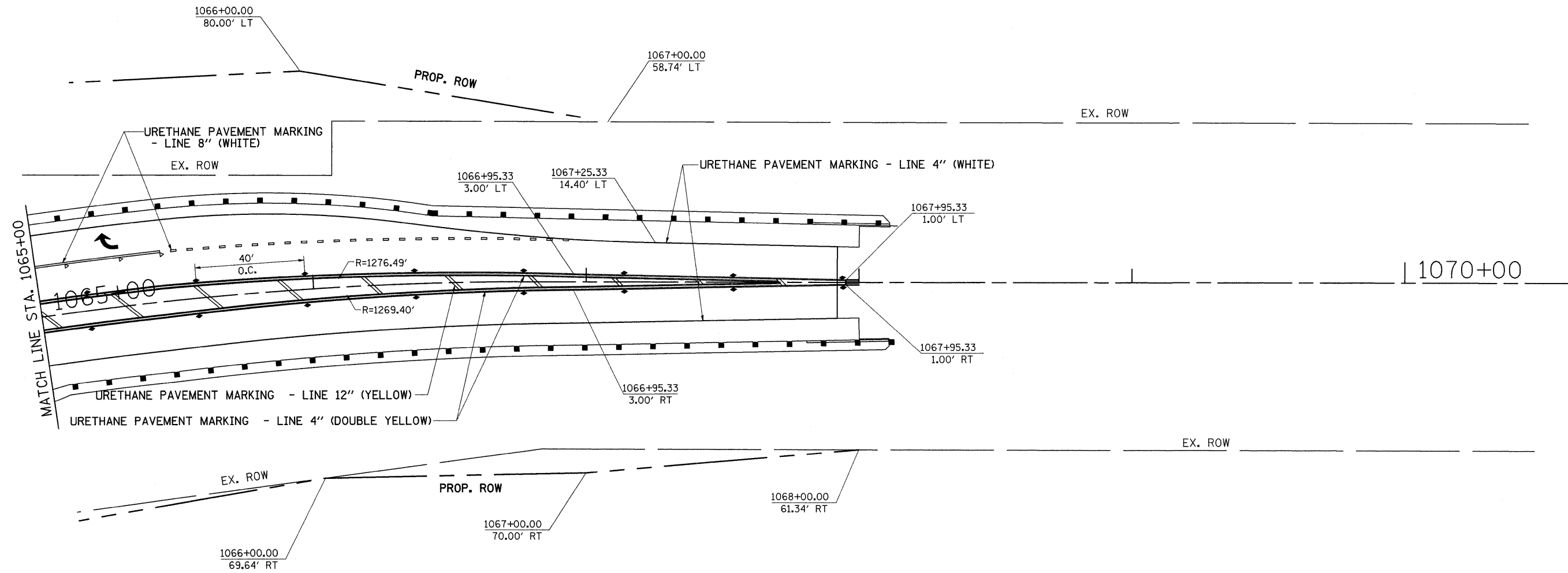

◆ TWO-WAY AMBER  
◁ ONE-WAY CRYSTAL

FILE NAME =	USER NAME = grantpm	DESIGNED -	REVISED -	<b>STATE OF ILLINOIS DEPARTMENT OF TRANSPORTATION</b>	<b>PAVEMENT MARKING, R.O.W. &amp; EASEMENT</b>	F.A.P. RTE.	SECTION	COUNTY	TOTAL SHEETS	SHEET NO.
ct:\pw_work\VP\IDOT\GRANTPM\dms31213\ad868888.pmk.dgn		DRAWN -	REVISED -			742	37R-4	OGL	867	409
		CHECKED -	REVISED -			CONTRACT NO. 64E17				
		DATE -	REVISED -			ILLINOIS FED. AID PROJECT				
PLOT SCALE = 20.0000' / IN.		PLOT DATE = Tue Mar 30 09:40:44 2010		SCALE:		SHEET NO. OF SHEETS STA. TO STA.				

# PAVEMENT MARKING, R.O.W. & EASEMENT

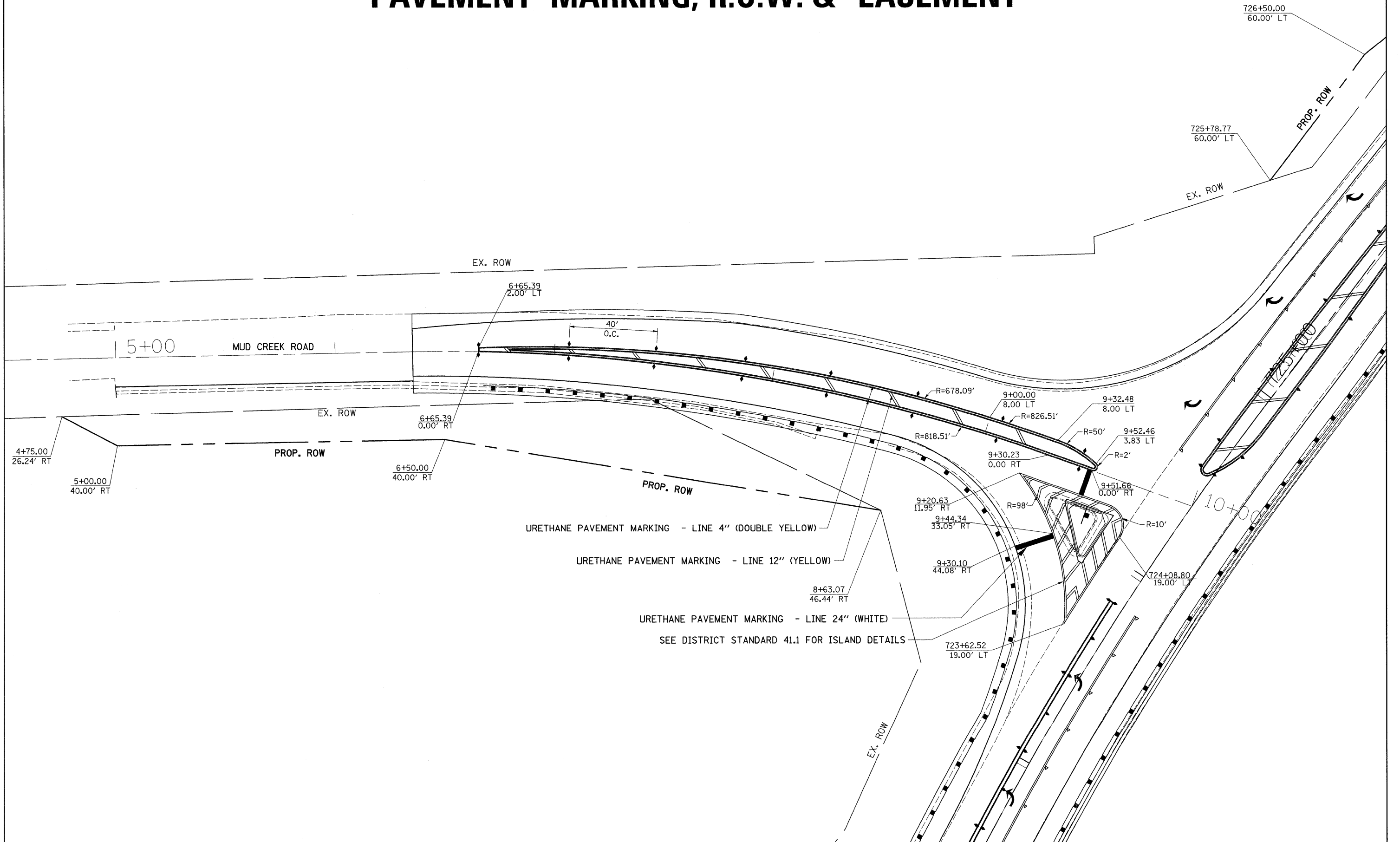

FILE NAME =	USER NAME = grantpm	DESIGNED -	REVISED -	<b>STATE OF ILLINOIS DEPARTMENT OF TRANSPORTATION</b>	<b>PAVEMENT MARKING, R.O.W. &amp; EASEMENT</b>	F.A.P. RTE.	SECTION	COUNTY	TOTAL SHEETS	SHEET NO.
ct\pw_work\PWIDOT\GRANTPM\dms31213\d06628pmk.dgn		DRAWN -	REVISED -			742	37R-4	OGLE	867	410
PLOT SCALE = 20.0000' / IN.		CHECKED -	REVISED -			CONTRACT NO. 64E17				
PLOT DATE = Tue Mar 30 09:40:44 2010		DATE -	REVISED -			FED. ROAD DIST. NO. [ILLINOIS] FED. AID PROJECT				
					SCALE:	SHEET NO. OF SHEETS		STA. TO STA.		

# PAVEMENT MARKING, R.O.W. & EASEMENT

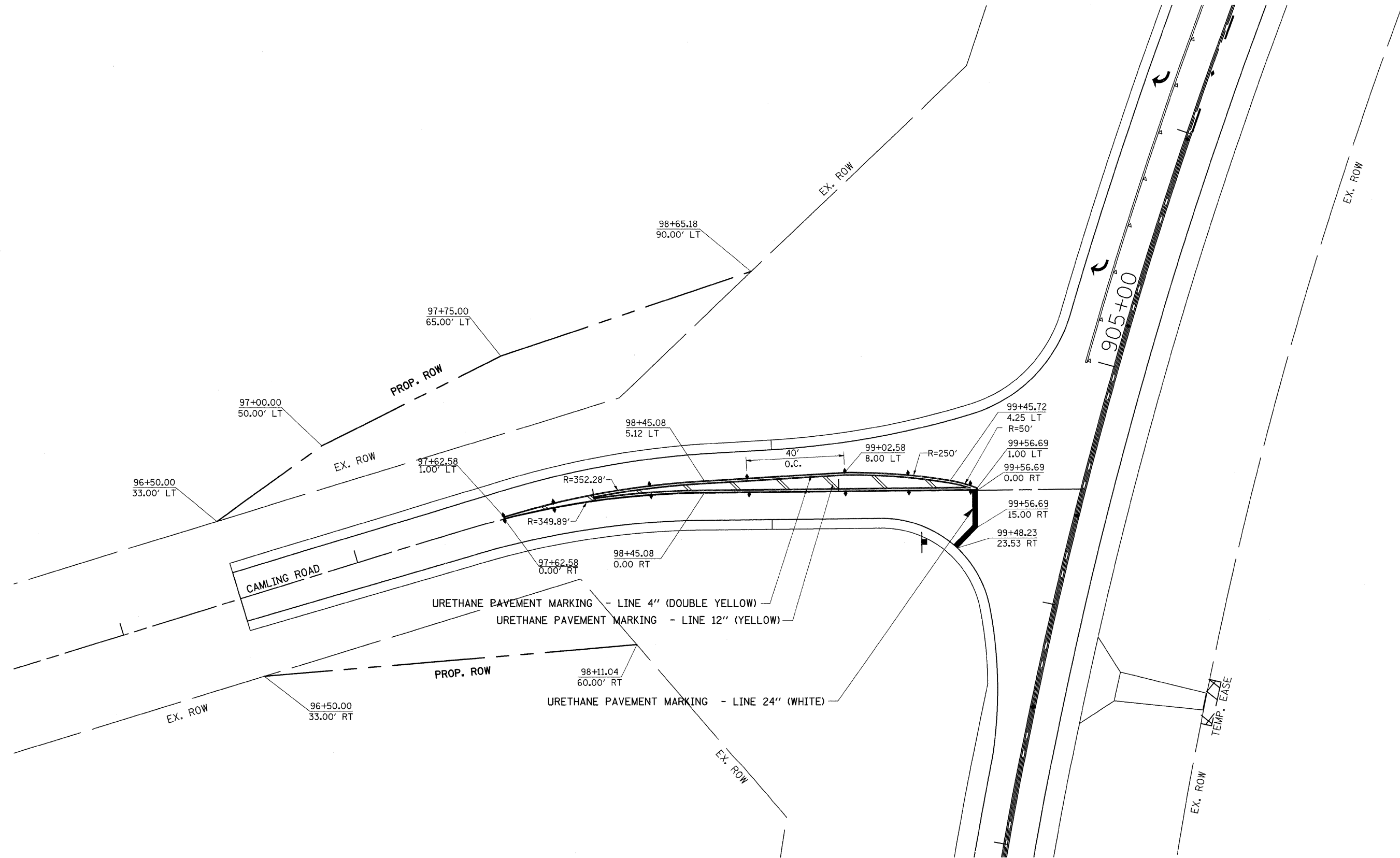

FILE NAME =	USER NAME = grantpm	DESIGNED -	REVISED -	<b>STATE OF ILLINOIS DEPARTMENT OF TRANSPORTATION</b>	<b>PAVEMENT MARKING, R.O.W. &amp; EASEMENT</b>			F.A.P. RTE.	SECTION	COUNTY	TOTAL SHEETS	SHEET NO.
c:\pw_work\PWIDOT\GRANTPM\dms31213\d086808pmk.dgn		DRAWN -	REVISED -					742	37R-4	OGLE	867	411
	PLOT SCALE = 20.0000' / IN.	CHECKED -	REVISED -		SCALE:      SHEET NO.    OF    SHEETS    STA.                    TO STA.			CONTRACT NO. 64E17				
	PLOT DATE = Tue Mar 30 09:40:45 2010	DATE -	REVISED -		FED. ROAD DIST. NO.    ILLINOIS FED. AID PROJECT							

# PAVEMENT MARKING, R.O.W. & EASEMENT

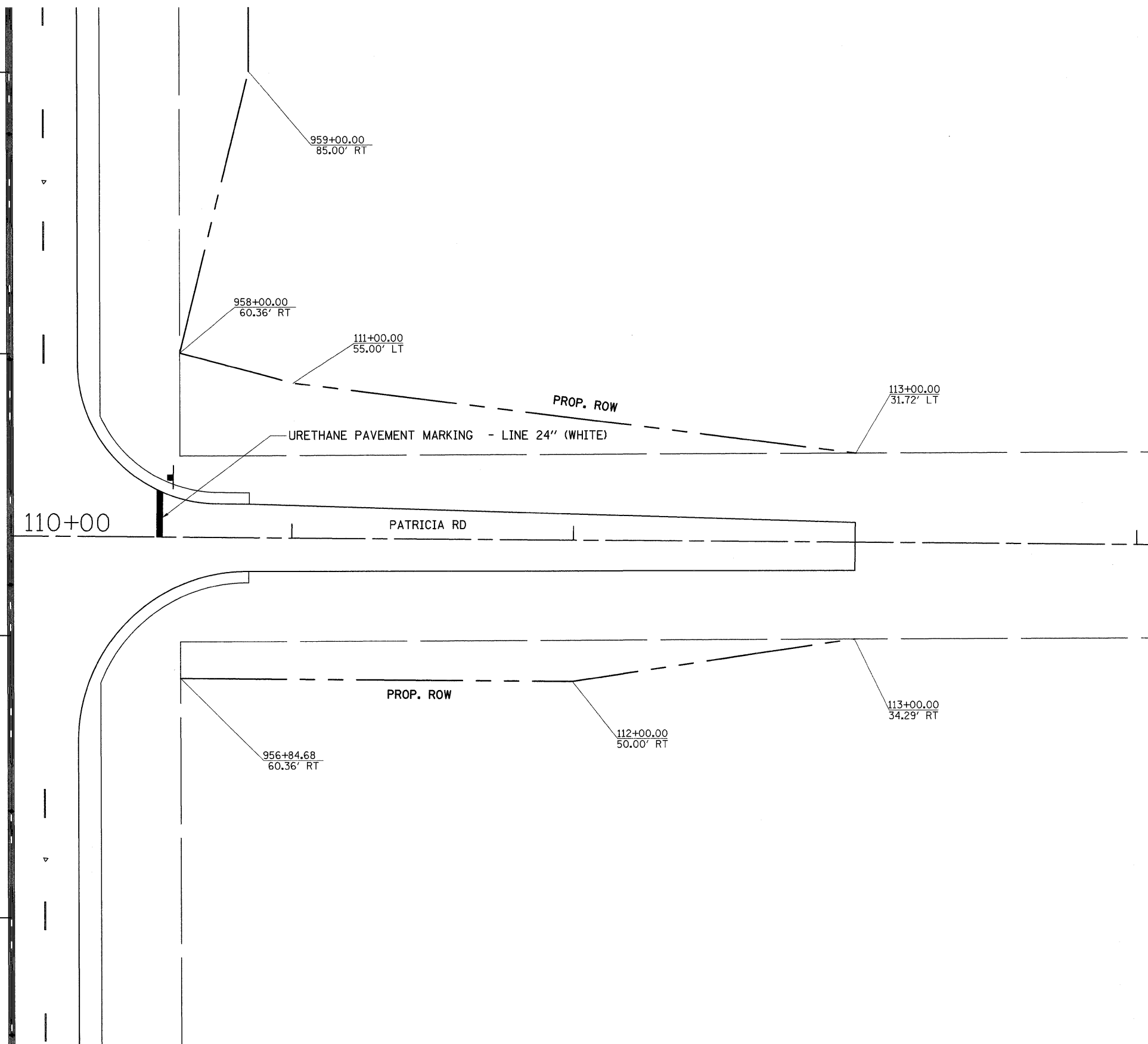

FILE NAME =	USER NAME = grantpm	DESIGNED -	REVISED -	<b>STATE OF ILLINOIS DEPARTMENT OF TRANSPORTATION</b>	<b>PAVEMENT MARKING, R.O.W. &amp; EASEMENT</b>	F.A.P. RTE.	SECTION	COUNTY	TOTAL SHEETS	SHEET NO.
c:\pw_work\PWIDOT\GRANTPM\dms31213\086608pmk.dgn	DRAWN -	REVISED -	742			37R-4	OGLE	867	412	
PLOT SCALE = 20.0000' / IN.	CHECKED -	REVISED -	CONTRACT NO. 64E17							
PLOT DATE = Tue Mar 30 09:40:45 2010	DATE -	REVISED -	SCALE:			SHEET NO. OF SHEETS	STA. TO STA.	FED. ROAD DIST. NO.	ILLINOIS FED. AID PROJECT	



# PAVEMENT MARKING, R.O.W. & EASEMENT

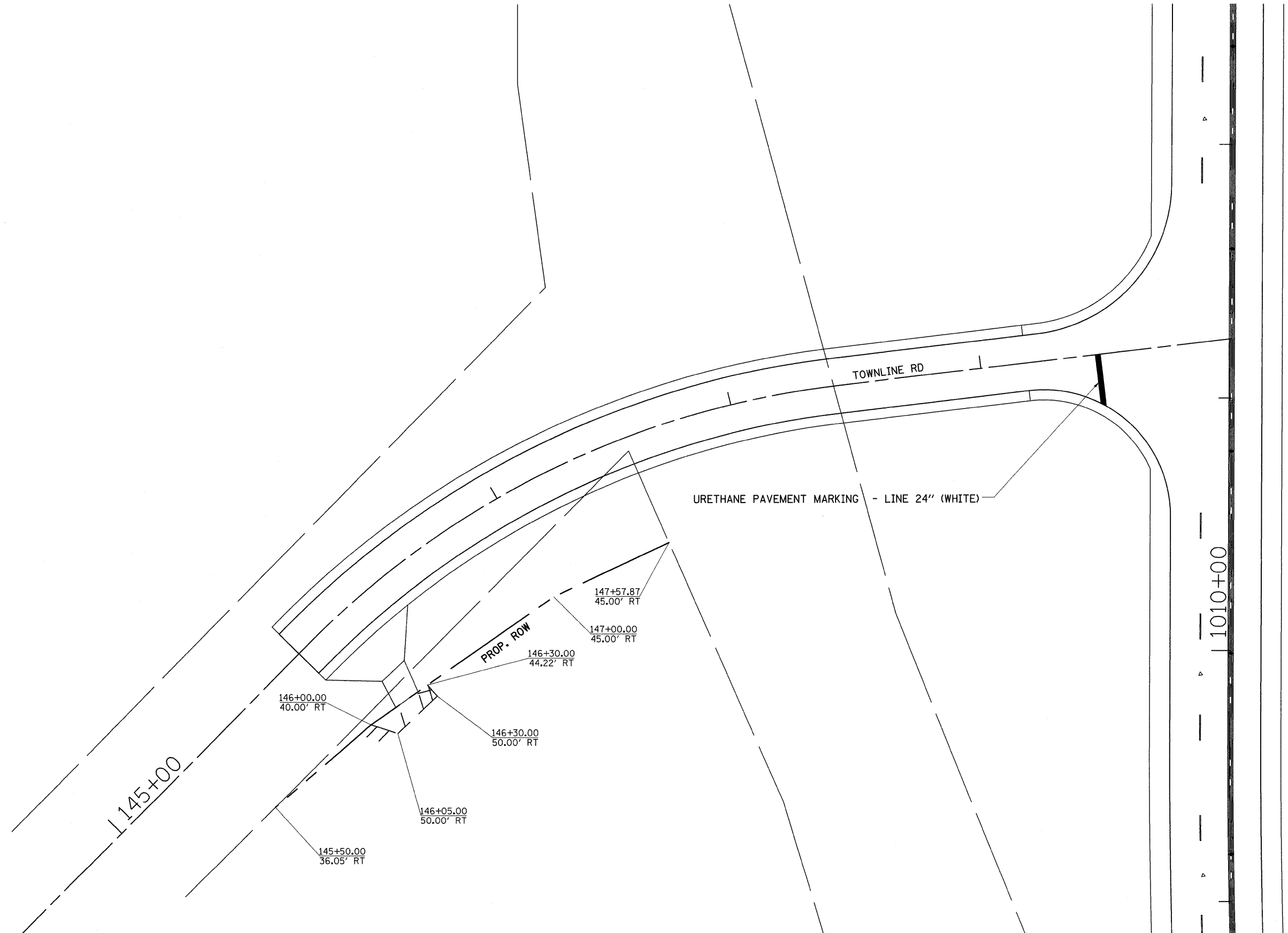

FILE NAME =	USER NAME = grantpm	DESIGNED -	REVISED -	<b>STATE OF ILLINOIS DEPARTMENT OF TRANSPORTATION</b>	<b>PAVEMENT MARKING, R.O.W. &amp; EASEMENT</b>	F.A.P. RTE.	SECTION	COUNTY	TOTAL SHEETS	SHEET NO.	
ca\pw_work\PWIDOT\GRANTPM\dms31213\06698pmk.dgn	PLOT SCALE = 20.0000' / IN.	DRAWN -	REVISED -			742	37R-4	OGLE	867	414	
	PLOT DATE = Tue Mar 30 09:40:46 2010	CHECKED -	REVISED -			SCALE:		SHEET NO. OF SHEETS STA. TO STA.		FED. ROAD DIST. NO. ILLINOIS FED. AID PROJECT	
		DATE -	REVISED -			CONTRACT NO. 64E17					



# BORING LOGS



**Illinois Department of Transportation**  
Division of Highways  
Illinois Department of Transportation/D-2

## ROCK CORE LOG

Page 1 of 1  
Date 4/2/08

ROUTE FA 742 DESCRIPTION P92-064-86 Retaining Wall, IL 2 at Mud Creek Road LOGGED BY W. Garza

SECTION 37 RS-3 LOCATION Rockvale Twp. - 28 NW, SEC., TWP. 24N, RNG. 10E

COUNTY Ogle CORING METHOD \_\_\_\_\_

STRUCT. NO. \_\_\_\_\_ CORING BARREL TYPE & SIZE \_\_\_\_\_  
Station \_\_\_\_\_ Core Diameter 2 in  
BORING NO. B-1d Top of Rock Elev. 74.80 ft  
Station 727+00 Begin Core Elev. 74.30 ft  
Offset 18.00ft Rt CL  
Ground Surface Elev. 99.80 ft

Description	DEPTH (ft)	CORER (#)	RECOVERY (%)	R.Q. (%)	CORE TIME (min/ft)	STRENGTH (tsf)
Dolomite: tan-buff, dense, aphanitic and severely weathered and fractured throughout. No testable segments available.	74.30	1	27	0	1.2	
End of Boring	69.30					

Color pictures of the cores \_\_\_\_\_  
Cores will be stored for examination until \_\_\_\_\_  
The "Strength" column represents the uniaxial compressive strength of the core sample (ASTM D-2938)

BBS, form 138 (Rev. 8-99)



**Illinois Department of Transportation**  
Division of Highways  
Illinois Department of Transportation/D-2

## ROCK CORE LOG

Page 1 of 1  
Date 4/3/08

ROUTE FA 742 DESCRIPTION P92-064-86 Retaining wall, IL 2 at Mud Creek Road LOGGED BY W. Garza

SECTION 37 RS-3 LOCATION Rockvale Twp. - 28NW, SEC., TWP. 24N, RNG. 10E

COUNTY Ogle CORING METHOD \_\_\_\_\_

STRUCT. NO. \_\_\_\_\_ CORING BARREL TYPE & SIZE \_\_\_\_\_  
Station \_\_\_\_\_ Core Diameter 2 in  
BORING NO. B-8d Top of Rock Elev. 85.40 ft  
Station 734+00 Begin Core Elev. 82.90 ft  
Offset 12.00ft Rt CL  
Ground Surface Elev. 99.90 ft

Description	DEPTH (ft)	CORER (#)	RECOVERY (%)	R.Q. (%)	CORE TIME (min/ft)	STRENGTH (tsf)
Dolomite: tan-buff-gray, dense, mostly aphanitic though some calcite crystals visible, moderately bedded. t.s.f.: 82.2 to 81.5 t.s.f.: 79.1 to 78.6 Strength: 616 - 621	82.90	1	100	43		621.0
Dolomite: as above, with some vertical fractures. t.s.f.: 77.4 to 76.9 t.s.f.: 74.3 to 73.5 Strength: 669 - 860	77.90	2	90	30	3.2	860.0
End of Boring	72.90					

Color pictures of the cores \_\_\_\_\_  
Cores will be stored for examination until \_\_\_\_\_  
The "Strength" column represents the uniaxial compressive strength of the core sample (ASTM D-2938)

BBS, form 138 (Rev. 8-99)



# BORING LOGS



**Illinois Department of Transportation**  
Division of Highways  
Illinois Department of Transportation/D-2

## ROCK CORE LOG

Page 1 of 1

Date 4/3/08

ROUTE FA 742 DESCRIPTION P92-064-86 Retaining wall, IL 2 at Mud Creek Road LOGGED BY Be. Wetzell

SECTION 37 RS-3 LOCATION Rockvale Twp. - 28 NW, SEC. , TWP. 24N, RNG. 10E

COUNTY Ogle CORING METHOD \_\_\_\_\_

STRUCT. NO. \_\_\_\_\_ CORING BARREL TYPE & SIZE \_\_\_\_\_  
Station \_\_\_\_\_  
BORING NO. B-15d Core Diameter 2 in  
Station 741+00 Top of Rock Elev. 82.90 ft  
Offset 12.00ft Rt CL Begin Core Elev. 70.90 ft  
Ground Surface Elev. 99.90 ft

DESCRIPTION	ELEV. (ft)	DEPTH (#)	RECOVERY (%)	R-Q (%)	CORE TIME (min/ft)	STRENGTH (tsf)
Dolomite: buff-tan, dense, aphanitic, severely weathered and fractured throughout.	70.90	1	40	0	5.4	
	-30					
	65.90	2	40	0	4	
Dolomite: As above.						
	-35					
	60.90					
End of Boring						
	-40					
	-45					

Color pictures of the cores \_\_\_\_\_  
Cores will be stored for examination until \_\_\_\_\_  
The "Strength" column represents the uniaxial compressive strength of the core sample (ASTM D-2938)

BBS, form 138 (Rev. 8-99)

FILE NAME =	USER NAME = grantpm	DESIGNED -	REVISED -
cs:\pw_work\PWIDOT\GRANTPM\dms31213\0806281logs.dgn		DRAWN -	REVISED -
	PLOT SCALE = 1/8" = 1' IN.	CHECKED -	REVISED -
	PLOT DATE = Tue Mar 30 09:31:23 2010	DATE -	REVISED -

**STATE OF ILLINOIS  
DEPARTMENT OF TRANSPORTATION**

## BORING LOGS

F.A.P. RTE. 742	SECTION 37R-4	COUNTY OGLE	TOTAL SHEETS 867	SHEET NO. 417
SCALE:		SHEET NO. OF SHEETS	STA. TO STA.	FED. ROAD DIST. NO. [ILLINOIS] FED. AID PROJECT
			CONTRACT NO. 64E17	

# BORING LOGS



Illinois Department of Transportation  
Division of Highways  
Illinois Department of Transportation/D-2

## SOIL BORING LOG

Page 1 of 1

Date 11/30/07

ROUTE FA 742 DESCRIPTION P92-064-86 IL 2 culvert, 1.7 m. S. of Byron LOGGED BY W. Garza

SECTION 37 RS-3 LOCATION Rockvale Twp. - 2 SE, SEC., TWP. 24N, RNG. 10E

COUNTY Ogle DRILLING METHOD Hollow Stem Auger HAMMER TYPE B-53 Diedrich Automatic

STRUCT. NO. Station	962+86	D E P T H  H	B L O W S  S	U C S  Qu	M O I S T  T	Surface Water Elev.	_____ ft
BORING NO. Station	B-2g 962+75					Stream Bed Elev.	96.50 ft
Offset	38.00ft Rt CL					Groundwater Elev.:	_____ ft
Ground Surface Elev.	97.50 ft					First Encounter	_____ ft
						Upon Completion	_____ ft
			After _____ Hrs.	_____ ft			

	(ft)	(/6")	(tsf)	(%)
MEDIUM brown LOAM			0.9 P	14.0
	95.00			
MEDIUM brown SANDY LOAM		3		
		4	0.5 P	15.0
	93.00			
MEDIUM tan clean SANDY GRAVEL		4		
		6		
	91.00		8	
	88.50			
DENSE tan clean medium coarse SAND		11		
		14		
	86.00		17	
	83.50			
DENSE tan clean dry SAND & GRAVEL		10		
		16		
	81.00		25	
MEDIUM tan clean dry medium SAND		9		
		9		
	78.50		10	
End of Boring				
				-20

The Unconfined Compressive Strength (UCS) Failure Mode is indicated by (B-Bulge, S-Shear, P-Penetrometer)  
The SPT (N value) is the sum of the last two blow values in each sampling zone (AASHTO T206)

BBS, from 137 (Rev. 8-99)

FILE NAME =	USER NAME = grantpm	DESIGNED -	REVISED -	<b>STATE OF ILLINOIS DEPARTMENT OF TRANSPORTATION</b>	<b>BORING LOGS</b>	F.A.P. RTE. 742	SECTION 37R-4	COUNTY OGLE	TOTAL SHEETS 867	SHEET NO. 418	
ca\pw_work\PWIDOT\GRANTPM\dms31213\d06681logs.dgn		DRAWN -	REVISED -			SCALE:	SHEET NO. OF SHEETS	STA. TO STA.	FED. ROAD DIST. NO.	ILLINOIS FED. AID PROJECT	
		CHECKED -	REVISED -							CONTRACT NO. 64E17	
		DATE -	REVISED -								

# BORING LOGS



**Illinois Department of Transportation**  
Division of Highways  
Illinois Department of Transportation/D-2

## SOIL BORING LOG

Page 1 of 1  
Date 5/8/08

ROUTE FA 742 DESCRIPTION P92-064-86 Retaining wall along Route 2, from a point 950' S. of Mud Creek Road LOGGED BY W. Garza

SECTION 37 RS-3 LOCATION Rockvale Twp. - 28 NW, SEC. , TWP. 24N, RNG. 10E

COUNTY Ogle DRILLING METHOD Hollow Stem Auger HAMMER TYPE CME-45 Automatic

STRUCT. NO. Station	D E P T H S	B L O W S	U C S Qu	M O I S T S	Surface Water Elev.		D E P T H S	B L O W S	U C S Qu	M O I S T S
					ft	ft				
BORING NO. <u>B-1c</u> Station <u>710+19</u> Offset <u>12.00ft Rt CL</u> Ground Surface Elev. <u>679.40</u> ft	(ft)	(/6")	(tsf)	(%)			(ft)	(/6")	(tsf)	(%)
MEDIUM brown LOAM			0.6 P	18.0						
MEDIUM brown LOAM with LIMESTONE fragments	677.40	2								
	675.90	3	0.8 P	11.0						
LOOSE tan moist weathered LIMESTONE	673.40	5								
LOOSE tan/brown weathered LIMESTONE	670.90	4								
LOOSE tan weathered LIMESTONE	668.40	3								
MEDIUM tan dry weathered LIMESTONE	665.90	13								
VERY DENSE tan weathered LIMESTONE	663.40	70								
VERY DENSE tan weathered LIMESTONE	660.90	100/9"								
Auger Refusal	660.90									

Run 1  
Box #7  
Time: 18 minutes  
POOR tan LIMESTONE  
60% Recovery  
0" RQD (continued)

Box #7  
Time: 14 minutes  
POOR tan weathered LIMESTONE  
60% Recovery

End of Boring

The Unconfined Compressive Strength (UCS) Failure Mode is indicated by (B-Bulge, S-Shear, P-Penetrometer)  
The SPT (N value) is the sum of the last two blow values in each sampling zone (AASHTO T206)

BBS, from 137 (Rev. 8-99)



**Illinois Department of Transportation**  
Division of Highways  
Illinois Department of Transportation/D-2

## SOIL BORING LOG

Page 1 of 1  
Date 5/8/08

ROUTE FA 742 DESCRIPTION P92-064-86 Retaining wall along Route 2, from a point 950' S. of Mud Creek LOGGED BY W. Garza

SECTION 37 RS-3 LOCATION Rockvale Twp. - 28 NW, SEC. , TWP. 24N, RNG. 10E

COUNTY Ogle DRILLING METHOD Hollow Stem Auger HAMMER TYPE CME-45 Automatic

STRUCT. NO. Station	D E P T H S	B L O W S	U C S Qu	M O I S T S	Surface Water Elev.		D E P T H S	B L O W S	U C S Qu	M O I S T S
					ft	ft				
BORING NO. <u>B-2c</u> Station <u>711+00</u> Offset <u>13.00ft Rt CL</u> Ground Surface Elev. <u>679.40</u> ft	(ft)	(/6")	(tsf)	(%)			(ft)	(/6")	(tsf)	(%)
Shoulder Rock										
MEDIUM brown SILTY CLAY LOAM with LIMESTONE fragments	677.40	2								
	675.90	4	0.7 P	21.0						
MEDIUM brown LOAM with LIMESTONE fragments	673.40	7	0.6 P	27.0						
LOOSE tan/brown weathered LIMESTONE	670.90	4								
MEDIUM tan weathered LIMESTONE	668.40	9								
LOOSE tan weathered LIMESTONE	665.90	4								
VERY DENSE tan weathered LIMESTONE	663.40	100/2"								
Auger Refusal	663.40									
End of Boring										

The Unconfined Compressive Strength (UCS) Failure Mode is indicated by (B-Bulge, S-Shear, P-Penetrometer)  
The SPT (N value) is the sum of the last two blow values in each sampling zone (AASHTO T206)

BBS, from 137 (Rev. 8-99)

# BORING LOGS



**Illinois Department of Transportation**  
Division of Highways  
Illinois Department of Transportation/D-2

## SOIL BORING LOG

Page 1 of 1  
Date 5/8/08

ROUTE FA 742 DESCRIPTION P92-064-86 Retaining wall along Route 2, from a point 950' S. of Mud Creek LOGGED BY W. Garza

SECTION 37 RS-3 LOCATION Rockvale Twp. - 28 NW, SEC. , TWP. 24N, RNG. 10E

COUNTY Ogle DRILLING METHOD Hollow Stem Auger HAMMER TYPE CME-45 Automatic

STRUCT. NO. Station	D E P T H	B L O W S	U C S	M O D E	Surface Water Elev.	
					ft	ft
BORING NO. <u>B-3c</u> Station <u>712+00</u> Offset <u>13.00ft Rt CL</u> Ground Surface Elev. <u>679.60</u> ft	(ft)	(/6")	(tsf)	(%)	Groundwater Elev.:	
					First Encounter	<u>667.6</u> ft ▼
					Upon Completion	<u>670.1</u> ft ▼
					After	<u>    </u> Hrs. ft
STIFF brown LOAM			1.0 P	17.0		
MEDIUM tan weathered LIMESTONE	677.60	6				
	676.10	8				
MEDIUM/SOFT tan/brown weathered LIMESTONE with bottom 6" LOAM		18				
	673.60	4	0.3 P	26.0		
MEDIUM dark brown LOAM with 9% ORGANICS		1				
	670.60	2	0.6 P	42.0		
		3				
MEDIUM tan weathered LIMESTONE		9				
	668.60	6				
		8				
DENSE tan weathered LIMESTONE		14				
	666.10	21				
		23				
VERY DENSE tan weathered LIMESTONE		100/2"				
Auger Refusal at 15' End of Boring	663.60					

The Unconfined Compressive Strength (UCS) Failure Mode is indicated by (B-Bulge, S-Shear, P-Penetrometer)  
The SPT (N value) is the sum of the last two blow values in each sampling zone (AASHTO T206)

BBS, from 137 (Rev. 8-99)



**Illinois Department of Transportation**  
Division of Highways  
Illinois Department of Transportation/D-2

## SOIL BORING LOG

Page 1 of 1  
Date 5/8/08

ROUTE FA 742 DESCRIPTION P92-064-86 Retaining wall along Route 2, from a point 950' S. of Mud Creek Road LOGGED BY W. Garza

SECTION 37 RS-3 LOCATION Rockvale Twp. - 28NW, SEC. , TWP. 24N, RNG. 10E

COUNTY Ogle DRILLING METHOD Hollow Stem Auger HAMMER TYPE CME-45 Automatic

STRUCT. NO. Station	D E P T H	B L O W S	U C S	M O D E	Surface Water Elev.	
					ft	ft
BORING NO. <u>B-4c</u> Station <u>713+00</u> Offset <u>17.00ft Rt E CL</u> Ground Surface Elev. <u>680.00</u> ft	(ft)	(/6")	(tsf)	(%)	Groundwater Elev.:	
					First Encounter	<u>668.0</u> ft ▼
					Upon Completion	<u>672.0</u> ft ▼
					After	<u>    </u> Hrs. ft
Shoulder Rock						
	678.00	9				
SOFT brown SILTY CLAY LOAM with LIMESTONE fragments		12	0.3 P	32.0		
	676.50	3				
VERY SOFT light brown LOAM		2				
	674.00	1	0.2 P	31.0		
		2				
SOFT dark green LOAM		2				
	671.50	2	0.4 P	34.0		
		2				
SOFT brown LOAM		1				
	668.50	2	0.4 B	27.0		
		6				
VERY DENSE tan weathered LIMESTONE		5				
	666.50	37				
		20				
VERY DENSE tan weathered LIMESTONE		35				
	664.00	34				
Auger Refusal - 83.1 End of Boring		23				

The Unconfined Compressive Strength (UCS) Failure Mode is indicated by (B-Bulge, S-Shear, P-Penetrometer)  
The SPT (N value) is the sum of the last two blow values in each sampling zone (AASHTO T206)

BBS, from 137 (Rev. 8-99)

# BORING LOGS



**Illinois Department of Transportation**  
Division of Highways  
Illinois Department of Transportation/D-2

## SOIL BORING LOG

Page 1 of 1  
Date 5/12/08

ROUTE FA 742 DESCRIPTION P92-064-86 Retaining wall along Route 2 from a point 950' S. of Mud Creek Road LOGGED BY W. Garza

SECTION 37 RS-3 LOCATION Rockvale Twp. - 28NW, SEC. , TWP. 24N, RNG. 10E

COUNTY Ogle DRILLING METHOD Hollow Stem Auger HAMMER TYPE CME-45 Automatic

STRUCT. NO. Station	D E P T H ft	B L O W S (/6")	U C S (tsf)	M O I S T (%)	Surface Water Elev.		D E P T H ft	B L O W S (/6")	U C S (tsf)	M O I S T (%)
					93.50	ft				
BORING NO. <u>B-11c</u> Station <u>715+00</u> Offset <u>17.00ft Rt CL</u> Ground Surface Elev. <u>681.70</u> ft					Groundwater Elev.:					
					First Encounter	<u>669.7</u> ft				
					Upon Completion	<u>674.2</u> ft				
					After Hrs.					
					VERY DENSE tan weathered LIMESTONE (continued)					
					End of Boring	<u>660.70</u>				
STIFF tan SILTY LOAM	679.70	3								
		2	1.1	21.0						
	678.20	4	P							
MEDIUM dark gray SILTY CLAY LOAM		2								
		3	0.5	32.0						
	675.70	2	P							
STIFF dark gray SILTY LOAM		1								
		2	1.0	38.0						
	673.20	4	B							
MEDIUM dark gray LOAM		2								
		2	0.6	31.0						
	670.70	4	B							
MEDIUM tan LOAM with weathered LIMESTONE fragments		1								
		2	0.9	23.0						
	667.70	5	P							
VERY DENSE tan weathered LIMESTONE		5								
		100/11"								
	665.70									
VERY DENSE tan weathered LIMESTONE		100/9"								
	663.20									
		100/1"								

The Unconfined Compressive Strength (UCS) Failure Mode is indicated by (B-Bulge, S-Shear, P-Penetrometer)  
The SPT (N value) is the sum of the last two blow values in each sampling zone (AASHTO T206)

BBS, from 137 (Rev. 8-99)



**Illinois Department of Transportation**  
Division of Highways  
Illinois Department of Transportation/D-2

## SOIL BORING LOG

Page 1 of 1  
Date 4/2/08

ROUTE FA 742 DESCRIPTION P92-064-86 Retaining Wall, IL 2 at Mud Creek Road LOGGED BY W. Garza

SECTION 37 RS-3 LOCATION Rockvale Twp. - 28 NW, SEC. , TWP. 24N, RNG. 10E

COUNTY Ogle DRILLING METHOD Hollow Stem Auger HAMMER TYPE B-53 Diedrich Automatic

STRUCT. NO. Station	D E P T H ft	B L O W S (/6")	U C S (tsf)	M O I S T (%)	Surface Water Elev.		D E P T H ft	B L O W S (/6")	U C S (tsf)	M O I S T (%)
					91.90	ft				
BORING NO. <u>B-1d</u> Station <u>727+00</u> Offset <u>18.00ft Rt CL</u> Ground Surface Elev. <u>99.80</u> ft					Groundwater Elev.:					
					First Encounter	<u>84.8</u> ft				
					Upon Completion					
					After Hrs.					
Shoulder					MEDIUM tan weathered LIMESTONE with SAND lens					
	97.30	3								
STIFF brown SILTY CLAY LOAM		4	1.8	23.0						
		6	P							
	95.80				MEDIUM tan fine SAND with SILTY CLAY lens					
	95.80	6	P							
STIFF gray SILTY CLAY LOAM		2								
		2	1.3	21.0						
	93.30	4	P		VERY DENSE tan weathered LIMESTONE					
					Auger Refusal at 25.5'					
					Borehole continued with rock coring.					
SOFT dark gray SILTY LOAM		2								
		2	0.3	33.0						
	90.80	3	B							
MEDIUM dark gray SILTY CLAY LOAM		3								
		4	0.5	20.0						
	88.30	5	P							
MEDIUM dark gray SILTY CLAY LOAM		2								
		3	0.5	23.0						
	85.80	4	P							
MEDIUM dark gray SILTY LOAM with LIMESTONE fragments		18								
		22								
	83.30	18								
DENSE tan weathered LIMESTONE		18								
		9	1.5	20.0						
	80.80	8	P							

The Unconfined Compressive Strength (UCS) Failure Mode is indicated by (B-Bulge, S-Shear, P-Penetrometer)  
The SPT (N value) is the sum of the last two blow values in each sampling zone (AASHTO T206)

BBS, from 137 (Rev. 8-99)

# BORING LOGS



**Illinois Department of Transportation**  
Division of Highways  
Illinois Department of Transportation/D-2

## SOIL BORING LOG

Page 1 of 1  
Date 4/2/08

ROUTE FA 742 DESCRIPTION P92-064-86 Retaining wall, IL 2 at Mud Creek Road LOGGED BY W. Garza

SECTION 37 RS-3 LOCATION Rockvale Twp. - 28NW, SEC., TWP. 24N, RNG. 10E

COUNTY Ogle DRILLING METHOD Hollow Stem Auger HAMMER TYPE CME-45 Automatic

STRUCT. NO. Station	D E P T H S	B L O W S	U C S Qu	M O I S T ure	Surface Water Elev.	
					ft	
					91.90	ft
						ft
BORING NO. <u>B-2d</u>					Groundwater Elev.:	
Station <u>728+00</u>					92.7	ft ▼
Offset <u>15.00ft Rt CL</u>						ft
Ground Surface Elev. <u>99.70</u>	ft	(ft)	(/6")	(tsf)	(%)	ft

Soil Description	Depth (ft)	Blows (S)	UCS (tsf)	Moisture (%)
Agg Base				
STIFF tan SILTY LOAM	97.70	3		
		4	1.7	21.0
	96.20	5	P	
DENSE white weathered LIMESTONE		20		
		28		
	93.70	9		
MEDIUM brown SILTY CLAY LOAM		3		
		2	0.6	35.0
	91.20	2	P	
SOFT brown SILTY CLAY LOAM		6		
		3	0.5	27.0
	88.70	5	P	
MEDIUM tan weathered LIMESTONE		5		
		8		
	86.20	20		
VERY DENSE tan weathered LIMESTONE		30		
		100/6"		
End of Boring	84.20			

The Unconfined Compressive Strength (UCS) Failure Mode is indicated by (B-Bulge, S-Shear, P-Penetrometer)  
The SPT (N value) is the sum of the last two blow values in each sampling zone (AASHTO T206)

BBS, from 137 (Rev. 8-99)



**Illinois Department of Transportation**  
Division of Highways  
Illinois Department of Transportation/D-2

## SOIL BORING LOG

Page 1 of 1  
Date 4/2/08

ROUTE FA 742 DESCRIPTION P92-064-86 Retaining wall, IL 2 at Mudd Creek LOGGED BY Be. Wetzell

SECTION 37 RS-3 LOCATION Rockvale Twp. - 28NW, SEC., TWP. 24N, RNG. 10E

COUNTY Ogle DRILLING METHOD Hollow Stem Auger HAMMER TYPE CME-45 Automatic

STRUCT. NO. Station	D E P T H S	B L O W S	U C S Qu	M O I S T ure	Surface Water Elev.	
					ft	
					91.90	ft
						ft
BORING NO. <u>B-3d</u>					Groundwater Elev.:	
Station <u>729+00</u>						ft
Offset <u>13.00ft Rt CL</u>						ft
Ground Surface Elev. <u>99.80</u>	ft	(ft)	(/6")	(tsf)	(%)	ft

Soil Description	Depth (ft)	Blows (S)	UCS (tsf)	Moisture (%)
Aggregate Base				
MEDIUM tan SILTY CLAY LOAM	97.80	2		
		2	0.7	26.0
	96.30	4	P	
VERY STIFF gray SILTY CLAY LOAM with LIMESTONE fragments		0		
		8	3.7	21.0
	93.80	12	P	
VERY DENSE tan weathered LIMESTONE		100/1"		
End of Boring	92.30			

The Unconfined Compressive Strength (UCS) Failure Mode is indicated by (B-Bulge, S-Shear, P-Penetrometer)  
The SPT (N value) is the sum of the last two blow values in each sampling zone (AASHTO T206)

BBS, from 137 (Rev. 8-99)

# BORING LOGS



**Illinois Department of Transportation**  
Division of Highways  
Illinois Department of Transportation/D-2

## SOIL BORING LOG

Page 1 of 1

Date 4/2/08

ROUTE FA 742 DESCRIPTION P92-064-86 Retaining wall, IL 2 at Mudd Creek Road LOGGED BY Be. Wetzell

SECTION 37 RS-3 LOCATION Rockvale Twp. - 28 NW, SEC. , TWP. 24N, RNG. 10E

COUNTY Ogle DRILLING METHOD Hollow Stem Auger HAMMER TYPE CME-45 Automatic

STRUCT. NO.	D E P T H	B L O W S	U C S	M O I S T U R E	Groundwater Elev.:			
					Surface Water Elev.	Stream Bed Elev.	First Encounter	Upon Completion
					92.00			
							89.6	ft ▼
							88.6	ft ▼
BORING NO. <u>B-4d</u>								
Station <u>730+00</u>								
Offset <u>16.00ft Rt CL</u>								
Ground Surface Elev. <u>99.60</u> ft	(ft)	(/6")	(tsf)	(%)	(ft)	(/6")	(tsf)	(%)
MEDIUM tan CLAY LOAM			0.8 P	20.0			79.10	
	97.60	2						
SOFT tan SILTY LOAM		3	0.3 P	24.0				
	96.10	2						
VERY STIFF gray SILTY LOAM		4						
		2	4.0 P	21.0				
	93.60	7						
STIFF gray SILTY LOAM with LIMESTONE fragments		2						
		4	1.3 P	23.0				
	91.10	2						
VERY STIFF brown SILTY LOAM with LIMESTONE fragments		3						
		3	2.7 P	24.0				
	88.60	3						
SOFT tan SILTY LOAM		1						
		1	0.5 B	27.0				
	86.10	2						
VERY SOFT tan SANDY LOAM		1						
		0	0.1 P	22.0				
	83.60	3						
DENSE tan weathered LIMESTONE		3						
		14						
	81.10	26						
		100/4"						
	80.10							

The Unconfined Compressive Strength (UCS) Failure Mode is indicated by (B-Bulge, S-Shear, P-Penetrometer)  
The SPT (N value) is the sum of the last two blow values in each sampling zone (AASHTO T206)

BBS, from 137 (Rev. 8-99)



**Illinois Department of Transportation**  
Division of Highways  
Illinois Department of Transportation/D-2

## SOIL BORING LOG

Page 1 of 1

Date 4/2/08

ROUTE FA 742 DESCRIPTION P92-064-6 Retaining wall, IL 2 at Mud Creek Road LOGGED BY W. Garza

SECTION 37 RS-3 LOCATION Rockvale Twp. - 28 NW, SEC. , TWP. 24N, RNG. 10E

COUNTY Ogle DRILLING METHOD Hollow Stem Auger HAMMER TYPE B-53 Diedrich Automatic

STRUCT. NO.	D E P T H	B L O W S	U C S	M O I S T U R E	Groundwater Elev.:			
					Surface Water Elev.	Stream Bed Elev.	First Encounter	Upon Completion
					92.00			
							92.4	ft ▼
BORING NO. <u>B-5d</u>								
Station <u>731+00</u>								
Offset <u>13.00ft Rt CL</u>								
Ground Surface Elev. <u>99.90</u> ft	(ft)	(/6")	(tsf)	(%)	(ft)	(/6")	(tsf)	(%)
SOFT brown SILTY CLAY LOAM			0.4 P	22.0				
	97.40	1						
MEDIUM brown SILTY CLAY LOAM		2	0.8 P	27.0				
	95.90	4						
STIFF dark gray LOAM with LIMESTONE fragments		4						
		8	2.0 P	29.0				
	92.90	11						
No Recovery		4						
		3						
	90.90	3						
LOOSE tan/brown weathered LIMESTONE/LOAM		4						
		3						
	88.40	4						
No Recovery		2						
		1						
	85.40	3						
SOFT gray LOAM with tan weathered LIMESTONE		2						
		2	0.3 P	23.0				
	83.40	3						
VERY DENSE tan weathered LIMESTONE		100/5"						
	81.90							
End of Boring								
	80.10							

The Unconfined Compressive Strength (UCS) Failure Mode is indicated by (B-Bulge, S-Shear, P-Penetrometer)  
The SPT (N value) is the sum of the last two blow values in each sampling zone (AASHTO T206)

BBS, from 137 (Rev. 8-99)

FILE NAME =	USER NAME = grantpm	DESIGNED -	REVISED -	<b>STATE OF ILLINOIS DEPARTMENT OF TRANSPORTATION</b>	<b>BORING LOGS</b>	F.A.P. RTE. 742	SECTION 37R-4	COUNTY OGLE	TOTAL SHEETS 867	SHEET NO. 423	
		DRAWN -	REVISED -			SCALE:	SHEET NO. OF SHEETS	STA.	TO STA.	FED. ROAD DIST. NO.	ILLINOIS FED. AID PROJECT
		CHECKED -	REVISED -								CONTRACT NO. 64E17
		DATE -	REVISED -								





# BORING LOGS



**Illinois Department of Transportation**  
Division of Highways  
Illinois Department of Transportation/D-2

## SOIL BORING LOG

Page 1 of 1  
Date 4/3/08

ROUTE FA 742 DESCRIPTION P92-064-86 Retaining wall, IL 2 at Mud Creek Road LOGGED BY W. Garza

SECTION 37 RS-3 LOCATION Rockvale Twp. - 28NW, SEC. , TWP. 24N, RNG. 10E

COUNTY Ogle DRILLING METHOD Hollow Stem Auger HAMMER TYPE B-53 Diedrich Automatic

STRUCT. NO. Station	D E P T H	B L O W S	U C S Qu	M O I S T	Surface Water Elev.	
					ft	
BORING NO. <u>B-8d</u> Station <u>734+00</u> Offset <u>12.00ft Rt CL</u> Ground Surface Elev. <u>99.90</u> ft	(ft)	(/6")	(tsf)	(%)	First Encounter <u>87.4</u> ft ▼ Upon Completion _____ ft After _____ Hrs. _____ ft	
SOFT brown SILTY CLAY LOAM			0.3 P	24.0		
MEDIUM brown SILTY CLAY LOAM	97.40	1				
	95.90	2 3	0.5 P	27.0		
STIFF gray/brown SILTY CLAY LOAM with LIMESTONE fragments	-5	3				
	93.40	7 10	1.4 B	21.0		
STIFF dark brown SILTY CLAY LOAM with LIMESTONE fragments		3				
	90.90	5 9	1.1 P	22.0		
MEDIUM dark brown SILTY CLAY	-10	3				
	87.90	3 5	0.9 B	32.0		
very little recovery fine SAND and LIMESTONE fragments	▼	3				
	85.90	5 6				
VERY DENSE tan weathered LIMESTONE	-15	1				
	82.90	1 87				
Borehole continued with rock coring.						
	-20					



**Illinois Department of Transportation**  
Division of Highways  
Illinois Department of Transportation/D-2

## SOIL BORING LOG

Page 1 of 1  
Date 4/3/08

ROUTE FA 742 DESCRIPTION P92-064-86 Retaining wall, IL 2 at Mud Creek Road LOGGED BY Be. Wetzell

SECTION 37 RS-3 LOCATION Rockvale Twp. - 28 NW, SEC. , TWP. 24N, RNG. 10E

COUNTY Ogle DRILLING METHOD Hollow Stem Auger HAMMER TYPE CME-45 Automatic

STRUCT. NO. Station	D E P T H	B L O W S	U C S Qu	M O I S T	Surface Water Elev.	
					ft	
BORING NO. <u>B-9d</u> Station <u>735+00</u> Offset <u>13.00ft Rt CL</u> Ground Surface Elev. <u>99.70</u> ft	(ft)	(/6")	(tsf)	(%)	First Encounter _____ ft Upon Completion _____ ft After _____ Hrs. _____ ft	
VERY SOFT gray SILTY LOAM			0.2 P	16.0		
MEDIUM tan SILTY CLAY LOAM	97.70	1				
	96.20	4 5	1.0 B	22.0		
STIFF tan SILTY CLAY LOAM	-5	1				
	93.70	4 7	1.5 B	23.0		
SOFT brown SILTY CLAY LOAM and voids		1				
	90.70	1 2	0.3 P	17.0		
MEDIUM tan weathered LIMESTONE and voids	-10	1				
	88.70	10 5				
MEDIUM tan very weathered LIMESTONE		3				
	86.20	5 7				
VERY DENSE tan weathered LIMESTONE	-15	46				
	83.20	68 32				
End of Boring						
	-20					

The Unconfined Compressive Strength (UCS) Failure Mode is indicated by (B-Bulge, S-Shear, P-Penetrometer)  
The SPT (N value) is the sum of the last two blow values in each sampling zone (AASHTO T206)

BBS, from 137 (Rev. 8-99)

The Unconfined Compressive Strength (UCS) Failure Mode is indicated by (B-Bulge, S-Shear, P-Penetrometer)  
The SPT (N value) is the sum of the last two blow values in each sampling zone (AASHTO T206)

BBS, from 137 (Rev. 8-99)

FILE NAME =	USER NAME = grantpm	DESIGNED -	REVISED -	<b>STATE OF ILLINOIS DEPARTMENT OF TRANSPORTATION</b>	<b>BORING LOGS</b>	F.A.P RTE. 742	SECTION 37R-4	COUNTY OGLE	TOTAL SHEETS 867	SHEET NO. 425	
ct:\pw_work\PW\DOT\GRANTPM\dms31213\080608logs.dgn		DRAWN -	REVISED -			SCALE:	SHEET NO. OF SHEETS	STA.	TO STA.	FED. ROAD DIST. NO.	ILLINOIS FED. AID PROJECT
PLOT SCALE = 1/8"=1'-0" 1/4" = 1'-0"		CHECKED -	REVISED -								
PLOT DATE = Tue Mar 30 09:31:28 2010		DATE -	REVISED -								

# BORING LOGS

Page 1 of 1

**SOIL BORING LOG**

Date 4/3/08

ROUTE FA 742 DESCRIPTION P92-064-86 Retaining wall, IL 2 at Mud Creek Road LOGGED BY Be. Wetzell

SECTION 37 RS-3 LOCATION Rockvale Twp. - 28 NW, SEC., TWP. 24N, RNG. 10E

COUNTY Ogle DRILLING METHOD Hollow Stem Auger HAMMER TYPE CME-45 Automatic

STRUCT. NO. \_\_\_\_\_  
 Station \_\_\_\_\_

BORING NO. B-10d  
 Station 736+00  
 Offset 13.00ft Rt CL  
 Ground Surface Elev. 99.80 ft

DEPTH (ft)	SOIL DESCRIPTION	U (Bulge)	M (SPT)	Surface Water Elev. (ft)	Stream Bed Elev. (ft)	Groundwater Elev. (ft)
97.80	STIFF gray SILTY LOAM	1.3 P	19.0	91.50		
96.30	STIFF tan SILTY CLAY LOAM	1.6 P	24.0			
93.80	VERY STIFF tan SILTY CLAY LOAM	2.4 P	24.0			
91.30	MEDIUM gray SILTY CLAY LOAM	0.9 P	25.0			
88.30	SOFT brown SILTY CLAY LOAM with LIMESTONE fragments	0.4 P	27.0			
86.30	SOFT tan very weathered LIMESTONE					
83.80	VERY DENSE tan weathered LIMESTONE					
83.80	Auger Refusal					
83.80	End of Boring					

The Unconfined Compressive Strength (UCS) Failure Mode is indicated by (B-Bulge, S-Shear, P-Penetrometer)  
 The SPT (N value) is the sum of the last two blow values in each sampling zone (AASHTO T206)

BBS, from 137 (Rev. 8-99)

Page 1 of 1

**SOIL BORING LOG**

Date 4/3/08

ROUTE FA 742 DESCRIPTION P92-064-86 Retaining wall, IL 2 at Mud Creek Road LOGGED BY Be. Wetzell

SECTION 37 RS-3 LOCATION Rockvale Twp. - 28 NW, SEC., TWP. 24N, RNG. 10E

COUNTY Ogle DRILLING METHOD Hollow Stem Auger HAMMER TYPE CME-45 Automatic

STRUCT. NO. \_\_\_\_\_  
 Station \_\_\_\_\_

BORING NO. B-11d  
 Station 737+00  
 Offset 13.00ft Rt CL  
 Ground Surface Elev. 99.70 ft

DEPTH (ft)	SOIL DESCRIPTION	U (Bulge)	M (SPT)	Surface Water Elev. (ft)	Stream Bed Elev. (ft)	Groundwater Elev. (ft)
97.70	SOFT tan SILTY LOAM	0.4 P	16.0	91.10		
96.20	VERY STIFF tan SILTY LOAM	2.1 P	23.0			
93.20	VERY STIFF gray SILTY LOAM	2.7 P	24.0			
91.20	SOFT tan weathered LIMESTONE and voids					
88.70	MEDIUM tan weathered LIMESTONE					
86.20	No Recovery					
83.70	VERY DENSE white weathered LIMESTONE					
83.70	Auger Refusal					
83.70	End of Boring					

The Unconfined Compressive Strength (UCS) Failure Mode is indicated by (B-Bulge, S-Shear, P-Penetrometer)  
 The SPT (N value) is the sum of the last two blow values in each sampling zone (AASHTO T206)

BBS, from 137 (Rev. 8-99)

# BORING LOGS



**Illinois Department of Transportation**  
Division of Highways  
Illinois Department of Transportation/D-2

## SOIL BORING LOG

Page 1 of 1  
Date 4/3/08

ROUTE FA 742 DESCRIPTION P92-064-86 Retaining wall, IL 2 at Mud Creek Road LOGGED BY Be. Wetzell

SECTION 37 RS-3 LOCATION Rockvale Twp. - 28 NW, SEC., TWP. 24N, RNG. 10E

COUNTY Ogle DRILLING METHOD Hollow Stem Auger HAMMER TYPE CME-45 Automatic

STRUCT. NO. Station	D E P T H H	B L O W S	U C S Qu	M O I S T ure	Surface Water Elev. Stream Bed Elev.	D E P T H H	B L O W S	U C S Qu	M O I S T ure
BORING NO. <u>B-12d</u> Station <u>738+00</u> Offset <u>13.00ft Rt CL</u> Ground Surface Elev. <u>99.70</u> ft					91.00 ft Stream Bed Elev. _____ ft				
					Groundwater Elev.: First Encounter <u>90.2</u> ft Upon Completion <u>89.7</u> ft After _____ Hrs.				
MEDIUM tan SILTY CLAY LOAM			0.7 P	19.0	DENSE tan weathered LIMESTONE (continued)	13 20			
STIFF tan SILTY LOAM	97.70	3			DENSE tan weathered LIMESTONE	15 16 29			
MEDIUM gray SILTY LOAM	96.20	4	2.0 B	23.0	DENSE tan weathered LIMESTONE	17 21 17			
LOOSE tan weathered LIMESTONE with SILT lenses	93.20	5 6	1.2 B	24.0	DENSE tan weathered LIMESTONE	11 17 11			
VERY LOOSE tan weathered LIMESTONE with SILT lenses	91.20	2 3			MEDIUM brown weathered LIMESTONE	9 7 6			
No Recovery	88.70	1			End of Boring				
VERY LOOSE tan very weathered LIMESTONE	86.20	2							
DENSE tan weathered LIMESTONE	83.70	1							
	81.20	17 20 23							
		16							

The Unconfined Compressive Strength (UCS) Failure Mode is indicated by (B-Bulge, S-Shear, P-Penetrometer)  
The SPT (N value) is the sum of the last two blow values in each sampling zone (AASHTO T206)

BBS, from 137 (Rev. 8-99)



**Illinois Department of Transportation**  
Division of Highways  
Illinois Department of Transportation/D-2

## SOIL BORING LOG

Page 1 of 1  
Date 4/4/08

ROUTE FA 742 DESCRIPTION P92-064-86 Retaining wall, IL 2 at Mud Creek Road LOGGED BY Be. Wetzell

SECTION 37 RS-3 LOCATION Rockvale Twp. - 28 NW, SEC., TWP. 24N, RNG. 10E

COUNTY Ogle DRILLING METHOD Hollow Stem Auger HAMMER TYPE CME-45 Automatic

STRUCT. NO. Station	D E P T H H	B L O W S	U C S Qu	M O I S T ure	Surface Water Elev. Stream Bed Elev.	D E P T H H	B L O W S	U C S Qu	M O I S T ure
BORING NO. <u>B-13d</u> Station <u>739+00</u> Offset <u>12.00ft Rt CL</u> Ground Surface Elev. <u>99.90</u> ft					90.00 ft Stream Bed Elev. _____ ft				
					Groundwater Elev.: First Encounter <u>87.9</u> ft Upon Completion <u>89.9</u> ft After _____ Hrs.				
MEDIUM brown SILTY CLAY LOAM			0.8 P	24.0	DENSE tan weathered LIMESTONE (continued)	18 26			
STIFF brown SILTY CLAY LOAM with SAND lens	97.90	3			MEDIUM tan weathered LIMESTONE	18 13 11			
STIFF gray SILTY LOAM	96.40	5 6	1.4 P	24.0	DENSE tan weathered LIMESTONE	17 14 18			
LOOSE gray dirty SAND	93.40	2 2 3			VERY DENSE tan weathered LIMESTONE	59 100/7'			
VERY LOOSE gray dirty SAND with LIMESTONE fragments	91.40	2 1 3			Auger Refusal at 29'	70.90			
LOOSE gray dirty weathered LIMESTONE	88.90	2 6 3			End of Boring				
LOOSE tan weathered LIMESTONE	86.40	2 3 3							
DENSE tan weathered LIMESTONE	83.90	25 19 18							
	81.40	19							

The Unconfined Compressive Strength (UCS) Failure Mode is indicated by (B-Bulge, S-Shear, P-Penetrometer)  
The SPT (N value) is the sum of the last two blow values in each sampling zone (AASHTO T206)

BBS, from 137 (Rev. 8-99)

# BORING LOGS



**Illinois Department of Transportation**  
Division of Highways  
Illinois Department of Transportation/D-2

## SOIL BORING LOG

Page 1 of 1

Date 4/4/08

ROUTE FA 742 DESCRIPTION P92-064-86 Retaining wall, IL 2 at Mud Creek Road LOGGED BY Be. Wetzell

SECTION 37 RS-3 LOCATION Rockvale Twp. - 28 NW, SEC. , TWP. 24N, RNG. 10E

COUNTY Ogle DRILLING METHOD Hollow Stem Auger HAMMER TYPE CME-45 Automatic

STRUCT. NO. Station	D E P T H  ft	B L O W S  (ft)	U C S  (tsf)	M O I S T  (%)	Surface Water Elev. _____ ft	Stream Bed Elev. _____ ft	Groundwater Elev.: First Encounter _____ ft	Upon Completion _____ ft	After _____ Hrs. _____ ft	D E P T H  ft	B L O W S  (ft)	U C S  (tsf)	M O I S T  (%)
8" Asphalt					90.00		92.4	95.9					
STIFF brown SILTY CLAY LOAM			1.8	18.0		78.90							
	97.90	3											
STIFF brown SILTY CLAY LOAM			5	1.4	24.0								
	96.40	7	P			77.40							
STIFF gray SILTY CLAY LOAM with SAND lens			3										
	93.40	4	1.7	21.0									
		5	B										
LOOSE tan weathered LIMESTONE			4										
	90.90	4											
VERY SOFT dark gray SILTY LOAM with ORGANICS			1										
	88.40	2	0.2	36.0									
		2	P										
VERY LOOSE tan weathered LIMESTONE			1										
	86.40	1											
		2											
MEDIUM tan weathered LIMESTONE			1										
	83.90	4											
		15											
MEDIUM tan weathered LIMESTONE			17										
	81.40	17											
		12											
		23											

The Unconfined Compressive Strength (UCS) Failure Mode is indicated by (B-Bulge, S-Shear, P-Penetrometer)  
The SPT (N value) is the sum of the last two blow values in each sampling zone (AASHTO T206)

BBS, from 137 (Rev. 8-99)



**Illinois Department of Transportation**  
Division of Highways  
Illinois Department of Transportation/D-2

## SOIL BORING LOG

Page 1 of 1

Date 4/3/08

ROUTE FA 742 DESCRIPTION P92-064-86 Retaining wall, IL 2 at Mud Creek Road LOGGED BY Be. Wetzell

SECTION 37 RS-3 LOCATION Rockvale Twp. - 28 NW, SEC. , TWP. 24N, RNG. 10E

COUNTY Ogle DRILLING METHOD Hollow Stem Auger HAMMER TYPE CME-45 Automatic

STRUCT. NO. Station	D E P T H  ft	B L O W S  (ft)	U C S  (tsf)	M O I S T  (%)	Surface Water Elev. _____ ft	Stream Bed Elev. _____ ft	Groundwater Elev.: First Encounter _____ ft	Upon Completion _____ ft	After _____ Hrs. _____ ft	D E P T H  ft	B L O W S  (ft)	U C S  (tsf)	M O I S T  (%)
MEDIUM brown SILTY CLAY LOAM			0.5	25.0		90.40							
						78.40							
LOOSE/MEDIUM brown SAND			5										
	97.40	5											
		5											
STIFF gray SILTY CLAY LOAM			3										
	95.90	5				75.90							
VERY SOFT dark brown LOAM with LIMESTONE fragments			2	0.2	29.0								
	93.40	4	1.9	23.0									
		5	B										
VERY SOFT gray LOAM with LIMESTONE fragments			2										
	90.90	2											
		3	P										
VERY SOFT gray LOAM with LIMESTONE fragments			4										
	87.90	1	0.0	23.0									
		5	P										
MEDIUM tan weathered LIMESTONE			9										
	85.90	5											
		8											
VERY LOOSE tan fine SAND with SILT lens			1										
	82.90	0											
		4											
DENSE tan weathered LIMESTONE			15										
	80.90	14											
		18											

The Unconfined Compressive Strength (UCS) Failure Mode is indicated by (B-Bulge, S-Shear, P-Penetrometer)  
The SPT (N value) is the sum of the last two blow values in each sampling zone (AASHTO T206)

BBS, from 137 (Rev. 8-99)

# BORING LOGS



**Illinois Department of Transportation**  
Division of Highways  
Illinois Department of Transportation/D-2

## SOIL BORING LOG

Page 1 of 1  
Date 6/15/09

ROUTE FA 742 DESCRIPTION P92-064-86 IL 2 Retaining Wall, .3 m. N. of Mud Creek Road LOGGED BY W. Garza

SECTION 37 RS-3 LOCATION Rockvale Twp. - 21SW, SEC. , TWP. 24N, RNG. 10E

COUNTY Ogle DRILLING METHOD Hollow Stem Auger HAMMER TYPE CME-45 Automatic

STRUCT. NO. Station	D E P T H	B L O W S	U C S Qu	M O I S T U R E	Surface Water Elev. _____ ft	Stream Bed Elev. _____ ft	Groundwater Elev.: First Encounter _____ ft	Upon Completion _____ ft	After _____ Hrs. _____ ft	D E P T H	B L O W S	U C S Qu	M O I S T U R E
MEDIUM brown LOAM			0.6 P	15.0			DENSE tan weathered LIMESTONE (continued)	662.70		14			
										30			
VERY STIFF brown SILTY CLAY LOAM	681.70	3					DENSE tan weathered LIMESTONE			3			
		4	2.7	23.0						16			
	680.20	6	B					660.20		16			
STIFF brown SILTY CLAY LOAM with SAND lens		2					DENSE tan weathered LIMESTONE			20			
		3	1.5	24.0						19			
	677.70	6	B					657.70		22			
SOFT gray LOAM		0					DENSE tan weathered LIMESTONE			20			
		2	0.3	25.0						20			
	674.70	2	B					655.20		22			
DENSE tan weathered LIMESTONE		2					MEDIUM tan weathered LIMESTONE			8			
		5								12			
		33								16			
	672.20						End of Boring						
MEDIUM dark gray SILTY CLAY LOAM with ORGANICS		0											
		1	0.9	32.0									
	670.20	3	B										
No Recovery		0											
		2											
	667.70	3											
SOFT brown SILTY CLAY LOAM with LIMESTONE fragments		0											
		1	0.4	29.0									
	664.70	3	B										
		2											

The Unconfined Compressive Strength (UCS) Failure Mode is indicated by (B-Bulge, S-Shear, P-Penetrometer)  
The SPT (N value) is the sum of the last two blow values in each sampling zone (AASHTO T206)

BBS, from 137 (Rev. 8-99)



**Illinois Department of Transportation**  
Division of Highways  
Illinois Department of Transportation/D-2

## SOIL BORING LOG

Page 1 of 1  
Date 6/15/09

ROUTE FA 742 DESCRIPTION P92-064-86 IL 2 Retaining Wall, .3 m. N. of Mud Creek Road LOGGED BY W. Garza

SECTION 37 RS-3 LOCATION Rockvale Twp. - 21SW, SEC. , TWP. 24N, RNG. 10E

COUNTY Ogle DRILLING METHOD Hollow Stem Auger HAMMER TYPE CME-45 Automatic

STRUCT. NO. Station	D E P T H	B L O W S	U C S Qu	M O I S T U R E	Surface Water Elev. _____ ft	Stream Bed Elev. _____ ft	Groundwater Elev.: First Encounter _____ ft	Upon Completion _____ ft	After _____ Hrs. _____ ft	D E P T H	B L O W S	U C S Qu	M O I S T U R E
STIFF brown SILTY CLAY LOAM			1.0 P	23.0			MEDIUM tan weathered LIMESTONE (continued)	662.70		9			
										10			
LOOSE brown dry medium SAND		5					MEDIUM tan weathered LIMESTONE			17			
		5								21			
	680.20	4						660.20		13			
MEDIUM brown medium SAND with SILTY CLAY LOAM		6					VERY LOOSE tan weathered LIMESTONE			2			
		6	0.8	24.0						1			
	677.70	5	P					657.70		2			
MEDIUM tan weathered LIMESTONE		13					VERY LOOSE tan weathered LIMESTONE			1			
		12								0			
	674.70	10						655.20		1			
MEDIUM tan SILT with LIMESTONE fragments		11					MEDIUM tan weathered LIMESTONE			6			
		6	0.5	19.0						7			
		7	P							8			
	672.20						End of Boring						
MEDIUM tan weathered LIMESTONE		8											
		8											
	670.20	12											
DENSE tan weathered LIMESTONE		6											
		20											
	667.70	26											
MEDIUM tan weathered LIMESTONE		16											
		16											
	665.20	11											
		9											

The Unconfined Compressive Strength (UCS) Failure Mode is indicated by (B-Bulge, S-Shear, P-Penetrometer)  
The SPT (N value) is the sum of the last two blow values in each sampling zone (AASHTO T206)

BBS, from 137 (Rev. 8-99)

# BORING LOGS



**Illinois Department of Transportation**  
Division of Highways  
Illinois Department of Transportation/D-2

## SOIL BORING LOG

Page 1 of 1

Date 6/15/09

ROUTE FA 742 DESCRIPTION P92-064-86 IL 2 Retaining Wall, .3 m. N. of Mud Creek Road LOGGED BY W. Garza

SECTION 37 RS-3 LOCATION Rockvale Twp. - 21SW, SEC., TWP. 24N, RNG. 10E

COUNTY Ogle DRILLING METHOD Hollow Stem Auger HAMMER TYPE CME-45 Automatic

STRUCT. NO.	D E P T H (ft)	B L O W S (/6")	U N C O M P R E S S I O N (tsf)	M O I S T U R E (%)	Surface Water Elev. _____ ft Stream Bed Elev. _____ ft	Groundwater Elev.: First Encounter _____ ft ▽ Upon Completion _____ ft ▽ After _____ Hrs. _____ ft
MEDIUM brown SILTY CLAY LOAM			0.6 P	22.0		
STIFF brown SILTY CLAY LOAM with SAND lens	681.40	3	1.1 P	22.0		
STIFF brown SILTY CLAY LOAM	676.90	2	1.1 B	23.0		
DENSE tan weathered LIMESTONE	674.90	4 16 24				
MEDIUM tan weathered LIMESTONE	672.40	18 12 14				
DENSE tan weathered LIMESTONE	669.90	13 22 25				
DENSE tan weathered LIMESTONE	667.40	48 25 14				
VERY DENSE tan weathered LIMESTONE	665.40	100/2"				
Auger Refusal at 18' Borehole continued with rock coring.						

The Unconfined Compressive Strength (UCS) Failure Mode is indicated by (B-Bulge, S-Shear, P-Penetrometer)  
The SPT (N value) is the sum of the last two blow values in each sampling zone (AASHTO T206)

BBS, from 137 (Rev. 8-99)



**Illinois Department of Transportation**  
Division of Highways  
Illinois Department of Transportation/D-2

## SOIL BORING LOG

Page 1 of 1

Date 6/15/09

ROUTE FA 742 DESCRIPTION P92-064-86 IL 2 Retaining Wall, .3 m. N. of Mud Creek Road LOGGED BY W. Garza

SECTION 37 RS-3 LOCATION Rockvale Twp. - 21SW, SEC., TWP. 24N, RNG. 10E

COUNTY Ogle DRILLING METHOD Hollow Stem Auger HAMMER TYPE CME-45 Automatic

STRUCT. NO.	D E P T H (ft)	B L O W S (/6")	U N C O M P R E S S I O N (tsf)	M O I S T U R E (%)	Surface Water Elev. _____ ft Stream Bed Elev. _____ ft	Groundwater Elev.: First Encounter _____ ft ▽ Upon Completion _____ ft ▽ After _____ Hrs. _____ ft
DENSE tan weathered LIMESTONE (continued)	662.80				18 19	
MEDIUM brown dry medium SAND	681.80	8 11 12			7 6 13	
MEDIUM brown/tan medium SAND	677.30	8 11 7			31 35 13	
MEDIUM dark gray SILTY CLAY LOAM with SAND lens	675.30	4 4 4	0.6 P	29.0	19 17 17	
STIFF dark gray SILTY LOAM	672.80	4 5 6	1.8 S	21.0	12 35 21	
MEDIUM brown SILTY CLAY LOAM	670.30	0 3 4	0.6 B	30.0		
MEDIUM brown SILTY CLAY LOAM	667.80	1 2 2	0.7 B	28.0		
SOFT brown SILT LOAM	664.80	0 0 3	0.4 B	32.0		
End of Boring						

The Unconfined Compressive Strength (UCS) Failure Mode is indicated by (B-Bulge, S-Shear, P-Penetrometer)  
The SPT (N value) is the sum of the last two blow values in each sampling zone (AASHTO T206)

BBS, from 137 (Rev. 8-99)

# BORING LOGS

	<b>Illinois Department of Transportation</b> <small>Division of Highways          Illinois Department of Transportation/D-2</small>	<b>SOIL BORING LOG</b>	Page <u>1</u> of <u>1</u> Date <u>6/16/09</u>
	ROUTE <u>FA 742</u> DESCRIPTION <u>P92-064-86 IL 2 Retaining Wall, .3 m. N. of Mud Creek Road</u> LOGGED BY <u>W. Garza</u>		
SECTION <u>37 RS-3</u> LOCATION <u>Rockvale Twp. - 21SW, SEC. , TWP. 24N, RNG. 10E</u>			
COUNTY <u>Ogle</u> DRILLING METHOD <u>Hollow Stem Auger</u> HAMMER TYPE <u>CME-45 Automatic</u>			
STRUCT. NO. _____ Station _____	D E P T H  B L O W S  U S Q u  M O I S T S S 	Surface Water Elev. _____ ft Stream Bed Elev. _____ ft  Groundwater Elev.: First Encounter <u>669.0</u> ft ▽ Upon Completion <u>673.5</u> ft ▽ After _____ Hrs. _____ ft	D E P T H  B L O W S  U S Q u  M O I S T S S
BORING NO. <u>B-5k</u> Station <u>743+91</u> Offset <u>15.00ft Lt CL</u> Ground Surface Elev. <u>683.50</u> ft	(ft) (/6") (tsf) (%)	DENSE tan weathered LIMESTONE (continued) _____ 20 _____ 14  MEDIUM tan weathered LIMESTONE _____ 23 _____ 14 _____ 15  MEDIUM tan weathered LIMESTONE _____ 7 _____ 4 _____ 11  VERY DENSE tan weathered LIMESTONE _____ 45 _____ 100/6" _____ 17 _____ 17  VERY DENSE tan weathered LIMESTONE _____ 100/3" _____ 11 _____ 12  End of Boring _____ 652.50   MEDIUM tan weathered LIMESTONE _____ 12 _____ 13 _____ 13  DENSE tan weathered LIMESTONE _____ 18 _____ 12 _____ 26  DENSE tan weathered LIMESTONE _____ 20 _____ 15 _____ 18  _____ 16 _____ 20	(ft) (/6") (tsf) (%)
<p>The Unconfined Compressive Strength (UCS) Failure Mode is indicated by (B-Bulge, S-Shear, P-Penetrometer)          The SPT (N value) is the sum of the last two blow values in each sampling zone (AASHTO T206)</p> <p style="text-align:right;">BBS, from 137 (Rev. 8-99)</p>			

	<b>Illinois Department of Transportation</b> <small>Division of Highways          Illinois Department of Transportation/D-2</small>	<b>SOIL BORING LOG</b>	Page <u>1</u> of <u>1</u> Date <u>6/16/09</u>
	ROUTE <u>FA 742</u> DESCRIPTION <u>P92-064-86 IL 2 Retaining Wall, .3 m. N. of Mud Creek Road</u> LOGGED BY <u>W. Garza</u>		
SECTION <u>37 RS-3</u> LOCATION <u>Rockvale Twp. - 21SW, SEC. , TWP. 24N, RNG. 10E</u>			
COUNTY <u>Ogle</u> DRILLING METHOD <u>Hollow Stem Auger</u> HAMMER TYPE <u>CME-45 Automatic</u>			
STRUCT. NO. _____ Station _____	D E P T H  B L O W S  U S Q u  M O I S T S S	Surface Water Elev. _____ ft Stream Bed Elev. _____ ft  Groundwater Elev.: First Encounter _____ ft Upon Completion _____ ft After _____ Hrs. _____ ft	D E P T H  B L O W S  U S Q u  M O I S T S S
BORING NO. <u>B-5k</u> Station <u>744+00</u> Offset <u>15.00ft Rt CL</u> Ground Surface Elev. <u>683.70</u> ft	(ft) (/6") (tsf) (%)	STIFF brown SILTY CLAY LOAM _____ _____ 1.8 _____ P 17.0  VERY STIFF brown SILTY CLAY LOAM _____ 3 _____ 5 2.5 22.0 _____ 7 B  STIFF gray SILTY CLAY LOAM with SAND lens _____ 1 _____ 2 1.1 22.0 _____ 3 B  _____ 676.70  Concrete top 6" VERY DENSE tan weathered LIMESTONE or FILL Auger Refusal at 7.0' Moved to 744+10, 15' Rt. Hit Concrete at 6.5' End of Boring _____ -10  _____ 5 _____ 9 _____ 100  _____ -15 _____ -20	(ft) (/6") (tsf) (%)
<p>The Unconfined Compressive Strength (UCS) Failure Mode is indicated by (B-Bulge, S-Shear, P-Penetrometer)          The SPT (N value) is the sum of the last two blow values in each sampling zone (AASHTO T206)</p> <p style="text-align:right;">BBS, from 137 (Rev. 8-99)</p>			

FILE NAME =	USER NAME = grantpm	DESIGNED -	REVISED -	<b>STATE OF ILLINOIS DEPARTMENT OF TRANSPORTATION</b>	<b>BORING LOGS</b>	F.A.P. RTE.	SECTION	COUNTY	TOTAL SHEETS	SHEET NO.
cr\pw_work\PWIDOT\GRANTPM\dms31213\dl0866291logs.dgn		DRAWN -	REVISED -			742	37R-4	OGLE	867	431
PLOT SCALE = 1/8" = 1' IN.		CHECKED -	REVISED -			CONTRACT NO. 64E17				
PLOT DATE = Tue Mar 30 09:31:33 2010		DATE -	REVISED -			SCALE: SHEET NO. OF SHEETS STA. TO STA.		FED. ROAD DIST. NO. ILLINOIS FED. AID PROJECT		

# BORING LOGS



**Illinois Department of Transportation**  
Division of Highways  
Illinois Department of Transportation/D-2

## SOIL BORING LOG

Page 1 of 2  
Date 9/25/08

ROUTE FA 742 DESCRIPTION P92-064-86 Box culvert relocate, N. of Town Hall Road LOGGED BY W. Garza

SECTION 37 RS-3 LOCATION Rockvale Twp. - 14SW, SEC. , TWP. 24N, RNG. 10E

COUNTY Ogle DRILLING METHOD Hollow Stem Auger HAMMER TYPE CME-45 Automatic

STRUCT. NO. \_\_\_\_\_  
Station 834+27

BORING NO. B-1h  
Station 834+20  
Offset 14.00ft Rt CL  
Ground Surface Elev. 99.60 ft

SOIL DESCRIPTION	DEPTH (ft)	BLOW COUNT	UNIFIED SOIL CLASSIFICATION	ELEVATION (ft)	TEST TYPE	RESULTS	DELTAS						
							(ft)	(/6")	(tsf)	(%)			
Shoulder Rock													
LOOSE light gray clean medium coarse SAND (continued)				78.60			3						
							5						
STIFF brown SILTY CLAY LOAM	97.60	2											
		2	1.1	22.0									
	96.10	3	P										
MEDIUM black SILTY LOAM		2											
		2	0.5	35.0									
	93.60	4	P										
MEDIUM black SILTY LOAM		1											
		2	0.8	37.0									
	91.10	5	P										
MEDIUM brown SILTY CLAY LOAM		2											
		3	0.9	32.0									
	88.60	5	B										
VERY SOFT tan SILTY LOAM		2											
		1	0.2	36.0									
	85.60	2	B										
VERY LOOSE tan dirty SAND		0											
		1											
	83.60	1											
LOOSE tan clean medium coarse SAND		2											
		4											
	81.10	5											
		2											
	-20												

Surface Water Elev. \_\_\_\_\_ ft  
Stream Bed Elev. 95.00 ft

Groundwater Elev.:  
First Encounter \_\_\_\_\_ ft  
Upon Completion 84.6 ft  
After \_\_\_\_\_ Hrs. \_\_\_\_\_ ft

The Unconfined Compressive Strength (UCS) Failure Mode is indicated by (B-Bulge, S-Shear, P-Penetrometer)  
The SPT (N value) is the sum of the last two blow values in each sampling zone (AASHTO T206)

BBS, from 137 (Rev. 8-99)



**Illinois Department of Transportation**  
Division of Highways  
Illinois Department of Transportation/D-2

## SOIL BORING LOG

Page 2 of 2  
Date 9/25/08

ROUTE FA 742 DESCRIPTION P92-064-86 Box culvert relocate, N. of Town Hall Road LOGGED BY W. Garza

SECTION 37 RS-3 LOCATION Rockvale Twp. - 14SW, SEC. , TWP. 24N, RNG. 10E

COUNTY Ogle DRILLING METHOD Hollow Stem Auger HAMMER TYPE CME-45 Automatic

STRUCT. NO. \_\_\_\_\_  
Station 834+27

BORING NO. B-1h  
Station 834+20  
Offset 14.00ft Rt CL  
Ground Surface Elev. 99.60 ft

SOIL DESCRIPTION	DEPTH (ft)	BLOW COUNT	UNIFIED SOIL CLASSIFICATION	ELEVATION (ft)	TEST TYPE	RESULTS	DELTAS						
							(ft)	(/6")	(tsf)	(%)			
MEDIUM tan clean medium coarse SAND (continued)				58.60			5						
							10						
End of Boring													

Surface Water Elev. \_\_\_\_\_ ft  
Stream Bed Elev. 95.00 ft

Groundwater Elev.:  
First Encounter \_\_\_\_\_ ft  
Upon Completion 84.6 ft  
After \_\_\_\_\_ Hrs. \_\_\_\_\_ ft

The Unconfined Compressive Strength (UCS) Failure Mode is indicated by (B-Bulge, S-Shear, P-Penetrometer)  
The SPT (N value) is the sum of the last two blow values in each sampling zone (AASHTO T206)

BBS, from 137 (Rev. 8-99)



# BORING LOGS



**Illinois Department of Transportation**  
Division of Highways  
Illinois Department of Transportation/D-2

## SOIL BORING LOG

Page 1 of 2

Date 9/25/08

ROUTE FA 742 DESCRIPTION P92-064-86 Box culvert relocate, N. of Town Hall Road LOGGED BY W. Garza

SECTION 37 RS-3 LOCATION Rockvale Twp. - 15SW, SEC., TWP. 24N, RNG. 10E

COUNTY Ogle DRILLING METHOD Hollow Stem Auger HAMMER TYPE CME-45 Automatic

STRUCT. NO. \_\_\_\_\_  
Station 834+27

BORING NO. B-2h  
Station 834+28  
Offset 14.00ft Lt CL  
Ground Surface Elev. 100.00 ft

Description	D E P T H H S	B L O W S Qu	U C S T	M O I S T %	Surface Water Elev. _____ ft	Stream Bed Elev. _____ ft	Groundwater Elev.: First Encounter _____ ft	Upon Completion _____ ft	After _____ Hrs. _____ ft	D E P T H H S	B L O W S Qu	U C S T	M O I S T %
STIFF brown SILTY LOAM	3				98.00								
	4	1.3		20.0									
	6				96.50								
STIFF brown SILTY LOAM	3												
	4	1.8		16.0									
	6	P			94.00								
MEDIUM brown SILTY LOAM	1												
	3	0.8		39.0									
	5	P			91.50								
MEDIUM brown SILTY CLAY LOAM	1												
	4	0.8		33.0									
	5	B			89.00								
SOFT tan SILTY LOAM	0												
	0	0.3		35.0									
	2	B			86.50								
VERY SOFT tan SILTY LOAM with SAND lens	0												
	0	0.2		35.0									
	1	B			83.50								
VERY LOOSE tan fine SAND	1												
	1												
	3				81.50								
	2												

The Unconfined Compressive Strength (UCS) Failure Mode is indicated by (B-Bulge, S-Shear, P-Penetrometer)  
The SPT (N value) is the sum of the last two blow values in each sampling zone (AASHTO T206)

BBS, from 137 (Rev. 8-99)



**Illinois Department of Transportation**  
Division of Highways  
Illinois Department of Transportation/D-2

## SOIL BORING LOG

Page 2 of 2

Date 9/25/08

ROUTE FA 742 DESCRIPTION P92-064-86 Box culvert relocate, N. of Town Hall Road LOGGED BY W. Garza

SECTION 37 RS-3 LOCATION Rockvale Twp. - 15SW, SEC., TWP. 24N, RNG. 10E

COUNTY Ogle DRILLING METHOD Hollow Stem Auger HAMMER TYPE CME-45 Automatic

STRUCT. NO. \_\_\_\_\_  
Station 834+27

BORING NO. B-2h  
Station 834+28  
Offset 14.00ft Lt CL  
Ground Surface Elev. 100.00 ft

Description	D E P T H H S	B L O W S Qu	U C S T	M O I S T %	Surface Water Elev. _____ ft	Stream Bed Elev. _____ ft	Groundwater Elev.: First Encounter _____ ft	Upon Completion _____ ft	After _____ Hrs. _____ ft	D E P T H H S	B L O W S Qu	U C S T	M O I S T %
MEDIUM tan clean medium coarse SAND (continued)	5				59.00								
	9												
					56.50								
MEDIUM tan clean medium coarse SAND	3												
	6												
	8				54.00								
End of Boring													

The Unconfined Compressive Strength (UCS) Failure Mode is indicated by (B-Bulge, S-Shear, P-Penetrometer)  
The SPT (N value) is the sum of the last two blow values in each sampling zone (AASHTO T206)

BBS, from 137 (Rev. 8-99)

# BORING LOGS

**Illinois Department of Transportation**  
Division of Highways  
Illinois Department of Transportation/D-2

**SOIL BORING LOG**

Page 1 of 1  
Date 5/6/08

ROUTE FA 742 DESCRIPTION P92-064-86 Retaining wall, IL 2, 2.8 m. N. of Mud Creek Road LOGGED BY W. Garza

SECTION 37 RS-3 LOCATION Rockvale Twp. - 10SW, SEC. , TWP. 24N, RNG. 10E

COUNTY Ogle DRILLING METHOD Hollow Stem Auger HAMMER TYPE CME-45 Automatic

STRUCT. NO. \_\_\_\_\_  
Station \_\_\_\_\_

BORING NO. B-15e  
Station 863+00  
Offset 15.00ft Rt CL  
Ground Surface Elev. 682.20 ft

SOIL DESCRIPTION	DEPTH (ft)	BULGE (1/6")	SHEAR (tsf)	PENETRATION (%)	ELEVATION (ft)	TEST TYPE	TEST RESULTS			
							DEPTH (ft)	BULGE (1/6")	SHEAR (tsf)	PENETRATION (%)
LOOSE dark brown dirty SAND				13.0	661.20	DLCS	6	8		
STIFF dark brown SANDY LOAM	680.20	3								
	678.70	4	1.5	17.0						
		5	P		658.70					
MEDIUM brown LOAM		1								
	676.20	3	0.7	16.0						
		4	B		656.20					
MEDIUM brown SILTY CLAY LOAM		1								
	673.70	2	0.7	29.0						
		3	B		653.70					
VERY SOFT tan LOAM		0								
	670.70	1	0.2	26.0						
		1	P		651.20					
LOOSE tan clean medium coarse SAND		1								
	668.70	2								
		5								
Wash		1								
LOOSE tan fine SAND		3								
	666.20	2								
	663.70									
MEDIUM tan SANDY GRAVEL		5								

Surface Water Elev. \_\_\_\_\_ ft  
Stream Bed Elev. \_\_\_\_\_ ft  
Groundwater Elev.:  
First Encounter 670.2 ft ▼  
Upon Completion Wash ft  
After \_\_\_\_\_ Hrs. \_\_\_\_\_ ft

The Unconfined Compressive Strength (UCS) Failure Mode is indicated by (B-Bulge, S-Shear, P-Penetrometer)  
The SPT (N value) is the sum of the last two blow values in each sampling zone (AASHTO T206)

BBS, from 137 (Rev. 8-99)

**Illinois Department of Transportation**  
Division of Highways  
Illinois Department of Transportation/D-2

**SOIL BORING LOG**

Page 1 of 1  
Date 5/6/08

ROUTE FA 742 DESCRIPTION P92-064-86 Retaining wall, IL 2, 2.8 m. N. of Mud Creek Road LOGGED BY W. Garza

SECTION 37 RS-3 LOCATION Rockvale Twp. - 10SW, SEC. , TWP. 24N, RNG. 10E

COUNTY Ogle DRILLING METHOD Hollow Stem Auger HAMMER TYPE CME-45 Automatic

STRUCT. NO. \_\_\_\_\_  
Station \_\_\_\_\_

BORING NO. B-14e  
Station 868+00  
Offset 12.00ft Rt CL  
Ground Surface Elev. 681.90 ft

SOIL DESCRIPTION	DEPTH (ft)	BULGE (1/6")	SHEAR (tsf)	PENETRATION (%)	ELEVATION (ft)	TEST TYPE	TEST RESULTS			
							DEPTH (ft)	BULGE (1/6")	SHEAR (tsf)	PENETRATION (%)
LOOSE brown dirty SAND					660.90	DLCS	6	12		
MEDIUM tan fine SAND (continued)	679.90									
	678.40				658.40					
MEDIUM dark brown LOAM		2								
	675.90	4	25.0							
		6			655.90					
MEDIUM tan clean medium coarse SAND										
	673.40				653.40					
STIFF brown SILTY CLAY LOAM		2								
	670.70	3	1.2	28.0						
		4	B		650.90					
MEDIUM tan clean medium coarse SAND with medium GRAVEL										
	668.90									
	668.40									
LOOSE/MEDIUM tan clean medium coarse SAND		1								
	665.90	4								
		6								
	663.40									
MEDIUM tan fine SAND		4								

Surface Water Elev. \_\_\_\_\_ ft  
Stream Bed Elev. \_\_\_\_\_ ft  
Groundwater Elev.:  
First Encounter 670.9 ft ▼  
Upon Completion Wash ft  
After \_\_\_\_\_ Hrs. \_\_\_\_\_ ft

The Unconfined Compressive Strength (UCS) Failure Mode is indicated by (B-Bulge, S-Shear, P-Penetrometer)  
The SPT (N value) is the sum of the last two blow values in each sampling zone (AASHTO T206)

BBS, from 137 (Rev. 8-99)

# BORING LOGS



**Illinois Department of Transportation**  
Division of Highways  
Illinois Department of Transportation/D-2

## SOIL BORING LOG

Page 1 of 1  
Date 5/5/08

ROUTE FA 742 DESCRIPTION P92-064-86 Retaining wall, IL 2, 2.8 m. N. of Mud Creek Road LOGGED BY W. Garza

SECTION 37 RS-3 LOCATION Rockvale Twp. - 10 SW, SEC. , TWP. 24N, RNG. 10E

COUNTY Ogle DRILLING METHOD Hollow Stem Auger HAMMER TYPE B-53 Diedrich Automatic

STRUCT. NO. \_\_\_\_\_  
Station \_\_\_\_\_

BORING NO. B-13e  
Station 874+00  
Offset 13.00ft Rt CL  
Ground Surface Elev. 684.00 ft

SOIL DESCRIPTION	DEPTH (ft)	BULGE (1/6")	SHEAR (tsf)	PENETROMETER (%)	SURFACE WATER ELEV. (ft)	STREAM BED ELEV. (ft)	GROUNDWATER ELEV. (ft)	FIRST ENCOUNTER UPON COMPLETION (ft)	WASH AFTER (ft)	HOURS	DEPTH (ft)	BULGE (1/6")	SHEAR (tsf)	PENETROMETER (%)
LOOSE brown dirty SAND	681.50													
	680.00													
MEDIUM tan fine SAND	677.50	4												
	675.00	6												
	672.50	7												
LOOSE tan clean medium coarse SAND	672.50	2												
	670.00	3												
	667.50	5												
MEDIUM tan clean medium coarse SAND with medium GRAVEL	667.50	9												
	665.00	9												

The Unconfined Compressive Strength (UCS) Failure Mode is indicated by (B-Bulge, S-Shear, P-Penetrometer)  
The SPT (N value) is the sum of the last two blow values in each sampling zone (AASHTO T206)

BBS, from 137 (Rev. 8-99)



**Illinois Department of Transportation**  
Division of Highways  
Illinois Department of Transportation/D-2

## SOIL BORING LOG

Page 1 of 1  
Date 11/30/07

ROUTE FA 742 DESCRIPTION P92-064-86 IL 2 culvert, 1.7 m. S. of Byron LOGGED BY W. Garza

SECTION 37 RS-3 LOCATION Rockvale Twp. - 2 SE, SEC. , TWP. 24N, RNG. 10E

COUNTY Ogle DRILLING METHOD Hollow Stem Auger HAMMER TYPE B-53 Diedrich Automatic

STRUCT. NO. \_\_\_\_\_  
Station \_\_\_\_\_

BORING NO. B-1g  
Station 962+97  
Offset 32.00ft Lt CL  
Ground Surface Elev. 97.50 ft

SOIL DESCRIPTION	DEPTH (ft)	BULGE (1/6")	SHEAR (tsf)	PENETROMETER (%)	SURFACE WATER ELEV. (ft)	STREAM BED ELEV. (ft)	GROUNDWATER ELEV. (ft)	FIRST ENCOUNTER UPON COMPLETION (ft)	WASH AFTER (ft)	HOURS	DEPTH (ft)	BULGE (1/6")	SHEAR (tsf)	PENETROMETER (%)
MEDIUM brown SANDY LOAM	95.50													
	93.50	0.8		14.0										
MEDIUM tan clean dry SAND & GRAVEL	93.50	4												
	91.00	6												
MEDIUM tan clean dry SAND & GRAVEL	91.00	8												
	88.50	12												
MEDIUM tan clean dry SAND & GRAVEL	88.50	8												
	86.00	10												
MEDIUM tan clean medium coarse SAND	86.00	12												
	83.50	7												
MEDIUM tan clean medium coarse SAND	83.50	9												
	81.00	14												
MEDIUM tan clean medium coarse SAND	81.00	9												
	78.50	13												
MEDIUM tan clean medium coarse SAND	78.50	12												
	76.00	8												

The Unconfined Compressive Strength (UCS) Failure Mode is indicated by (B-Bulge, S-Shear, P-Penetrometer)  
The SPT (N value) is the sum of the last two blow values in each sampling zone (AASHTO T206)

BBS, from 137 (Rev. 8-99)

# BORING LOGS



**Illinois Department of Transportation**  
Division of Highways  
Illinois Department of Transportation/D-2

## SOIL BORING LOG

Page 1 of 1  
Date 11/30/07

ROUTE FA 742 DESCRIPTION P92-064-86 IL 2 culvert, 1.7 m. S. of Byron LOGGED BY W. Garza

SECTION 37 RS-3 LOCATION Rockvale Twp. - 2 SE, SEC., TWP. 24N, RNG. 10E

COUNTY Ogle DRILLING METHOD Hollow Stem Auger HAMMER TYPE B-53 Diedrich Automatic

STRUCT. NO. Station	D E P T H	B L O W S	U C S Qu	M O I S T ure	Surface Water Elev.	
					ft	ft
962+86						96.50
BORING NO. <u>B-2g</u> Station <u>962+75</u> Offset <u>38.00ft Rt CL</u> Ground Surface Elev. <u>97.50</u> ft						
MEDIUM brown LOAM			0.9 P	14.0		
MEDIUM brown SANDY LOAM	95.00	3	0.5 P	15.0		
MEDIUM tan clean SANDY GRAVEL	93.00	4 6 8				
DENSE tan clean medium coarse SAND	86.00	11 14 17				
DENSE tan clean dry SAND & GRAVEL	81.00	10 16 25				
MEDIUM tan clean dry medium SAND	78.50	9 9 10				
End of Boring	-20					

The Unconfined Compressive Strength (UCS) Failure Mode is indicated by (B-Bulge, S-Shear, P-Penetrometer)  
The SPT (N value) is the sum of the last two blow values in each sampling zone (AASHTO T206)

BBS, from 137 (Rev. 8-99)



**Illinois Department of Transportation**  
Division of Highways  
Illinois Department of Transportation/D-2

## SOIL BORING LOG

Page 1 of 1  
Date 4/1/08

ROUTE FA 742 DESCRIPTION P92-064-86 Box culvert on IL 2, .2 m. N. of River Drive LOGGED BY W. Garza

SECTION 37 RS-3 LOCATION SEC., TWP., RNG.

COUNTY Ogle DRILLING METHOD Hollow Stem Auger HAMMER TYPE B-53 Diedrich Automatic

STRUCT. NO. Station	D E P T H	B L O W S	U C S Qu	M O I S T ure	Surface Water Elev.	
					ft	ft
982+50						
BORING NO. <u>B-2i</u> Station <u>982+00</u> Offset <u>14.00ft Lt of CL</u> Ground Surface Elev. <u>99.20</u> ft						
Off Road			1.1 P	22.0		
STIFF brown SILTY CLAY LOAM	77.70					
MEDIUM brown SILTY CLAY	96.70	1 2 3	0.5 B	26.0		
LOOSE brown dirty fine SAND	95.20	3 6	0.5 P	21.0		
LOOSE tan/brown fine SAND	92.20	1 1 8				
MEDIUM tan dry fine SAND	90.20	8 10 13				
MEDIUM tan dry fine SAND	87.70	8 11 13				
MEDIUM tan dry fine SAND	85.20	7 9 12				
DENSE tan dry SANDY GRAVEL	80.20	6 21 28				
End of Boring	67.70					

The Unconfined Compressive Strength (UCS) Failure Mode is indicated by (B-Bulge, S-Shear, P-Penetrometer)  
The SPT (N value) is the sum of the last two blow values in each sampling zone (AASHTO T206)

BBS, from 137 (Rev. 8-99)

# BORING LOGS

**Illinois Department of Transportation**  
Division of Highways  
Illinois Department of Transportation/D-2

**SOIL BORING LOG**

Page 1 of 1  
Date 4/1/08

ROUTE FA 742 DESCRIPTION P92-064-86 Box culvert on IL 2, .2 m. N. of River Drive LOGGED BY W. Garza

SECTION 37 RS-3 LOCATION SEC. , TWP. , RNG.

COUNTY Ogle DRILLING METHOD Hollow Stem Auger HAMMER TYPE B-53 Diedrich Automatic

STRUCT. NO. \_\_\_\_\_  
Station 982+47

BORING NO. B-1j  
Station 982+50  
Offset 13.00ft Rt CL  
Ground Surface Elev. 100.60 ft

DEPTH	SOIL DESCRIPTION	DRILLING METHOD	HAMMER TYPE	Surface Water Elev. (ft)	Stream Bed Elev. (ft)	Groundwater Elev. (ft)	First Encounter (ft)	Upon Completion (ft)	After (Hrs)
Off Road									
	MEDIUM brown SILTY CLAY LOAM								
98.10									
	STIFF brown LOAM								
96.60									
	SOFT brown SANDY LOAM with SAND lens								
93.60									
	LOOSE brown dirty fine SAND								
91.60									
	MEDIUM tan fine SAND								
89.10									
	VERY DENSE tan dry SANDY GRAVEL								
86.60									
	VERY DENSE tan dry SANDY GRAVEL								
84.10									
	End of Boring								

The Unconfined Compressive Strength (UCS) Failure Mode is indicated by (B-Bulge, S-Shear, P-Penetrometer)  
The SPT (N value) is the sum of the last two blow values in each sampling zone (AASHTO T206)

BBS, from 137 (Rev. 8-99)

**Illinois Department of Transportation**  
Division of Highways  
Illinois Department of Transportation/D-2

**SOIL BORING LOG**

Page 1 of 1  
Date 6/16/09

ROUTE FA 742 DESCRIPTION P92-064-86 IL 2 Retaining Wall, .4 m. N. of Townline Road LOGGED BY W. Garza

SECTION 37 RS-3 LOCATION Byron Twp. - 36SW, SEC. , TWP. 25N, RNG. 10E

COUNTY Ogle DRILLING METHOD Hollow Stem Auger HAMMER TYPE CME-45 Automatic

STRUCT. NO. \_\_\_\_\_  
Station \_\_\_\_\_

BORING NO. B-1j  
Station 1032+00  
Offset 19.00ft Rt CL  
Ground Surface Elev. 686.90 ft

DEPTH	SOIL DESCRIPTION	DRILLING METHOD	HAMMER TYPE	Surface Water Elev. (ft)	Stream Bed Elev. (ft)	Groundwater Elev. (ft)	First Encounter (ft)	Upon Completion (ft)	After (Hrs)
	SOFT dark brown SILTY CLAY LOAM								
684.90									
	STIFF brown SILTY CLAY LOAM								
683.40									
	SOFT brown SILTY CLAY LOAM								
680.40									
	MEDIUM tan weathered LIMESTONE								
678.40									
	VERY DENSE tan weathered LIMESTONE								
675.90									
	VERY DENSE gray SANDSTONE								
673.40									
	DENSE tan weathered LIMESTONE								
670.90									
	VERY DENSE tan weathered LIMESTONE								
668.40									

The Unconfined Compressive Strength (UCS) Failure Mode is indicated by (B-Bulge, S-Shear, P-Penetrometer)  
The SPT (N value) is the sum of the last two blow values in each sampling zone (AASHTO T206)

BBS, from 137 (Rev. 8-99)



# BORING LOGS



**Illinois Department of Transportation**  
Division of Highways  
Illinois Department of Transportation/D-2

## SOIL BORING LOG

Page 1 of 1  
Date 6/17/09

ROUTE FA 742 DESCRIPTION P92-064-86 IL 2 Retaining Wall, .4 m. N. of Townline Road LOGGED BY W. Garza

SECTION 37 RS-3 LOCATION Byron Twp. - 36SW, SEC. , TWP. 25N, RNG. 10E

COUNTY Ogle DRILLING METHOD Hollow Stem Auger HAMMER TYPE CME-45 Automatic

STRUCT. NO.	D E P T H	B L O W S	U C S	M O I S T U R E	Surface Water Elev.				
					ft	ft			
BORING NO. <u>B-7j</u>	<u>1035+00</u>	<u>18.00ft Rt CL</u>	<u>687.50</u> ft	<u>(ft)</u>	<u>(/6")</u>	<u>(tsf)</u>	<u>(%)</u>	Groundwater Elev.:	
Station								First Encounter	ft
Offset								Upon Completion	ft
Ground Surface Elev.								After	Hrs.

Soil Description	Depth (ft)	Blows (/6")	UCS (tsf)	Moisture (%)
MEDIUM dark brown SILTY CLAY LOAM	685.50	2	0.9 P	27.0
MEDIUM brown SILTY CLAY LOAM	684.00	5	0.9 P	29.0
STIFF brown SILTY CLAY LOAM	681.50	4	1.2 B	27.0
VERY SOFT light brown SILTY LOAM	678.50	2	0.2 B	27.0
VERY DENSE tan weathered LIMESTONE	677.50	-10	100/6.5"	
End of Boring				

The Unconfined Compressive Strength (UCS) Failure Mode is indicated by (B-Bulge, S-Shear, P-Penetrometer)  
The SPT (N value) is the sum of the last two blow values in each sampling zone (AASHTO T206)

BBS, from 137 (Rev. 8-99)



**Illinois Department of Transportation**  
Division of Highways  
Illinois Department of Transportation/D-2

## SOIL BORING LOG

Page 1 of 1  
Date 6/17/09

ROUTE FA 742 DESCRIPTION P92-064-86 IL 2 Retaining Wall, .4 m. N. of Townline road LOGGED BY W. Garza

SECTION 37 RS-3 LOCATION Byron Twp. - 36SW, SEC. , TWP. 25N, RNG. 10E

COUNTY Ogle DRILLING METHOD Hollow Stem Auger HAMMER TYPE CME-45 Automatic

STRUCT. NO.	D E P T H	B L O W S	U C S	M O I S T U R E	Surface Water Elev.				
					ft	ft			
BORING NO. <u>B-10j</u>	<u>1036+05</u>	<u>18.00ft Rt CL</u>	<u>686.90</u> ft	<u>(ft)</u>	<u>(/6")</u>	<u>(tsf)</u>	<u>(%)</u>	Groundwater Elev.:	
Station								First Encounter	ft
Offset								Upon Completion	ft
Ground Surface Elev.								After	Hrs.

Soil Description	Depth (ft)	Blows (/6")	UCS (tsf)	Moisture (%)
MEDIUM brown SILTY CLAY LOAM	684.90	3	0.7 P	27.0
STIFF brown SILTY CLAY LOAM	683.40	4	1.1 B	27.0
SOFT brown SILTY LOAM	680.90	2	0.3 B	30.0
VERY DENSE tan weathered LIMESTONE	677.90	-10	100/6.5"	
Auger Refusal	675.40			
End of Boring				

The Unconfined Compressive Strength (UCS) Failure Mode is indicated by (B-Bulge, S-Shear, P-Penetrometer)  
The SPT (N value) is the sum of the last two blow values in each sampling zone (AASHTO T206)

BBS, from 137 (Rev. 8-99)

FILE NAME =	USER NAME = grantpm	DESIGNED -	REVISED -	<b>STATE OF ILLINOIS DEPARTMENT OF TRANSPORTATION</b>	<b>BORING LOGS</b>	F.A.P RTE.	SECTION	COUNTY	TOTAL SHEETS	SHEET NO.	
cr:\pw_work\PWIDOT\GRANTPM\dms31213\086681logs.dgn		DRAWN -	REVISED -			742	37R-4	Ogle	867	439	
PLOT SCALE = 1/8" = 1'-0"		CHECKED -	REVISED -			CONTRACT NO. 64E17					
PLOT DATE = Tue Mar 30 09:31:37 2010		DATE -	REVISED -			FED. ROAD DIST. NO. ILLINOIS FED. AID PROJECT					

# STANDARD INLET FOR CURB & GUTTER TYPE M-4.24

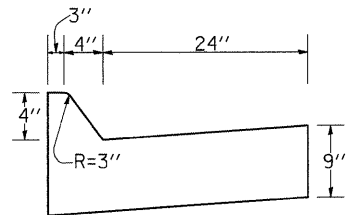
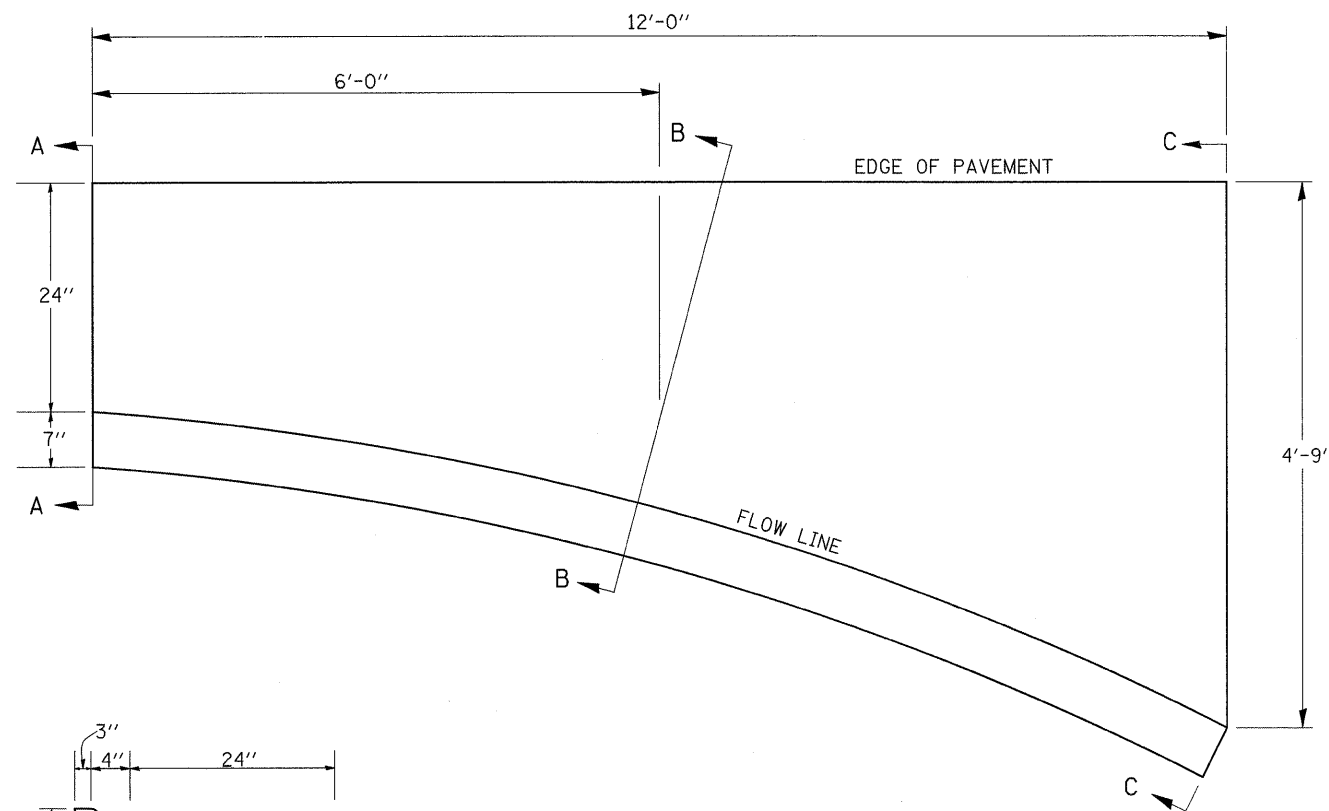

SECTION A-A

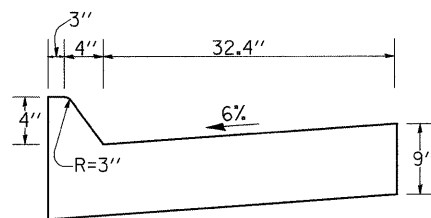

SECTION B-B

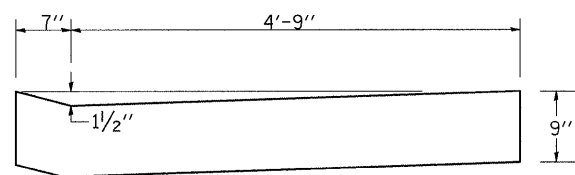

SECTION C-C

### NOTES

Class SI Concrete shall be used throughout.

The Curb and Gutter Inlet will be paid for at the contract unit price per cubic yard for Class SI Concrete (OUTLETS).

Joints shall be constructed in accordance with the requirements of Article 606.07 of the Standard Specifications.

When curb and gutter is constructed adjacent to flexible pavement, a 1" expansion joint shall be installed at construction joints.

- QUANTITY -

Section A-A to C-C  
(1.20 Cu. Yds.)  
Class SI Concrete

# DETAIL OF SHOULDER AT GUARDRAIL

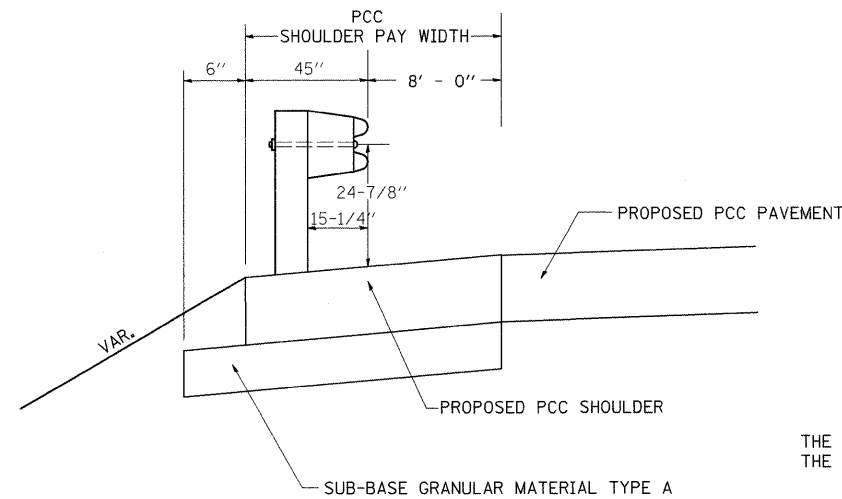

### GENERAL NOTES

THE HEIGHT OF THE GUARD RAIL SHALL BE SET 24 7/8 INCHES FROM THE FINISHED SURFACE.

# DETAIL OF SHOULDER AT GUARDRAIL

# DRAIN FOR AGGREGATE BASE COURSE

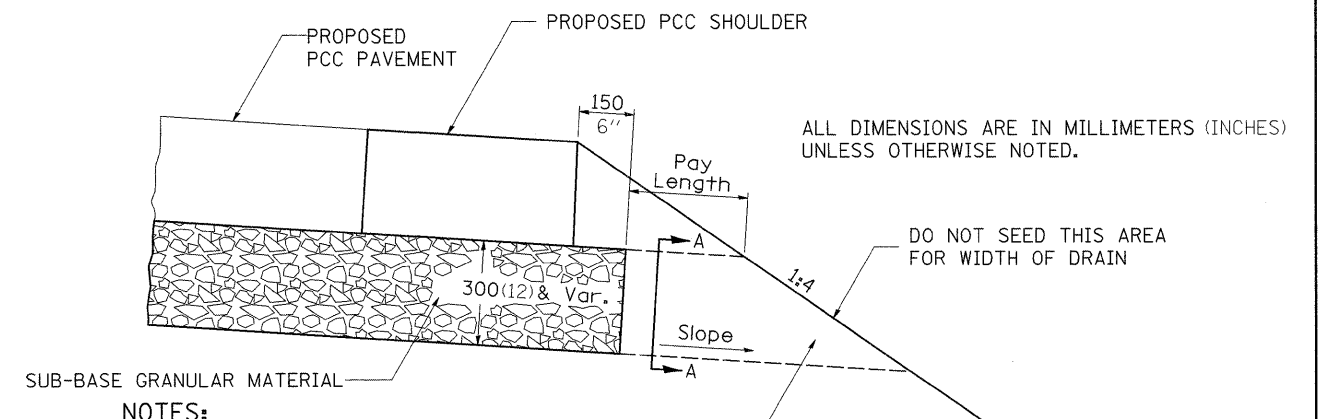

### NOTES:

The rock outlets shall be constructed using CA7 and will be paid for at the contract unit price per m<sup>2</sup> (SQ. YD.) for DRAIN FOR AGGREGATE BASE COURSE. The thickness shall be the same as the adjacent sub-base material as noted on the plans and shall include the cost of the filter fabric. The Rock outlets will be measured in m<sup>2</sup> (SQ. YD.), the width being 900 (36) by the length shown above. The cost of the CA6 or CA10 under the shoulder shall be included in the contract unit price per m<sup>2</sup> (SQ. YD.) for SUB-BASE GRANULAR MATERIAL, TYPE A of the thickness specified. The filter fabric to be used shall conform to the filter fabric used for Riprap.

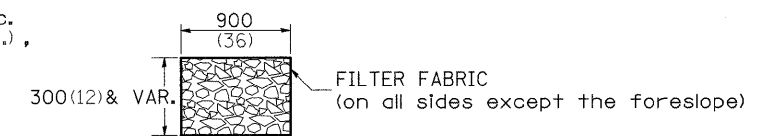

SECTION A-A

NOTE: Slope same as shoulder with 2% min.

FILE NAME =	USER NAME = grantpm	DESIGNED -	REVISED -	<b>STATE OF ILLINOIS DEPARTMENT OF TRANSPORTATION</b>	<b>SPECIAL DETAILS</b>	F.A.P. RTE.	SECTION	COUNTY	TOTAL SHEETS	SHEET NO.
ct:\pwwork\pwidot\GRANTPM\dms31213\d06608apl.dgn	PLOT SCALE = 50.0000' / IN.	DRAWN -	REVISED -			742	3TR-4	OGLE	867	440
PLOT DATE = Tue Mar 30 09:21:57 2010	DATE -	CHECKED -	REVISED -			CONTRACT NO. 64E17				
		DATE -	REVISED -			FED. ROAD DIST. NO. ILLINOIS FED. AID PROJECT				
						SCALE:	SHEET NO. 1 OF 2 SHEETS	STA.	TO STA.	



# SUPERELEVATION TRANSITION

TRANSITION CURVE TABLE

CURVE PI STATION	SUPERELEVATION "e" %	W FOOT	SUPERELEVATION TRANSITION LENGTH FOOT	TANGENT RUNOUT DISTANCE FOOT	SUPERELEVATION RUNOFF LENGTH FOOT	
682+45.19	5.4	12	P. C. 242 P. T. 177	P. C. 35 P. T. 39	P. C. 207 P. T. 138	
694+01.44	1.9	12	P. C. 86 P. T. 94	P. C. 38	P. C. 48 P. T. 94 ROTATION AT STA. 697+04.06	
703+43.20	3.3	12	P. C. 147 P. T. 122	P. C. 38	P. C. 147 ROTATION AT STA. 697+04.06 P. T. 84	
719+72.11	5.6	12	P. C. 186 P. T. 107	P. C. 39	P. C. 147 P. T. 107 HOLD RC 1.5% FROM STA. 725+48.63 TO 728+09.62	
727+71.83	R.C.	12	P. T. 78	P. T. 39	P.C. HOLD RC 1.5% FROM STA. 725+48.63 TO 728+09.62 P. T. 39	
745+42.65	2.4	12	P. C. 102	P. C. 39	P. C. 63 P.C.C. HOLD 2.4% SUPERELEVATION	
759+30.94	2.4	12	P. T. 102	P. T. 39	P.C.C. HOLD 2.4% SUPERELEVATION P. T. 63	
776+28.99	4.4	12	P. C. 149 P. T. 226	P. C. 38 P. T. 58	P. C. 111 P. T. 168	
805+53.73	3.1	12	P. C. 178 P. T. 120	P. C. 58 P. T. 39	P. C. 120 P. T. 81	
820+26.92	5.6	12	P. C. 183 P. T. 183	P. C. 39	P. C. 144 P. T. 183 ROTATION AT STA. 826+51.65	
833+30.82	3.9	12	P. C. 138 P. T. 208	P. T. 58	P. C. 138 ROTATION AT STA. 826+51.65 P. T. 150	
854+53.48	4.1	12	P. C. 217 P. T. 143	P. C. 58 P. T. 38	P. C. 159 P. T. 105	
869+73.50	4.9	12	165	39	126	
879+55.96	5.4	12	P. C. 177 P. T. 198	P. C. 39	P. C. 138 P. T. 198 ROTATION AT STA. 883+81.19	
886+25.97	3.1	12	P. C. 141 P. T. 120	P. T. 39	P. C. 141 ROTATION AT STA. 883+81.19 P. T. 81	
908+48.83	4.9	12	165	39	126	
936+92.35	4.0	12	211	58	153	
975+33.17	5.4	12	P. C. 269 P. T. 300	P. C. 59	P. C. 210 P. T. 300 ROTATION AT STA. 981+05.87	
986+85.60	5.4	12	P. C. 198 P.C.C. 59		P. C. 198 ROTATION AT STA. 981+05.87 P.C.C. 59 TRANSITION FROM 5.4% TO 3.1% STA. 990+82.98 TO 991+41.98	
995+36.56	3.1	12	P.C.C. 59 P. T. 120	P. T. 39	P.C.C. 59 TRANSITION FROM 5.4% TO 3.1% STA. 990+82.98 TO 991+41.98 P. T. 81	
1006+13.41	3.9	12	P. C. 141 P. T. 208	P. C. 39 P. T. 58	P. C. 102 P. T. 150	
1037+32.46	NC	12	NA	NA	NA	
1049+21.81	NC	12	NA	NA	NA	
1061+00.26	5.8	12	189	39	150	

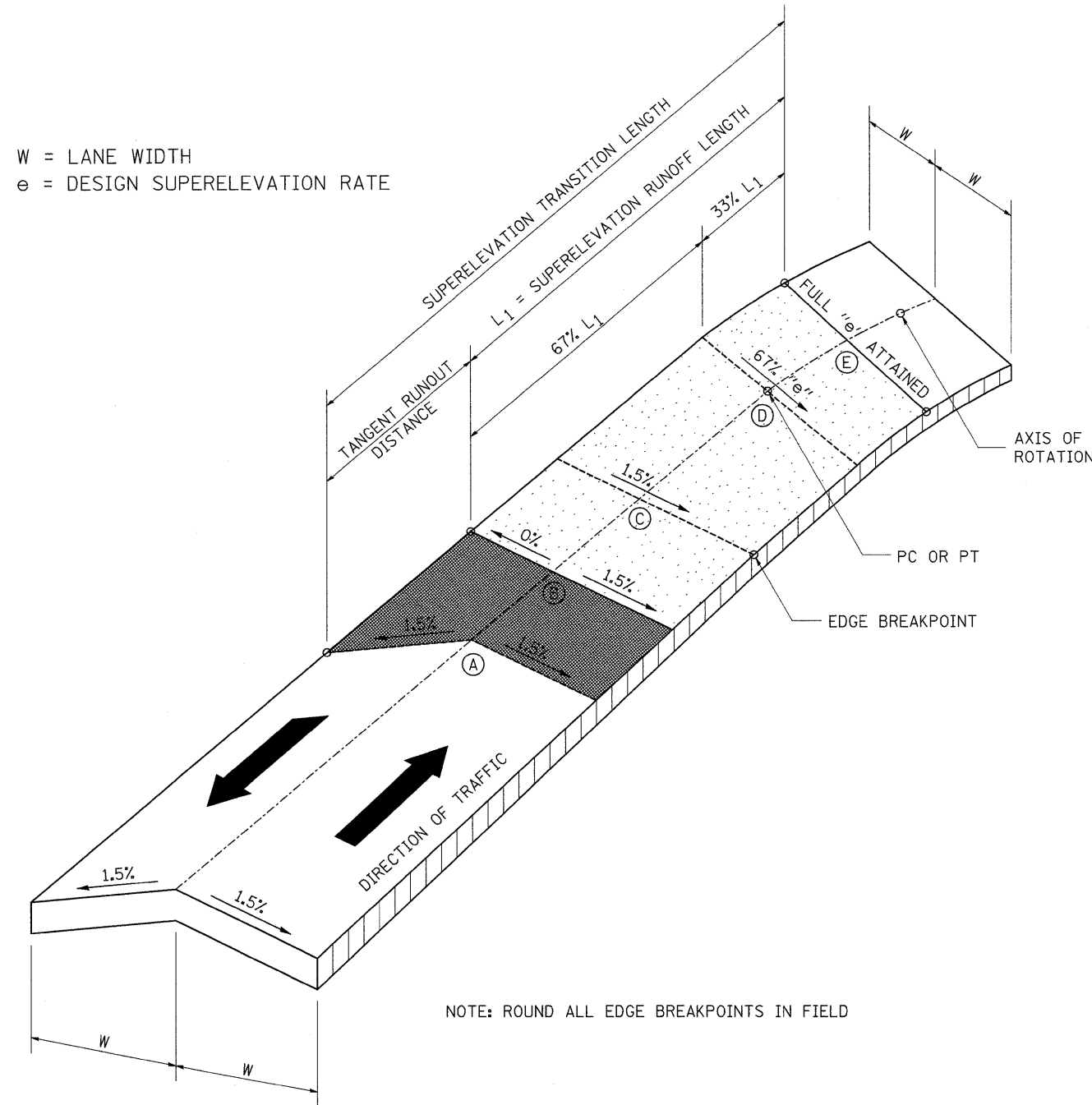

W = LANE WIDTH  
e = DESIGN SUPERELEVATION RATE

NOTE: ROUND ALL EDGE BREAKPOINTS IN FIELD

FILE NAME =	USER NAME = grantpm	DESIGNED -	REVISED -
c:\pwork\PWIDOT\GRANTPM\dms31213\08688sp1.dgn		DRAWN -	REVISED -
PLOT SCALE = 50.0000' / IN.		CHECKED -	REVISED -
PLOT DATE = Tue Mar 30 09:21:58 2010		DATE -	REVISED -

STATE OF ILLINOIS  
DEPARTMENT OF TRANSPORTATION

## SUPERELEVATION TRANSITION

SCALE: STA. TO STA.

F.A.P. RTE. 742	SECTION 37R-4	COUNTY OGLE	TOTAL SHEETS 867	SHEET NO. 441
FED. ROAD DIST. NO. [ILLINOIS] FED. AID PROJECT CONTRACT NO. 64E17				

SUPERELEVATION TRANSITION

# ENTRANCES AND SIDEROADS WITH 8' PCC SHOULDERS

7.2m (24') FIELD ENTRANCE		
	APRON	PER ADDITIONAL METER (LIN FT) ENTR
AGG BASE CSE T-B M TON (TON)	18.9 (21.9)	3.5 (1.2)

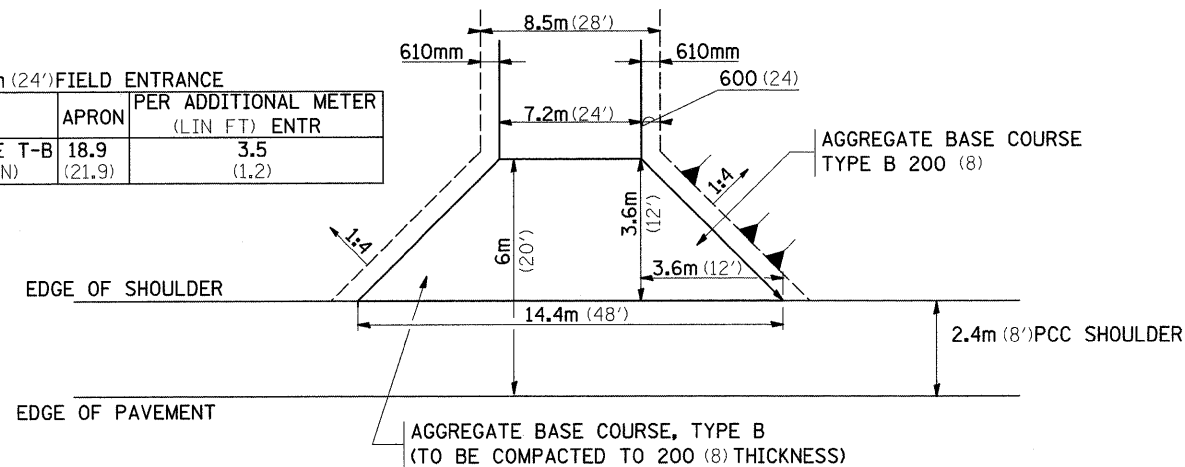

**FIELD ENTRANCE**

	COMMERCIAL ENTRANCE		PER METER ENTR (FOOT)	
	3.6m (12')	10.5m (35')	3.6m (12')	10.5m (35')
AGG BASE CSE T-B (TON)	14.3 (15.8)	27.0 (29.8)	0.64 (0.70)	1.70 (1.87)
INC HMA SURF 50 (2) (TON)	3.3 (3.6)	6.35 (7.0)	0.14 (0.15)	0.40 (0.44)
BIT PRIME COAT (TON)	0.042 (0.046)	0.082 (0.090)	0.002 (0.002)	0.005 (0.006)

**NOTE**

- ① ALL PE & CE ARE TO BE INCIDENTAL HOT-MIX ASPHALT SURFACED TO RIGHT OF WAY LINE. AREA BEHIND RIGHT OF WAY SHALL MATCH EXISTING SURFACE.
- ② FE ARE TO BE AGGREGATE TO RIGHT OF WAY OR TOUCH DOWN, WHICH EVER IS GREATEST.
- ③ QUANTITIES ARE CALCULATED WITH 2.4M (8') PCC SHOULDER IN PLACE. AGGREGATE QUANTITIES SHOWN ARE FOR NEW CONSTRUCTION.
- ④ EXCAVATION REQUIRED FOR PLACEMENT OF AGGREGATE BASE COURSE SHALL BE CONSIDERED INCLUDED TO THE AGGREGATE BASE COURSE.
- ⑤ ALL DIMENSIONS ARE IN MILLIMETERS (INCHES) UNLESS OTHERWISE NOTED.
- ⑥ SEE PAVEMENT JOINT DETAILS, PAVEMENT ELEVATION DETAILS, AND TYPICALS FOR ALL SIDEROAD LIMITS AND DIMENSIONS.

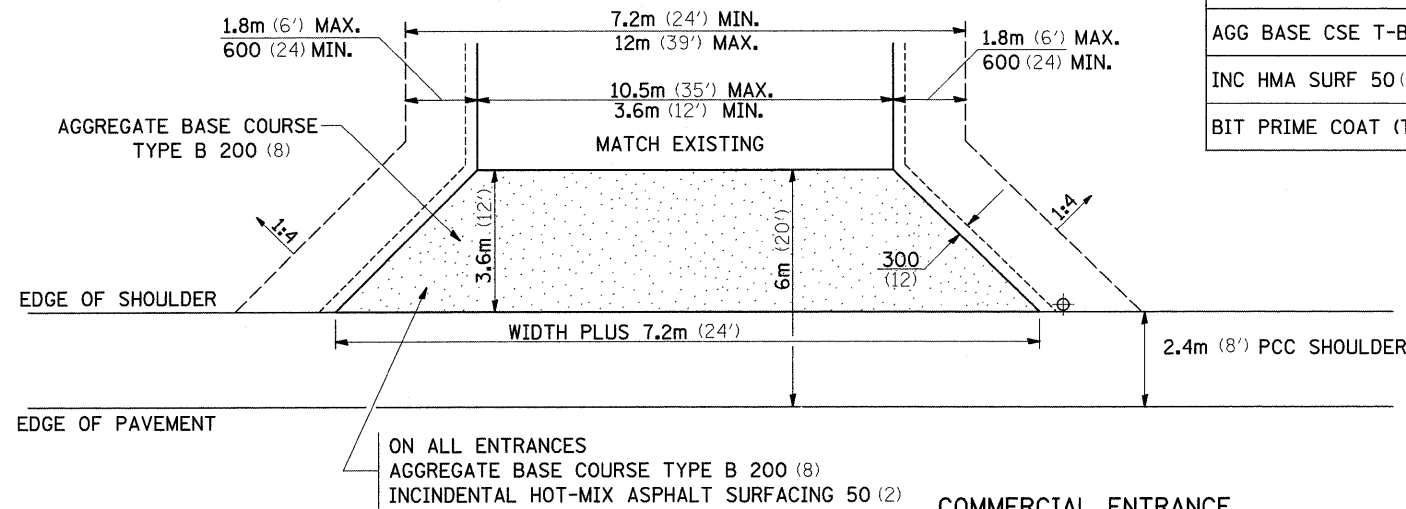

**COMMERCIAL ENTRANCE**

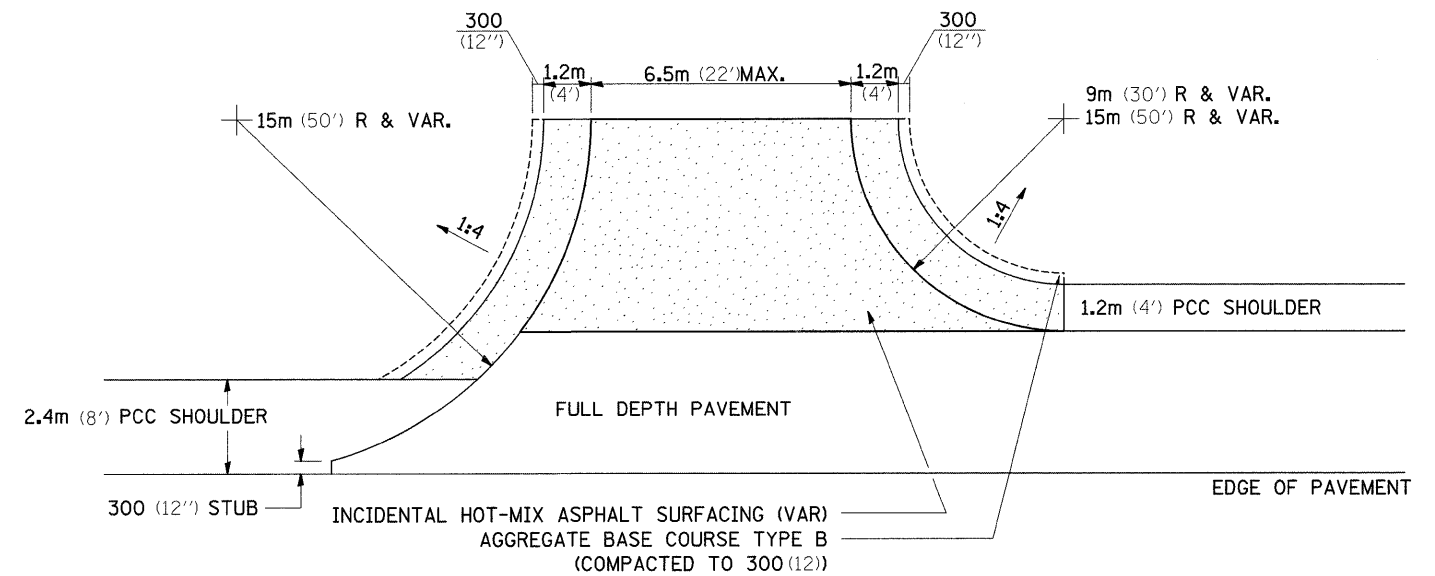

**SIDEROAD RETURN (SEE NOTE 6)**

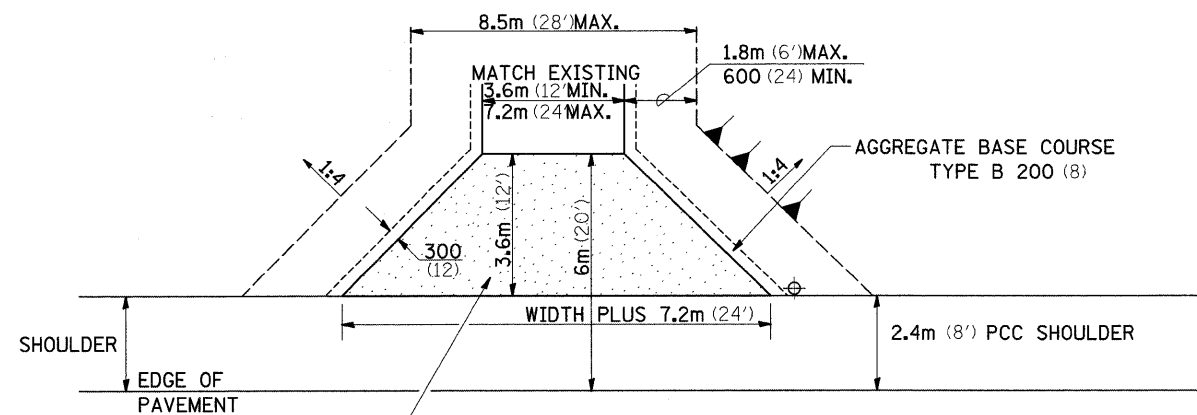

**PRIVATE ENTRANCE**

	3.6m (12') PRIVATE ENTRANCE		PER METER ENTR (FOOT)	
	3.6m (12')	7.2m (24')	3.6m (12')	7.2m (24')
AGG BASE CSE T-B (TON)	14.3 (15.8)	21.0 (23.1)	0.64 (0.70)	1.20 (1.32)
INC HMA SURF 50 (2) (TON)	3.3 (3.6)	4.9 (5.4)	0.14 (0.15)	0.27 (0.30)
BIT PRIME COAT (TON)	0.042 (0.046)	0.063 (0.069)	0.002 (0.002)	0.004 (0.004)

FILE NAME =	USER NAME = grantpm	DESIGNED -	REVISED - 1-15-08
ct\pw_work\FWIDOT\GRANTPM\dms31213\d06620sp1.dgn		DRAWN -	REVISED -
PLOT SCALE = 50.0000' / IN.		CHECKED -	REVISED -
PLOT DATE = Tue Mar 30 09:22:00 2010		DATE -	REVISED -

**STATE OF ILLINOIS  
DEPARTMENT OF TRANSPORTATION**

**ENTRANCES AND SIDEROADS  
WITH 8' PCC SHOULDERS**

F.A.P. RTE.	SECTION	COUNTY	TOTAL SHEETS	SHEET NO.
742	37R-4	OGLE	867	442
CONTRACT NO. 64E17				
FED. ROAD DIST. NO. ILLINOIS FED. AID PROJECT				

SCALE: SHEET NO. OF SHEETS STA. TO STA.

**ENTRANCES AND SIDEROADS WITH 8' PCC SHOULDERS**

# EXISTING BRIDGE APPROACH PAVEMENT DETAIL

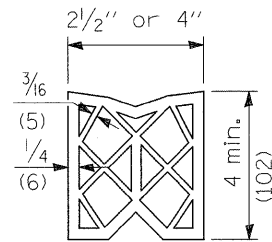
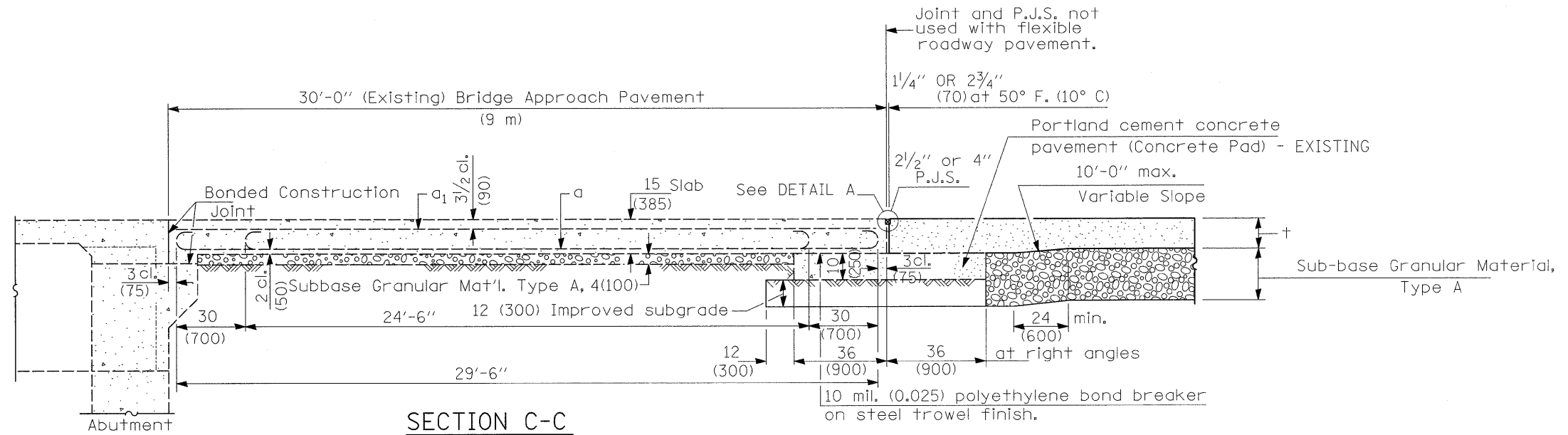

PREFORMED JOINT SEAL

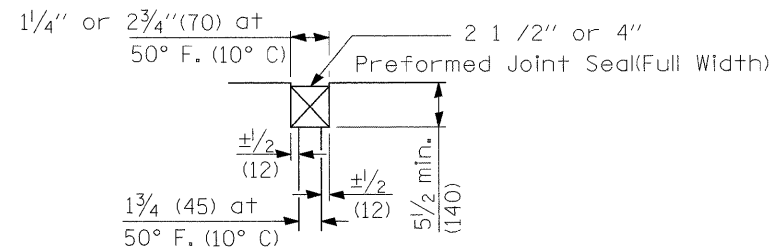

DETAIL A

**"FOR INFORMATION ONLY"**

(SEE SCHEDULE FOR LOCATIONS)

FILE NAME =	USER NAME = grantpm	DESIGNED -	REVISED -	<b>STATE OF ILLINOIS DEPARTMENT OF TRANSPORTATION</b>	<b>EXISTING BRIDGE APPROACH PAVEMENT DETAIL</b>	F.A.P. RTE. 742	SECTION 37R-4	COUNTY OGLE	TOTAL SHEETS 867	SHEET NO. 443	
ct:\pw_work\pwidot\GRANTPM\dms31213\d06628ep1.dgn	PLOT SCALE = 50,0000 ' / IN.	DRAWN -	REVISED -			SCALE:	SHEET NO. OF SHEETS	STA. TO STA.	CONTRACT NO. 64E17		
	PLOT DATE = Tue Mar 30 09:22:01 2010	CHECKED -	REVISED -			ILLINOIS FED. AID PROJECT					
		DATE -	REVISED -								

# OUTLET FOR CURB & GUTTER TYPE M-4.24

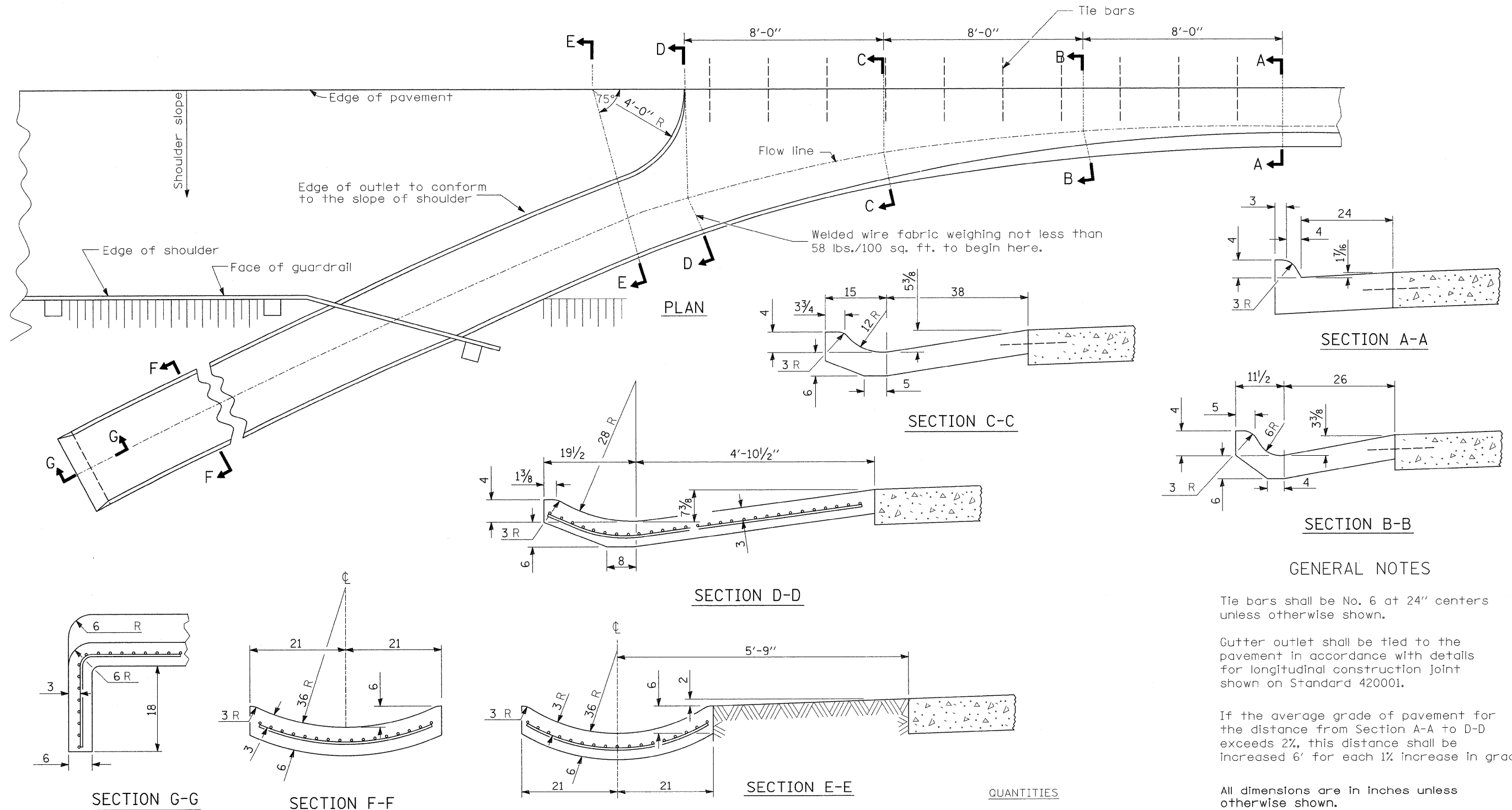

### GENERAL NOTES

Tie bars shall be No. 6 at 24" centers unless otherwise shown.

Gutter outlet shall be tied to the pavement in accordance with details for longitudinal construction joint shown on Standard 420001.

If the average grade of pavement for the distance from Section A-A to D-D exceeds 2%, this distance shall be increased 6' for each 1% increase in grade.

All dimensions are in inches unless otherwise shown.

### QUANTITIES

For Section A-A to E-E and curtain wall = 2.40 cu. yds. concrete for 9 1/2 pav't.

For Section F-F = 0.069 cu. yds. concrete per ft.

FILE NAME =	USER NAME = grantpm	DESIGNED -	REVISED -	<b>STATE OF ILLINOIS DEPARTMENT OF TRANSPORTATION</b>	<b>OUTLET FOR CURB &amp; GUTTER TYPE M-4.24</b>	F.A.P. RTE.	SECTION	COUNTY	TOTAL SHEETS	SHEET NO.	
ca\pwork\pwork\GRANTPM\dms31213\006888ap1.dgn	PLOT SCALE = 50.0000' / IN.	DRAWN -	REVISED -			742	37R-4	OGLE	867	444	
	PLOT DATE = Tue Mar 30 09:22:01 2010	CHECKED -	REVISED -			SCALE: SHEET NO. 1 OF 2 SHEETS STA. TO STA.		FED. ROAD DIST. NO. ILLINOIS FED. AID PROJECT CONTRACT NO. 64E17			
		DATE -	REVISED -								

# GUTTER WARPING DETAIL

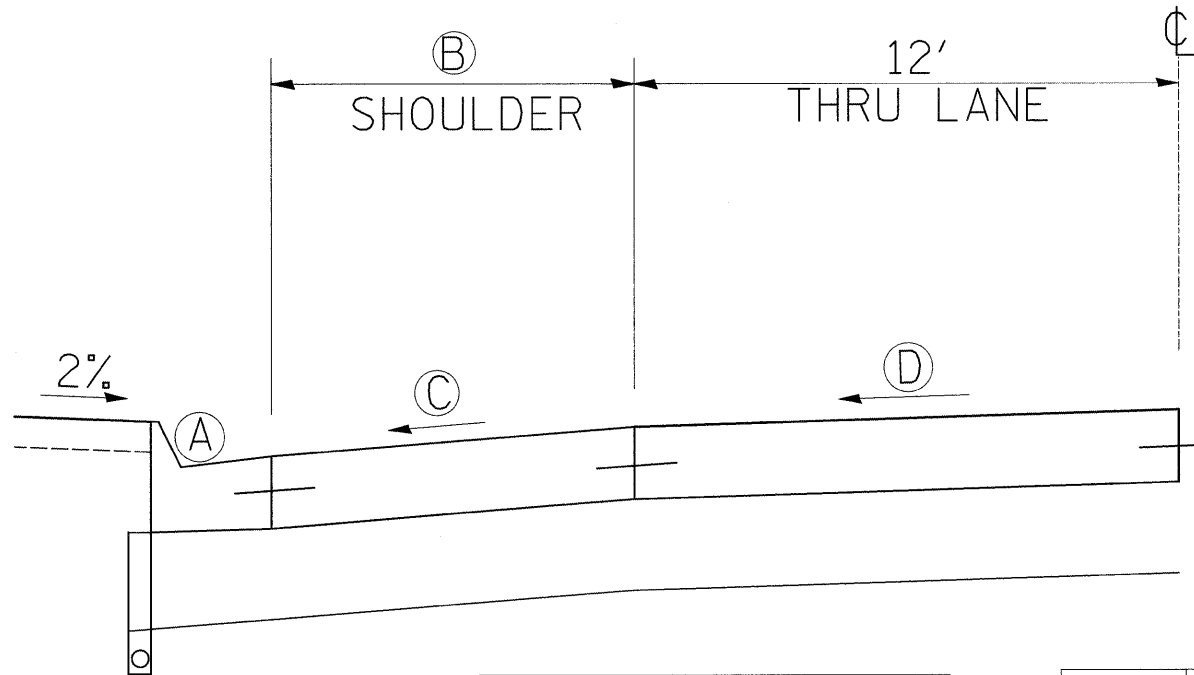

STA	A GUTTER ELEV	B SHLDR WIDTH	C SHLDR SLOPE	D LN SLOPE
680+00	NA	4.0	-5.40	-5.40
680+50	678.377	4.0	-4.00	-5.40
681+00	678.536	4.4	-3.00	-5.40
681+50	678.734	7.1	-2.00	-5.40
682+00	678.567	8.0	-5.40	-5.40
682+50	678.714	8.0	-4.00	-5.40
683+00	678.852	8.0	-3.00	-5.40
683+50	678.669	8.0	-6.00	-5.40
684+00	678.807	8.0	-5.00	-5.40
684+50	678.945	8.0	-4.00	-5.40
685+00	679.082	8.0	-3.00	-5.40
685+50	678.948	8.0	-5.40	-5.40
686+00	679.267	8.0	-4.36	-4.36
686+50	679.516	8.0	-4.00	-3.26
687+00	679.709	8.0	-4.00	-2.16
687+50	679.974	8.0	-2.00	-1.50
688+00	679.823	8.0	-4.00	-1.50
688+50	679.976	8.0	-2.00	-1.50
689+00	679.806	8.0	-4.00	-1.50
689+50	679.636	8.0	-6.00	-1.50
690+00	679.787	8.0	-4.00	-1.50
690+50	679.937	8.0	-2.00	-1.50
691+00	679.762	8.0	-4.00	-1.54
691+50	679.564	8.0	-6.00	-1.77
692+00	679.699	8.0	-4.00	-1.90
692+50	679.849	8.0	-2.00	-1.90
693+00	679.679	8.0	-4.00	-1.90
693+50	679.509	8.0	-6.00	-1.90
694+00	679.659	8.0	-4.00	-1.90
694+50	679.809	8.0	-2.00	-1.90
695+00	679.639	8.0	-4.00	-1.90
695+50	679.469	8.0	-6.00	-1.90
696+00	679.619	8.0	-4.00	-1.90
696+50	679.867	8.0	-2.00	-1.09
697+00	679.658	8.0	-6.00	-0.08
697+50	679.941	8.0	-4.00	1.03
698+00	680.066	8.0	-4.00	2.15
698+50	680.351	8.0	-2.00	3.27
699+00	680.184	8.0	-4.00	3.30
699+50	680.334	8.0	-2.00	3.30
700+00	680.164	8.0	-4.00	3.30
700+50	680.314	8.0	-2.00	3.30
701+00	680.144	8.0	-4.00	3.30
701+50	680.294	8.0	-2.00	3.30
702+00	680.124	8.0	-4.00	3.30
702+50	680.275	8.0	-2.00	3.30
703+00	680.105	8.0	-4.00	3.30
703+50	680.255	8.0	-2.00	3.30

STA	A GUTTER ELEV	B SHLDR WIDTH	C SHLDR SLOPE	D LN SLOPE
704+00	680.085	8.0	-4.00	3.30
704+50	680.235	8.0	-2.00	3.30
705+00	680.065	8.0	-4.00	3.30
705+09	680.063	8.0	-4.00	3.30
705+50	680.215	8.0	-2.00	3.30
706+00	680.045	8.0	-4.00	3.30
706+50	680.195	8.0	-2.00	3.30
707+00	680.025	8.0	-4.00	3.30
707+50	680.175	8.0	-2.00	3.30
708+00	680.005	8.0	-4.00	3.30
708+50	680.155	8.0	-2.00	3.30
709+00	679.732	8.0	-4.00	1.19
709+50	679.458	8.0	-4.00	-1.02
710+00	679.230	8.0	-6.00	-1.50
710+50	679.563	8.0	-2.00	-1.50
711+00	679.304	8.0	-6.00	-1.50
711+50	679.573	8.0	-4.00	-1.50
712+00	679.728	8.0	-4.00	-1.50
712+50	679.931	8.0	-4.00	-1.50
713+00	680.360	8.0	-4.00	-0.01
713+50	680.886	8.0	-4.00	1.89
714+00	681.458	8.0	-2.00	3.80
714+50	682.228	8.0	-2.40	5.60
715+00	682.716	8.0	-2.40	5.60
715+50	683.236	8.0	-2.40	5.60
716+00	683.804	8.0	-2.40	5.60
716+05	NA	8.0	-2.40	5.60

STA	A GUTTER ELEV	B SHLDR WIDTH	C SHLDR SLOPE	D LN SLOPE
726+50	684.429	4.0	-4.00	-2.00
727+00	684.144	4.0	-4.00	-2.00
727+50	683.862	4.0	-4.00	-2.00
728+00	683.688	4.0	-4.00	-2.00
728+50	683.335	5.3	-4.00	-0.05
729+00	682.909	7.9	-4.00	-1.50
729+50	682.590	8.0	-6.00	-1.50
730+00	682.790	8.0	-2.00	-1.50
730+50	682.530	8.0	-4.00	-1.50
731+00	682.300	8.0	-6.00	-1.50
731+50	682.580	8.0	-2.00	-1.50
732+00	682.410	8.0	-4.00	-1.50
732+50	682.259	8.0	-6.00	-1.50
733+00	682.466	8.0	-4.00	-1.50
733+50	682.604	8.0	-3.00	-1.50
734+00	682.423	8.0	-6.00	-1.50
734+50	682.641	8.0	-4.00	-1.50
735+00	682.780	8.0	-3.00	-1.50
735+50	682.598	8.0	-6.00	-1.50
736+00	682.817	8.0	-4.00	-1.50
736+50	682.955	8.0	-3.00	-1.50
737+00	682.774	8.0	-6.00	-1.50
737+50	682.993	8.0	-4.00	-1.50
738+00	683.253	8.0	-4.00	0.18
738+50	683.421	8.0	-5.50	2.09
739+00	683.636	8.0	-4.00	2.40
739+50	683.775	8.0	-3.00	2.40
740+00	683.633	8.0	-5.50	2.40
740+50	683.812	8.0	-4.00	2.40
740+79	683.726	8.0	-5.50	2.40
741+00	683.790	8.0	-5.00	2.40
741+50	683.950	8.0	-4.00	2.40
742+00	684.110	8.0	-3.50	2.40
742+50	684.272	8.0	-3.50	2.40
743+00	684.434	8.0	-4.00	2.40
743+50	684.679	8.0	-4.00	2.40
744+00	684.964	8.0	-4.00	2.40
744+50	685.290	8.0	-4.00	2.40
745+00	685.658	8.0	-4.00	2.40
745+50	686.067	8.0	-4.00	2.40
746+00	686.517	8.0	-4.00	2.40
746+50	687.009	8.0	-4.00	2.40
747+00	687.542	8.0	-4.00	2.40
747+50	688.116	8.0	-4.00	2.40
748+00	688.731	8.0	-4.00	2.40
748+50	689.387	8.0	-4.00	2.40
749+00	690.085	8.0	-4.00	2.40
749+50	690.803	8.0	-4.00	2.40
750+00	691.521	8.0	-4.00	2.40

STA	A GUTTER ELEV	B SHLDR WIDTH	C SHLDR SLOPE	D LN SLOPE
750+50	692.204	8.0	-4.00	2.40
750+70	692.458	8.0	-4.00	2.40
751+00	692.815	8.0	-4.00	2.40
751+50	693.355	8.0	-4.00	2.40
862+50	NA	8.0	-4.00	-1.50
863+00	680.864	8.0	-6.00	-1.50
863+50	681.120	8.0	-3.00	-1.50
864+00	680.917	8.0	-6.00	-1.50
864+50	681.134	8.0	-4.00	-1.50
865+00	681.316	8.0	-2.00	-1.97
865+50	681.132	8.0	-4.00	-3.00
866+00	680.968	8.0	-6.00	-4.03
866+50	681.093	8.0	-4.90	-4.90
867+00	681.255	8.0	-4.90	-4.90
867+50	681.437	8.0	-4.90	-4.90
868+00	681.640	8.0	-4.90	-4.90
868+50	681.865	8.0	-4.90	-4.90
869+00	682.109	8.0	-4.90	-4.90
869+50	682.375	8.0	-4.90	-4.90
870+00	682.624	8.0	-4.90	-4.90
870+50	682.817	8.0	-4.90	-4.90
871+00	682.955	8.0	-4.90	-4.90
871+50	683.111	8.0	-4.00	-4.90
872+00	682.978	8.0	-6.00	-4.90
872+50	683.111	8.0	-4.00	-4.90
873+00	682.878	8.0	-6.00	-4.82
873+50	683.024	8.0	-4.00	-3.79
873+98	682.795	8.0	-6.00	-2.76
874+33	682.923	8.0	-4.00	-1.73
874+48	682.834	8.0	-4.00	-1.73
875+00	NA	8.0	-4.00	-1.50

STA	A GUTTER ELEV	B SHLDR WIDTH	C SHLDR SLOPE	D LN SLOPE
967+50	704.098	4.0	-4.00	-2.00
968+00	703.929	4.0	-4.00	-2.00
968+50	703.802	4.4	-4.00	-2.00
969+00	703.501	7.7	-4.00	-2.00
969+50	703.274	8.0	-4.00	-1.33
970+00	703.100	8.0	-5.00	-0.05
970+50	702.919	8.0	-6.00	1.23
971+00	NA	8.0	-5.00	2.51
971+50	NA	8.0	-4.00	3.80

STA	A GUTTER ELEV	B SHLDR WIDTH	C SHLDR SLOPE	D LN SLOPE
1030+00	NA	8.0	-4.00	-2.00
1030+50	NA	8.0	-4.00	-2.00
1031+00	687.710	8.0	-6.00	-2.00
1031+50	687.899	8.0	-4.00	-2.00
1032+00	688.088	8.0	-2.00	-2.00
1032+50	687.958	8.0	-4.00	-2.00
1033+00	687.827	8.0	-6.00	-2.00
1033+50	688.016	8.0	-4.00	-2.00
1034+00	688.205	8.0	-2.00	-2.00
1034+50	688.075	8.0	-4.00	-2.00
1035+00	687.944	8.0	-6.00	-2.00
1035+50	688.133	8.0	-4.00	-2.00
1036+00	688.322	8.0	-2.00	-2.00
1036+50NA		8.0	-4.00	-2.00

FILE NAME =	USER NAME = grantpm	DESIGNED =	REVISED =
ct\pw_work\WIDOT\GRANTPM\dms31213\08688sp1.dgn		DRAWN =	REVISED =
PLOT SCALE = 50.0000 / IN.		CHECKED =	REVISED =
PLOT DATE = Tue Mar 30 09:22:02 2010		DATE =	REVISED =

**STATE OF ILLINOIS  
DEPARTMENT OF TRANSPORTATION**

## GUTTER WARPING DETAIL

SCALE: SHEET NO. 1 OF 2 SHEETS STA. TO STA.

F.A.P. RTE.	SECTION	COUNTY	TOTAL SHEETS	SHEET NO.
742	37R-4	OGLE	867	445
FED. ROAD DIST. NO.			ILLINOIS FED. AID PROJECT	
			CONTRACT NO. 64E17	

# GUTTER OUTLET, SPECIAL

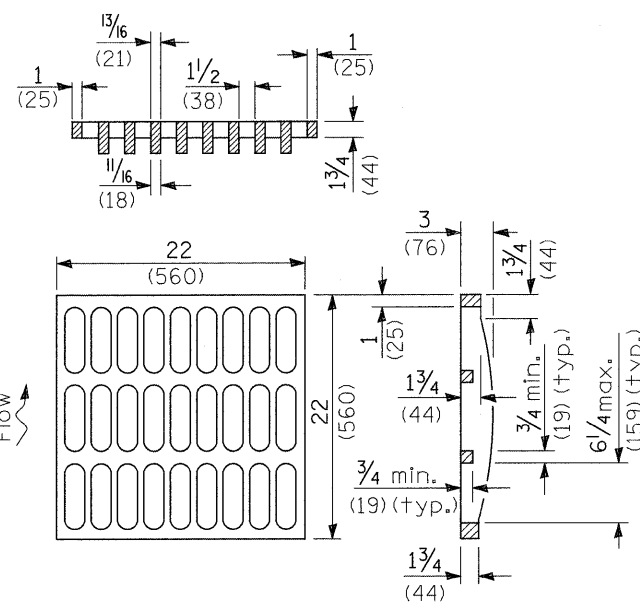
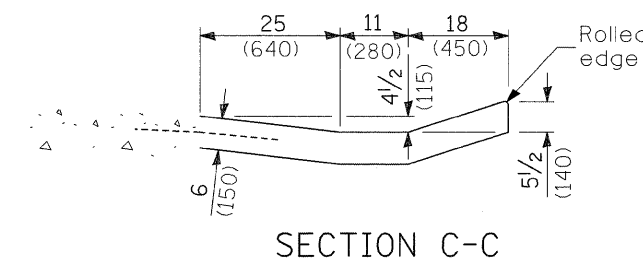
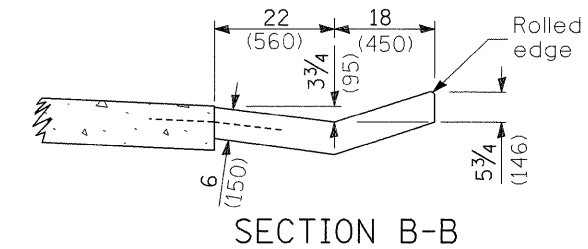
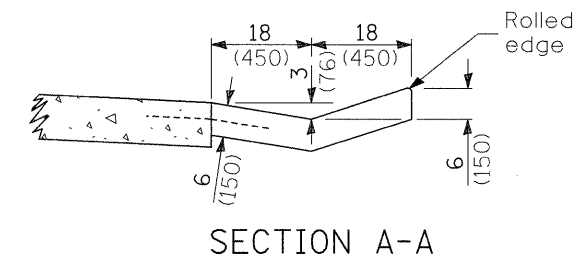
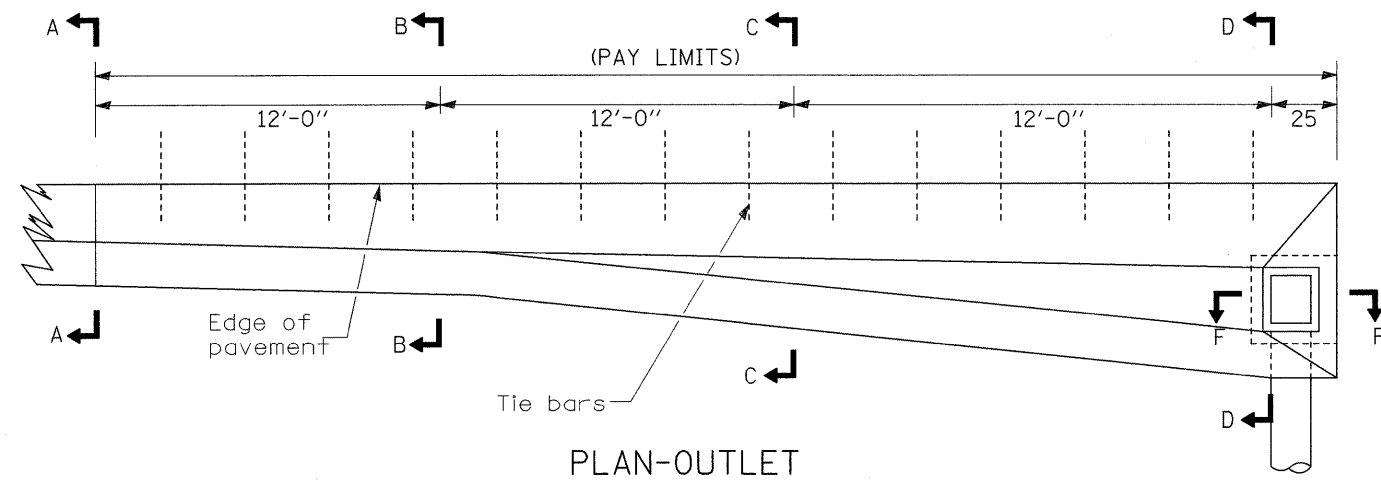

GRATE TYPE A

## QUANTITIES

Material	Quantity
Class SI Concrete - cu. yd.	3.3
Cast Iron Grate - Ea.	1

## GENERAL NOTES

The Gutter Outlet (Special) shall be paid for at the contract unit price per "EACH", GUTTER OUTLET (SPECIAL), which price shall include the cast iron grate, tie bars, Class SI Concrete, and all excavation and backfilling.

The gutter outlet shall be tied to the pavement in accordance with details for longitudinal construction joint shown on Standard 420001.

Tie bars shall be No. 6 (No. 19) at 24 (600) centers unless otherwise shown.

If the average grade of pavement for the distance A-D exceeds 2%, this distance shall be increased 6' (1.8 m) for each 1% increase in grade.

All dimensions are in inches (millimeters) unless otherwise shown.

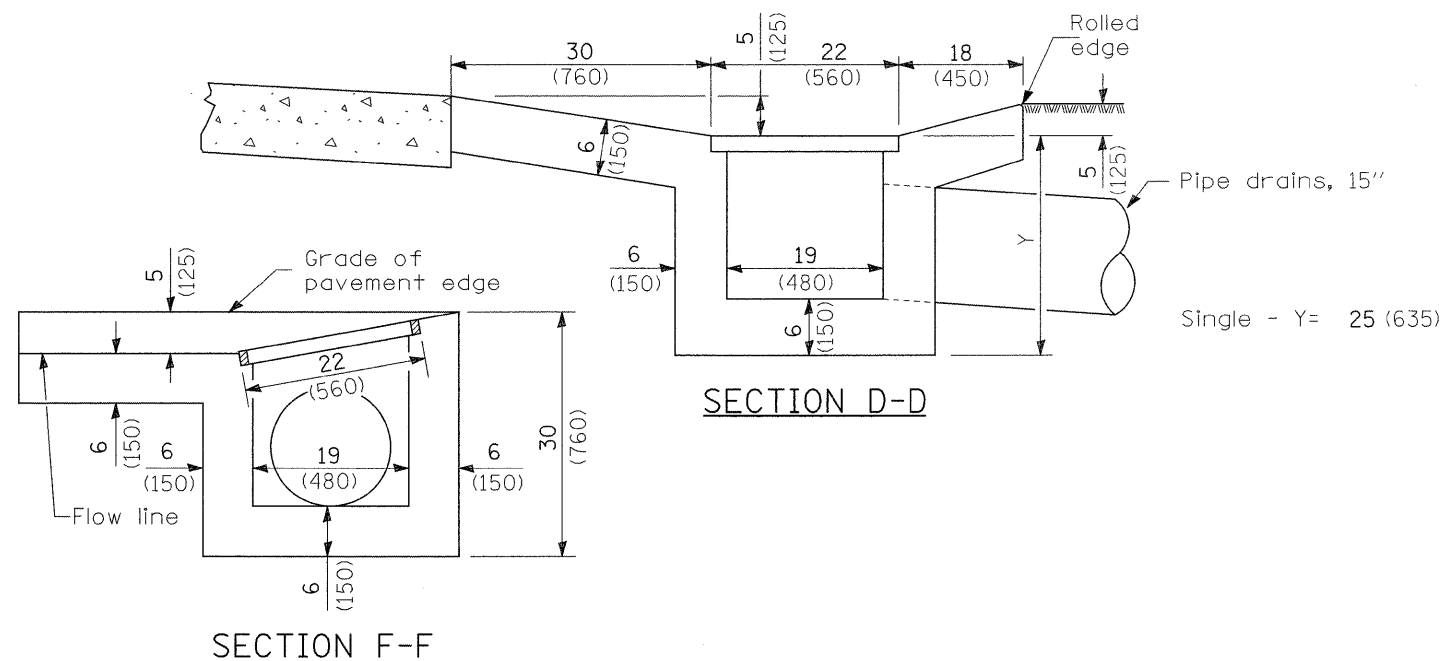

# CURB TRANSITION M-4.24 TO M-6.24

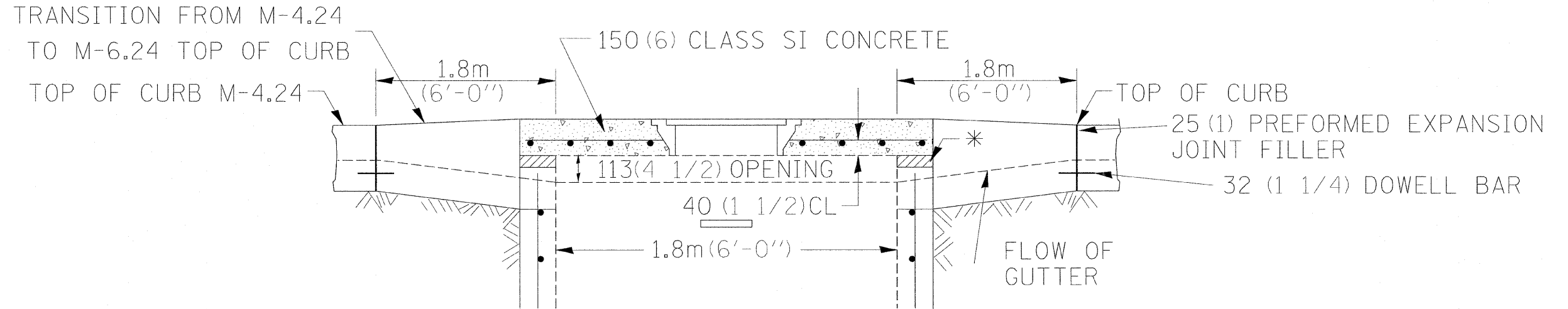

FRONT VIEW

## NOTES

ALL DIMENSIONS ARE IN MILLIMETERS (INCHES) UNLESS OTHERWISE NOTED.

THE CURB AND GUTTER ADJACENT TO THE INLET AND 6' ON EITHER SIDE OF THE INLET SHALL BE CONSTRUCTED AS SHOWN WITH NO ADDITIONAL COMPENSATION FOR THE TRANSITION.

FILE NAME =	USER NAME = cushmanbw	DESIGNED -	REVISED -	<b>STATE OF ILLINOIS DEPARTMENT OF TRANSPORTATION</b>	<b>CURB TRANSITION M-4.24 TO M-6.24</b>	F.A.P. RTE.	SECTION	COUNTY	TOTAL SHEETS	SHEET NO.
at:\pw\work\PWIDOT\CUSHMANBW\dms31213\d06600apl.dgn		DRAWN -	REVISED -			742	37R-4	OGLE	867	447
PLOT SCALE = 50.0000' / IN.		CHECKED -	REVISED -			CONTRACT NO. 64E17				
PLOT DATE = Wed Jun 02 09:15:34 2010		DATE -	REVISED -			ILLINOIS FED. AID PROJECT				
						SCALE:	SHEET NO.	OF	SHEETS	STA. TO STA.

# ARTICULATED BLOCK – CONNECTION DETAIL

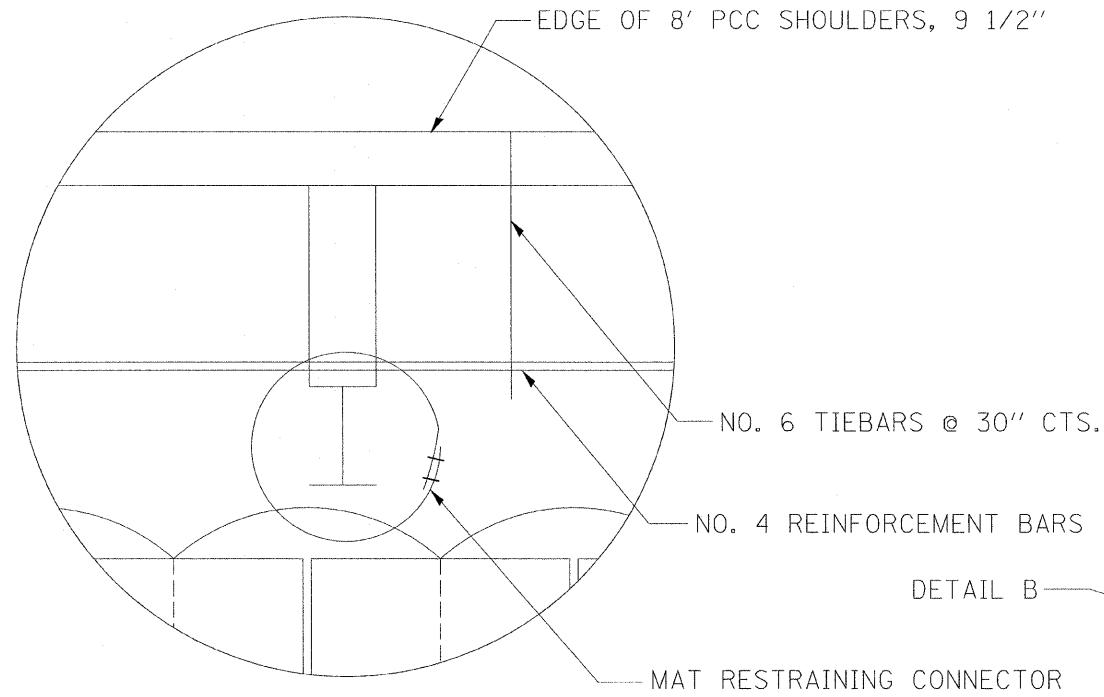

DETAIL A

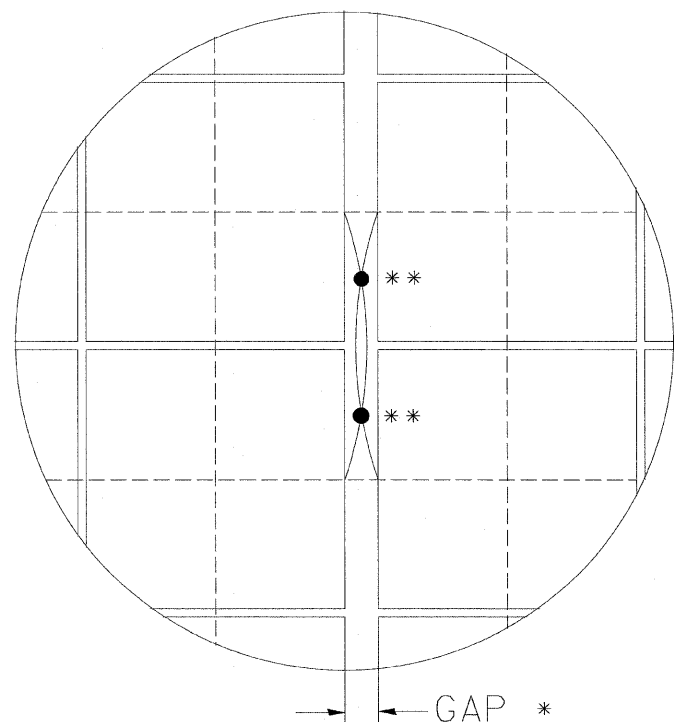

DETAIL B

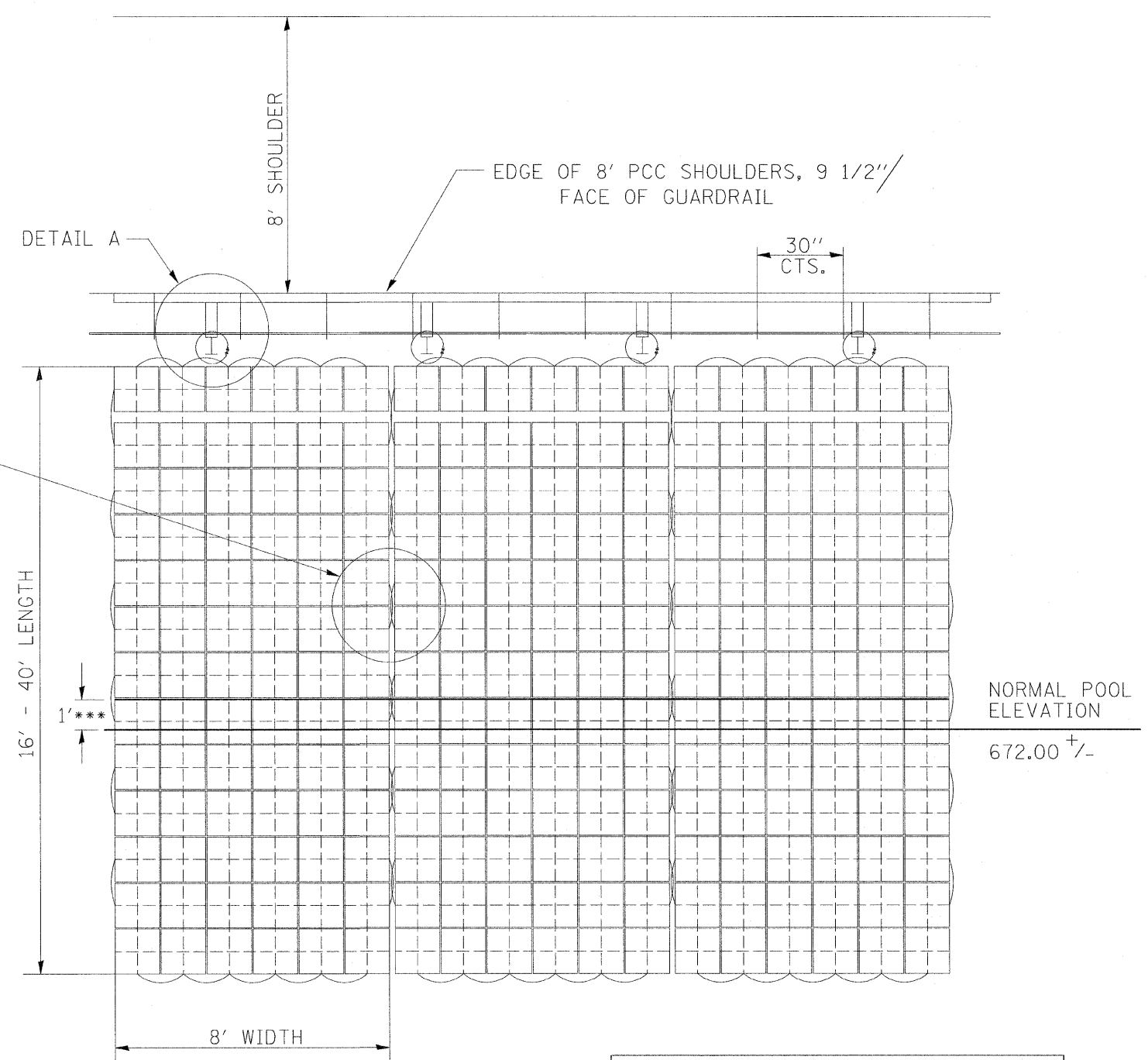

BILL OF MATERIAL	
MAT RESTRAINING CONNECTOR	625 EACH
**** REINFORCEMENT BARS (LBS.)	2833

- \* FOR GAPS > 2" CLASS SI CONCRETE WILL BE REQUIRED
- \*\* TIES TO MATS REQUIRED ABOVE THE NORMAL POOL ELEVATION
- \*\*\* IF THE MAT HAS THE CONSISTENT VERTICAL SEAMS, THEN PLACE THE CLASS SI CONCRETE SEAM HORIZONTALLY AT THE 1' ABOVE THE NORMAL POOL WATER ELEVATION

MINIMUM BAR LAP (NO.4) = 1'-8"  
 \*\*\*\* NO.4 BARS, 40' LENGTHS= (QTY. of 106)

FILE NAME =	USER NAME = cushmanbw	DESIGNED -	REVISED -	<b>STATE OF ILLINOIS DEPARTMENT OF TRANSPORTATION</b>	<b>ARTICULATED BLOCK – CONNECTION DETAIL</b>	F.A.P. RTE.	SECTION	COUNTY	TOTAL SHEETS	SHEET NO.	
est\paw_work\VP\DOT\CUSHMANBW\dms31213\0608sepL.dgn	PLOT SCALE = 50.0000' / IN.	DRAWN -	REVISED -			742	37R-4	OGLE	867	448	
	PLOT DATE = Wed Jun 02 09:15:49 2010	CHECKED -	REVISED -			CONTRACT NO. 64E17					
		DATE -	REVISED -			ILLINOIS FED. AID PROJECT					



# ARTICULATED BLOCK – CULVERT DETAIL

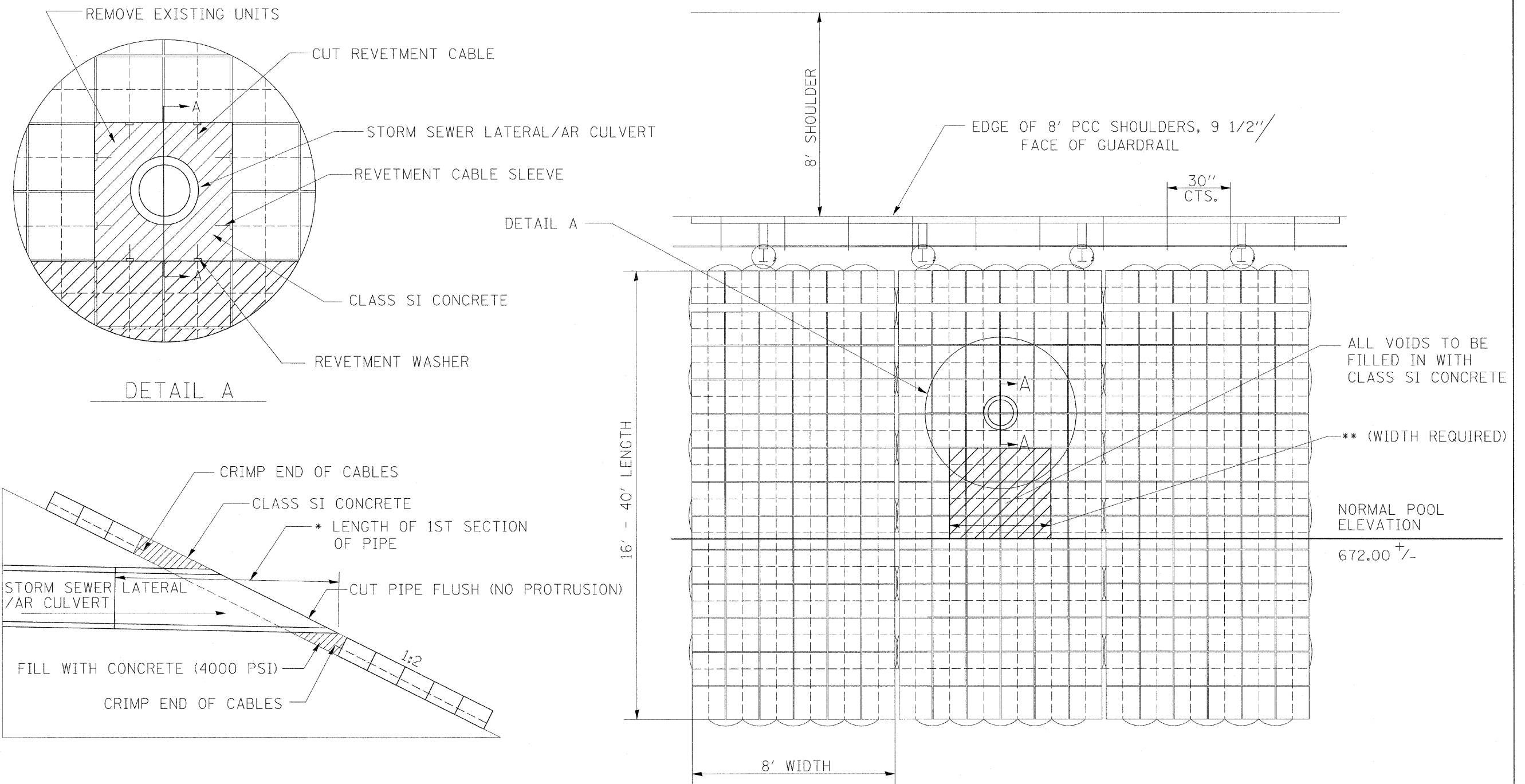

## SECTION A-A

STORM SEWER PASSING THROUGH MATS

## AR CULVERTS

RT. STA 705+09 48" RCP --- \*\* WIDTH REQUIRED = 12'-0"  
 RT. STA 995+90 30" RCP --- \*\* WIDTH REQUIRED = 7'-0"

\* LENGTH OF 1ST SECTION REQUIRED FOR AR CULVERTS = 12'-0"

## STORM SEWER LATERALS

\*\* WIDTH REQUIRED = 3'-0"  
 (SEE DRAINAGE SCHEDULE FOR LOCATIONS)

FILE NAME =	USER NAME = cushmanbw	DESIGNED -	REVISED -	<b>STATE OF ILLINOIS DEPARTMENT OF TRANSPORTATION</b>	<b>ARTICULATED BLOCK – CULVERT DETAIL</b>				F.A.P. RTE.	SECTION	COUNTY	TOTAL SHEETS	SHEET NO.
01\pwwork\VPWIDOT\CUSHMANBW\dms31213\d0608ap1.dgn		DRAWN -	REVISED -		742	37R-4	OGLE	867	449				
PLOT SCALE = 50.0000' / IN.		CHECKED -	REVISED -		SCALE:				CONTRACT NO. 64E17				
PLOT DATE = Wed Jun 02 09:16:00 2010		DATE -	REVISED -		SHEET NO. OF SHEETS STA. TO STA.				ILLINOIS FED. AID PROJECT				

# ARTICULATED BLOCK – FLANK DETAIL

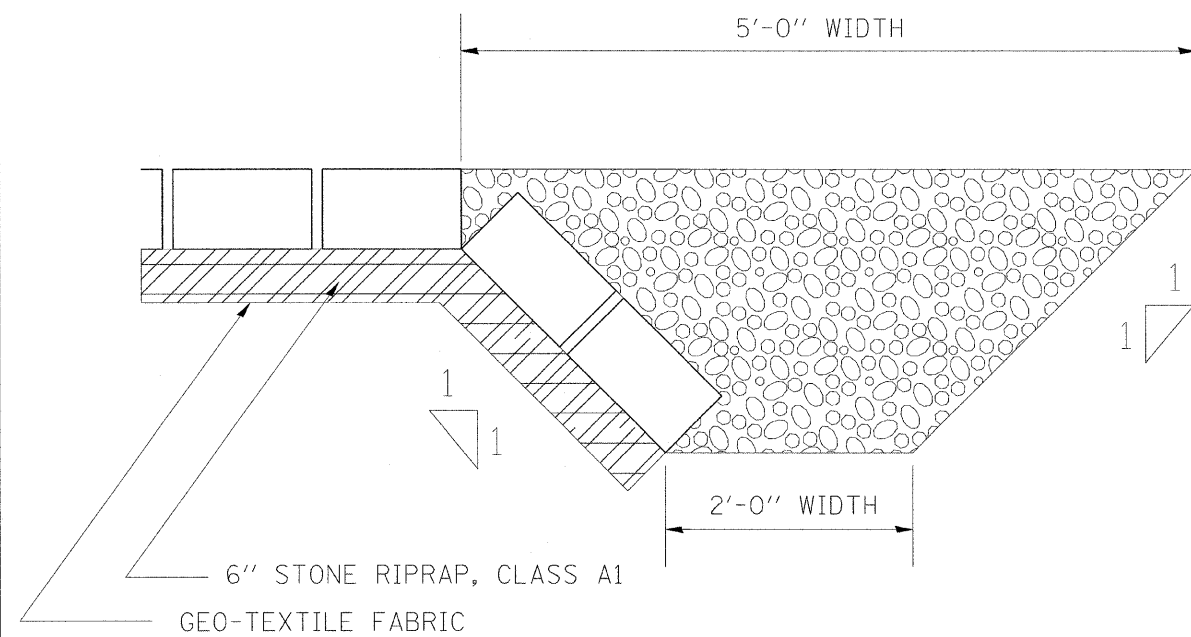

SECTION A-A

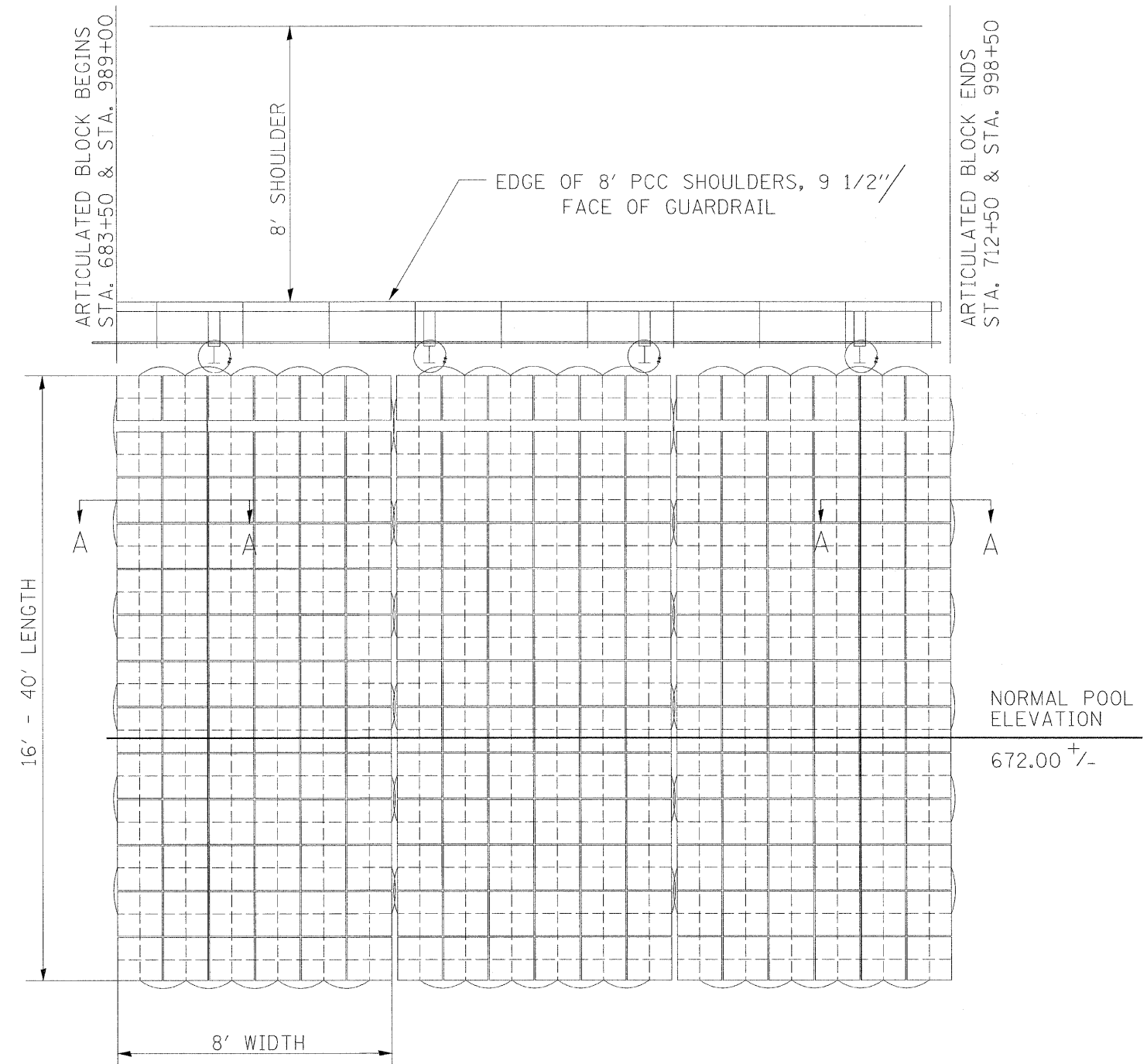

FILE NAME =	USER NAME = cushmanbw	DESIGNED -	REVISED -
ct:\pwwork\pwidot\cushmanbw\dra31213\dr6608sp1.dgn		DRAWN -	REVISED -
	PLOT SCALE = 50.0000' / IN.	CHECKED -	REVISED -
	PLOT DATE = Wed Jun 02 09:16:12 2010	DATE -	REVISED -

STATE OF ILLINOIS  
DEPARTMENT OF TRANSPORTATION

ARTICULATED BLOCK – CONNECTION DETAIL

SCALE: SHEET NO. OF SHEETS STA. TO STA.

F.A.P. RTE.	SECTION	COUNTY	TOTAL SHEETS	SHEET NO.
742	37R-4	OGLE	867	450
CONTRACT NO. 64E17				
ILLINOIS FED. AID PROJECT				

# INLETS, SPECIAL

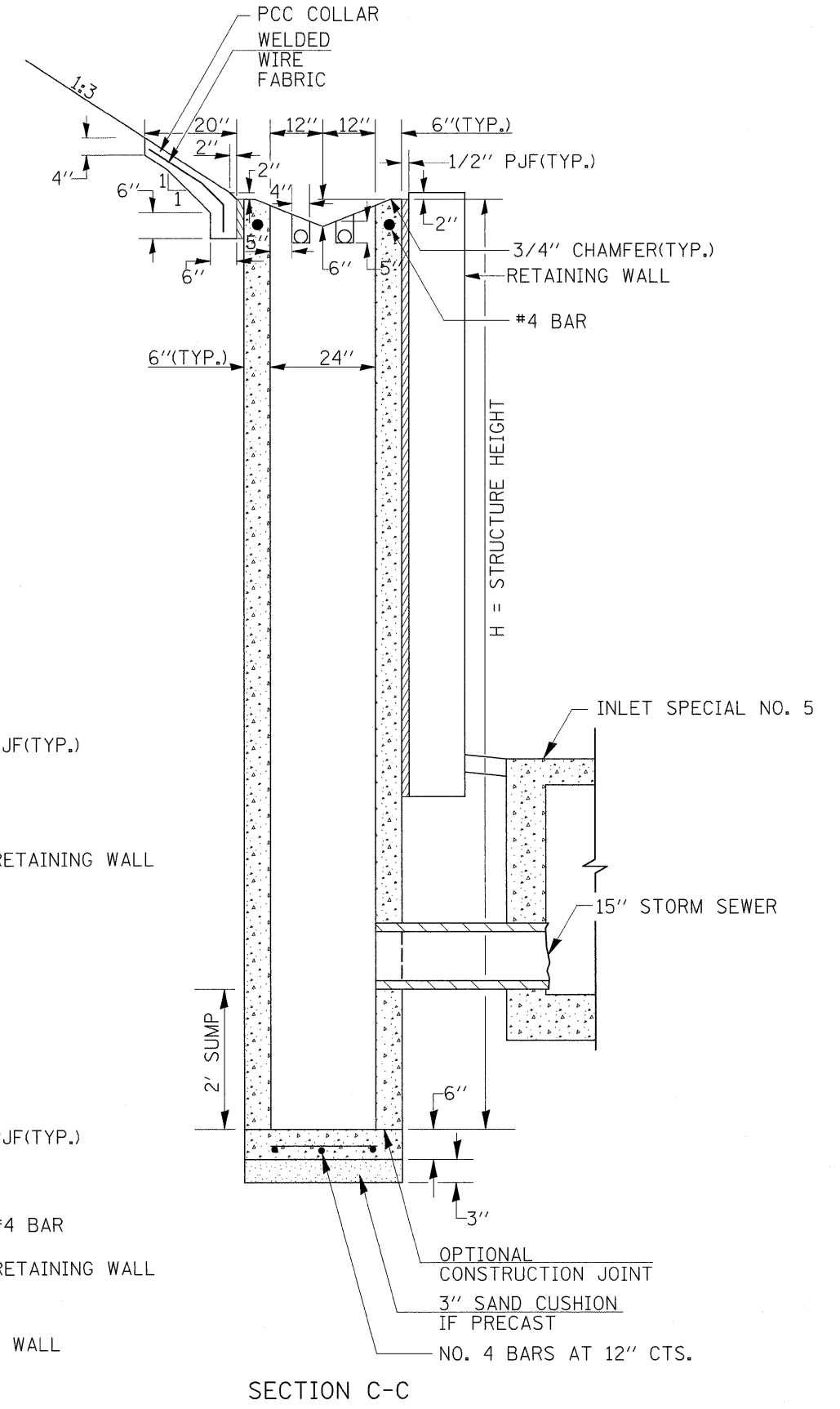
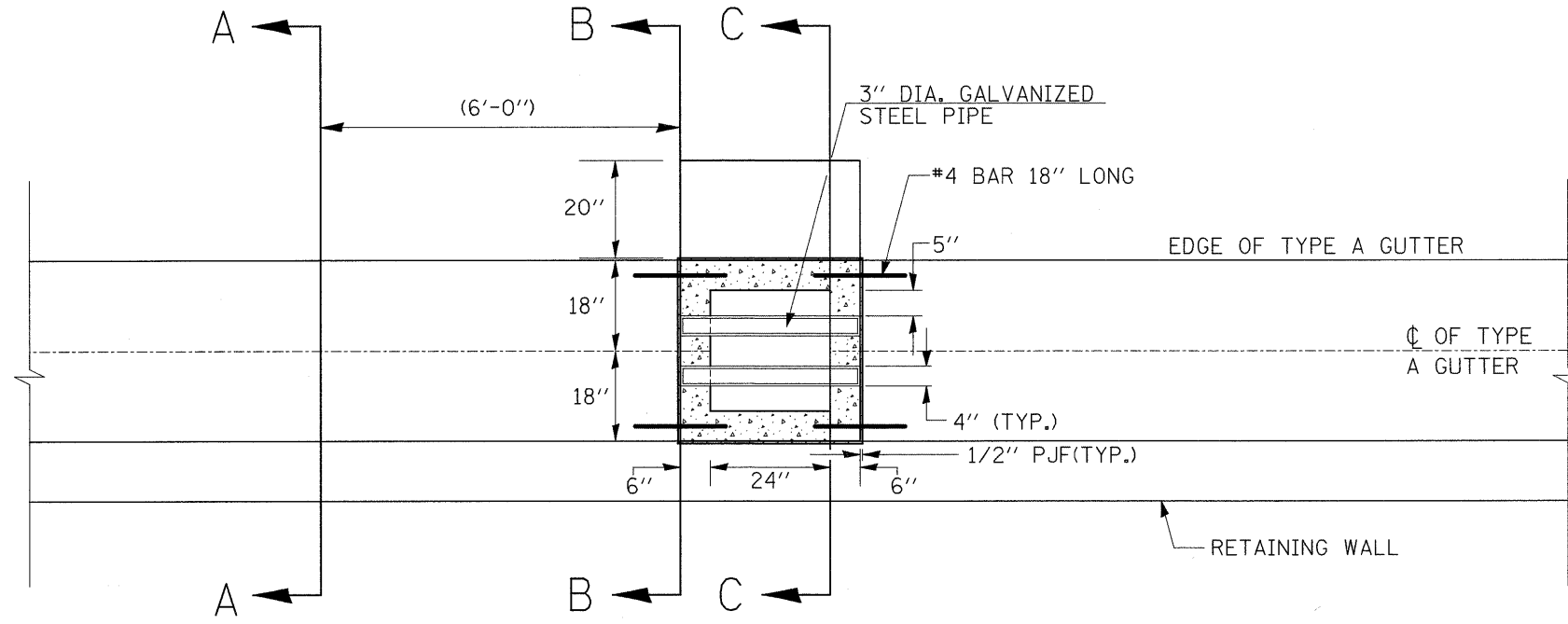

**NOTES:**

- 1) EXCEPT AS NOTED HEREON INLETS, SPECIAL SHALL BE CONSTRUCTED IN ACCORDANCE WITH SECTION 602 OF THE STANDARD SPECIFICATIONS.
- 2) THE CONTRACT UNIT PRICE "EACH" FOR INLETS, SPECIAL SHALL INCLUDE THE COST OF CONSTRUCTING THE INLET BOX, FURNISHING AND INSTALLING THE GALVANIZED STEEL PIPE, THE PRECAST FLOOR SLAB, PCC COLLAR, WELDED WIRE FABRIC, SAND CUSHION (WHEN USED) AND REINFORCEMENT BARS.
- 3) CLASS SI CONCRETE OR PRECAST CONCRETE SHALL BE USED THROUGHOUT. PRECAST CONCRETE SHALL BE IN ACCORDANCE WITH SECTION 504.01 THRU 504.05 OF THE STANDARD SPECIFICATIONS EXCEPT THAT CONCRETE STRENGTH SHALL BE 27.5 MPa (4,000 PSI) AFTER 28 DAYS.
- 4) REINFORCEMENT BARS SHALL CONFORM TO A.S.T.M A-53 (TYPE E OR S) GRADE B, SCHEDULE 40, AND SHALL BE GALVANIZED CONFORMING TO A.S.T.M. A-120.
- 5) THE SIDE WALLS MAY BE BUILT AS PRECAST SEGMENTED SECTIONS.
- 6) ALL VOIDS AROUND PIPE ENTRANCE, BOTH INSIDE AND OUTSIDE, SHALL BE SEALED WITH MORTAR.

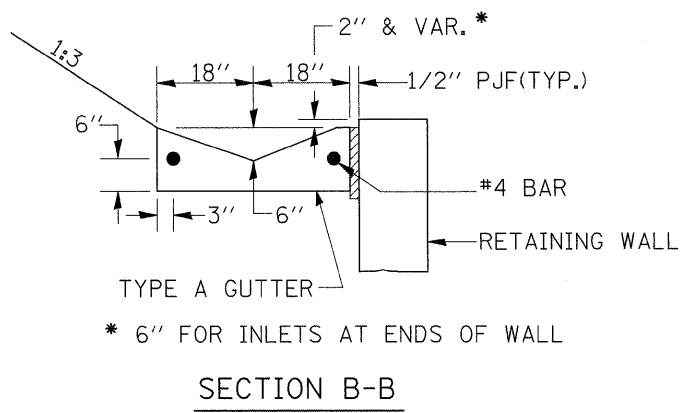
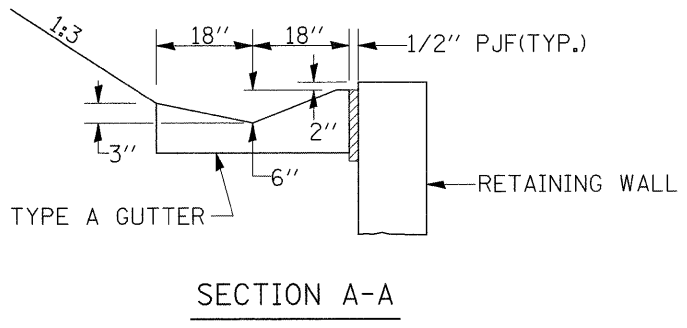

FILE NAME =	USER NAME = grantpm	DESIGNED -	REVISED -	<b>STATE OF ILLINOIS DEPARTMENT OF TRANSPORTATION</b>	<b>INLETS, SPECIAL</b>	F.A.P. RTE.	SECTION	COUNTY	TOTAL SHEETS	SHEET NO.	
os\pwork\PMIDOT\GRANTPM\dms31213\d06628spl.dgn	PLOT SCALE = 50.0000' / IN.	DRAWN -	REVISED -			742	37R-4	OGLE	867	451	
PLOT DATE = Tue Mar 30 09:22:06 2010	DATE -	CHECKED -	REVISED -			CONTRACT NO. 64E17					
		DATE -	REVISED -			ILLINOIS FED. AID PROJECT					
					SCALE:	SHEET NO.	OF SHEETS	STA.	TO STA.		

# INLETS, SPECIAL (Wall Offset Locations)

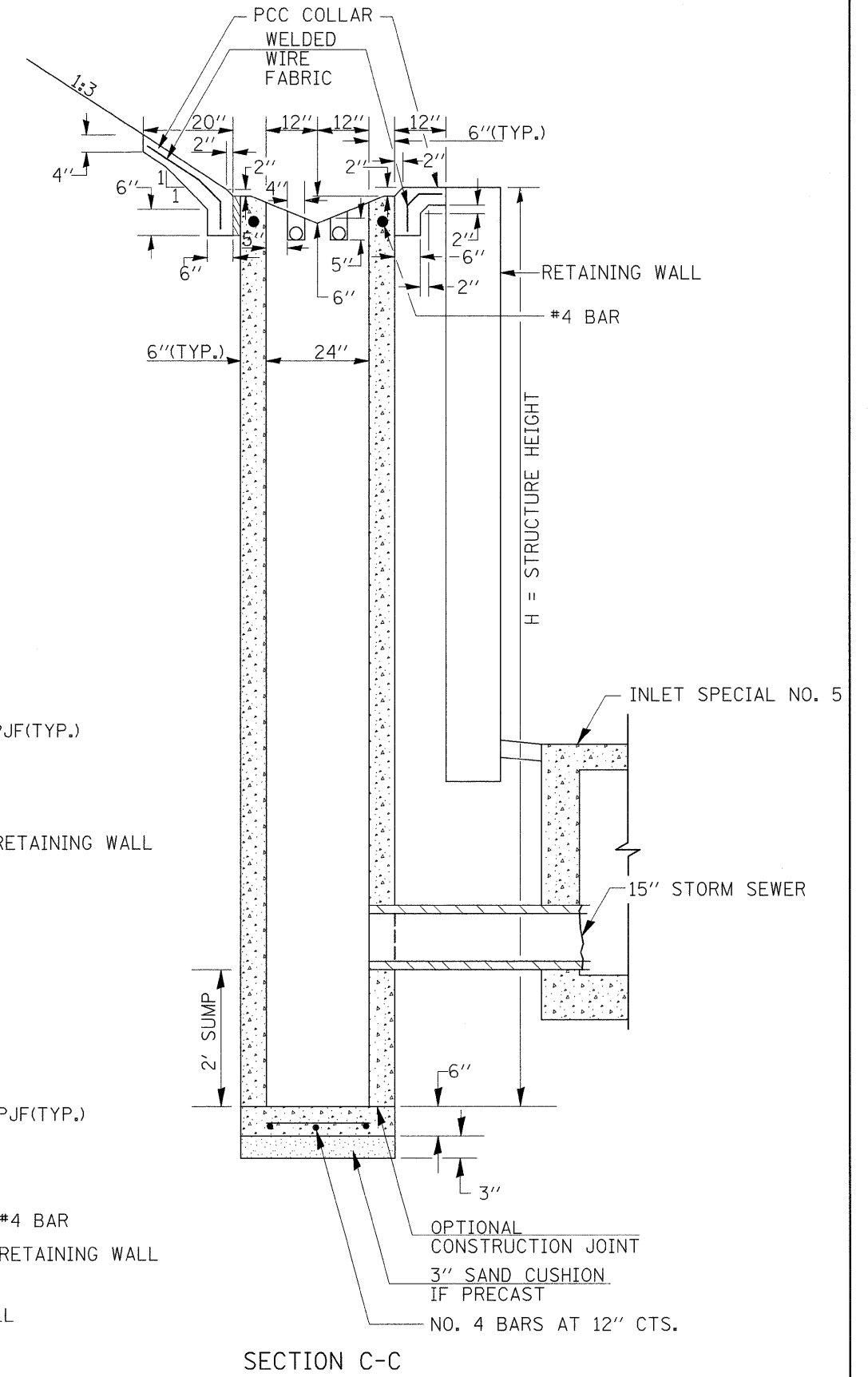
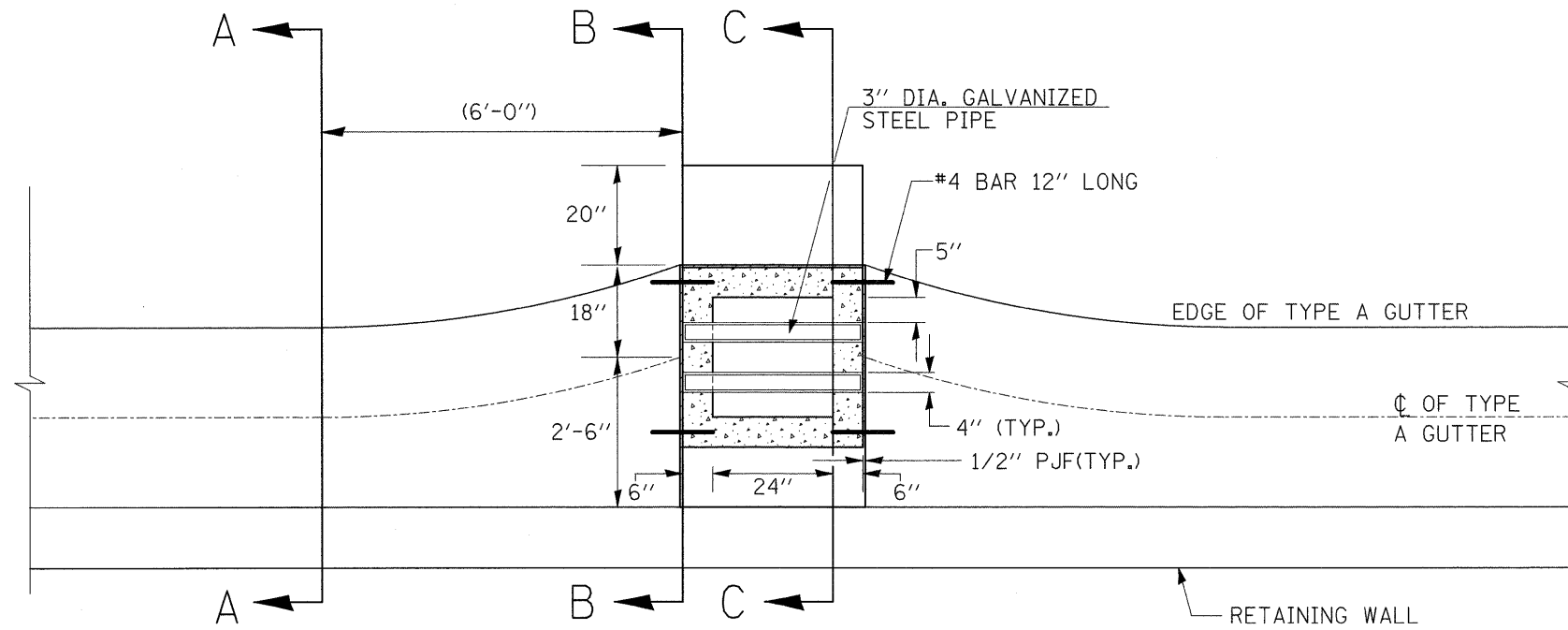

**NOTES:**

- 1) EXCEPT AS NOTED HEREON INLETS, SPECIAL SHALL BE CONSTRUCTED IN ACCORDANCE WITH SECTION 602 OF THE STANDARD SPECIFICATIONS.
- 2) THE CONTRACT UNIT PRICE "EACH" FOR INLETS, SPECIAL SHALL INCLUDE THE COST OF CONSTRUCTING THE INLET BOX, FURNISHING AND INSTALLING THE GALVANIZED STEEL PIPE, THE PRECAST FLOOR SLAB, PCC COLLAR, WELDED WIRE FABRIC, SAND CUSHION (WHEN USED) AND REINFORCEMENT BARS.
- 3) CLASS SI CONCRETE OR PRECAST CONCRETE SHALL BE USED THROUGHOUT. PRECAST CONCRETE SHALL BE IN ACCORDANCE WITH SECTION 504.01 THRU 504.05 OF THE STANDARD SPECIFICATIONS EXCEPT THAT CONCRETE STRENGTH SHALL BE 27.5 MPa (4,000 PSI) AFTER 28 DAYS.
- 4) REINFORCEMENT BARS SHALL CONFORM TO A.S.T.M A-53 (TYPE E OR S) GRADE B, SCHEDULE 40, AND SHALL BE GALVANIZED CONFORMING TO A.S.T.M. A-120.
- 5) THE SIDE WALLS MAY BE BUILT AS PRECAST SEGMENTED SECTIONS.
- 6) ALL VOIDS AROUND PIPE ENTRANCE, BOTH INSIDE AND OUTSIDE, SHALL BE SEALED WITH MORTAR.

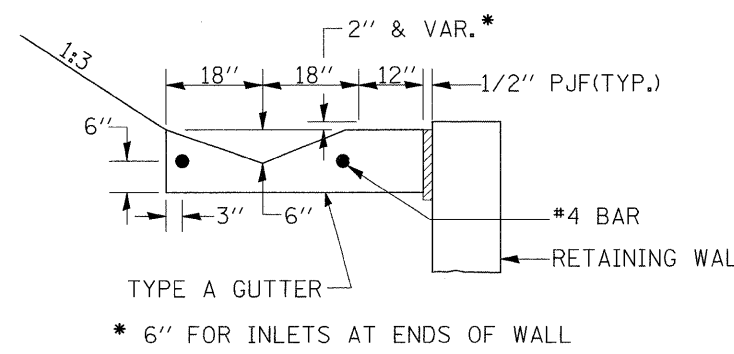
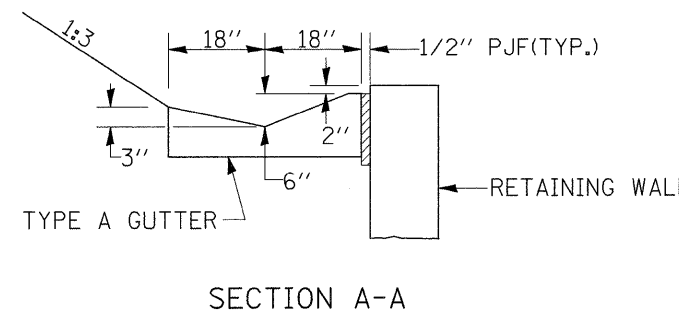

\* 6" FOR INLETS AT ENDS OF WALL

FILE NAME =	USER NAME = grantpm	DESIGNED -	REVISED -	<b>STATE OF ILLINOIS DEPARTMENT OF TRANSPORTATION</b>	<b>INLETS, SPECIAL (Wall Offset Locations)</b>	F.A.P. RTE. 742	SECTION 37R-4	COUNTY OGLE	TOTAL SHEETS 867	SHEET NO. 452
CONTRACT NO. 64E17	SCALE:	SHEET NO. OF SHEETS	STA. TO STA.			ILLINOIS FED. AID PROJECT				
PLOT SCALE = 50.0000' / IN.	CHECKED -	REVISED -								
PLOT DATE = Tue Mar 30 09:22:06 2010	DATE -	REVISED -								

# TEMPORARY SIGNAL DETAIL

NOTE:  
THIS DRAWING IS NOT TO  
SCALE. IT IS ONLY A SKETCH  
OF THE INTERSECTION AND TOPO.  
POLE LOCATIONS ARE ESTIMATED,  
THEY MUST BE FIELD VERIFIED.

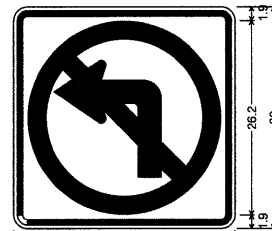
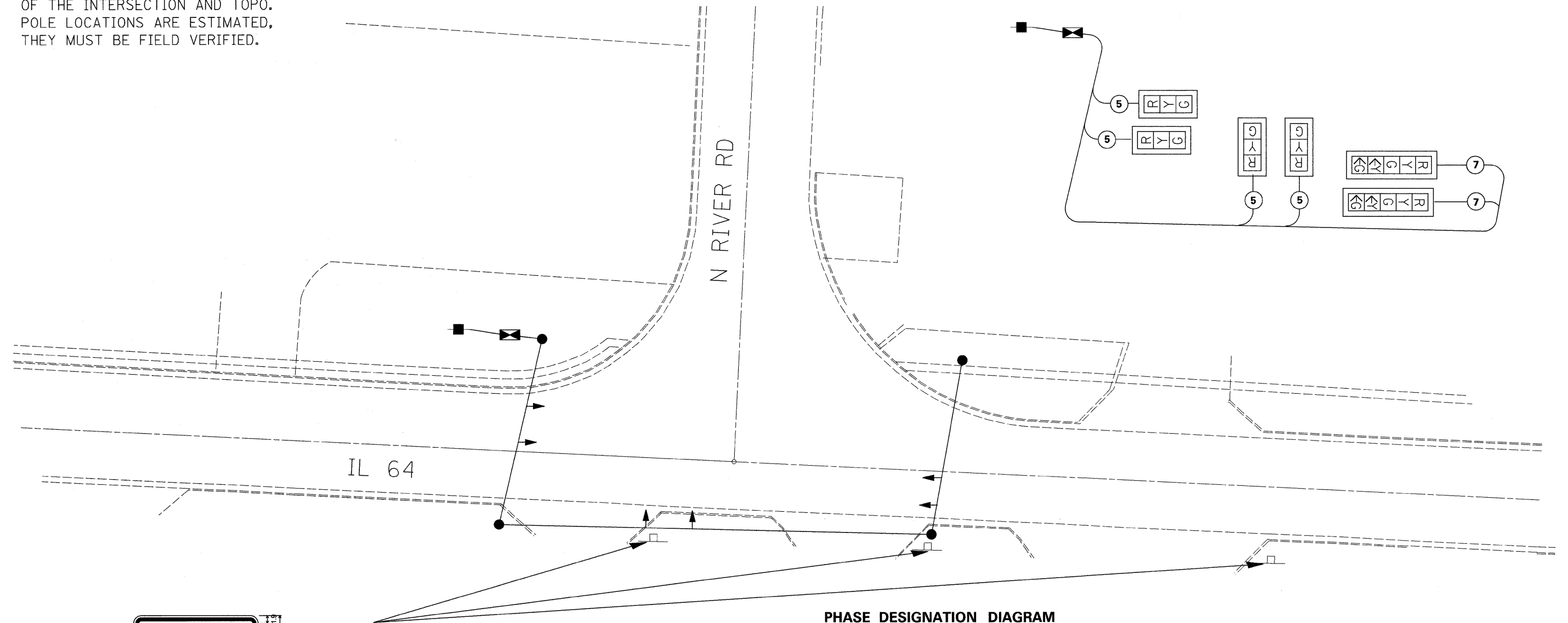

R3-2\_30x30;  
1.9" Radius, 0.8" Border, 0.5" Indent, Black on White;  
Table of letter and object letters.

NO LEFT TURN SIGNS TO BE PLACED ON  
COMMERCIAL ENTRANCES THE CONTRACTOR  
SHALL ADVISE THE PROPERTY OWNERS PRIOR  
TO PLACEMENT OF SIGNS

PHASE DESIGNATION DIAGRAM

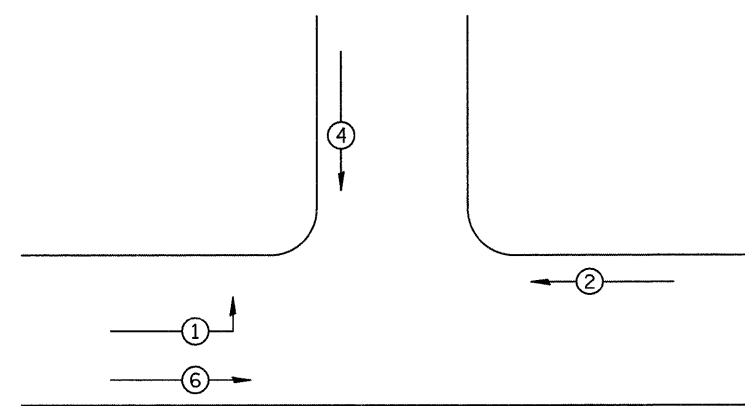

VEHICULAR  
MOVEMENT  
NUMBER REFERS TO  
ASSOCIATED PHASE

REFER TO STANDARD 857001

FILE NAME =	USER NAME = grantpm	DESIGNED -	REVISED -	<b>STATE OF ILLINOIS DEPARTMENT OF TRANSPORTATION</b>	<b>TEMPORARY SIGNAL DETAIL</b>	F.A.P. RTE. 742	SECTION 37R-4	COUNTY OGLE	TOTAL SHEETS 867	SHEET NO. 453	
or\pwork\pwidot\GRANTPM\dms31213\d06628spL.dgn	PLOT SCALE = 50.0000' / IN.	CHECKED -	REVISED -			SCALE:	SHEET NO. OF SHEETS STA. TO STA.	CONTRACT NO. 64E17			
PLOT DATE = Tue Mar 30 09:22:07 2010	DATE -	REVISED -	REVISED -			ILLINOIS FED. AID PROJECT					

# LIGHTING DETAILS

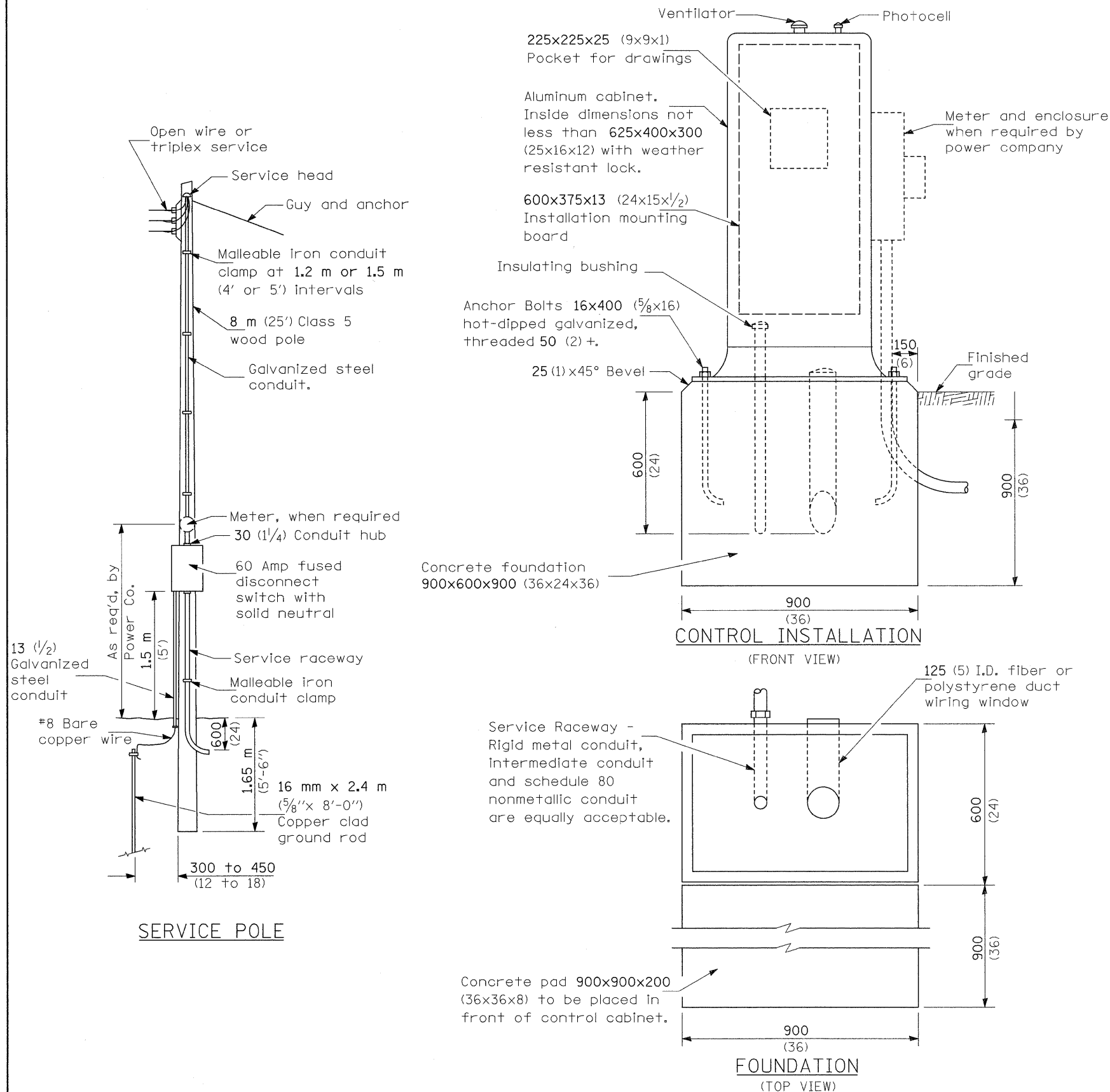

- A Selector switch
- B 2 Pole 100 amp contactor
- C 2 Pole 60 amp service disconnect
- D,E,F 2 Pole 30 amp breakers
- G Photocell w/integral surge arrester

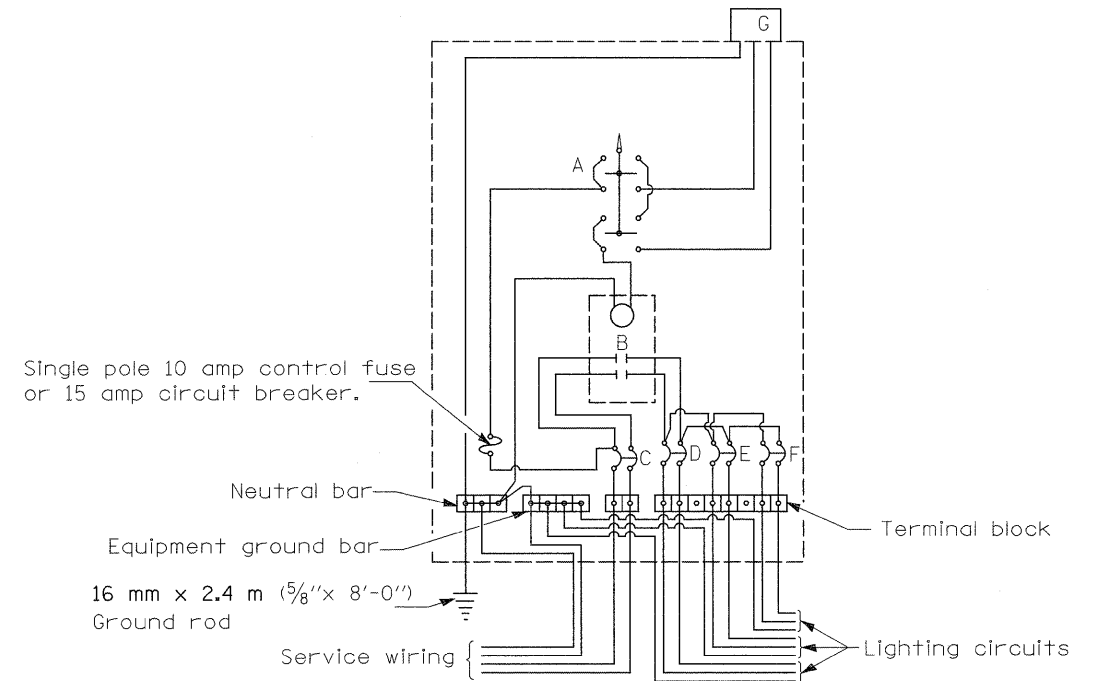

WIRING DIAGRAM

### GENERAL NOTES

Locate service pole and control installation adjacent to R.O.W. line with a minimum distance of 9 m (30') from the edge of pavement. Exact location shall be established by the Engineer.

The underground service entrance wiring shall not exceed 46 m (150'). Total aerial and underground service between the control installation and primary transformer shall not exceed 76 m (250').

Raceways shall terminate 75 (3) above top of concrete foundation.

For 480 V. systems, a 480/120 V. control transformer will be required.

All dimensions are in millimeters unless otherwise shown.

- 240 V. SERVICE
- 480 V. SERVICE

## CONTROL INSTALLATION TYPE CB-RCS-100

FILE NAME =	USER NAME = grantpm	DESIGNED -	REVISED -	<b>STATE OF ILLINOIS DEPARTMENT OF TRANSPORTATION</b>	<b>LIGHTING DETAILS</b>	F.A.P. RTE.	SECTION	COUNTY	TOTAL SHEETS	SHEET NO.
ct:\pw_work\VPWIDOT\GRANTPM\dms31213\d06628spl.dgn		DRAWN -	REVISED -			742	37R-4	OGLE	867	454
PLOT SCALE = 50.0000' / IN.		CHECKED -	REVISED -			CONTRACT NO. 64E17				
PLOT DATE = Tue Mar 30 09:22:08 2010		DATE -	REVISED -			ILLINOIS FED. AID PROJECT				
SCALE:						SHEET NO.	OF	SHEETS	STA.	TO STA.

# LIGHTING DETAILS

"Install and orient arm bracket over pole tenon and firmly hand tighten the two set screws. Use third hole in arm bracket as a guide to drill a 8.3 (2/4) diameter hole through tenon. Install and tighten self-tapping screw. Tighten set screws an additional (1/4 to 3/8) turn with hex key (not provided). Install locknuts on set screws if threaded projection allows."

Pole shall meet AASHTO Standard Specifications for 128.72 km (80 mph) wind loading and 40.82 kg (90 lb.), .37 m<sup>2</sup> (4.0 sq. ft.) E.P.A. luminaire.

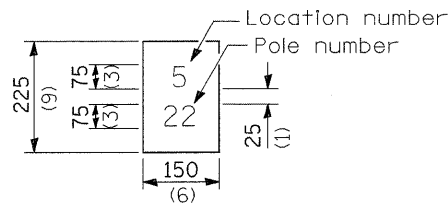

The contractor shall furnish and install a light pole identification of each new light pole, as shown above, incidental to the respective light pole pay item. The numerals shall be 75 (3) series "D", black, screened on silver-white type B pressure sensitive reflective sheeting conforming to the requirements of section T602.01 of the Standard Specifications for Traffic Control Items. The numerals shall conform to the FHWA "Standard Alphabets for Highway Signs".

The light pole identification shall be applied to sign base material as specified in section 1085.05 of the Standard Specifications, approximately 180 (7) above the adjacent pavement grade visible to approaching traffic in accordance with Highway Standard 2319.

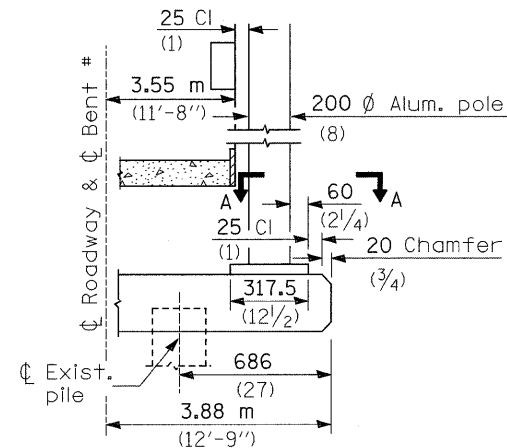

**BENT #**  
(Looking)

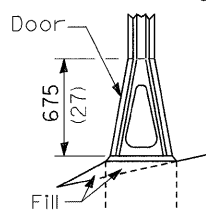

**STAINLESS STEEL FLAIR BASE**

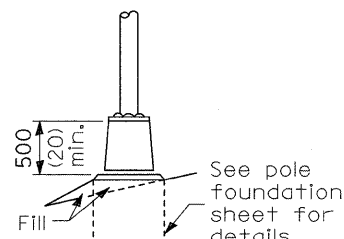

**TRANSFORMER BASE**

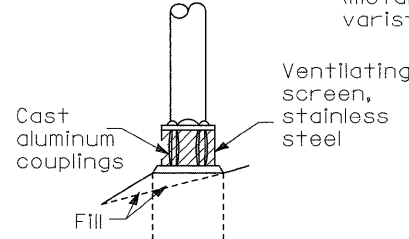

**BREAKAWAY COUPLING**

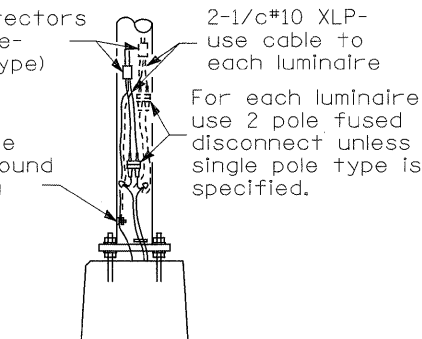

**ANCHOR**

**METAL** OR  **CONCRETE**

Details for underground distribution if required

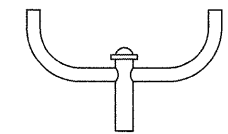

**TWIN TENON**

**TENON MOUNT BRACKET ARM**

NOTE: Single or twin arm assembly shall be tilted 3° above horizontal.

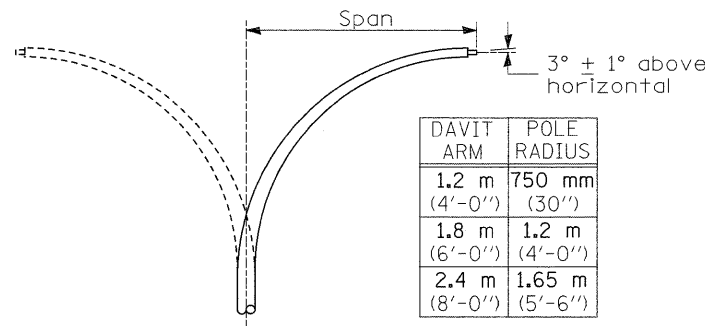

**DAVIT ARM** (and or)

**DAVIT ARM-TWIN**

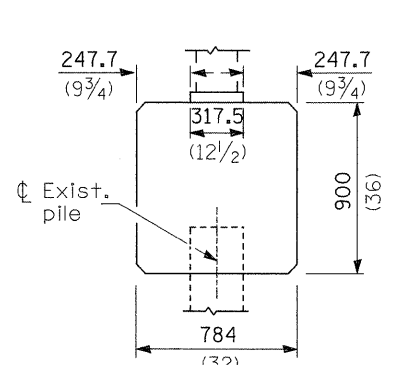

**BRIDGE PIER MOUNT**

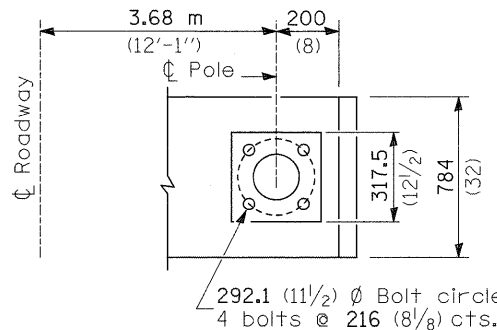

**SECTION A-A**

Surge protectors (metal oxide varistor type)

2-1/c #10 XLP-use cable to each luminaire

For each luminaire use 2 pole fused disconnect unless single pole type is specified.

Pole ground lug

Ventilating screen, stainless steel

Cast aluminum couplings

500 (20) min.

See pole foundation sheet for details

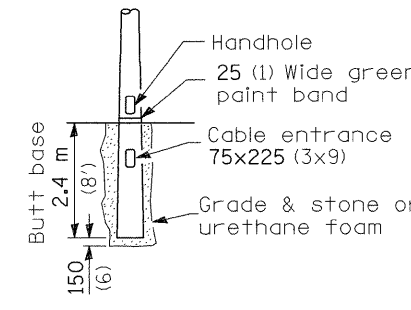

**BUTT BASE**

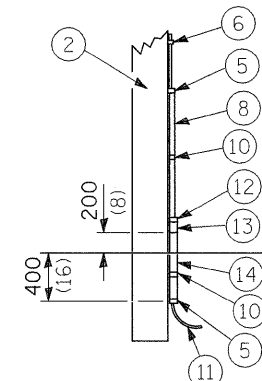

**POLE, WOOD**

POLE LENGTH	DEPTH IN GROUND
19.8 m (65')	3.6 m (12')
18.0 m (60')	3.0 m (10')
16.8 m (55')	2.7 m (9')
16.0 m (50')	2.4 m (8')
13.7 m (45')	2.1 m (7')
12.0 m (40')	2.0 m (6.5')
10.7 m (35')	1.8 m (6')
9.0 m (30')	1.7 m (5.5')

All dimensions are in millimeters (inches) unless otherwise shown.

## POLE STANDARDS

# LIGHTING DETAILS

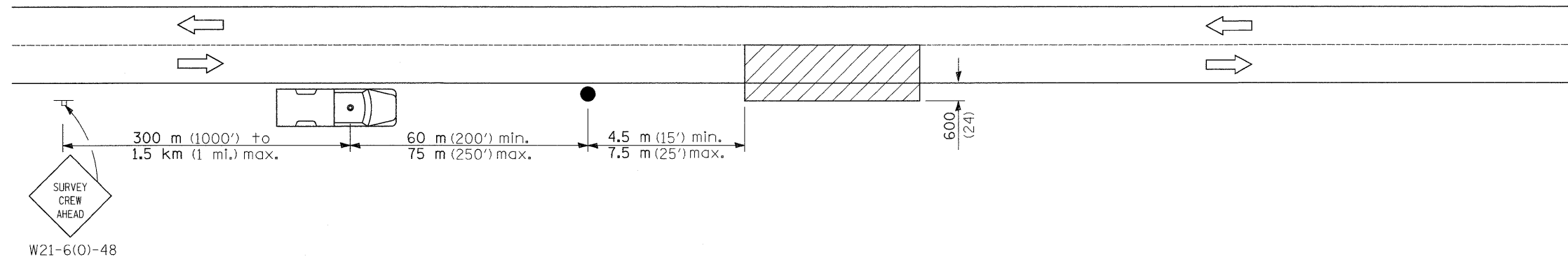

## SYMBOLS

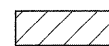

Work area



Sign on portable or permanent support

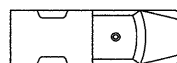

Truck with flashing amber light and dual emergency flashers



Flagger with traffic control sign

TYPICAL APPLICATIONS  
Utility operations

All dimensions are in millimeters (inches) unless otherwise shown.

DETAIL FOR  
NIGHTTIME LIGHTING  
INSPECTION

FILE NAME =	USER NAME = grantpm	DESIGNED -	REVISED -	<b>STATE OF ILLINOIS DEPARTMENT OF TRANSPORTATION</b>	<b>LIGHTING DETAILS</b>	F.A.P. RTE.	SECTION	COUNTY	TOTAL SHEETS	SHEET NO.
cr:\pw_work\PIWIDOT\GRANTPM\dms31213\006628apl.dgn	PLOT SCALE = 50.0000' / IN.	DRAWN -	REVISED -			742	37R-4	OGLE	867	456
PLOT DATE = Tue Mar 30 09:22:10 2010	DATE -	CHECKED -	REVISED -			CONTRACT NO. 64E17				
						ILLINOIS FED. AID PROJECT				
SCALE: SHEET NO. OF SHEETS STA. TO STA.										



# TRAFFIC CONTROL DETAILS

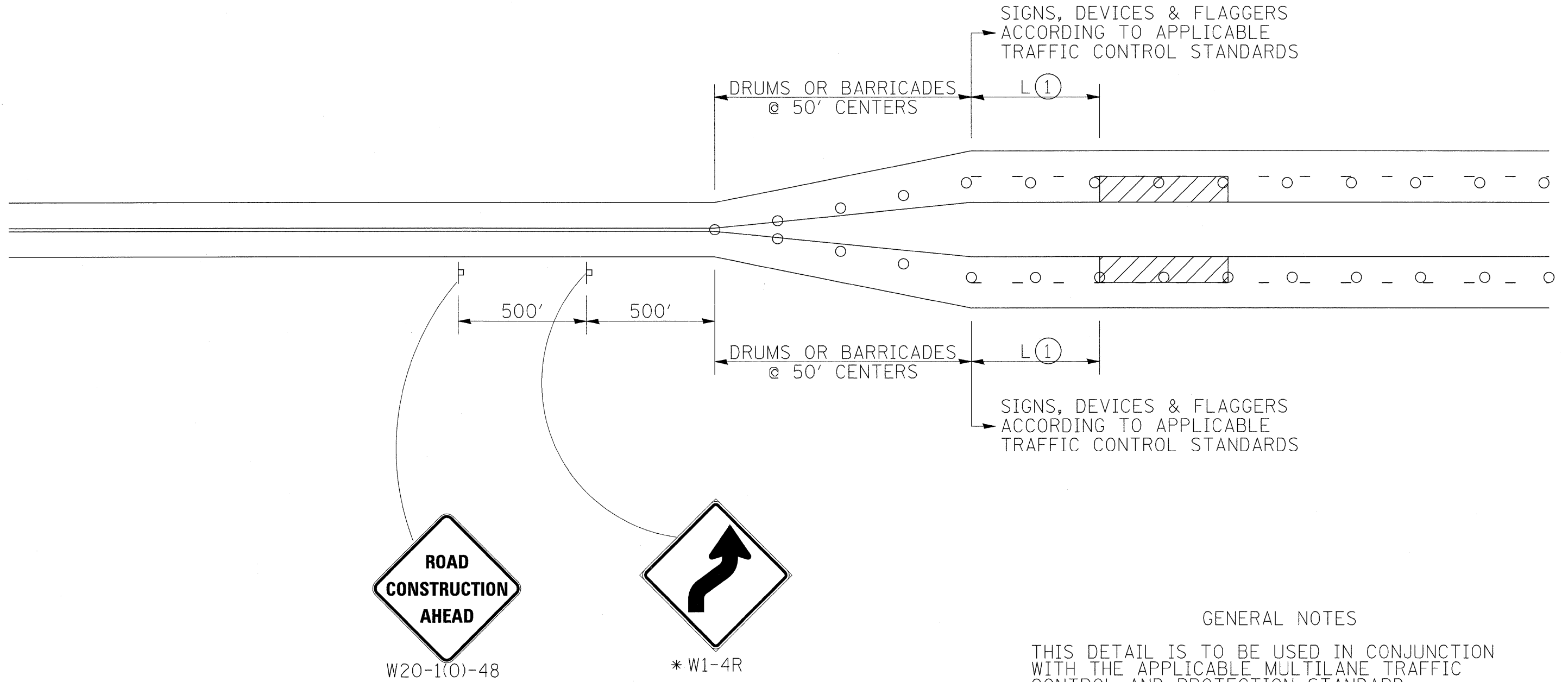

SIGNS, DEVICES & FLAGGERS  
ACCORDING TO APPLICABLE  
TRAFFIC CONTROL STANDARDS

SIGNS, DEVICES & FLAGGERS  
ACCORDING TO APPLICABLE  
TRAFFIC CONTROL STANDARDS

### GENERAL NOTES

THIS DETAIL IS TO BE USED IN CONJUNCTION WITH THE APPLICABLE MULTILANE TRAFFIC CONTROL AND PROTECTION STANDARD.

1. If the work is within 2500 feet of the transition when the speed is > 40 mph, or 1500 for all other speeds, the detail shall be used.

THIS TRAFFIC CONTROL DETAIL SHALL BE INCLUDED IN THE COST OF SPECIFIED TRAFFIC CONTROL STANDARDS OR ITEMS.

○ DRUMS OR BARRICADES  
 WORK AREA

\* DEPENDS ON GEOMETRICS OF THE TRANSITION. MAY SWITCH THE "STAY IN YOUR LANE" AND "WEAVE SIGNS"

FILE NAME =	USER NAME = grantpm	DESIGNED -	REVISED -	<b>STATE OF ILLINOIS DEPARTMENT OF TRANSPORTATION</b>	<b>IL ROUTE 2 TRAFFIC CONTROL DETAILS</b>			F.A.P. RTE.	SECTION	COUNTY	TOTAL SHEETS	SHEET NO.
cs:\pwwork\VPWIDOT\GRANTPM\dms31213\086628spl.dgn	PLOT SCALE = 20.0000' / IN.	DRAWN -	REVISED -					742	37R-4	OGLE	867	457
	PLOT DATE = Tue Mar 30 09:22:10 2010	CHECKED -	REVISED -		SCALE: SHEET NO. OF SHEETS STA. TO STA.			CONTRACT NO. 64E17				
		DATE -	REVISED -		ILLINOIS FED. AID PROJECT							

# TRAFFIC CONTROL DETAILS

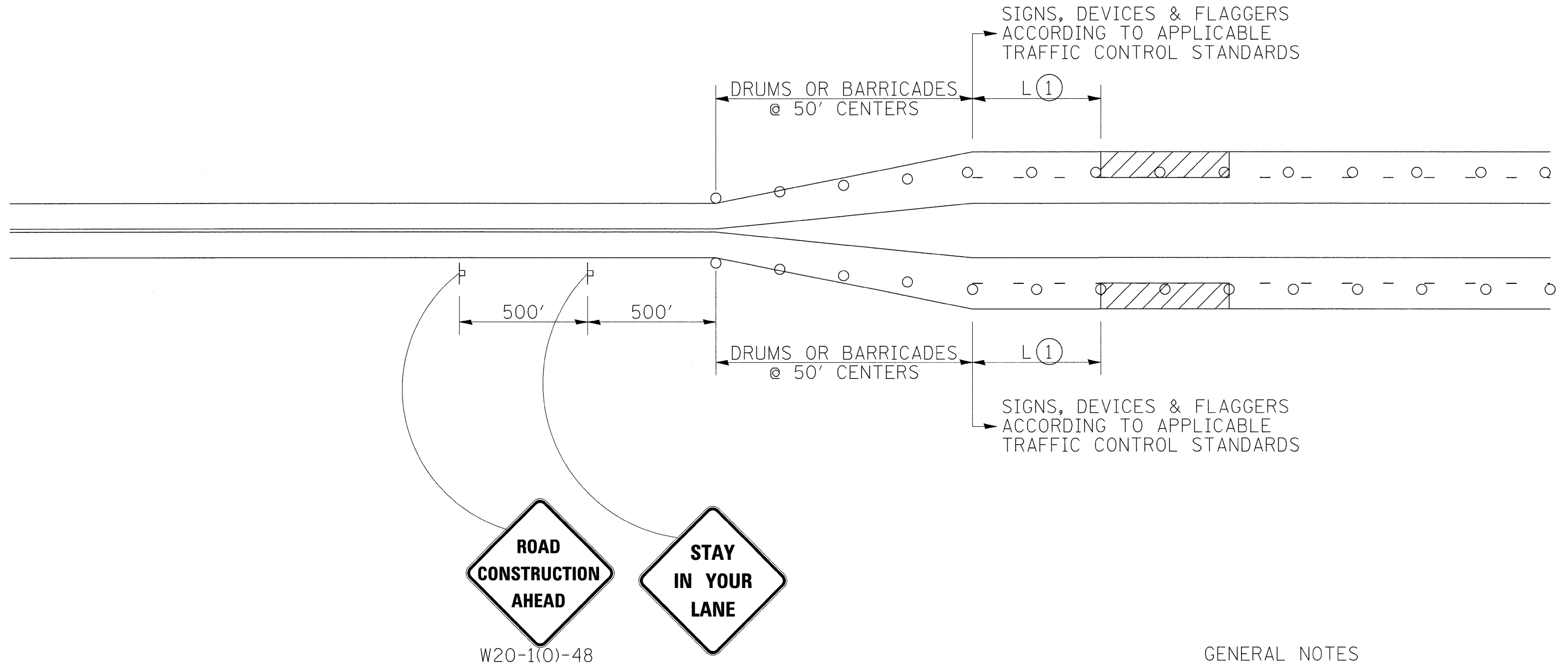

## GENERAL NOTES

THIS DETAIL IS TO BE USED IN CONJUNCTION WITH THE APPLICABLE MULTILANE TRAFFIC CONTROL AND PROTECTION STANDARD.

1. If the work is within 2500 feet of the transition when the speed is > 40 mph, or 1500 for all other speeds, the detail shall be used.

THIS TRAFFIC CONTROL DETAIL SHALL BE INCLUDED IN THE COST OF SPECIFIED TRAFFIC CONTROL STANDARDS OR ITEMS.

○ DRUMS OR BARRICADES

 WORK AREA

NOTE: STANDARDS 701301 AND 701306 SHALL NOT BE USED WITHIN 500 FEET OF THE TRANSITION.

FILE NAME =	USER NAME = grantpm	DESIGNED -	REVISED -	<b>STATE OF ILLINOIS DEPARTMENT OF TRANSPORTATION</b>	<b>IL ROUTE 2 TRAFFIC CONTROL DETAILS</b>			F.A.P. RTE.	SECTION	COUNTY	TOTAL SHEETS	SHEET NO.
ca:\pw\work\FWIDOT\GRANTPM\dms31213\d066889pl.dgn	PLOT SCALE = 20,0000' / IN.	DRAWN -	REVISED -					742	37R-4	OGLE	867	458
PLOT DATE = Tue Mar 30 09:22:10 2010	DATE -	CHECKED -	REVISED -		CONTRACT NO. 64E17			ILLINOIS FED. AID PROJECT				
		DATE -	REVISED -		SCALE:	SHEET NO.	OF SHEETS	STA.	TO STA.			

# TRAFFIC CONTROL DETAILS

ACCORDING TO STANDARD 701201 →

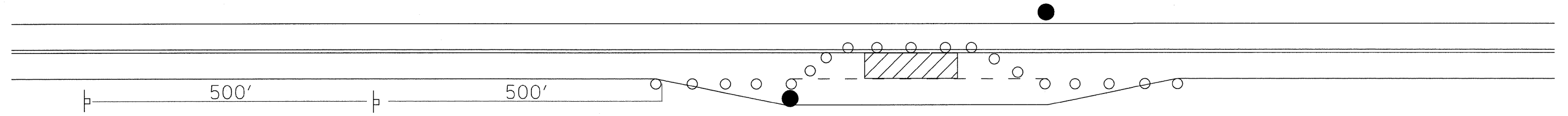

## GENERAL NOTES

THIS DETAIL IS TO BE USED IN CONJUNCTION WITH THE APPLICABLE TRAFFIC CONTROL AND PROTECTION STANDARD.

THIS TRAFFIC CONTROL DETAIL SHALL BE INCLUDED IN THE COST OF SPECIFIED TRAFFIC CONTROL STANDARDS OR ITEMS.

○ DRUMS OR BARRICADES AT 50' CTS FOR FIRST 250'.  
ADDITIONAL DEVICES MAY BE PLACED AT 100' CTS.

 WORK AREA

● FLAGGER (REQUIRED FOR SPEEDS >40 MPH)

NOTE: STANDARDS 701301 AND 701306  
SHALL NOT BE USED WITHIN 500 FEET  
OF THE TRANSITION.

FILE NAME =	USER NAME = grantpm	DESIGNED -	REVISED -	<b>STATE OF ILLINOIS DEPARTMENT OF TRANSPORTATION</b>	<b>IL ROUTE 2 TRAFFIC CONTROL DETAILS</b>			F.A.P. RTE.	SECTION	COUNTY	TOTAL SHEETS	SHEET NO.
or\pwork\PIWIDOT\GRANTPM\dms31213\06628apl.dgn	PLOT SCALE = 20.0000' / IN.	DRAWN -	REVISED -					742	37R-4	OGLE	867	459
PLOT DATE = Tue Mar 30 09:22:11 2010	DATE -	CHECKED -	REVISED -		CONTRACT NO. 64E17			ILLINOIS FED. AID PROJECT				
		DATE -	REVISED -		SCALE:	SHEET NO.	OF SHEETS	STA.	TO STA.			

# TRAFFIC CONTROL DETAILS

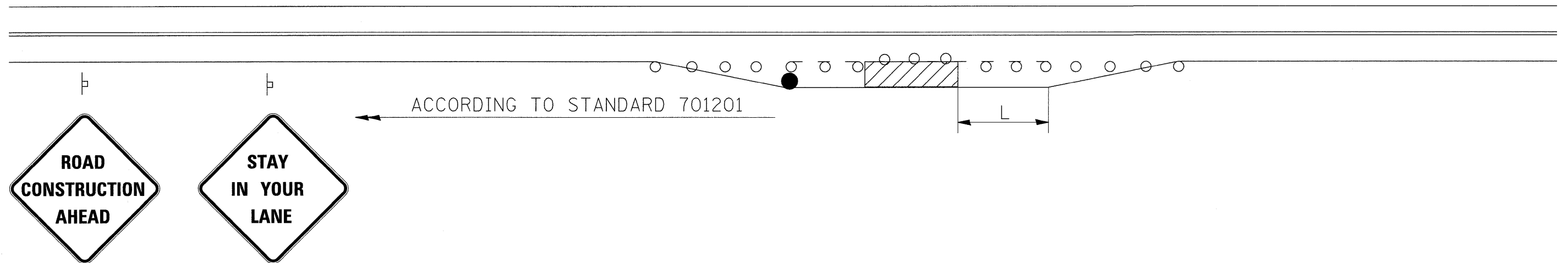

## GENERAL NOTES

○ DRUMS OR BARRICADES AT 50' CTS FOR FIRST 250'.  
ADDITIONAL DEVICES MAY BE PLACED AT 100' CTS.

 WORK AREA

● FLAGGER (REQUIRED FOR SPEEDS >40 MPH)

LANE CLOSURE MAY BE ENDED AFTER WORK AREA  
IF THERE IS AT LEAST 2500 FEET WHEN SPEED  
IS >40MPH OR 1500 FEET FOR ALL OTHER SPEEDS.

THIS TRAFFIC CONTROL DETAIL SHALL BE INCLUDED  
IN THE COST OF SPECIFIED TRAFFIC CONTROL  
STANDARDS OR ITEMS.

FILE NAME =	USER NAME = grantpm	DESIGNED -	REVISED -	<b>STATE OF ILLINOIS DEPARTMENT OF TRANSPORTATION</b>	<b>IL ROUTE 2 TRAFFIC CONTROL DETAILS</b>	F.A.P. RTE.	SECTION	COUNTY	TOTAL SHEETS	SHEET NO.	
os:\pwwork\VPWIDOT\GRANTPM\dms31213\006608apl.dgn	PLOT SCALE = 20.0000' / IN.	DRAWN -	REVISED -			742	37R-4	OGLE	867	460	
	PLOT DATE = Tue Mar 30 09:22:11 2010	CHECKED -	REVISED -			CONTRACT NO. 64E17		ILLINOIS FED. AID PROJECT			
		DATE -	REVISED -			SCALE:	SHEET NO. OF SHEETS	STA.	TO STA.		

# TRAFFIC CONTROL DETAILS

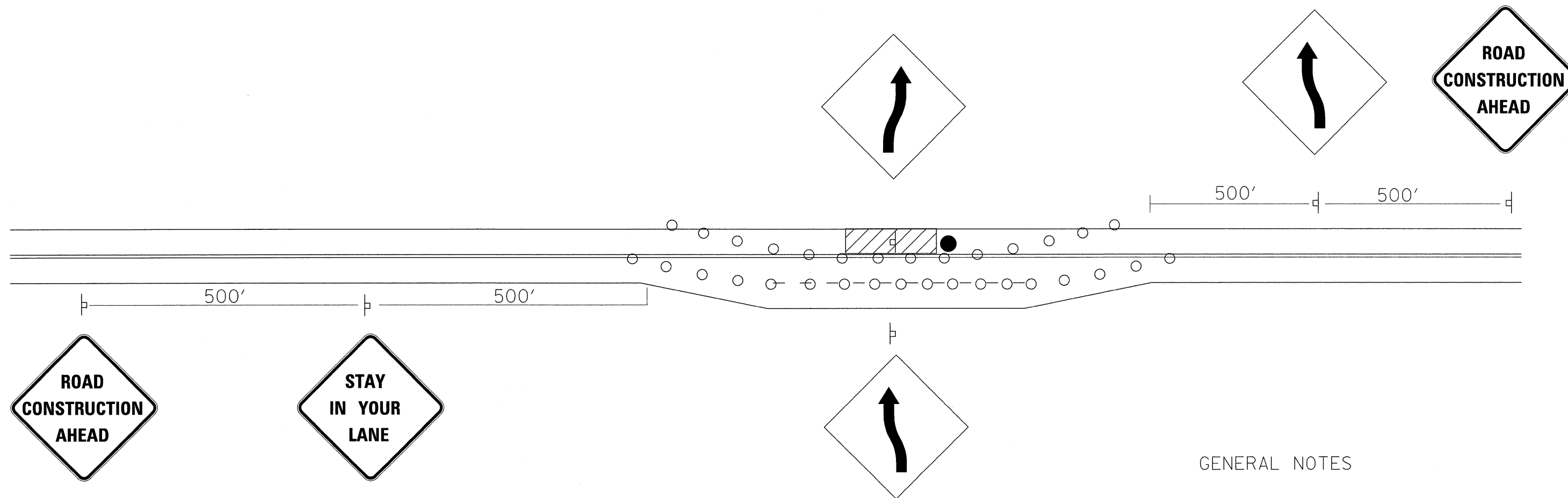

## GENERAL NOTES

THIS DETAIL IS TO BE USED IN CONJUNCTION WITH THE APPLICABLE TRAFFIC CONTROL AND PROTECTION STANDARD.

THIS TRAFFIC CONTROL DETAIL SHALL BE INCLUDED IN THE COST OF SPECIFIED TRAFFIC CONTROL STANDARDS OR ITEMS.

NOTE: STANDARDS 701301 AND 701306 SHALL NOT BE USED WITHIN 500 FEET OF THE TRANSITION.

○ DRUMS OR BARRICADES AT 50' CTS FOR FIRST 250'. ADDITIONAL DEVICES MAY BE PLACED AT 100' CTS.

 WORK AREA

● FLAGGER (REQUIRED FOR SPEEDS >40 MPH)

FILE NAME =	USER NAME = grantpm	DESIGNED -	REVISED -	<b>STATE OF ILLINOIS DEPARTMENT OF TRANSPORTATION</b>	<b>IL ROUTE 2 TRAFFIC CONTROL DETAILS</b>				F.A.P. RTE.	SECTION	COUNTY	TOTAL SHEETS	SHEET NO.
ca\pw_work\PIWIDOT\GRANTPM\dms31213\066828apl.dgn		DRAWN -	REVISED -		742	37R-4	OGLE	867	461				
	PLOT SCALE = 20.0000' / IN.	CHECKED -	REVISED -		SCALE:	SHEET NO.	OF SHEETS	STA.	TO STA.	CONTRACT NO. 64E17			
	PLOT DATE = Tue Mar 30 09:22:11 2010	DATE -	REVISED -		ILLINOIS FED. AID PROJECT								

# TRAFFIC CONTROL DETAILS

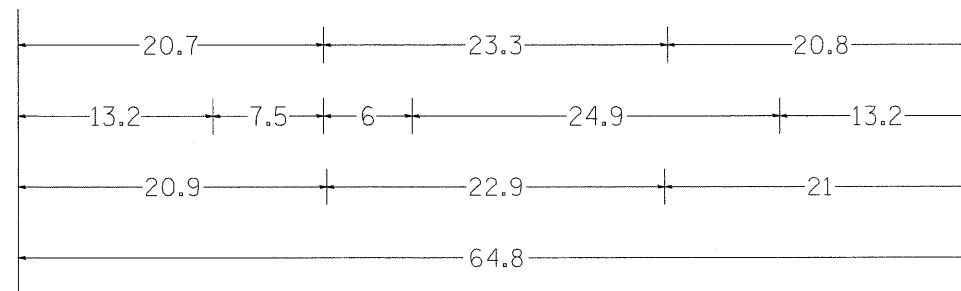
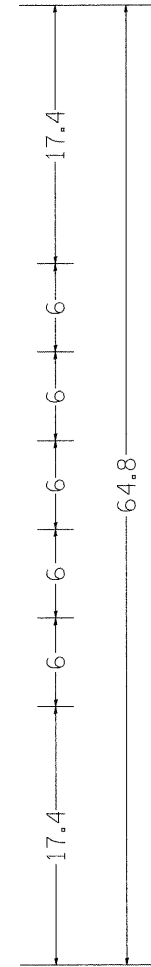

48.0" across sides 3.8" Radius, 1.0" Border, 0.6" Indent, Black on Orange  
 "STAY" E Mod; "IN YOUR" E Mod; "LANE" E Mod;  
 Table of letter and object lefts.

S	T	A	Y
20.7	26.8	31.6	38.0

I	N	Y	O	U	R
13.2	15.9	26.7	33.9	40.5	46.8

L	A	N	E
20.9	25.8	33.1	39.4

# DETOUR ROUTE



CITY OF BYRON

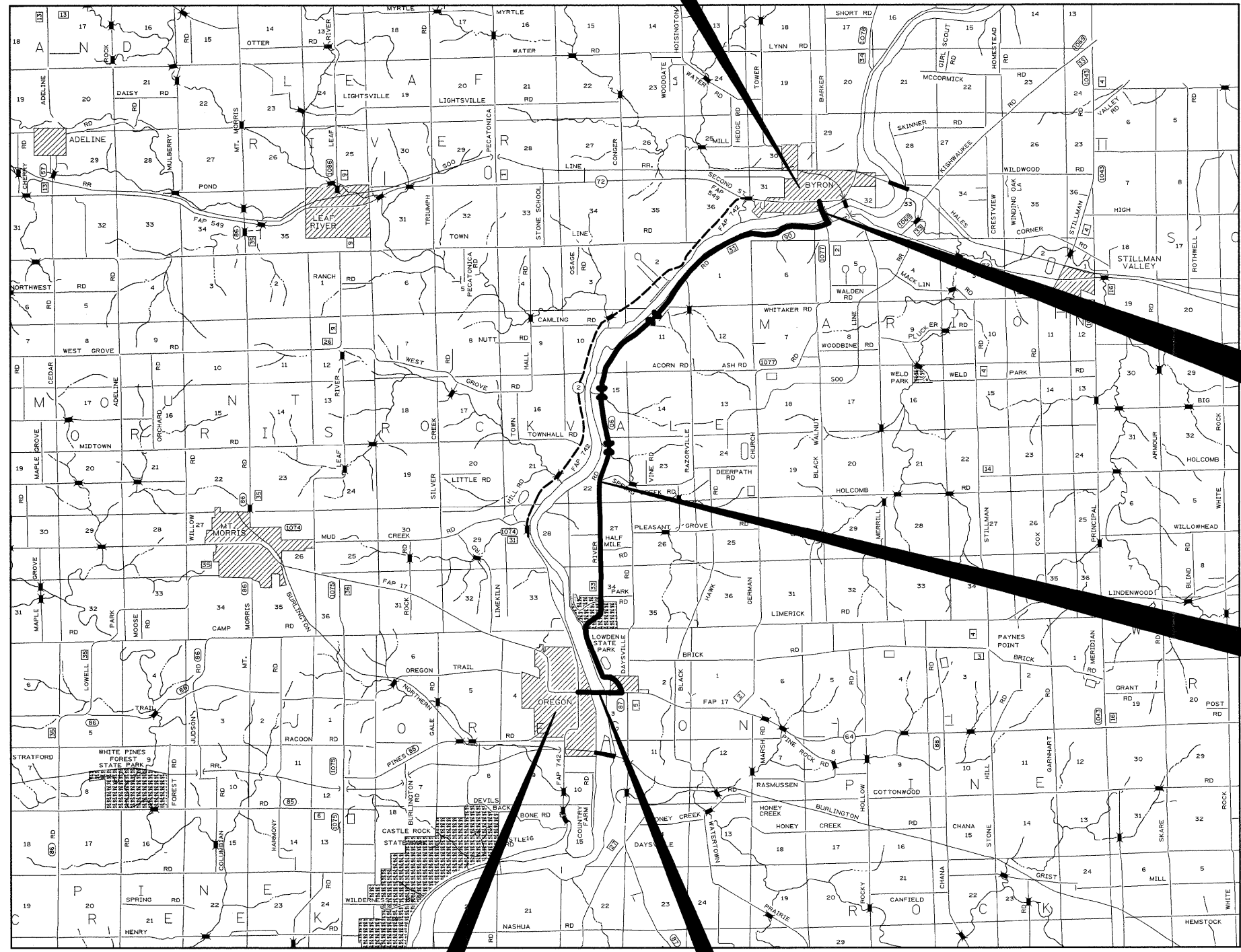

IL RTE 172

RIVER ROAD

VILLAGE OF OREGON

IL RTE 64

FILE NAME =	USER NAME = grantpm	DESIGNED -	REVISED -	STATE OF ILLINOIS DEPARTMENT OF TRANSPORTATION	IL RTE 2 DETOUR ROUTE			F.A.P. RTE.	SECTION	COUNTY	TOTAL SHEETS	SHEET NO.
c:\pw\work\PM\IDOT\GRANTPM\dms31213\d06628apl.dgn		DRAWN -	REVISED -		742	37R-4	OGLE	867	463			
	PLOT SCALE = 50.0000' / IN.	CHECKED -	REVISED -					CONTRACT NO. 64E17				
	PLOT DATE = Tue Mar 30 09:22:12 2010	DATE -	REVISED -		SCALE:	SHEET NO.	OF SHEETS	STA.	TO STA.	ILLINOIS FED. AID PROJECT		

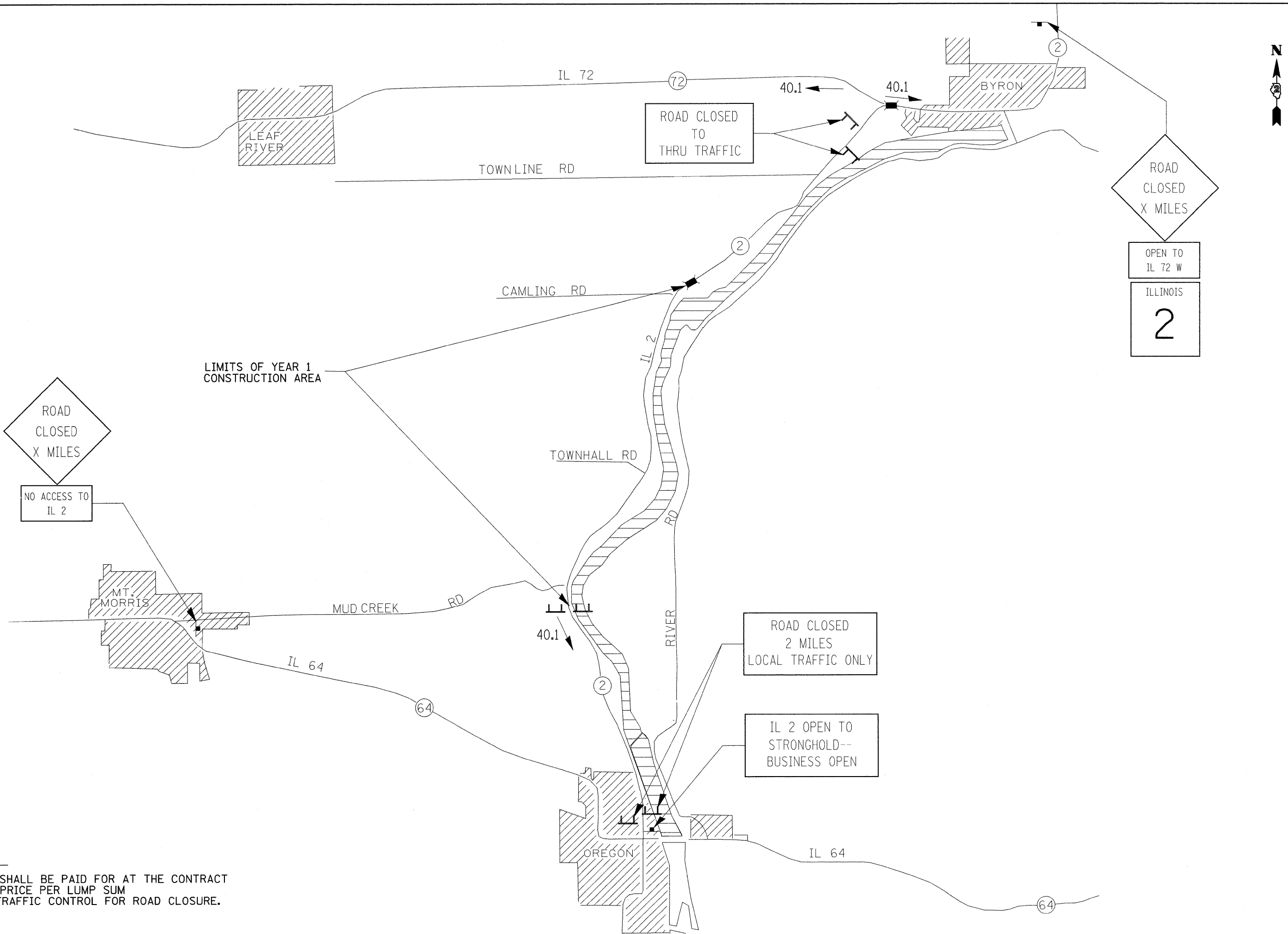

**NOTE:**  
 THIS SHALL BE PAID FOR AT THE CONTRACT  
 UNIT PRICE PER LUMP SUM  
 FOR TRAFFIC CONTROL FOR ROAD CLOSURE.

FILE NAME =	USER NAME = grantpm	DESIGNED -	REVISED -	<b>STATE OF ILLINOIS DEPARTMENT OF TRANSPORTATION</b>	<b>IL ROUTE 2 YEAR 1 -- ROAD CLOSURE DETAIL</b>			F.A.P. RTE.	SECTION	COUNTY	TOTAL SHEETS	SHEET NO.
cr\pw_work\PIWIDOT\GRANTPM\dms31213\d066	08spl.dgn	DRAWN -	REVISED -		742	37R-4	OGLE	867	464			
PLOT SCALE = 50.0000' / IN.		CHECKED -	REVISED -		SCALE: SHEET NO. OF SHEETS STA. TO STA.			CONTRACT NO. 64E17				
PLOT DATE = Tue Mar 30 09:22:26 2010		DATE -	REVISED -		ILLINOIS FED. AID PROJECT							



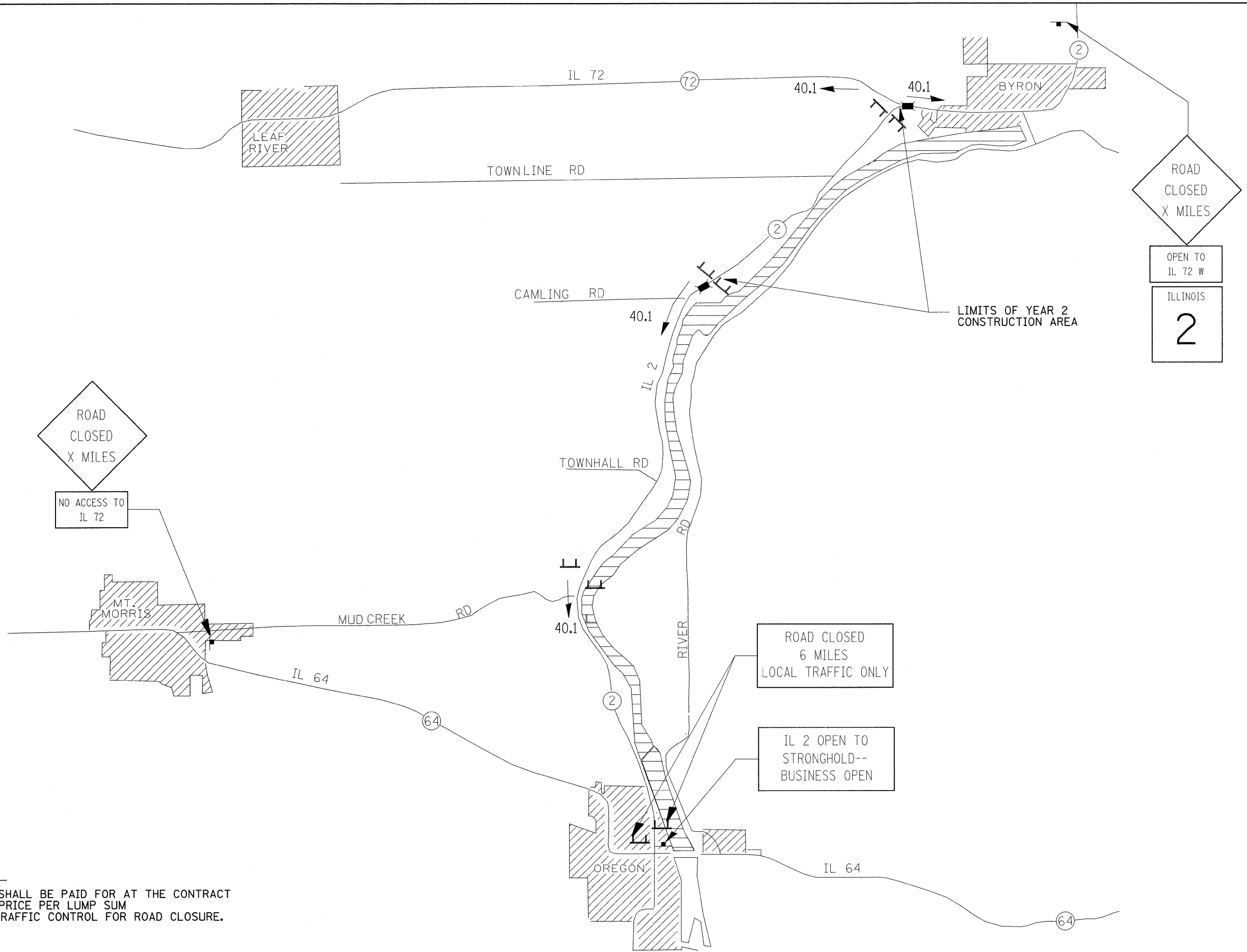

**NOTE:**  
 THIS SHALL BE PAID FOR AT THE CONTRACT  
 UNIT PRICE PER LUMP SUM  
 FOR TRAFFIC CONTROL FOR ROAD CLOSURE.

FILE NAME =	USER NAME = grantpm	DESIGNED -	REVISED -	<b>STATE OF ILLINOIS DEPARTMENT OF TRANSPORTATION</b>	<b>IL ROUTE 2 YEAR 2 — ROAD CLOSURE DETAIL</b>			F.A.P. RTE. 742	SECTION 37R-4	COUNTY OGLE	TOTAL SHEETS 867	SHEET NO. 465
es:\pw_work\VPWIDOT\GRANTPM\dms31213\086528apl.dgn	PLOT SCALE = 50.0000' / IN.	DRAWN -	REVISED -		SCALE:	SHEET NO.	OF	SHEETS	STA.	TO STA.	CONTRACT NO. 64E17	
PLOT DATE = Tue Mar 30 09:22:28 2010	DATE -	CHECKED -	REVISED -		ILLINOIS FED. AID PROJECT							

# SIGNING DETAILS

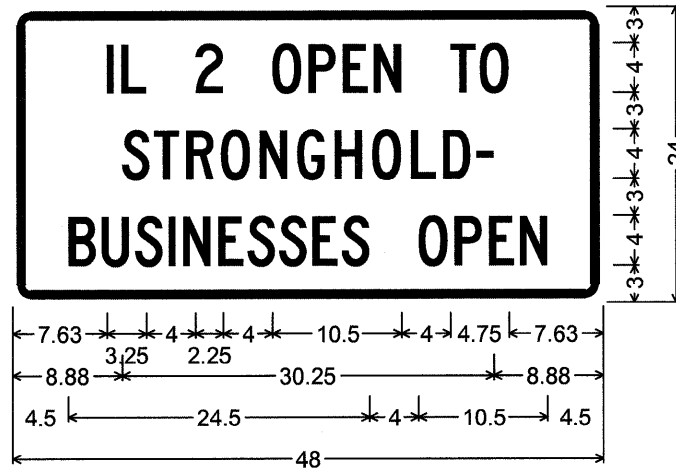

1.50" Radius, 0.63" Border, 0.38" Indent, Black on Orange;  
 [IL 2 OPEN TO] White C 2K 70% spacing;  
 [STRONGHOLD-] White C 2K;  
 [BUSINESSES OPEN] White C 2K 70% spacing;  
 Table of letter and object lefts.

I	L	2	O	P	E	N				
7.63	8.88	14.88	21.13	24.00	26.88	29.38				
T	O									
35.63	38.00									
S	T	R	O	N	G	H	O	L	D	-
8.88	11.50	14.13	17.00	20.13	23.13	26.13	29.25	32.38	35.00	37.75
B	U	S	I	N	E	S	S	E	S	
4.50	7.25	10.00	12.63	13.88	16.75	19.13	21.63	24.38	26.75	
O	P	E	N							
33.00	35.88	38.75	41.25							

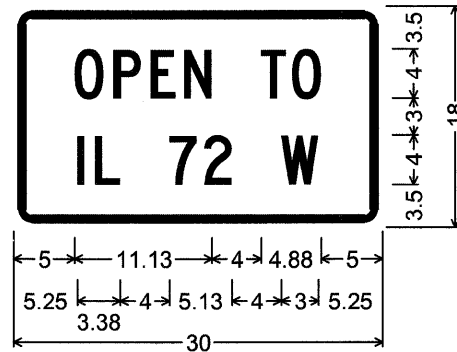

1.50" Radius, 0.63" Border, 0.38" Indent, Black on Orange;  
 [OPEN TO] C 2K;  
 [IL 72 W] C 2K;  
 Table of letter and object lefts.

O	P	E	N	
5.00	8.13	11.13	13.88	
T	O			
20.13	22.63			
I	L	7	2	W
5.25	6.63	12.63	15.50	21.75

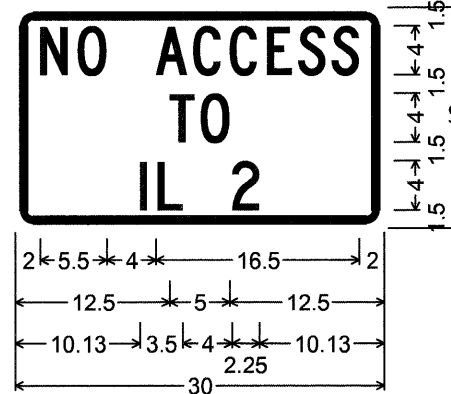

1.50" Radius, 0.63" Border, 0.38" Indent, Black on Orange;  
 [NO ACCESS] C 2K;  
 [TO] C 2K; [IL 2] C 2K;  
 Table of letter and object lefts.

N	O				
2.00	5.13				
A	C	C	E	S	S
11.50	14.50	17.50	20.50	23.00	25.75
T	O				
12.50	15.13				
I	L	2			
10.13	11.63	17.63			

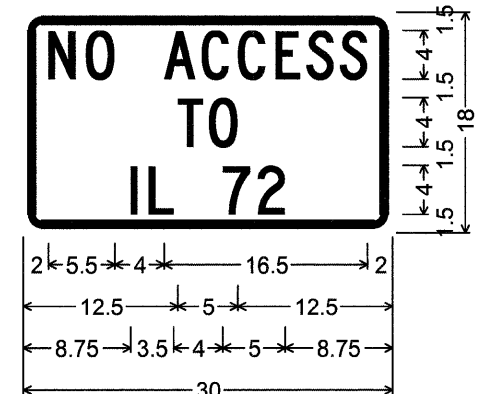

1.50" Radius, 0.63" Border, 0.38" Indent, Black on Orange;  
 [NO ACCESS] C 2K;  
 [TO] C 2K; [IL 72] C 2K;  
 Table of letter and object lefts.

N	O				
2.00	5.13				
A	C	C	E	S	S
11.50	14.50	17.50	20.50	23.00	25.75
T	O				
12.50	15.13				
I	L	7	2		
8.75	10.13	16.25	19.00		

## NOTES

TO BE PAID FOR USING TRAFFIC CONTROL STANDARD FOR ROAD CLOSURE

FILE NAME =	USER NAME = grantpm	DESIGNED -	REVISED -	<b>STATE OF ILLINOIS DEPARTMENT OF TRANSPORTATION</b>	<b>SIGNING DETAILS</b>	F.A.P. RTE. 742	SECTION 37R-4	COUNTY OGLE	TOTAL SHEETS 867	SHEET NO. 466		
os:\pwork\PIWIDOT\GRANTPM\dms31213\086628apl.dgn	PLOT SCALE = 50.0000' / IN.	DRAWN -	REVISED -			SCALE: SHEET NO. OF SHEETS STA. TO STA.		CONTRACT NO. 64E17				
PLOT DATE = Tue Mar 30 09:22:30 2010	DATE -	CHECKED -	REVISED -			ILLINOIS FED. AID PROJECT						
		DATE -	REVISED -									

# CURB AND GUTTER OUTLET, SPECIAL

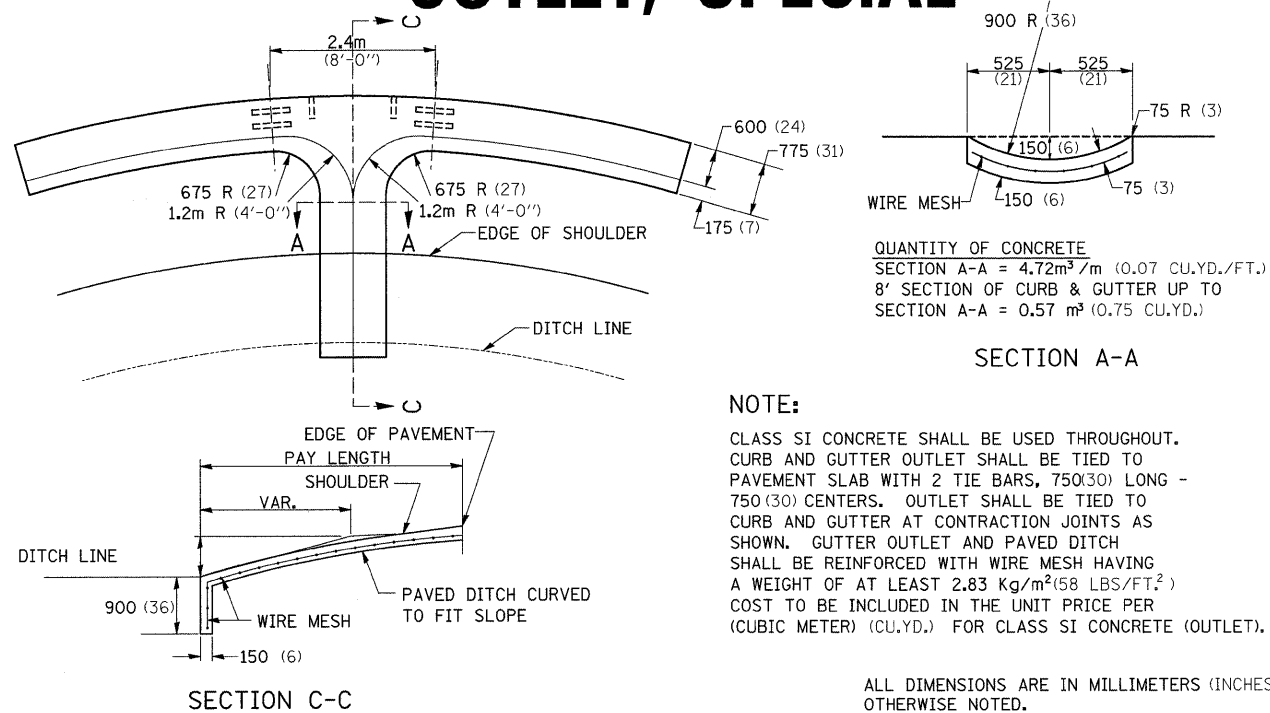

CURB AND GUTTER OUTLET, SPECIAL 18.4

# GRADING AROUND WINGWALLS

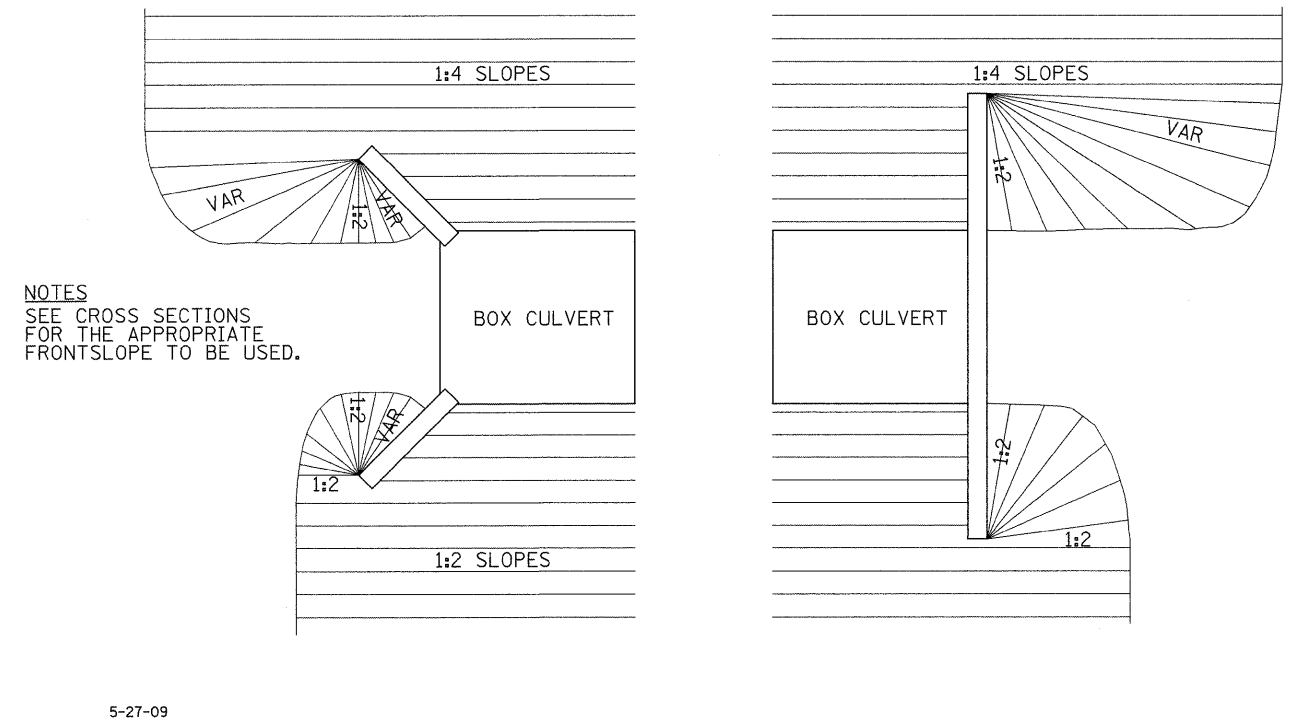

GRADING AROUND WINGWALLS 20.4

# CONCRETE GUTTER, TYPE A (MODIFIED)

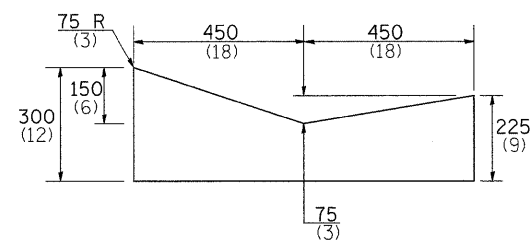

NOTES:  
THIS WORK SHALL BE DONE IN ACCORDANCE WITH THIS DETAIL AND STANDARD 606101  
THIS WORK SHALL BE PAID FOR AT THE CONTRACT UNIT PRICE PER METER (FOOT) FOR CONCRETE GUTTER, TYPE A (MODIFIED).

ALL DIMENSIONS ARE IN MILLIMETERS (INCHES) UNLESS OTHERWISE NOTED.

REVISED - 5-4-94

CONCRETE GUTTER, TYPE A (MODIFIED) 36.4

# DELINEATOR AND POST ORIENTATION

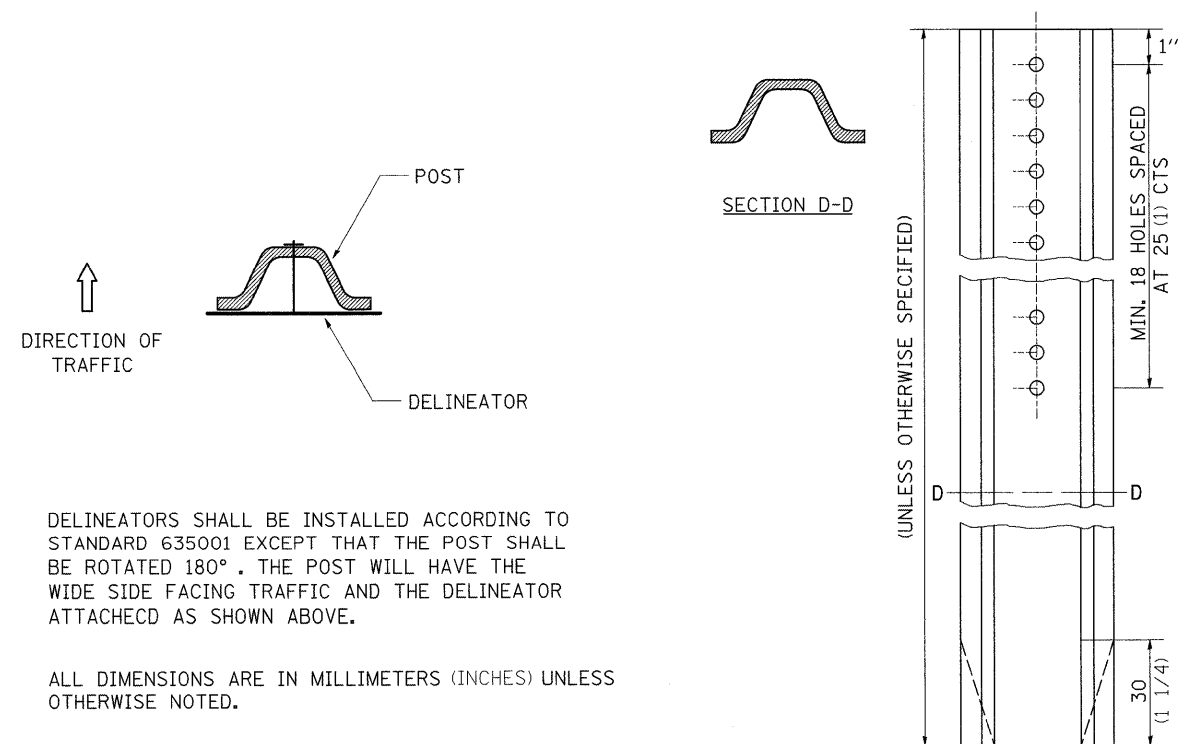

REVISED - 11-01-07

REVISED -	REGION 2 / DISTRICT 2 STANDARD	F.A.P. RTE.	SECTION	COUNTY	TOTAL SHEETS	SHEET NO.
REVISED -		742	37R-4	OGLE	867	467
REVISED -		SCALE: 50.0000' / 1" SHEET NO. OF SHEETS STA. TO STA.		CONTRACT NO. 64E17		
REVISED -		FED. ROAD DIST. NO. ILLINOIS FED. AID PROJECT				
REVISED -		PLOT DATE = Tue Mar 30 09:22:30 2010				

DELINEATOR AND POST ORIENTATION 37.4

# TYPICAL BENCHING ON EXISTING EMBANKMENT

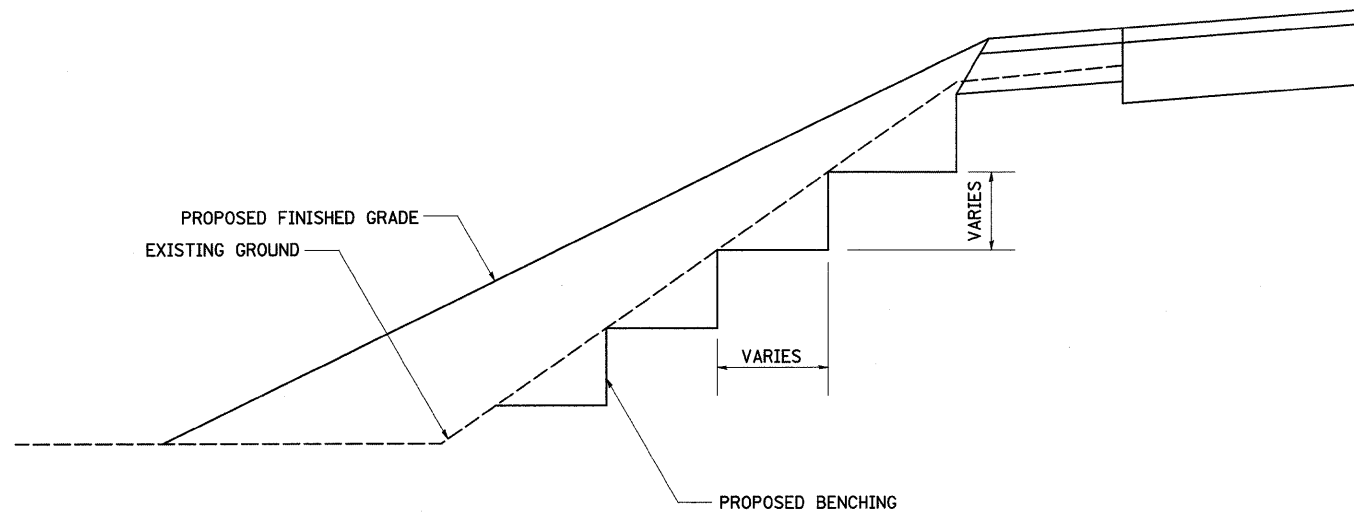

REVISED - 2-22-06

**TYPICAL BENCHING ON EXISTING EMBANKMENT 50.4**

# LAND SECTION & REFERENCE MARKERS

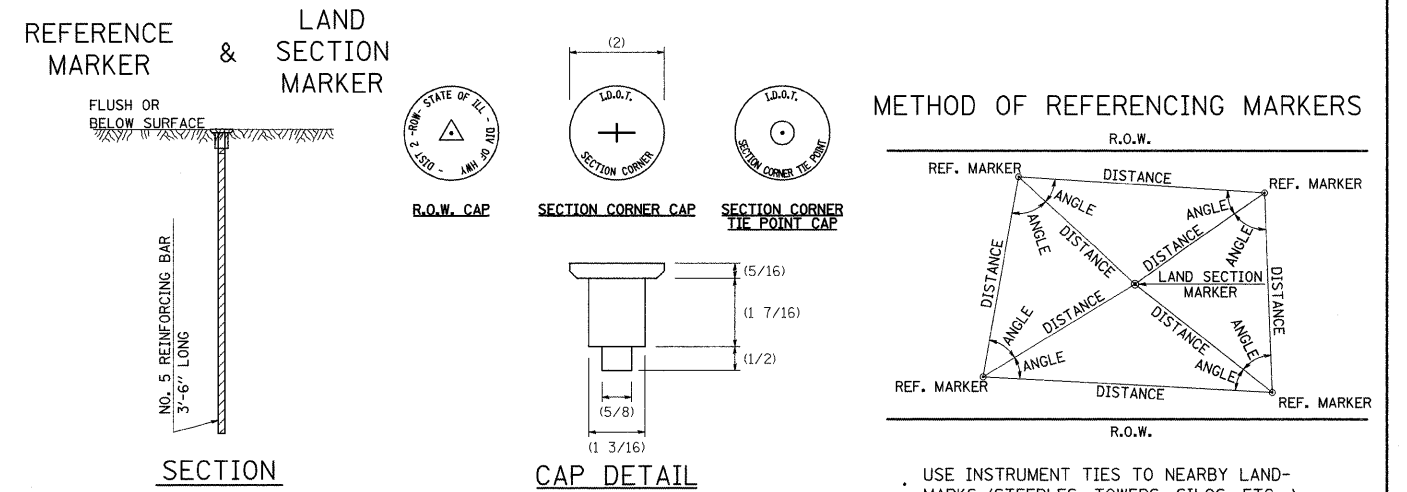

## METHOD OF REFERENCING POINTS

REFERENCE MARKERS SHALL BE USED TO TIE IN PERMANENT LAND SECTION AND 1/4 SECTION CORNERS. WHERE LAND SECTION MARKERS FALL IN THE SHOULDERS OR GRAVEL SURFACES, THE TOP OF THE BAR SHALL BE KEPT 3" BELOW THE SURFACE. LAND SECTION MARKERS LOCATED IN TRAFFIC LANES SHALL BE REPLACED BY CORE DRILL AND RESETTING PIN.

ALUMINUM CAPS SHALL BE PLACED ON TOP OF THE REINFORCEMENT BAR. THERE ARE 3 TYPES OF CAPS, ONE FOR THE RIGHT-OF-WAY CORNERS, ONE FOR THE SECTION CORNERS AND ONE FOR THE SECTION CORNER TIE POINTS. THE CAPS WILL BE SUPPLIED BY THE SURVEYOR WHO IS RESPONSIBLE FOR MONUMENTING CORNERS.

REVISED - 03-05-10

## METHOD OF REFERENCING MARKERS

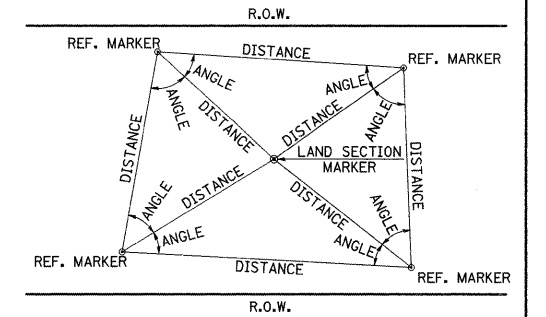

- USE INSTRUMENT TIES TO NEARBY LAND-MARKS (STEEPLES, TOWERS, SILOS, ETC...)
- IN CULTIVATED FIELDS, SET 28" OR MORE BELOW GROUND SURFACE.
- IN FENCE LINE OR PROTECTED AREA SET TOP AT GROUND LEVEL SO AS NOT TO BE DISTURBED BY MOWING.

ALL DIMENSIONS ARE IN INCHES UNLESS OTHERWISE NOTED.

**LAND SECTION & REFERENCE MARKERS 63.4**

# INLET SPECIAL NO. 5

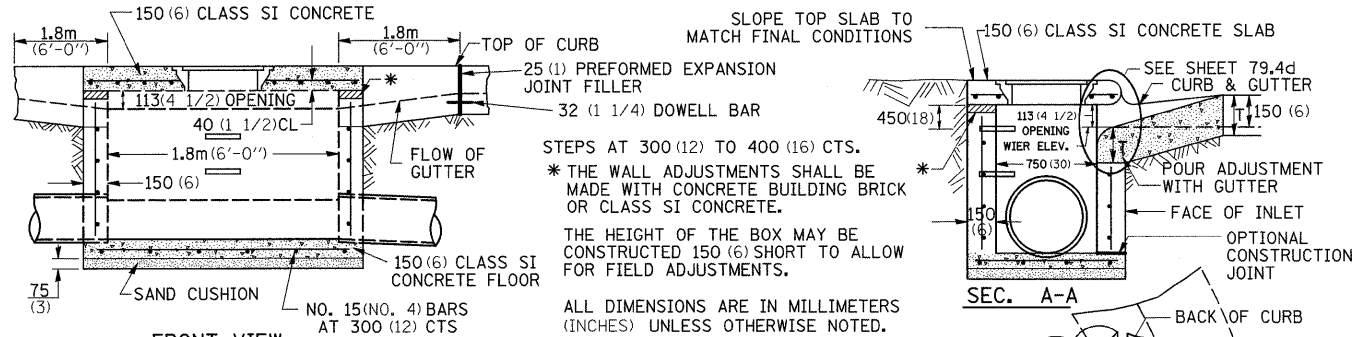

## NOTES

- SEE STANDARD 602701 FOR DETAILS OF STEPS. 25(1) PREFORMED EXPANSION JOINTS AS SHOWN SHALL BE PROVIDED ON EACH SIDE OF INLET.
- CLASS SI CONCRETE OR PRECAST CONCRETE SHALL BE USED THROUGHOUT.
- THE SIDE WALLS MAY BE BUILT AS PRECAST SEGMENTAL SECTIONS.
- REINFORCEMENT FOR INLET SPECIAL NO. 5 SHALL BE ACCORDING TO DISTRICT STANDARD 79.4e
- STEPS SHALL BE OMITTED WHEN DEPTH OF INLET IS LESS THAN 1.5 m (5 ft.)
- THE INLET SHALL BE CAST IN PLACE OR PRECAST.
- EXCEPT AS NOTED HEREON INLET SPECIAL NO. 5 SHALL BE CONSTRUCTED IN ACCORDANCE WITH SECTION 602 OF THE STANDARD SPECIFICATIONS.
- THE CONTRACT UNIT PRICE EACH FOR INLET SPECIAL NO. 5 SHALL INCLUDE THE COST OF FURNISHING AND INSTALLING THE FRAME, LID, REINFORCEMENT BARS, FLOOR AND TOP SLABS, CAST IRON STEPS (IF USED).
- THE CURB AND GUTTER WILL BE PAID FOR SEPARATELY AND WILL BE MEASURED THROUGH THE INLET.
- THE CURB AND GUTTER ADJACENT TO AND 1.8m (6 FT) ON EITHER SIDE OF THE INLET SHALL BE CONSTRUCTED AS SHOWN WITH NO ADDITIONAL COMPENSATION FOR THE TRANSITION.
- \*\* WHEN INLET IS CONSTRUCTED IN RETURN, THE TOP OF SLAB SHALL CONFORM TO THE RADIUS OF THE RETURN.

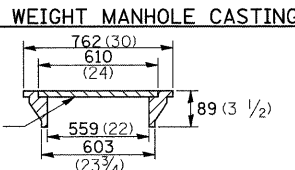

TOTAL WEIGHT 73 KG. (160 LBS.)

REVISED - 4-4-05

**INLET SPECIAL NO. 5 79.4b**

# INLET SPECIAL NO. 6

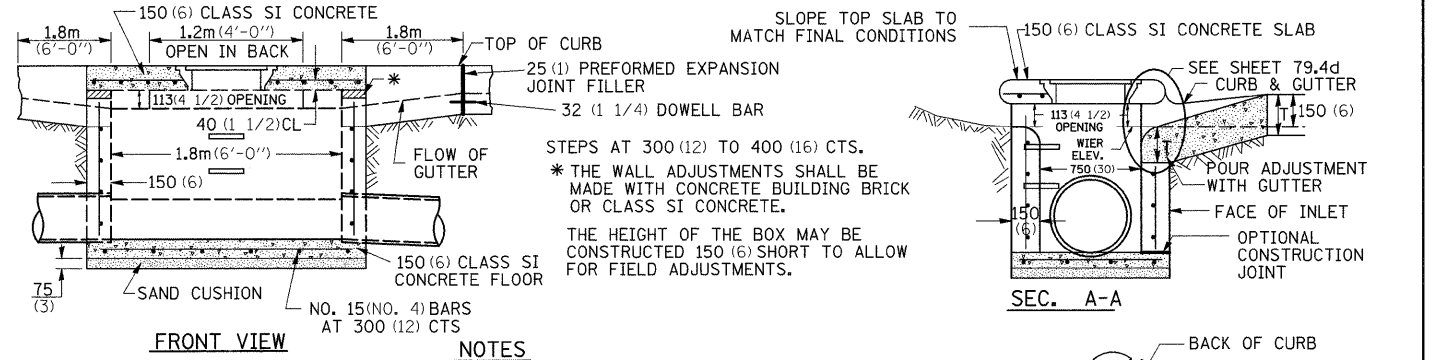

## NOTES

- SEE STANDARD 602701 FOR DETAILS OF STEPS. 25(1) PREFORMED EXPANSION JOINTS AS SHOWN SHALL BE PROVIDED ON EACH SIDE OF INLET.
- CLASS SI CONCRETE OR PRECAST CONCRETE SHALL BE USED THROUGHOUT.
- THE SIDE WALLS MAY BE BUILT AS PRECAST SEGMENTAL SECTIONS.
- REINFORCEMENT FOR INLET SPECIAL NO. 6 SHALL BE ACCORDING TO DISTRICT STANDARD 79.4e
- STEPS SHALL BE OMITTED WHEN DEPTH OF INLET IS LESS THAN 1.5 m (5 ft.)
- THE INLET SHALL BE CAST IN PLACE OR PRECAST.
- EXCEPT AS NOTED HEREON INLET SPECIAL NO. 6 SHALL BE CONSTRUCTED IN ACCORDANCE WITH SECTION 602 OF THE STANDARD SPECIFICATIONS.
- THE CONTRACT UNIT PRICE EACH FOR INLET SPECIAL NO. 6 SHALL INCLUDE THE COST OF FURNISHING AND INSTALLING THE FRAME, LID, REINFORCEMENT BARS, FLOOR AND TOP SLABS, CAST IRON STEPS (IF USED).
- THE CURB AND GUTTER WILL BE PAID FOR SEPARATELY AND WILL BE MEASURED THROUGH THE INLET.
- THE CURB AND GUTTER ADJACENT TO AND 1.8m (6 FT) ON EITHER SIDE OF THE INLET SHALL BE CONSTRUCTED AS SHOWN WITH NO ADDITIONAL COMPENSATION FOR THE TRANSITION.

## LIGHT WEIGHT MANHOLE CASTING

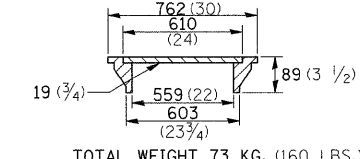

TOTAL WEIGHT 73 KG. (160 LBS.)

REVISED - 4-4-05

REVISED -	<b>REGION 2 / DISTRICT 2 STANDARD</b>	F.A.P. RTE.	SECTION	COUNTY	TOTAL SHEETS	SHEET NO.
REVISED -		742	37R-4	OGLE	867	468
REVISED -		CONTRACT NO. 64E17				
REVISED -		SCALE: 50.0000' / IN	SHEET NO.	OF	SHEETS	STA.

PLOT DATE = Tue Mar 30 09:22:31 2010

**INLET SPECIAL NO. 6 79.4c**

# NOSE TYPE FOR INLET TOP SLAB

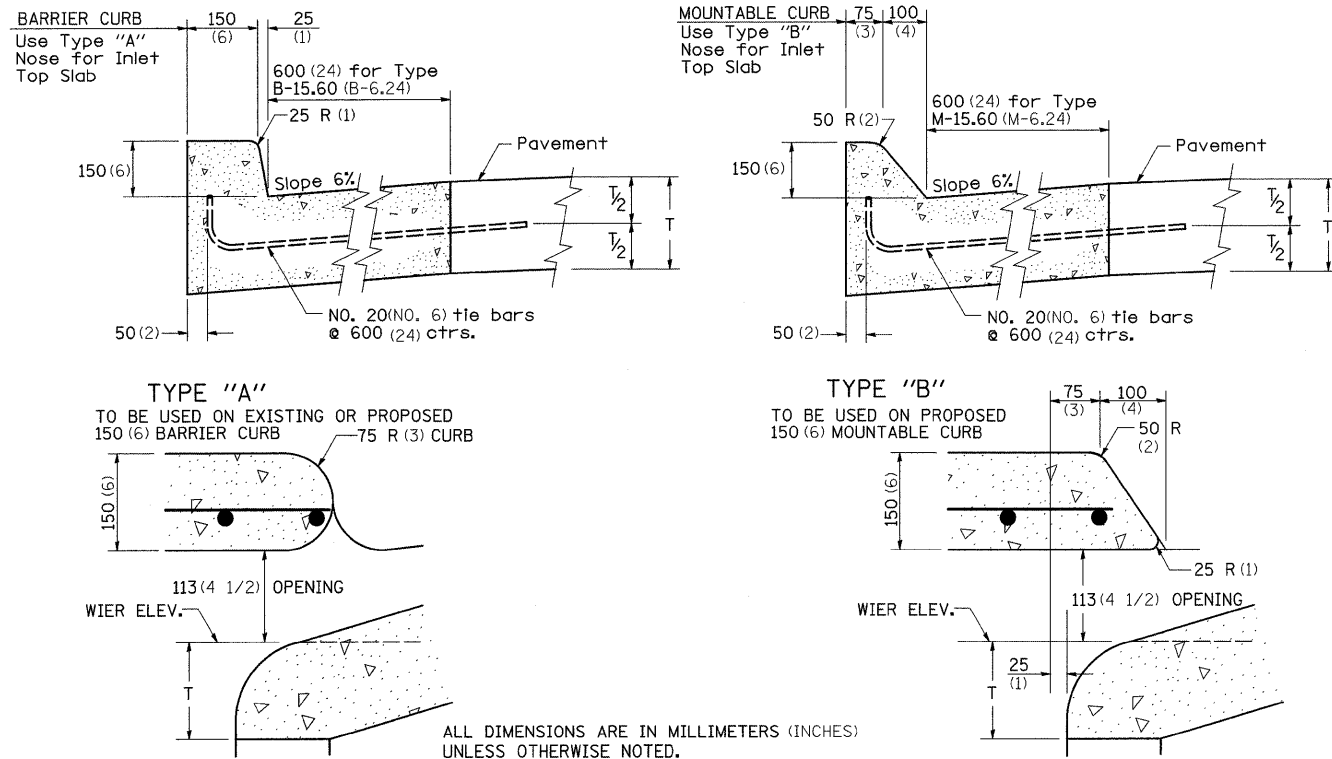

REVISED - 2-14-95

NOSE TYPE FOR INLET TOP SLAB 79.4d

# INLET SPECIAL NO. 3, 4, 5, 6 REINFORCEMENT DETAIL

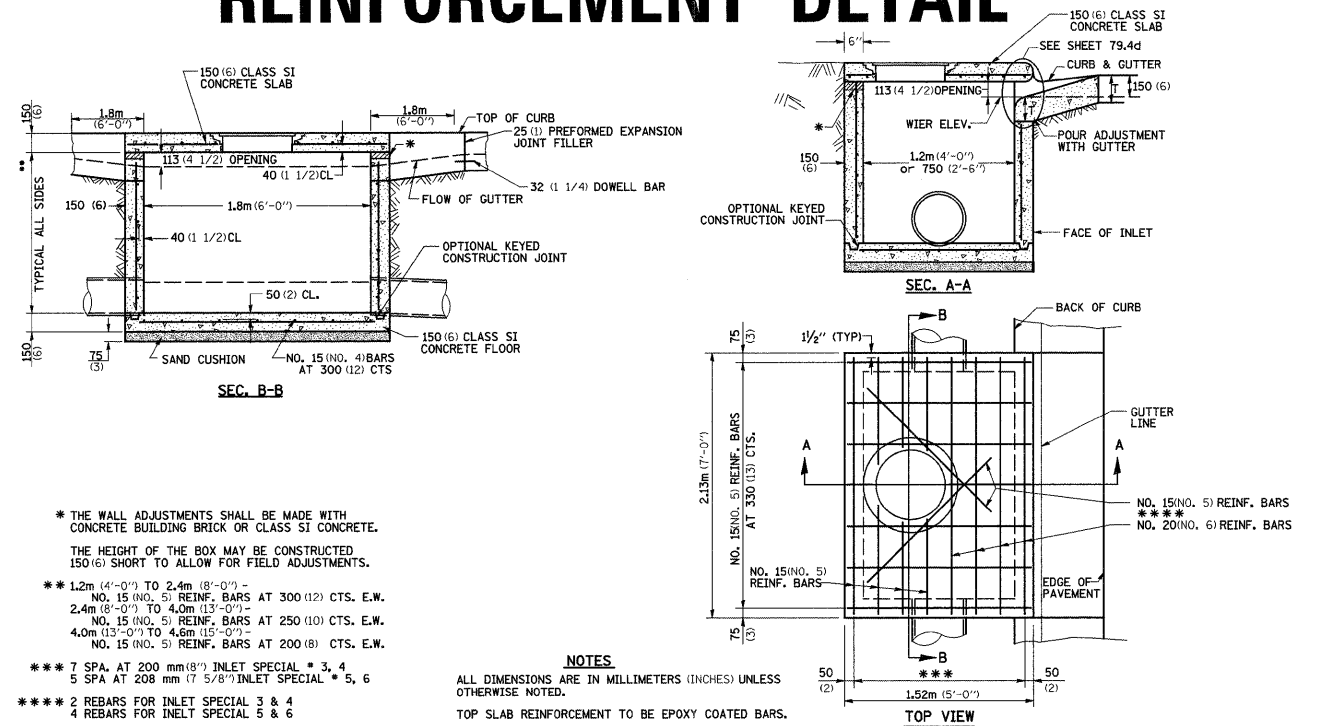

REVISED - 11-01-07

INLET SPECIAL NO. 3, 4, 5, 6 REINFORCEMENT DETAIL 79.4e

# DRAIN FOR AGGREGATE BASES IN URBAN AREAS

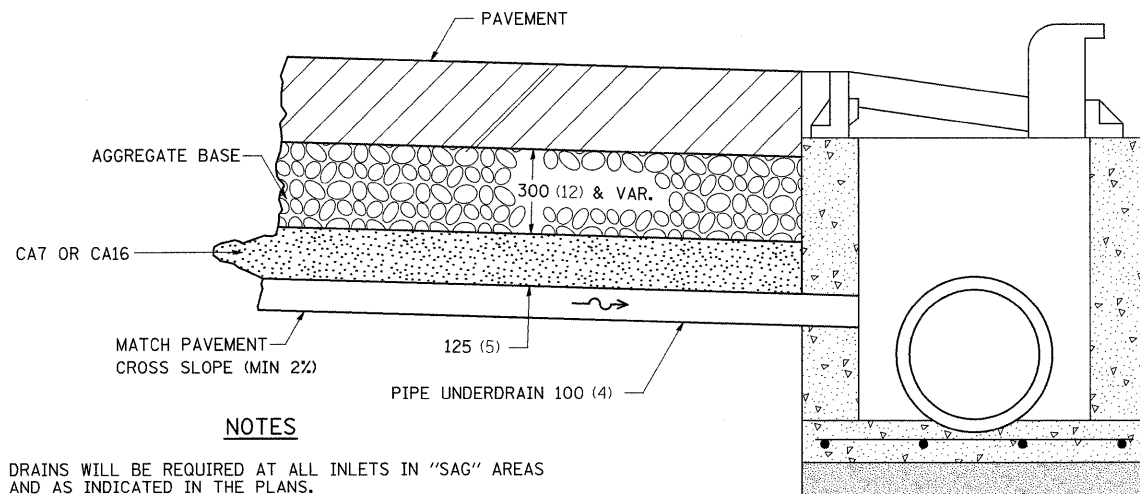

REVISED - 4-7-99

DRAIN FOR AGGREGATE BASES IN URBAN AREAS 88.4

# TREE REPLACEMENT SCHEDULE

CODE NUMBER	SCIENTIFIC NAME	COMMON NAME	SIZE	UNIT	QUANTITY
A2C022G3	TREE, CARYA ILLINOINENSIS	PECAN	CONTAINER GROWN, 3-GALLON	EACH	395
A2C040G3	TREE, PLATANUS OCCIDENTALIS	SYCAMORE	CONTAINER GROWN, 3-GALLON	EACH	395
A2C050G3	TREE, QUERCUS BICOLOR	SWAMP WHITE OAK	CONTAINER GROWN, 3-GALLON	EACH	395
A2C060G3	TREE, QUERCUS PALUSTRIS	PIN OAK	CONTAINER GROWN, 3-GALLON	EACH	498
A2001714	TREE, ACER SACCHARUM	SUGAR MAPLE	1-3/4" CALIPER, BALLED AND BURLAPPED	EACH	212
A2006714	TREE, QUERCUS MACROCARPA	BUR OAK	1-3/4" CALIPER, BALLED AND BURLAPPED	EACH	121
A2007114	TREE, QUERCUS RUBRA	RED OAK	1-3/4" CALIPER, BALLED AND BURLAPPED	EACH	212
B2001114	TREE, CERCIS CANADENSIS	EASTERN RED BUD	1-3/4" CALIPER, TREE FORM, BALLED AND BURLAPPED	EACH	121
B2004814	TREE, MALUS SARGENTII	SARGENT CRABAPPLE	1-3/4" CALIPER, TREE FORM, BALLED AND BURLAPPED	EACH	121
B2005014	TREE, MALUS SNOWDRIFT	SNOWDRIFT CRABAPPLE	1-3/4" CALIPER, TREE FORM, BALLED AND BURLAPPED	EACH	121

SEE GENERAL NOTES FOR ADDITIONAL TREE NOTES AND COMMITMENTS.

8-10-05

REVISED -	REGION 2 / DISTRICT 2 STANDARD	F.A.P. RTE.	SECTION	COUNTY	TOTAL SHEETS	SHEET NO.	
REVISED -		742	37R-4	OGLE	867	469	
REVISED -		SCALE: 50:0000' / 1"	SHEET NO.	OF SHEETS	STA.	TO STA.	FED. ROAD DIST. NO.
REVISED -							ILLINOIS FED. AID PROJECT
REVISED -							CONTRACT NO. 64E17

TREE REPLACEMENT SCHEDULE 90.4

# RUMBLE RESURFACING

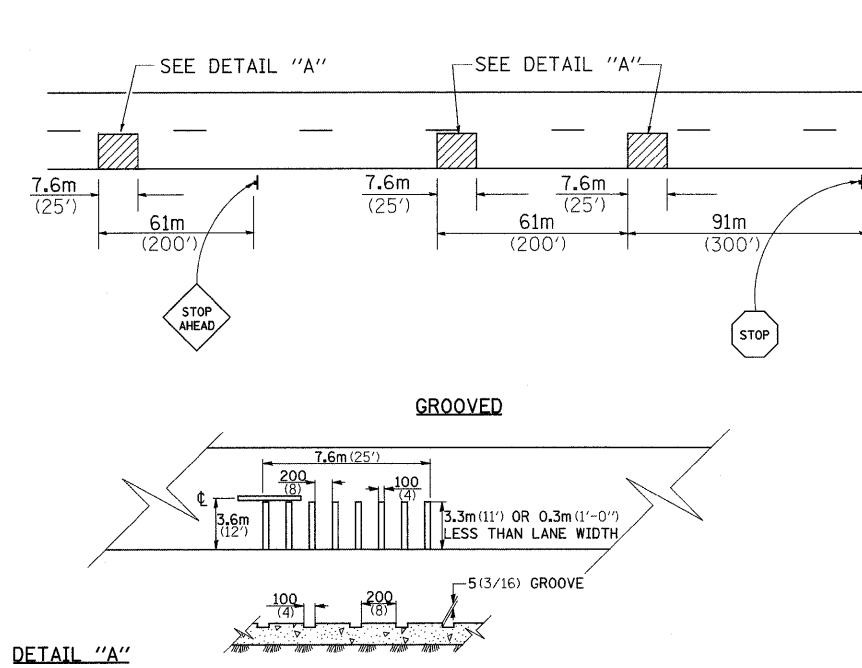

ALL DIMENSIONS ARE IN MILLIMETERS (INCHES) UNLESS OTHERWISE NOTED.

REVISED - 3-22-10

**RUMBLE RESURFACING 91.4**

# TYPICAL MARKING FOR PAINTED ISLANDS

NOTE:  
\* 45° TO LOCAL TAN.

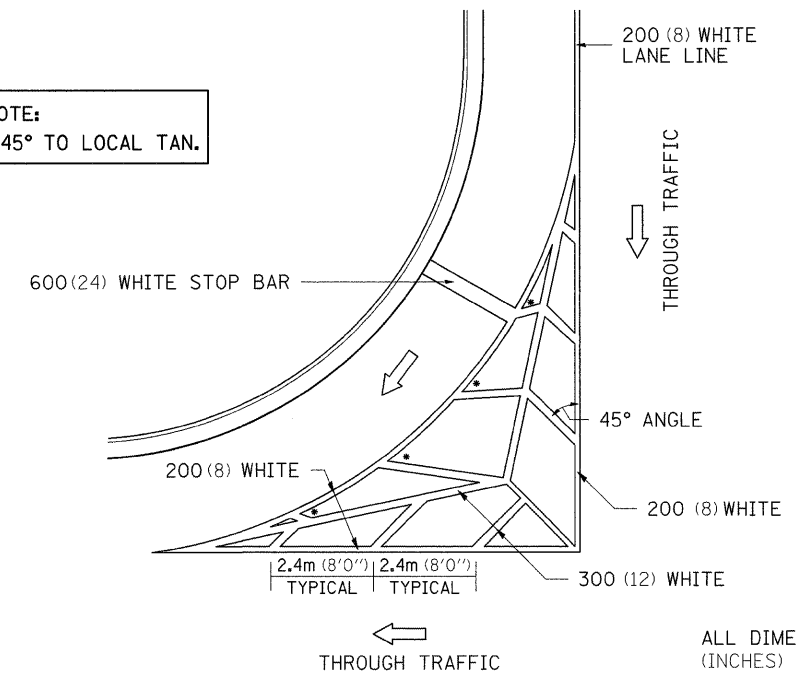

ALL DIMENSIONS ARE IN MILLIMETERS (INCHES) UNLESS OTHERWISE NOTED.

REVISED - 2-7-05

**TYPICAL MARKING FOR PAINTED ISLANDS 93.4**

# STOP LINE SIGN FOR TEMPORARY SIGNALS



SIZE: 600(24) x 600(24)  
100(4) CAPITAL LETTERS - BLACK  
13 (1/2) BORDER - BLACK  
WHITE REFLECTIVE - TYPE AP  
HIGH INTENSITY PRISMATIC SHEETING

**GENERAL NOTE:**

THIS SIGN SHALL BE INSTALLED AT THE STOP LINE AS DIRECTED BY ENGINEER.

ALL DIMENSIONS ARE IN MILLIMETERS (INCHES) UNLESS OTHERWISE NOTED.

REVISED - 1-22-07

**STOP LINE SIGN FOR TEMPORARY SIGNALS 99.4**

REVISED -	REGION 2 / DISTRICT 2 STANDARD				F.A.P. RTE.	SECTION	COUNTY	TOTAL SHEETS	SHEET NO.
REVISED -					742	37R-4	OGLE	867	470
REVISED -	SCALE: 50.0000' / 1" SHEET NO. OF SHEETS STA. TO STA.				CONTRACT NO. 64E17				
REVISED -					FED. ROAD DIST. NO. ILLINOIS FED. AID PROJECT				

PLOT DATE = Tue Mar 30 09:22:35 2010

# EROSION CONTROL DETAILS FOR SILT FENCE

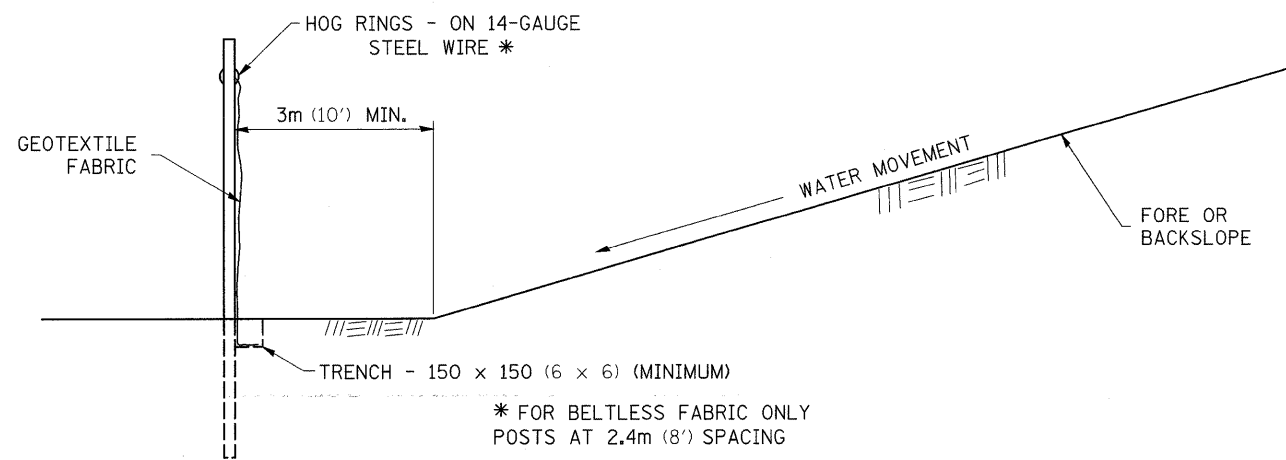
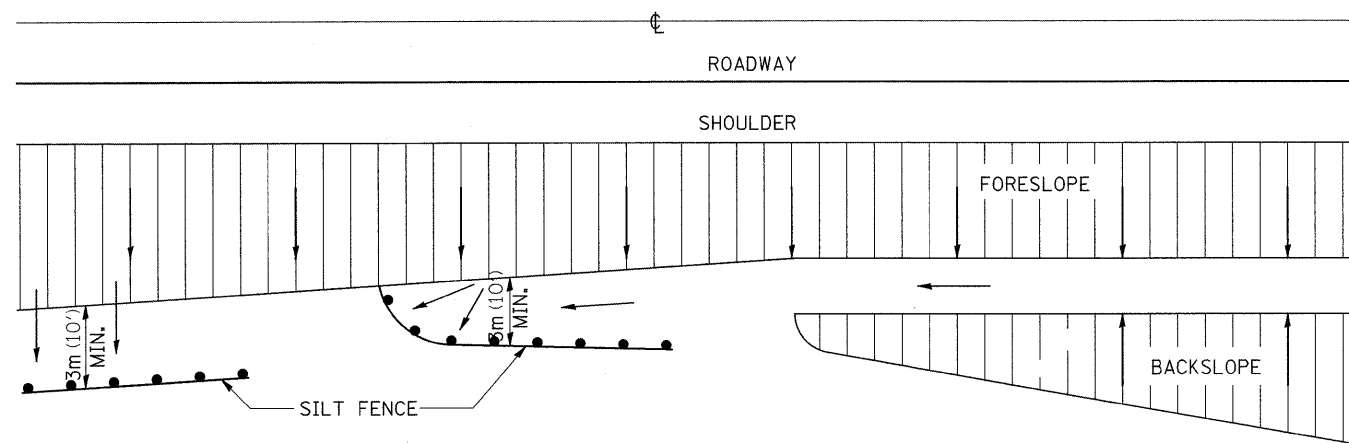

DETAILS OF SILT FENCE

ALL DIMENSIONS ARE IN MILLIMETERS (INCHES) UNLESS OTHERWISE NOTED.

REVISED - 10-22-01

# INFORMATIONAL WARNING SIGN (FOR NARROW TRAVEL LANES)

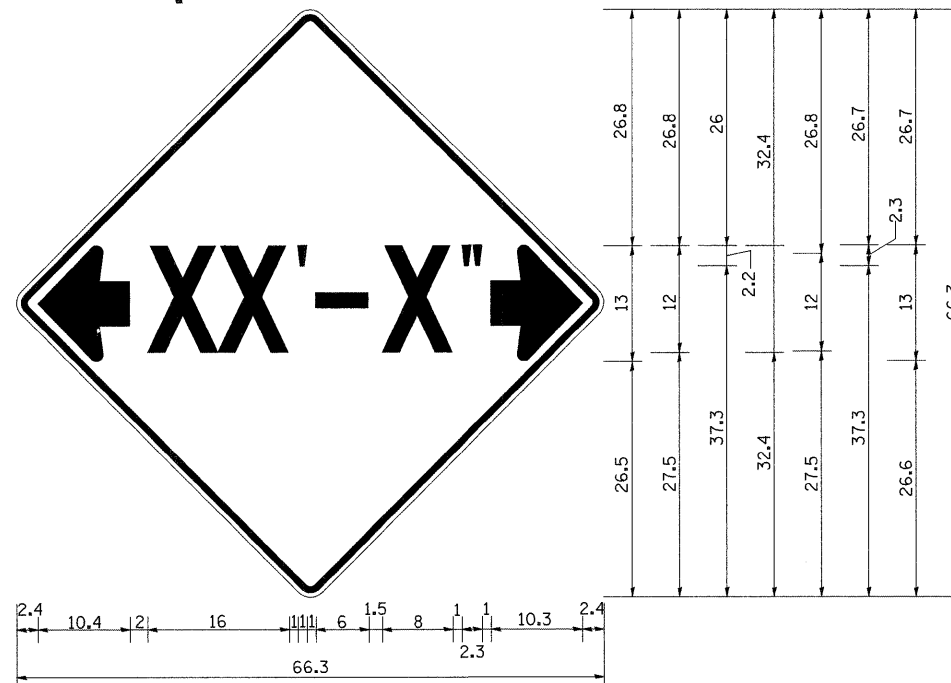

NOTES  
 W12-2 - Horizontal Clearance Sign  
 48.0" across sides, 1.9" Radius,  
 0.8" Border, 0.5" Indent, Black on  
 Orange; Standard Arrow Custom  
 10.4" X 8.1" 180° Black 11 Inch  
 D Series Lettering; Standard Arrow  
 Custom 10.4" X 8.1" 0°

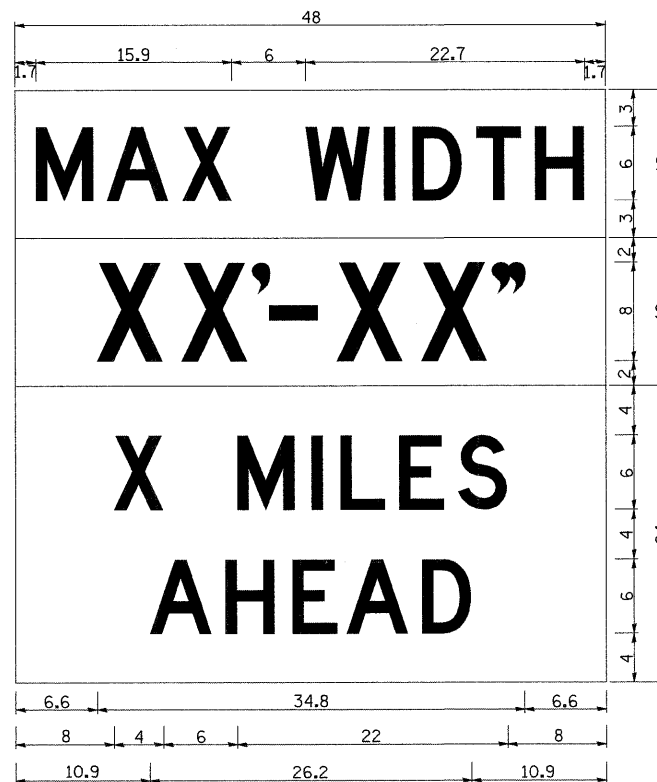

W12-I103 (Width Is 8D);  
 No border, Black on White;  
 [MAX WIDTH] D;

No border, Black on Orange;  
 [XX'-XX''] D;

No border, Black on White;  
 [X MILES] D; [AHEAD] D;

All work to furnish and install these signs shall be included in the cost of the Traffic Control Standards and shall not be paid for separately.

ALL DIMENSIONS ARE IN INCHES UNLESS OTHERWISE NOTED.

REVISED - 5-15-09	REGION/REGION/SECTION/STANDARD	F.A.P. RTE.	SECTION	COUNTY	TOTAL SHEETS	SHEET NO.
REVISED -		742	37R-4	OGLE	867	471
REVISED -		SCALE: 50,000' / 1" SHEET NO. OF SHEETS STA. TO STA.	CONTRACT NO. 64E17			
REVISED -		FED. ROAD DIST. NO. ILLINOIS FED. AID PROJECT				

# WITNESS MARKER FOR PERMANENT SURVEY MARKERS, TYPE II

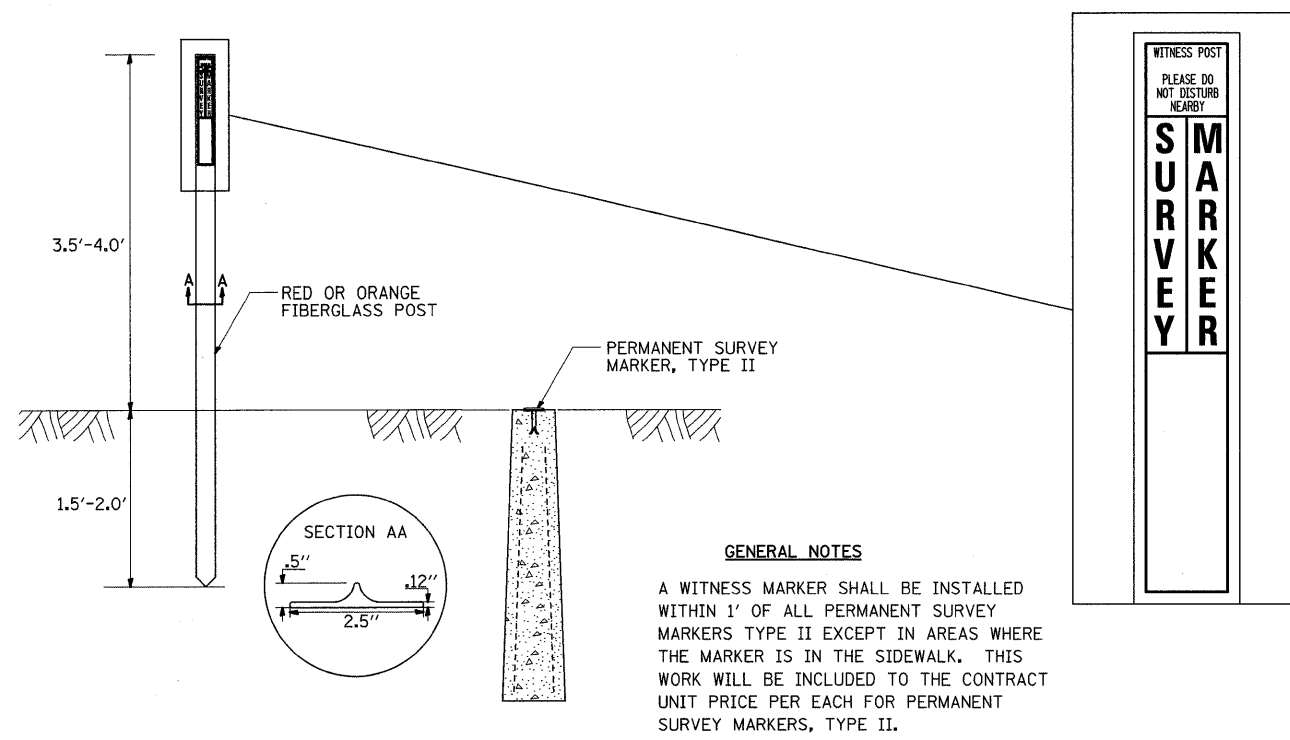

**GENERAL NOTES**  
 A WITNESS MARKER SHALL BE INSTALLED WITHIN 1' OF ALL PERMANENT SURVEY MARKERS TYPE II EXCEPT IN AREAS WHERE THE MARKER IS IN THE SIDEWALK. THIS WORK WILL BE INCLUDED TO THE CONTRACT UNIT PRICE PER EACH FOR PERMANENT SURVEY MARKERS, TYPE II.

# PERMANENT SURVEY MARKERS, TYPE II

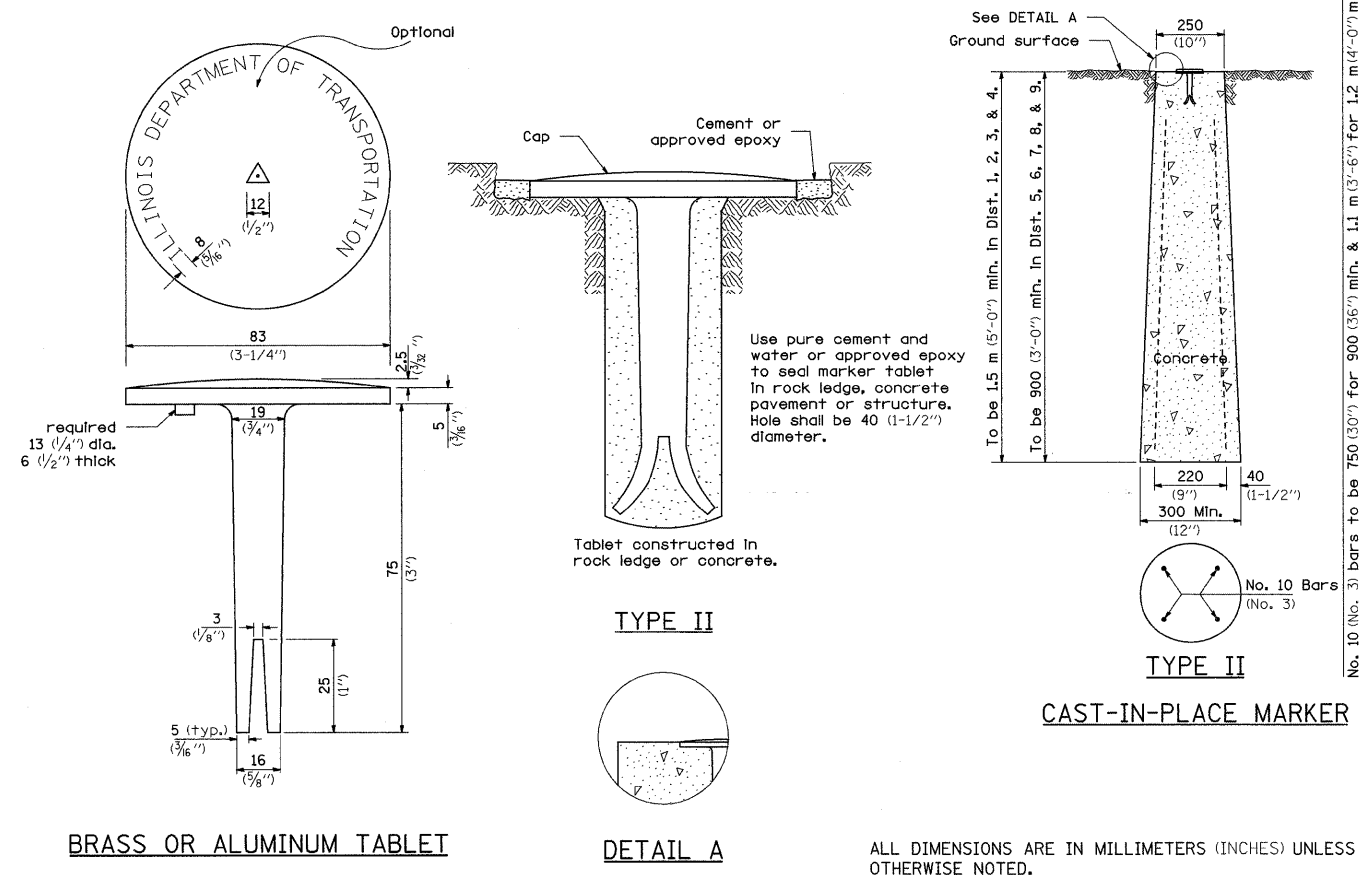

ALL DIMENSIONS ARE IN MILLIMETERS (INCHES) UNLESS OTHERWISE NOTED.

REVISED - 10-21-08

# PRECAST REINFORCED CONCRETE ARCH DIAMETER FLARED END SECTION

SIZE	WALL	SPAN	RISE	L	B	C	E	A	SLOPE	R-1	R-2	R-3	R-4	R-5
450 (18)	64 (2 1/2)	559 (22)	343 (13 1/2)	1829 (72)	686 (27)	1143 (45)	914 (36)	178 (7)	1:2.16	699 (27 1/2)	349 (13 3/4)	133 (5 1/4)	51 (2)	305 (12)
600 (24)	76 (3)	724 (28 1/2)	457 (18)	1829 (72)	991 (39)	838 (33)	1219 (48)	203 (8)	1:2.29	1033 (40 1/8)	370 (14 5/8)	117 (4 5/8)	76 (3)	356 (14)
750 (30)	89 (3 1/2)	921 (36 1/4)	572 (22 1/2)	1829 (72)	1219 (48)	610 (24)	1524 (60)	254 (10)	1:2.34	1295 (51)	476 (18 3/4)	156 (6 1/8)	76 (3)	381 (15)
900 (36)	102 (4)	1111 (43 3/4)	676 (26 5/8)	2438 (96)	1524 (60)	914 (36)	1828 (72)	270 (10 5/8)	1:2.4	1575 (62)	572 (22 1/2)	165 (6 1/2)	152 (6)	508 (20)
1050 (42)	114 (4 1/2)	1308 (51 1/8)	795 (31 1/8)	2438 (96)	1524 (60)	914 (36)	1981 (78)	402 (15 3/8)	1:2.35	1854 (73)	667 (26 1/4)	197 (7 3/4)	152 (6)	559 (22)
1200 (48)	127 (5)	1485 (58 1/2)	914 (36)	2438 (96)	1524 (60)	914 (36)	2134 (84)	533 (21)	1:2.31	2134 (84)	762 (30)	225 (8 7/8)	152 (6)	559 (22)
1350 (54)	140 (5 1/2)	1651 (65)	1016 (40)	2438 (96)	1524 (60)	914 (36)	2286 (90)	648 (25 1/2)	1:2.26	2350 (92 1/2)	848 (33 3/8)	254 (10)	152 (6)	610 (24)
1500 (60)	152 (6)	1854 (73)	1143 (45)	2438 (96)	1905 (75)	533 (21)	2438 (96)	660 (26)	1:2.34	2667 (105)	953 (37 1/2)	281 (11 1/8)	152 (6)	533 (21)
1800 (72)	178 (7)	2235 (88)	1371 (54)	2540 (100)	1981 (78)	559 (22)	3048 (120)	889 (35)	1:2.29	3200 (126)	1143 (45)	338 (13 3/8)	152 (6)	610 (24)

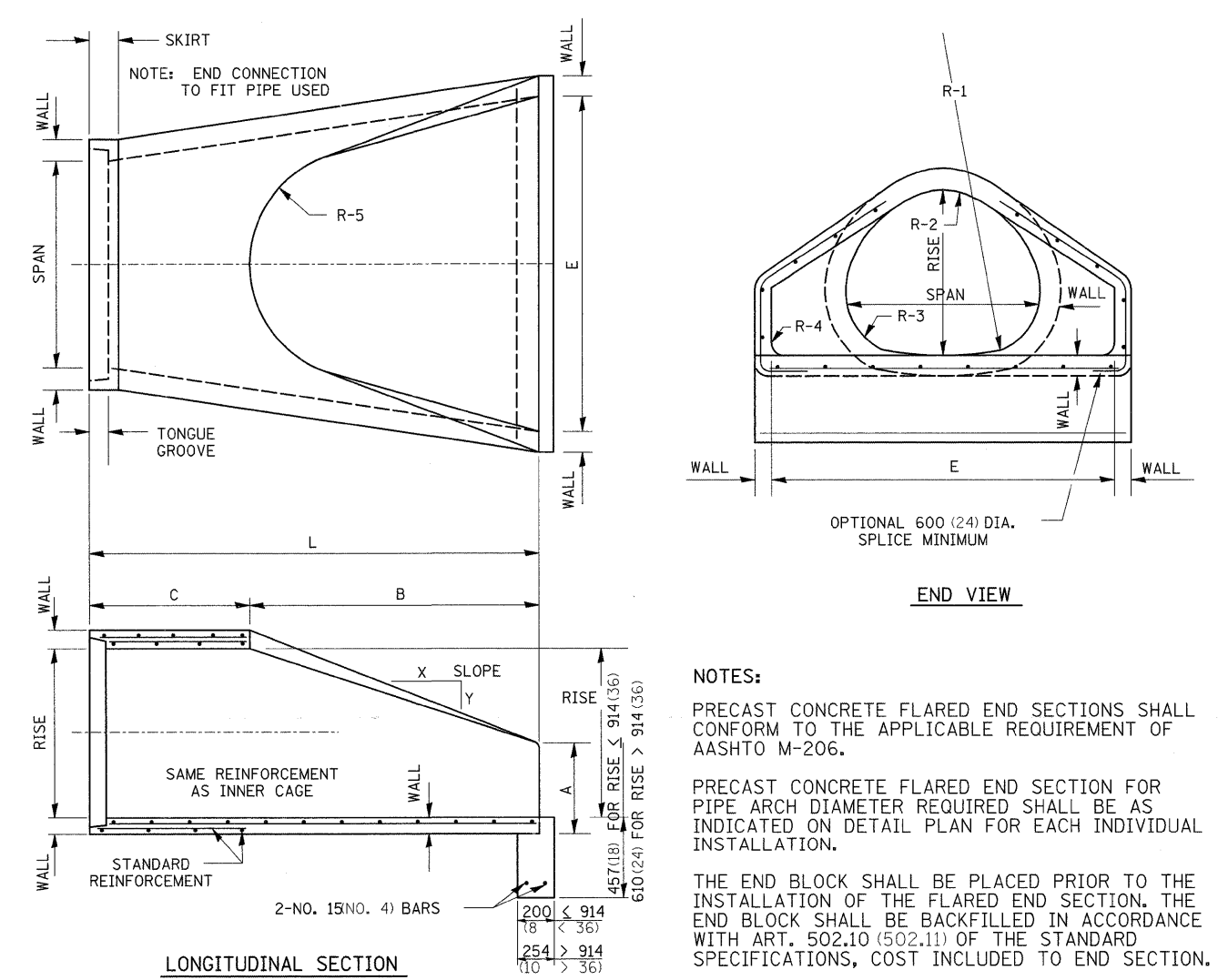

**NOTES:**  
 PRECAST CONCRETE FLARED END SECTIONS SHALL CONFORM TO THE APPLICABLE REQUIREMENT OF AASHTO M-206.  
 PRECAST CONCRETE FLARED END SECTION FOR PIPE ARCH DIAMETER REQUIRED SHALL BE AS INDICATED ON DETAIL PLAN FOR EACH INDIVIDUAL INSTALLATION.  
 THE END BLOCK SHALL BE PLACED PRIOR TO THE INSTALLATION OF THE FLARED END SECTION. THE END BLOCK SHALL BE BACKFILLED IN ACCORDANCE WITH ART. 502.10 (502.11) OF THE STANDARD SPECIFICATIONS, COST INCLUDED TO END SECTION.  
 ALL DIMENSIONS ARE IN MILLIMETERS (INCHES) UNLESS OTHERWISE NOTED.

REVISED - 1-09-08	<b>REGION 2 / DISTRICT 2 STANDARD</b>	F.A.P. RTE. 742	SECTION 37R-4	COUNTY OGLE	TOTAL SHEETS 867	SHEET NO. 472
REVISED -		SCALE: 50.0000' / 1"   SHEET NO. OF SHEETS STA. TO STA.		CONTRACT NO. 64E17		
REVISED -		FED. ROAD DIST. NO. ILLINOIS FED. AID PROJECT				
REVISED -						
REVISED -						



# NAME PLATE FOR CULVERTS

FOR 24"-42" PIPE CULVERTS

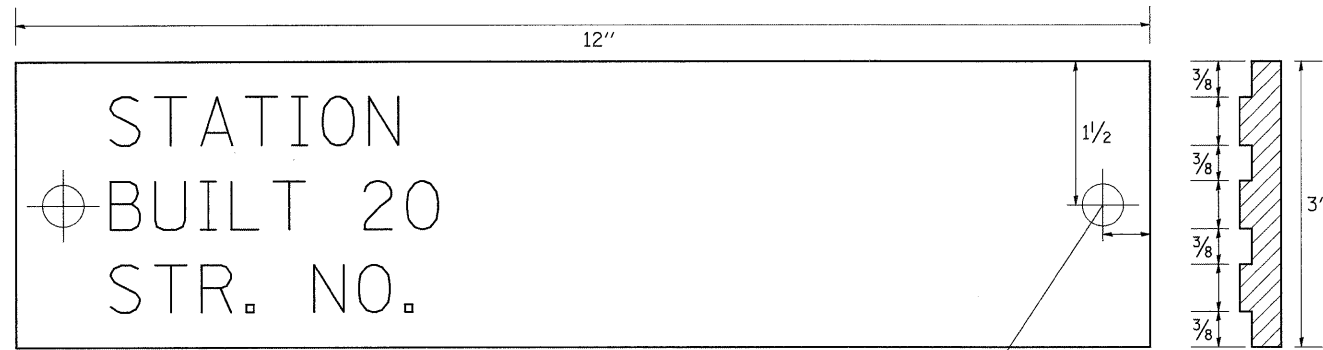

FOR 48"-84" PIPE CULVERTS

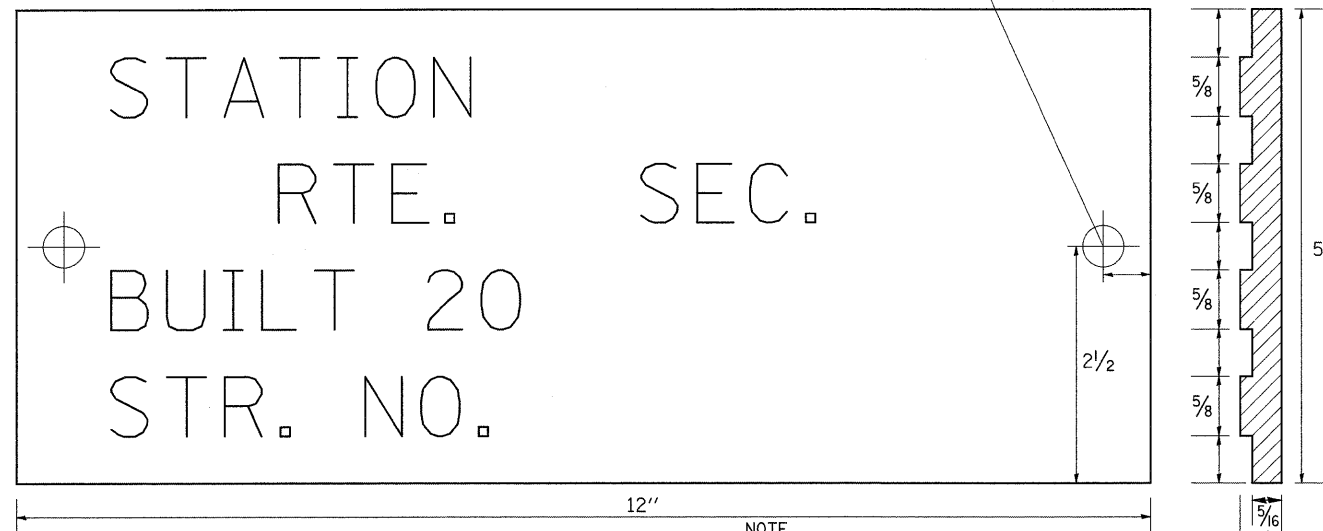

NOTE  
LETTERING RAISED 1/8, SQUARE  
CUT AND NOT TAPERED

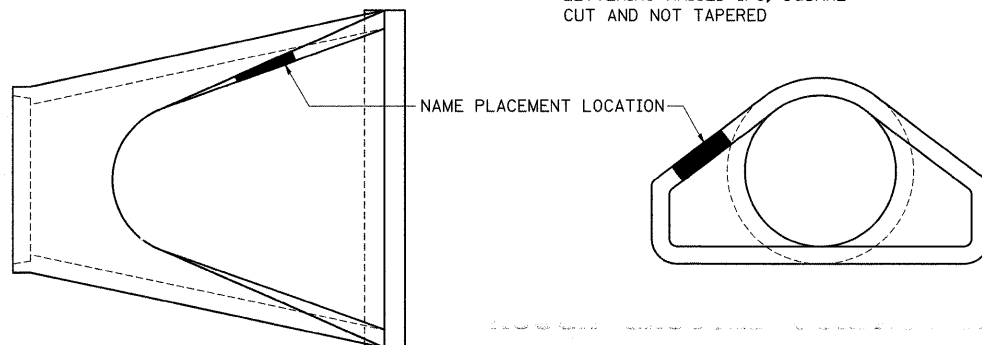

## DESIGNERS NOTE

NAME PLATES SHALL BE FURNISHED & INSTALLED ACCORDING TO SECTION 515 OF THE STANDARD SPECIFICATIONS, EXCEPT 2 BOLTS SHALL BE USE TO FASTEN THE PLATE TO THE END SECTION.

USE STANDARD 515001 FOR BRIDGES AND MULTI-CELL CULVERTS WITH SPANS OF 20' OR MORE MEASURED ALONG THE CENTERLINE AT THE HIGHWAY.

USE THIS DETAIL FOR ALL OTHER PIPE CULVERTS & BOX CULVERTS WITH STRUCTURE NUMBERS. INCLUDE THE INFORMATION TO FILL OUT THE NAME PLATE FOR EACH CULVERT.

IN BOTH CASES INCLUDE A PAY ITEM FOR NAME PLATES.

REVISED - 5-27-09

STATION	STRUCTURE NO.
740+79	071-1163
784+00	071-1206
792+26	071-1207
824+30	071-1211
860+66	071-1212
899+50	071-1214
942+31	071-1215
986+88	071-1217
995+90	071-1209
1010+58	071-1218

# MECHANICAL JOINTS FOR CONCRETE PIPE AND BOX CULVERTS

THE CULVERT TIES SHALL BE INCLUDED IN THE COST OF THE CONCRETE PIPE CULVERTS OR THE PRECAST CONCRETE BOX CULVERT. THE MECHANICAL TIES SHALL BE ON THE OUTSIDE OF THE CULVERT. THE NUTS AND WASHERS SHALL BE PLACED ON THE INSIDE OF OF THE CULVERT AND COVERED WITH MASTIC JOINT SEALER CONFORMING TO ARTICLES 1055 OR 1056 IN THE STANDARD SPECIFICATIONS FOR ROAD AND BRIDGE CONSTRUCTION.

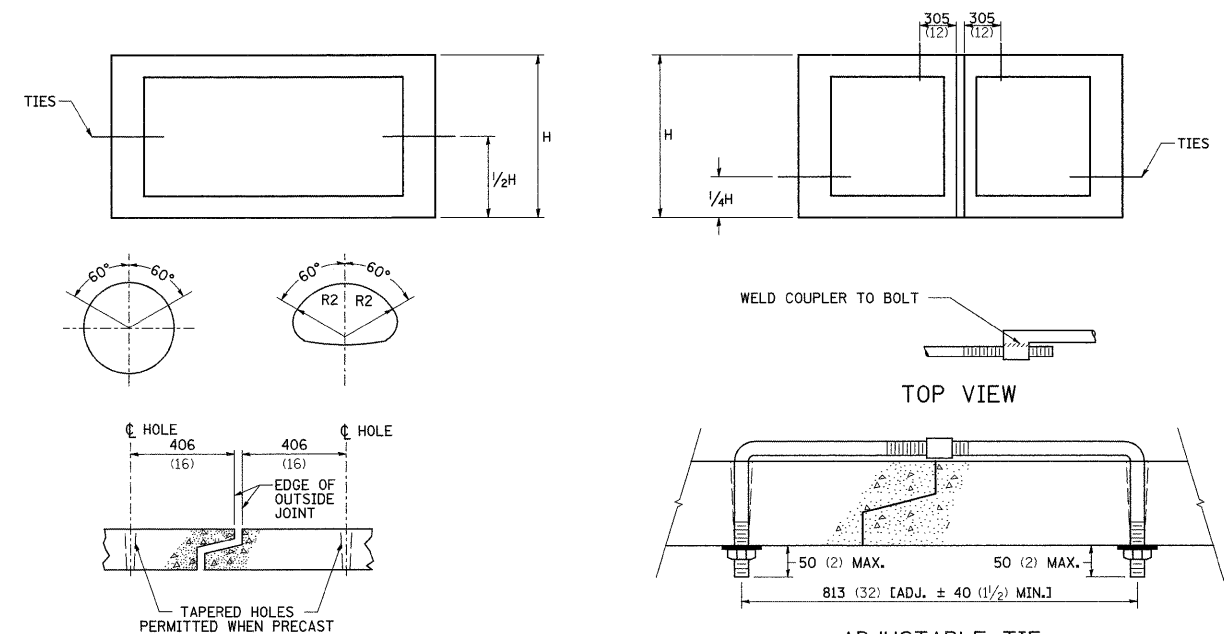

BOX CULVERT METERS (FEET)	PIPE SIZE MILLIMETERS (INCHES)	THREAD DIAMETER
	300 (12)	16 (5/8)
	380 (15)	19 (3/4)
	450 (18)	19 (3/4)
	530 (21)	25 (1)
	600 (24)	25 (1)
	680 (27)	25 (1)
	760 (30)	25 (1)
0.9x0.6 (3x2)	830 (33)	35 (1 1/4)
0.9x0.9 (3x3)	910 (36)	35 (1 1/4)
1.2x0.6 (4x2)	1060 (42)	35 (1 1/4)
1.2x0.9 (4x3)	1210 (48)	35 (1 1/4)
1.2x1.2 (4x4)	1370 (54)	35 (1 1/4)
1.5x0.9 (5x3)	1520 (60)	35 (1 1/4)
1.5x1.2 (5x4)	1670 (66)	35 (1 1/4)
1.5x1.5 (5x5)	1820 (72)	35 (1 1/4)
1.8x * (6x *)	1980 (78)	35 (1 1/4)
2.1x * (7x *)	2130 (84)	35 (1 1/4)
2.4x * (8x *)	2280 (90)	35 (1 1/4)
2.7x * (9x *)	2430 (96)	35 (1 1/4)
3.0x * (10x *)	2590 (102)	35 (1 1/4)
	2740 (108)	35 (1 1/4)
	3040 (120)	35 (1 1/4)
	3350 (132)	35 (1 1/4)
3.4x * (11x *)	3500 (138)	35 (1 1/4)
AND GREATER	AND GREATER	35 (1 1/4)

## NOTES:

- HOLES SHALL BE CAST-IN OR DRILLED 400 (16) FROM OUTSIDE EDGE OF JOINT.
- NUTS AND WASHERS ARE NOT REQUIRED ON INSIDE OF 675 (27) DIAM. PIPE OR LESS.
- TIES ARE NOT REQUIRED FOR BELL PIPE 600 (24) AND SMALLER. ON OTHER SIZES TIE MAY BE INSERTED FROM INSIDE.
- CUT THREADS MAY BE USED IF WASHER AND NUT ARE USED.
- PIPE SIZE LISTED IS INSIDE DIAM. OF ROUND PIPE OR EQUIVALENT DIAM. OF PIPE ARCH OR ELLIPTICAL.
- GALVANIZING OF TIES IS REQUIRED.
- ALL DIMENSIONS ARE IN MILLIMETERS (INCHES) UNLESS OTHERWISE NOTED.

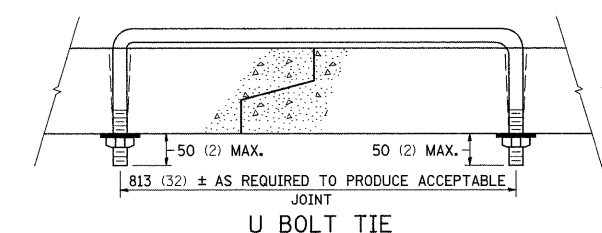
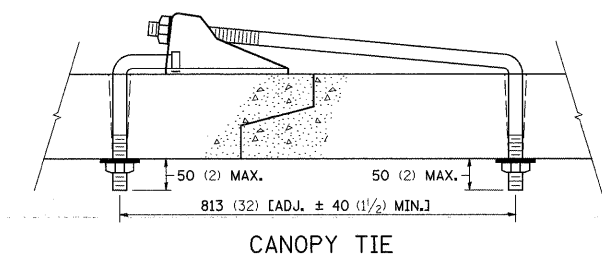
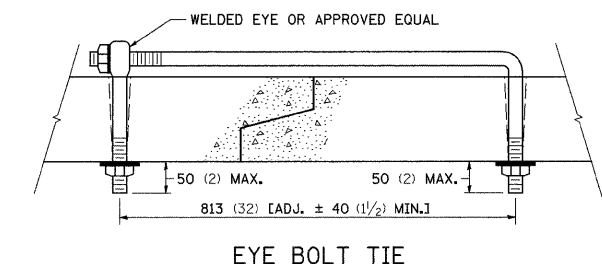
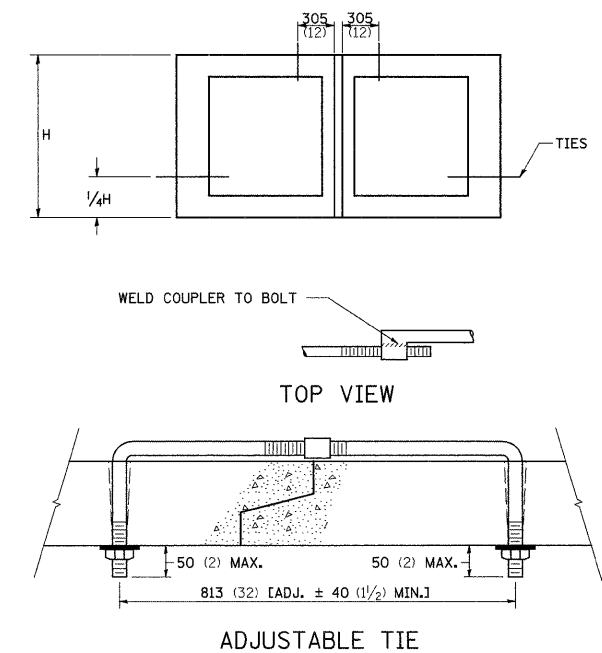

REVISED -	2-1-00	REGION 2 / DISTRICT 2 STANDARD	F.A.P. RTE.	SECTION	COUNTY	TOTAL SHEETS	SHEET NO.
REVISED -			742	37R-4	OGLE	867	473
REVISED -							CONTRACT NO. 64E17
REVISED -		SCALE: 50.0000' / IN. SHEET NO. OF SHEETS STA. TO STA.	FED. ROAD DIST. NO.	ILLINOIS	FED. AID PROJECT		

# ROUGH GROOVED SURFACE SIGN

ILLINOIS STANDARD W8-I107

SIGN PANEL TYPE 1



COLOR: LEGEND AND BORDER - BLACK NON-REFLECTIVE  
BACKGROUND - ORANGE REFLECTORIZED

SIGN SIZE	DIMENSIONS							
	A	B	C	D	E	F	G	H
1200x1200 (48x48)	1200 (48.0)	600 (24.1)	75 (3.0)	850 (34.0)	825 (33.0)	150 (6.0)	325 (13.0)	88 (3.5)

SIGN SIZE	SERIES LINES			MARGIN	BORDER	BLANK STD.
	1	2	3			
1200x1200 (48x48)	7C	7C	7C	20 (0.8)	30 (1.2)	B4-48D

ALL DIMENSIONS IN INCHES.

REVISED - 1-09-08

## GENERAL NOTES

SIGN PANELS AND FACE MATERIALS SHALL BE ACCORDING TO SECTION 720 OF THE STANDARD SPECIFICATIONS

METAL POSTS SHALL BE IN ACCORDANCE WITH STD. 720011.

ALL MOUNTING HARDWARE SHALL BE ALUMINUM, STAINLESS STEEL, ZINC OR CADMIUM PLATED STEEL AND SHALL BE INCLUDED TO THE COST OF THE INSTALLATION.

ALL DIMENSIONS ARE IN MILLIMETERS (INCHES) UNLESS OTHERWISE NOTED.

# TWO CENTER CURVE DATA

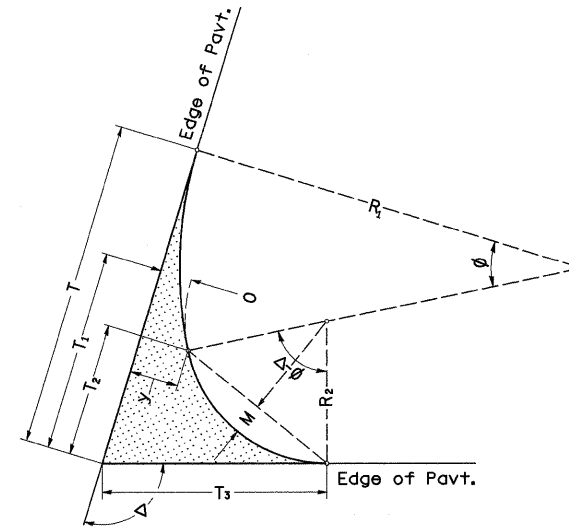

TWO CENTER CURVES

CURVE NO.	1	2	3	4
R1	320.00	180.00	360.00	420.00
R2	80.00	45.00	60.00	70.00
O	8.00	10.00	8.00	10.00
DELTA	104.85	105.00	75.00	104.62
T	167.55	112.31	112.71	176.28
T1	106.10	61.32	43.90	93.21
T2	85.61	44.33	30.13	76.60
T3	112.25	69.00	54.32	100.94
y	10.67	13.33	9.60	12.00
4y9	4.74	5.93	4.27	5.33
y9	1.19	1.48	1.07	1.33
M	23.44	11.25	8.50	20.89
15M16	21.97	10.54	7.97	19.58
3M4	17.58	8.44	6.37	15.67
7M16	10.25	4.92	3.72	9.14
C	113.15	59.52	61.57	99.76

REVISED -	REGION 2 / DISTRICT 2 STANDARD	F.A.P. RTE.	SECTION	COUNTY	TOTAL SHEETS	SHEET NO.
REVISED -		742	37R-4	OGLE	867	474
REVISED -		SCALE: 50.0000' / 1" SHEET NO. OF SHEETS STA. TO STA.		CONTRACT NO. 64E17		
REVISED -		FED. ROAD DIST. NO. [ILLINOIS] FED. AID PROJECT				
REVISED -		PLOT DATE = Tue Mar 30 09:22:38 2010				

# TYPICAL AGGREGATE BASE SIDEROAD

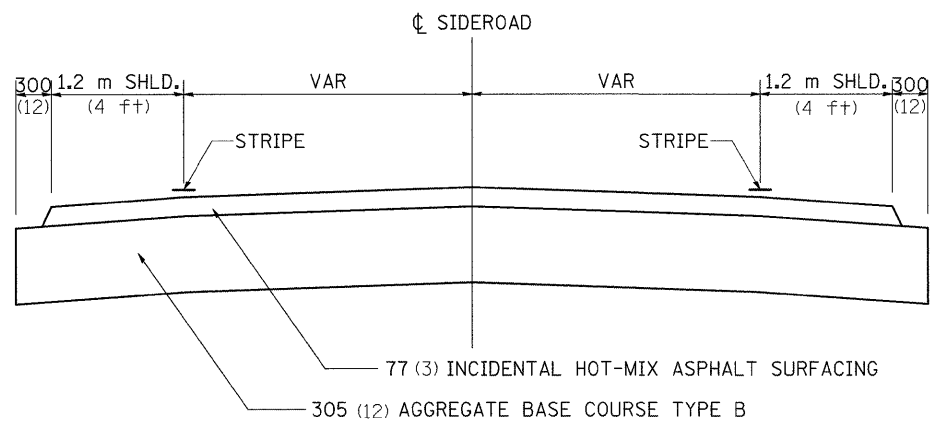
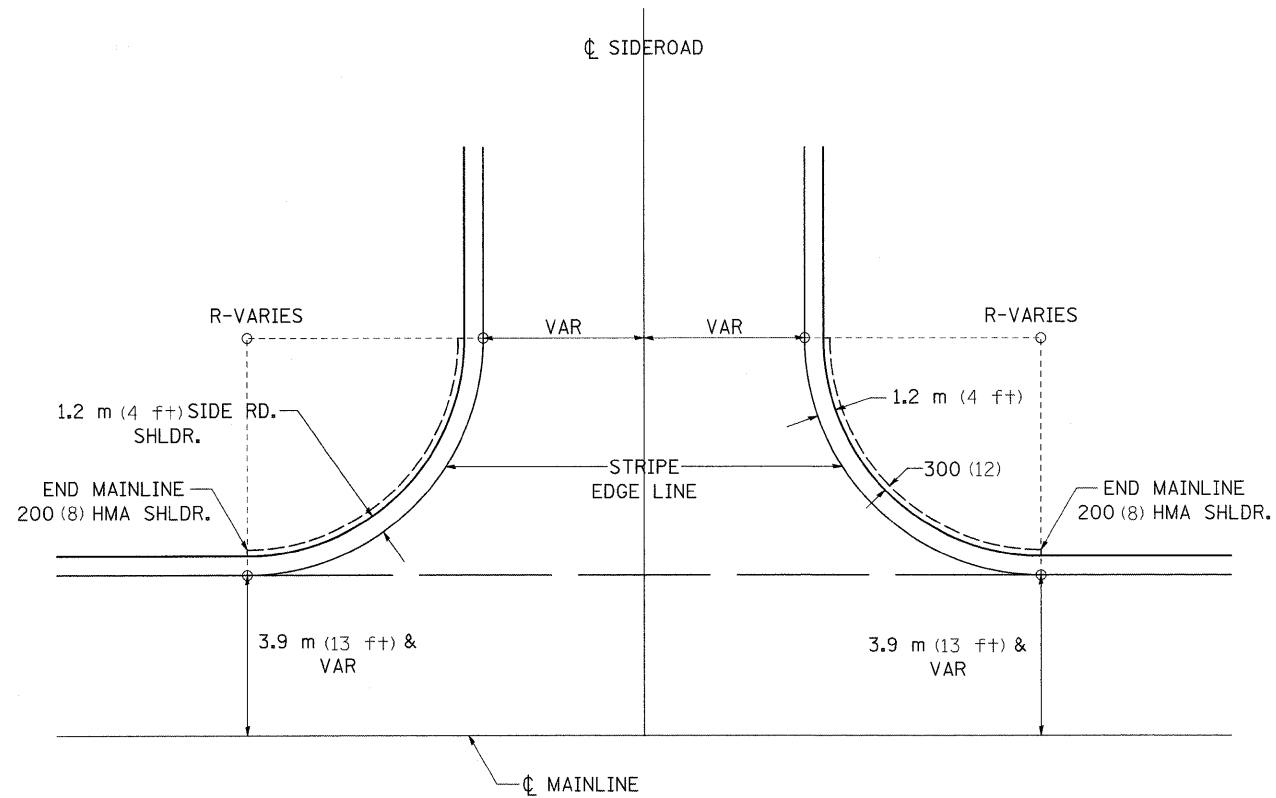

ALL DIMENSIONS ARE IN MILLIMETERS (INCHES) UNLESS OTHERWISE NOTED.

REVISED - 1-10-08

REVISED -	REGION 2 / DISTRICT 2 STANDARD				F.A.P. RTE.	SECTION	COUNTY	TOTAL SHEETS	SHEET NO.
REVISED -					742	37R-4	OGLE	867	475
REVISED -	SCALE: 50.0000' / 1" SHEET NO. OF SHEETS STA. TO STA.	FED. ROAD DIST. NO.		ILLINOIS FED. AID PROJECT		CONTRACT NO. 64E17			

# ENTRANCES, SIDE ROADS, AND MAILBOX RETURNS WITH NO HOT-MIX ASPHALT SHOULDERS

7.2m (24') FIELD ENTRANCE		
	APRON	PER M (LIN FT) OF ENTR
AGG BASE CSE T-B M (TON)	38.5 (44.5)	3.5 (1.2)

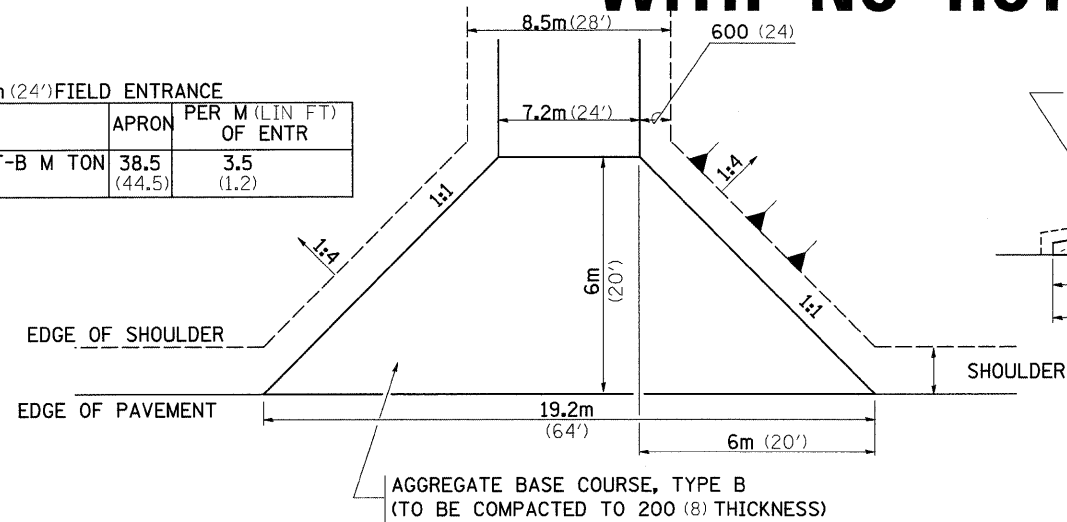

**FIELD ENTRANCE**

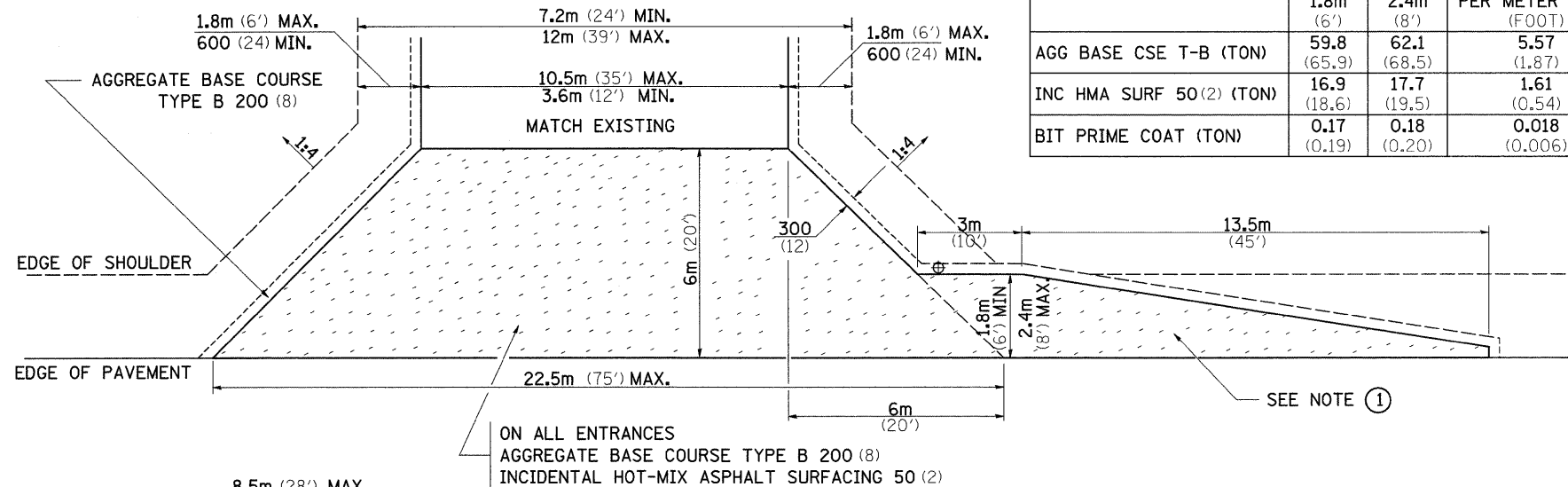

10.5m (35') COMMERCIAL ENTRANCE			
	1.8m (6')	2.4m (8')	PER METER ENTR (FOOT)
AGG BASE CSE T-B (TON)	59.8 (65.9)	62.1 (68.5)	5.57 (1.87)
INC HMA SURF 50 (2) (TON)	16.9 (18.6)	17.7 (19.5)	1.61 (0.54)
BIT PRIME COAT (TON)	0.17 (0.19)	0.18 (0.20)	0.018 (0.006)

**COMMERCIAL ENTRANCE**

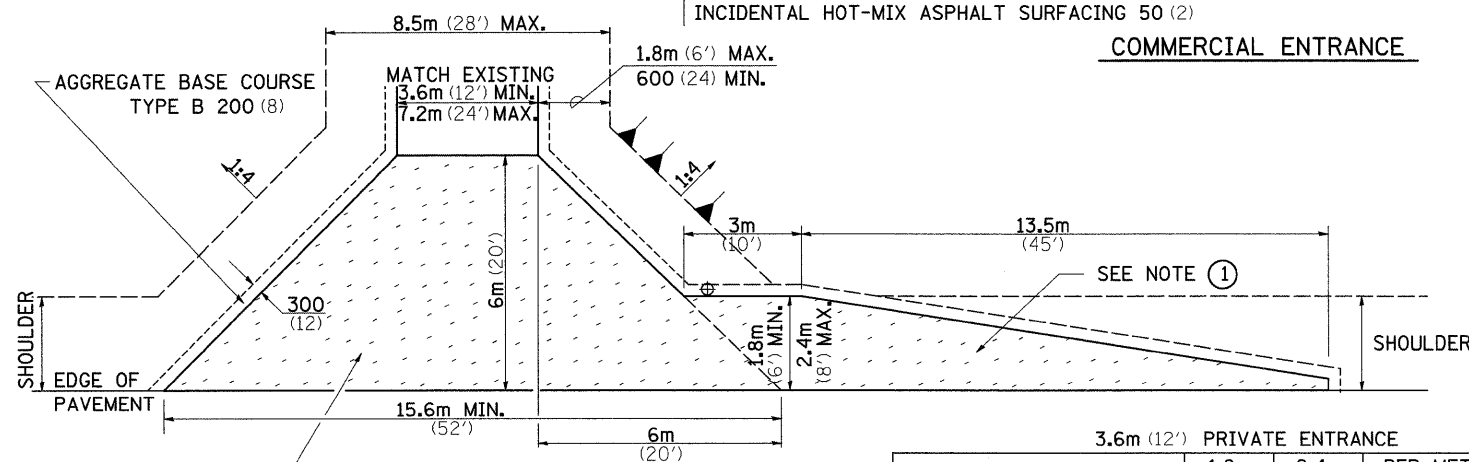

**PRIVATE ENTRANCE**

3.6m (12') PRIVATE ENTRANCE			
	1.8m (6')	2.4m (8')	PER METER ENTR (FOOT)
AGG BASE CSE T-B (TON)	39.7 (43.8)	42.0 (46.3)	2.11 (0.71)
INC HMA SURF 50 (2) (TON)	10.7 (11.8)	11.5 (12.7)	0.57 (0.19)
BIT PRIME COAT (TON)	0.11 (0.12)	0.18 (0.13)	0.006 (0.002)

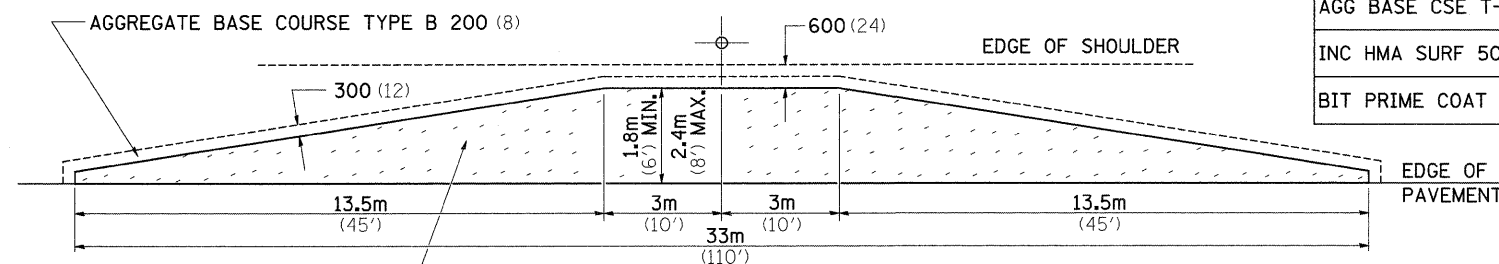

**MAILBOX TURNOUT**

ON ALL ENTRANCES  
AGGREGATE BASE COURSE TYPE B 200 (8)  
INCIDENTAL HOT-MIX ASPHALT SURFACING 50 (2)

**NOTE**

- TURNOUTS ARE TO BE CONSTRUCTED ON THE APPROACH SIDE OF ALL PE & CE REGARDLESS IF A MAILBOX IS PRESENT.
- ALL PE & CE ARE TO BE SURFACED TO RIGHT OF WAY LINE. AREA BEHIND RIGHT OF WAY SHALL MATCH EXISTING SURFACE.
- FE ARE TO BE AGGREGATE TO RIGHT OF WAY OR TOUCH DOWN, WHICH EVER IS GREATEST.
- QUANTITIES ARE CALCULATED WITH 1' BITUMINOUS SHOULDER IN PLACE. AGGREGATE QUANTITIES SHOWN ARE FOR NEW CONSTRUCTION.
- EXCAVATION REQUIRED FOR PLACEMENT OF AGGREGATE BASE COURSE SHALL BE CONSIDERED INCLUDED TO THE AGGREGATE BASE COURSE.
- ALL DIMENSIONS ARE IN MILLIMETERS (INCHES) UNLESS OTHERWISE NOTED.

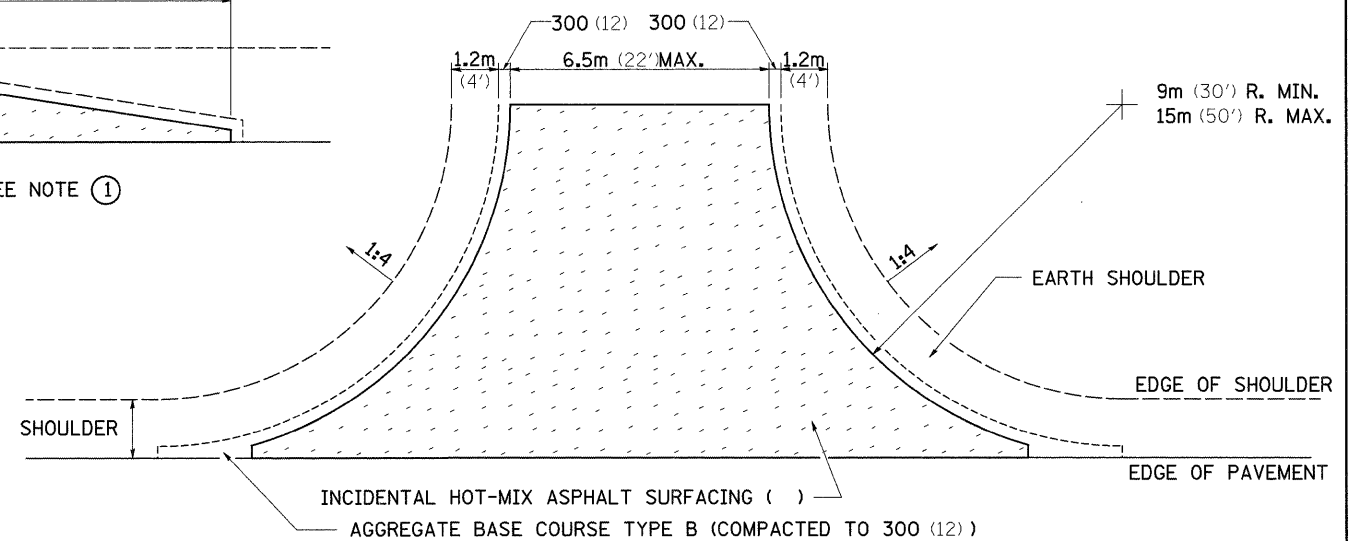

**SIDE ROAD RETURN**

	9m RADIUS (30')			12m RADIUS (40')			15m RADIUS (50')		
	5.5m (18')	6m (20')	6.5m (22')	5.5m (18')	6m (20')	6.5m (22')	5.5m (18')	6m (20')	6.5m (22')
AGG BASE CSE T-B (TON)	70.3 (77.5)	74.4 (82.0)	78.6 (86.6)	105.5 (116.3)	111.0 (122.4)	116.6 (128.5)	146.6 (161.6)	153.5 (169.2)	116.6 (128.5)
INC HMA SURF AT 25 (1) (TON)	5.3 (5.8)	5.5 (6.1)	5.9 (6.5)	8.0 (8.8)	8.4 (9.3)	9.0 (9.9)	11.1 (12.2)	11.7 (12.9)	9.0 (9.9)
BIT PRIME COAT (TON)	0.14 (0.15)	0.15 (0.16)	0.15 (0.17)	0.20 (0.22)	0.22 (0.24)	0.23 (0.25)	0.30 (0.33)	0.32 (0.35)	0.32 (0.37)

NOTE: USE 50 (2) INC. HMA SURF. ON EXISTING RETURNS

FILE NAME =	USER NAME = grantpm	DESIGNED -	REVISED - 1-15-08	<b>STATE OF ILLINOIS DEPARTMENT OF TRANSPORTATION</b>	<b>REGION 2 / DISTRICT 2 STANDARD</b>	F.A.P. RTE. 742	SECTION 37R-4	COUNTY OGLE	TOTAL SHEETS 867	SHEET NO. 476
CONTRACT NO. 64E17	SCALE:	SHEET NO. OF SHEETS	STA. TO STA.			FED. ROAD DIST. NO. [ILLINOIS] FED. AID PROJECT				
PLOT SCALE = 50.0000' / IN.	CHECKED -	REVISED -								
PLOT DATE = Tue Mar 30 09:22:40 2010	DATE -	REVISED -								

# SLOPED METAL END SECTIONS WITH GRATE

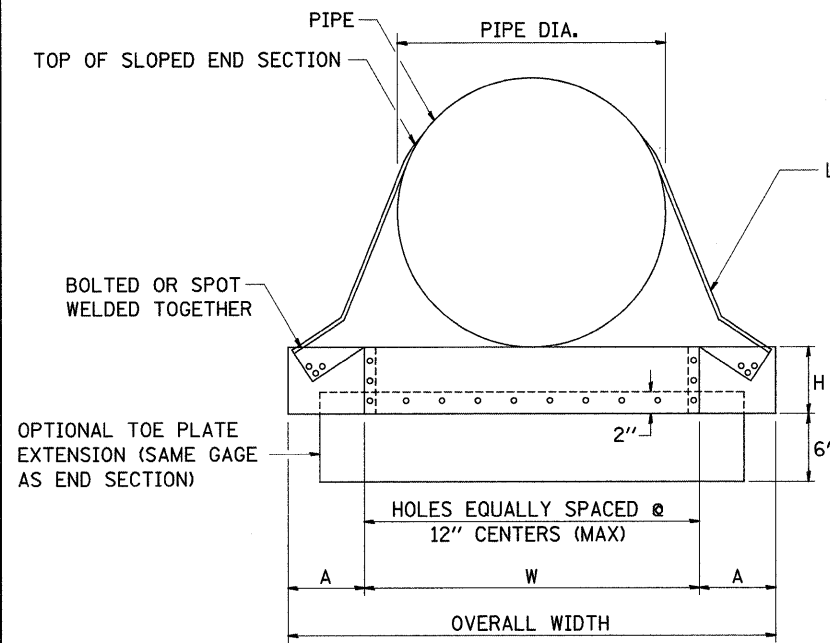

FRONT VIEW ROUND PIPE

REINFORCED EDGE FULL LENGTH OF END SECTION (SEE SECTION A-A)

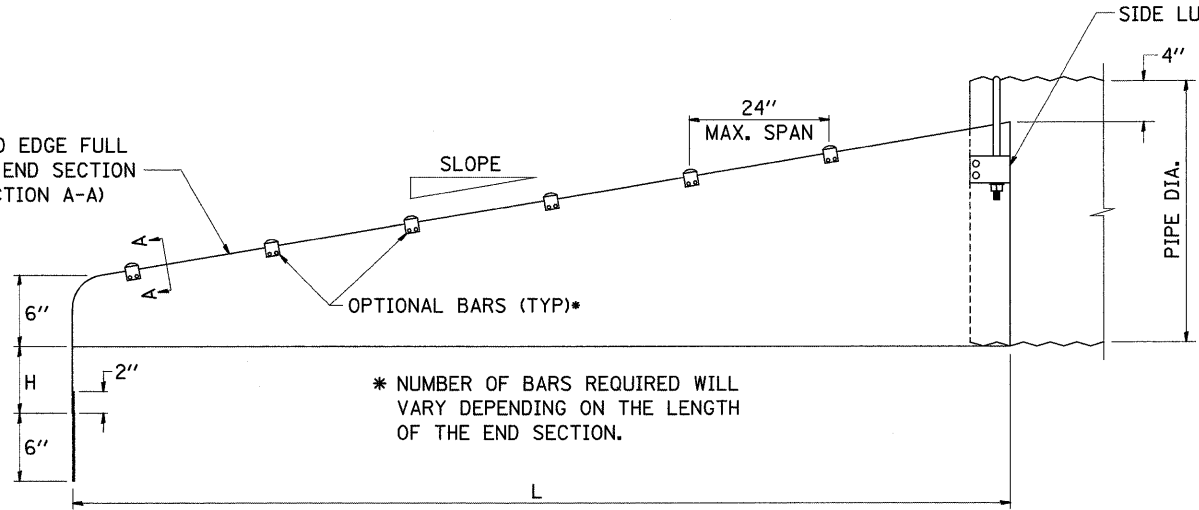

SIDE ELEVATION

\* NUMBER OF BARS REQUIRED WILL VARY DEPENDING ON THE LENGTH OF THE END SECTION.

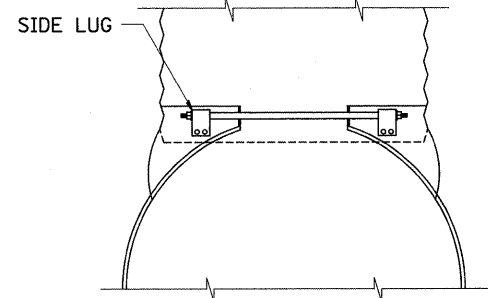

TYPE #2 CONNECTOR DETAILS (SHOWN)

TYPE #1 CONNECTOR DETAILS THRU 24" GALVANIZED STRAP  
TYPE #2 CONNECTOR DETAILS (SHOWN) FOR 30" AND LARGER 21" x 15" AND LARGER 1/2" THREADED ROD W/FLANGED NUT AND SIDE LUG

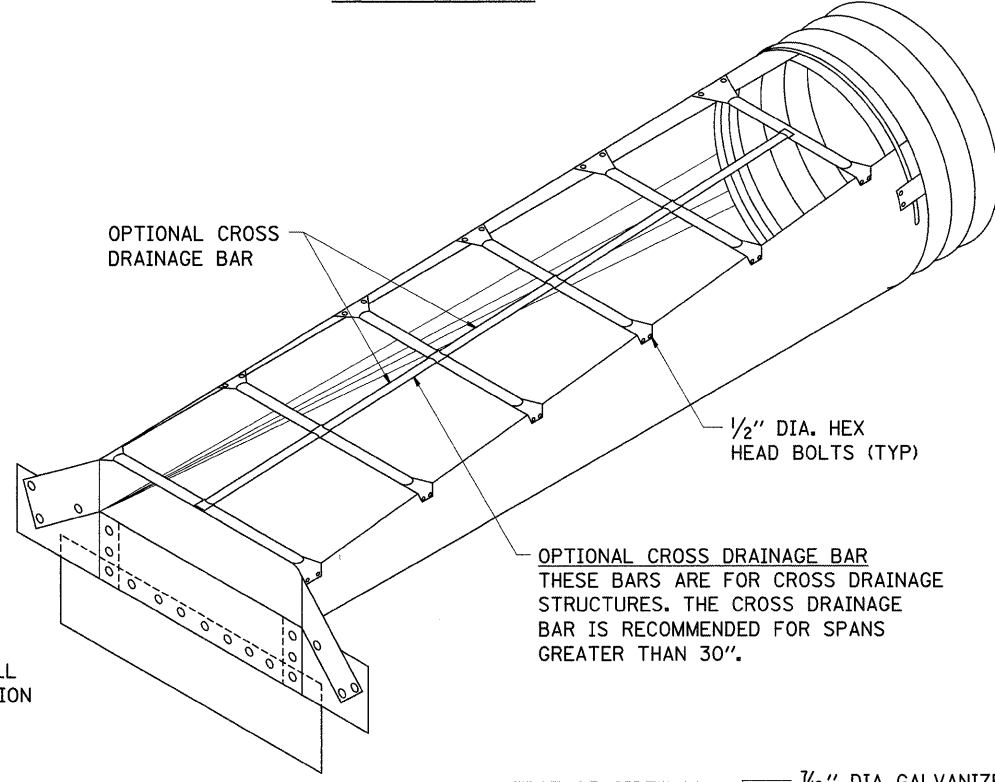

CIRCULAR PIPE ISOMETRIC VIEW

OPTIONAL CROSS DRAINAGE BAR THESE BARS ARE FOR CROSS DRAINAGE STRUCTURES. THE CROSS DRAINAGE BAR IS RECOMMENDED FOR SPANS GREATER THAN 30".

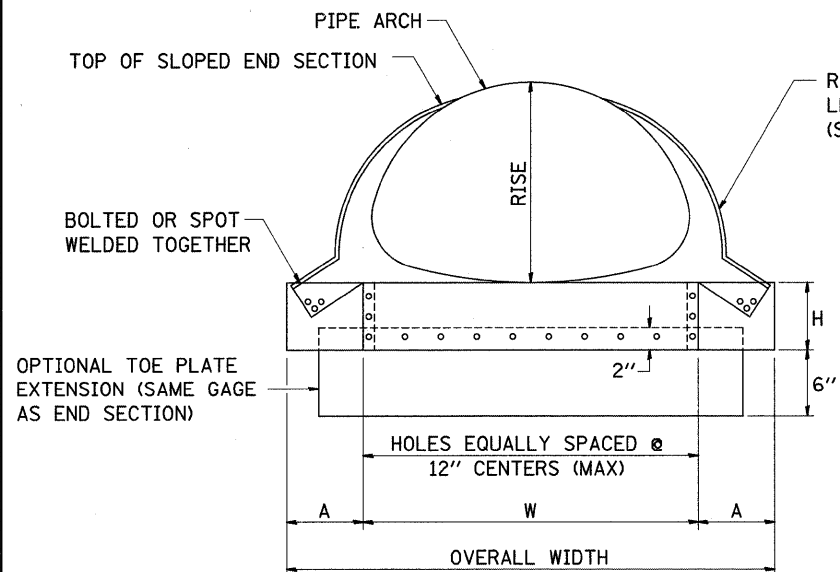

FRONT VIEW PIPE ARCH

REINFORCED EDGE FULL LENGTH OF END SECTION (SEE SECTION A-A)

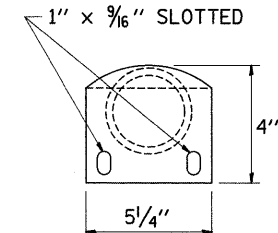

DETAIL OF OPTIONAL BARS

3" GALVANIZED PIPE FLATTEN END, THEN BEND OUTSIDE 4" TO MATCH END SECTION SIDES.

EDGE OF SIDEWALL ROLLED SNUGLY AGAINST STEEL ROD. 1/16" DIA GALVANIZED STEEL ROD OR NO. 4 GALVANIZED REINFORCING BAR.

SECTION A-A

## GENERAL NOTES

- CONNECTORS - ROUND SIZES THRU 24" ATTACH TO PIPE WITH TYPE #1 STRAPS, ALL OTHER SIZES ATTACH WITH TYPE #2 RODS AND LUGS.
- TOE PLATE EXTENSIONS - WHEN REQUIRED, TOE PLATE EXTENSIONS ARE TO BE THE SAME GAGE AS END SECTION. DIMENSIONS SHALL BE OVERALL WIDTH LESS 6 INCHES BY 8 INCHES HIGH.
- OPTIONAL BARS - BARS WHEN SPECIFIED, SHALL BE SCHEDULE 40 GALVANIZED STEEL PIPE.
- TYPICALLY PARALLEL BARS ARE PLACED ON 24" CENTERS.
- TYPICALLY THE CROSS BARS ARE USED ON CROSS DRAIN APPLICATIONS.
- HOLES FOR BAR ATTACHMENTS SHALL BE PROVIDED ON ALL END SECTIONS.
- DIMENSIONS ARE SUBJECT TO MANUFACTURING TOLERANCES.
- THESE END SECTIONS WILL BE PAID FOR AT THE CONTRACT UNIT PRICE PER EACH FOR SLOPED METAL END SECTIONS WITH GRATE OF THE DIAMETER SPECIFIED, WHICH SHALL INCLUDE FURNISHING AND INSTALLING THE END SECTION COMPLETE IN PLACE, INCLUDING THE TOE PLATE, EXCAVATING, BACKFILLING, CONNECTING TO THE PIPE, AND CROSS DRAINAGE BARS.

PIPE DIA. (IN.)	MIN. THICK IN.	GAGE	DIMENSIONS (INCHES)				L DIMENSIONS			
			A	H	W	OVERALL WIDTH	SLOPE	LENGTH (IN.)	SLOPE	LENGTH (IN.)
15	.064	16	8	6	21	37	6:1	30	4:1	20
18	.064	16	8	6	24	40	6:1	48	4:1	32
21	.064	16	8	6	27	43	6:1	66	4:1	44
24	.064	16	8	6	30	46	6:1	84	4:1	56
30	.109	12	12	9	36	60	6:1	120	4:1	80
36	.109	12	12	9	42	66	4:1	104	6:1	156
42	.109	12	16	12	48	80	4:1	128	6:1	192
48	.109	12	16	12	54	86	4:1	152	6:1	228
54	.109	12	16	12	60	92	4:1	176	6:1	264
60	.109	12	16	12	66	98	4:1	200	6:1	300

EQUIV. DIA. (IN.)	(INCHES)		MIN. THICK IN.	GAGE	DIMENSIONS (INCHES)			L DIMENSIONS				
	SPAN	RISE			A	H	W	OVERALL WIDTH	SLOPE	LENGTH (IN.)	SLOPE	LENGTH (IN.)
18	21	15	.064	16	8	6	27	43	6:1	30	4:1	20
21	24	18	.064	16	8	6	30	46	6:1	48	4:1	32
24	28	20	.064	16	8	6	34	50	6:1	60	4:1	40
30	36	24	.079	14	12	9	41	65	6:1	84	4:1	56
36	42	29	.109	12	12	9	48	72	6:1	114	4:1	76
42	49	33	.109	12	16	12	55	87	4:1	92	6:1	138
48	57	38	.109	12	16	12	63	95	4:1	112	6:1	168
54	64	43	.109	12	16	12	70	102	4:1	132	6:1	198
60	71	47	.109	12	16	12	77	109	4:1	148	6:1	222
72	83	57	.109	12	16	12	89	121	4:1	188	6:1	282

FILE NAME =	USER NAME = grantpm	DESIGNED -	REVISED - 5-8-96	<b>STATE OF ILLINOIS DEPARTMENT OF TRANSPORTATION</b>	<b>REGION 2 / DISTRICT 2 STANDARD</b>			F.A.P. RTE. 742	SECTION 37R-4	COUNTY OGLE	TOTAL SHEETS 867	SHEET NO. 477
ct:\pw_work\VPWIDOT\GRANTPM\dms31213\406528spl.dgn	DRAWN -	REVISIONS -	CONTRACT NO. 64E17									
PLOT SCALE = 50.0000' / IN.	CHECKED -	SCALE:	SHEET NO. OF SHEETS STA. TO STA.									
PLOT DATE = Tue Mar 30 09:22:41 2010	DATE -	FED. ROAD DIST. NO. ILLINOIS FED. AID PROJECT										

# TRAFFIC CONTROL FOR ROAD CLOSURE

## CONDITION II

Minor Sideroad Closure

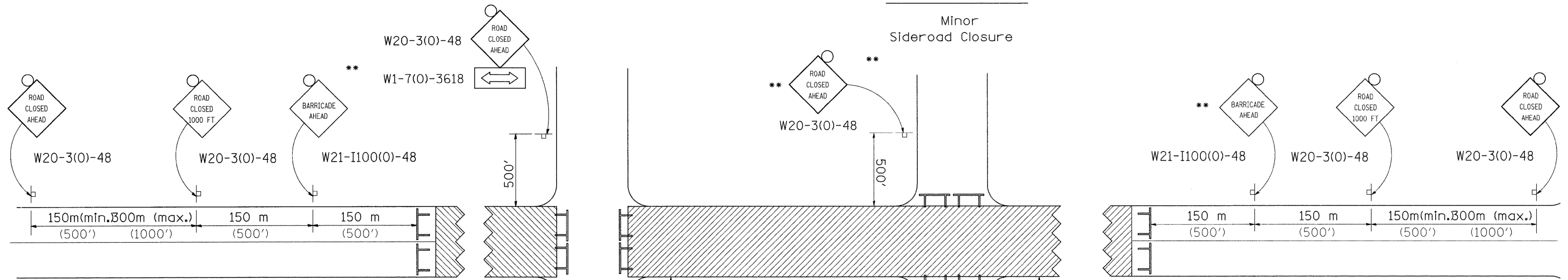

## CONDITION I

Major Sideroad Closure

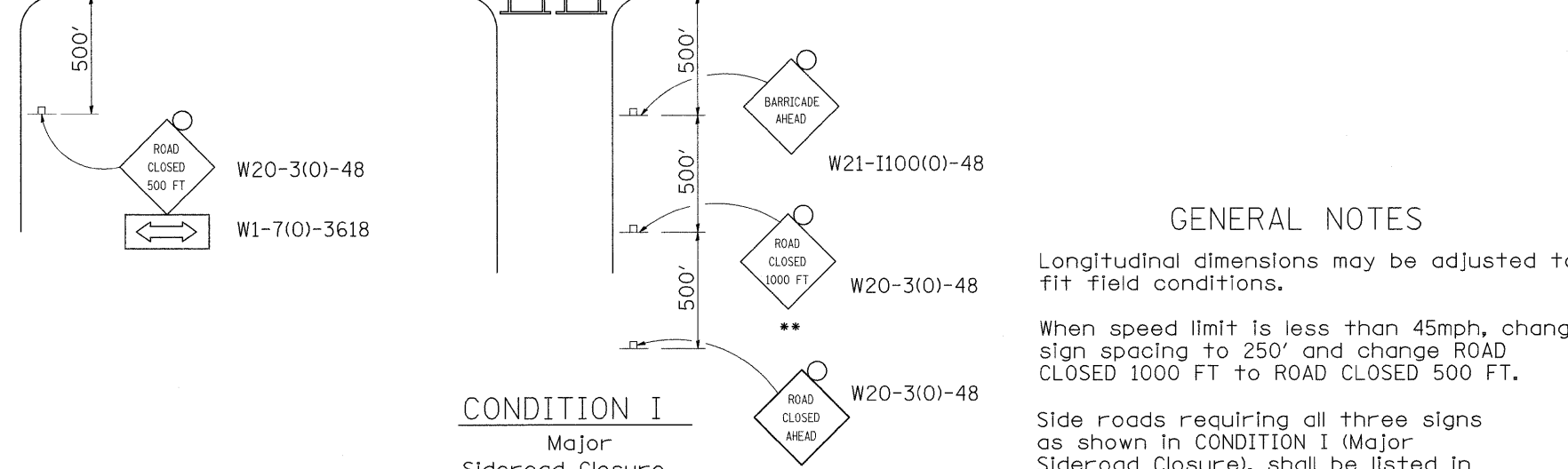

### GENERAL NOTES

Longitudinal dimensions may be adjusted to fit field conditions.

When speed limit is less than 45mph, change sign spacing to 250' and change ROAD CLOSED 1000 FT to ROAD CLOSED 500 FT.

Side roads requiring all three signs as shown in CONDITION I (Major Sideroad Closure), shall be listed in the special provision.

\*\* Where local access is to be maintained, barricades are to be set up as shown in Road Closed to thru traffic. Type III Barricades and R11-2-4830 signs shall be as shown in "Road Closed To All Traffic" detail on Highway Standard 701901.

All dimensions are in millimeters (inches) unless otherwise shown.

### ROAD CLOSED TO THRU TRAFFIC BARRICADE SET UP

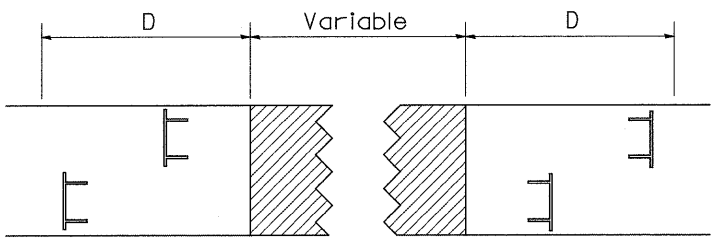

Type III Barricades and R11-4-4830 signs shall be as shown in "Road Closed To All Thru Traffic" detail on Highway Standard 701901. If the distance "D" exceeds 600 m (2000') an additional set of barricades and R11-4-4830 shall be placed at each end of the work area.

### SYMBOLS

- Work area
- Type III Barricade with Flashers
- Sign with flashing light

TYPICAL APPLICATION FOR ROAD CLOSURE

FILE NAME =	USER NAME = grantpm	DESIGNED -	REVISED - 1-11-08	<b>STATE OF ILLINOIS DEPARTMENT OF TRANSPORTATION</b>	<b>REGION 2 / DISTRICT 2 STANDARD</b>			F.A.P. RTE.	SECTION	COUNTY	TOTAL SHEETS	SHEET NO.
ct:\pw_work\PIWIDOT\GRANTPM\dms31213\086508apl.dgn	DRAWN -	REVISED -	742					37R-4	OGLE	867	478	
PLOT SCALE = 50.0000' / IN.	CHECKED -	REVISED -	CONTRACT NO. 64E17									
PLOT DATE = Tue Mar 30 09:22:42 2010	DATE -	REVISED -	SCALE:		SHEET NO.	OF SHEETS	STA.	TO STA.	FED. ROAD DIST. NO.	ILLINOIS FED. AID PROJECT		

# TYPICAL PAVEMENT MARKINGS

## TYPICAL PAVEMENT MARKING FOR FLUSH MEDIAN AT LEFT TURN LANE

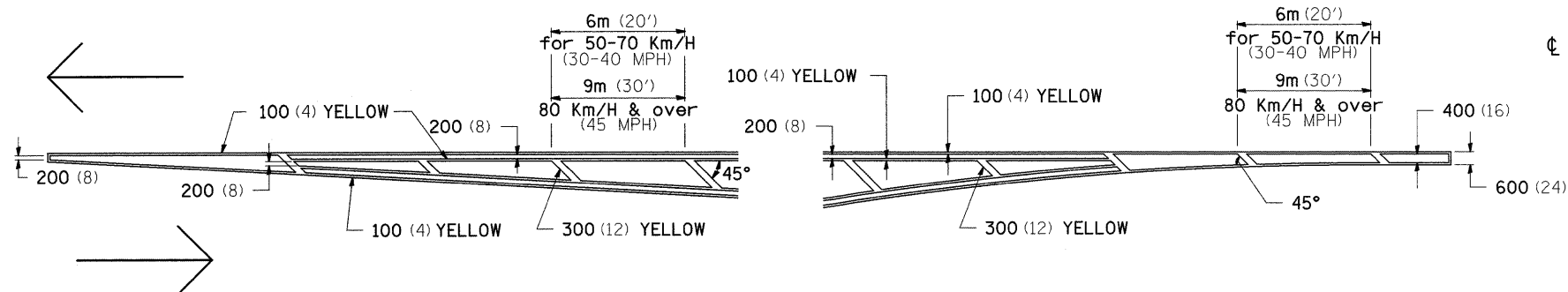

## MEDIAN PAVEMENT MARKING

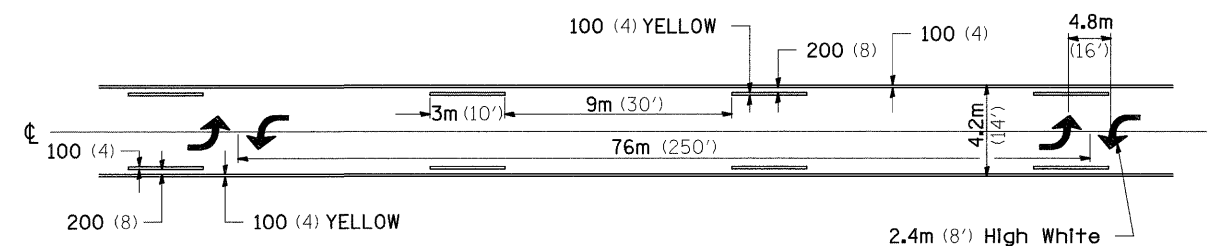

\*\* ALL DIMENSIONS ARE IN MILLIMETERS (INCHES) UNLESS OTHERWISE NOTED.

## TYPICAL ISLAND OFFSET SHOULDER WIDTH

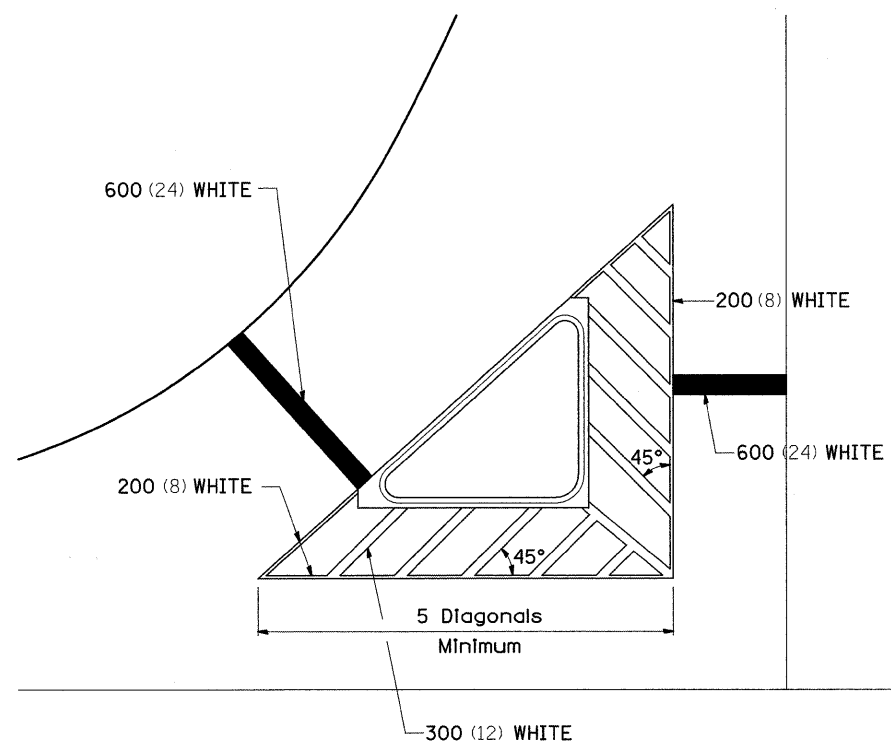

## TYPICAL PARKING SPACING

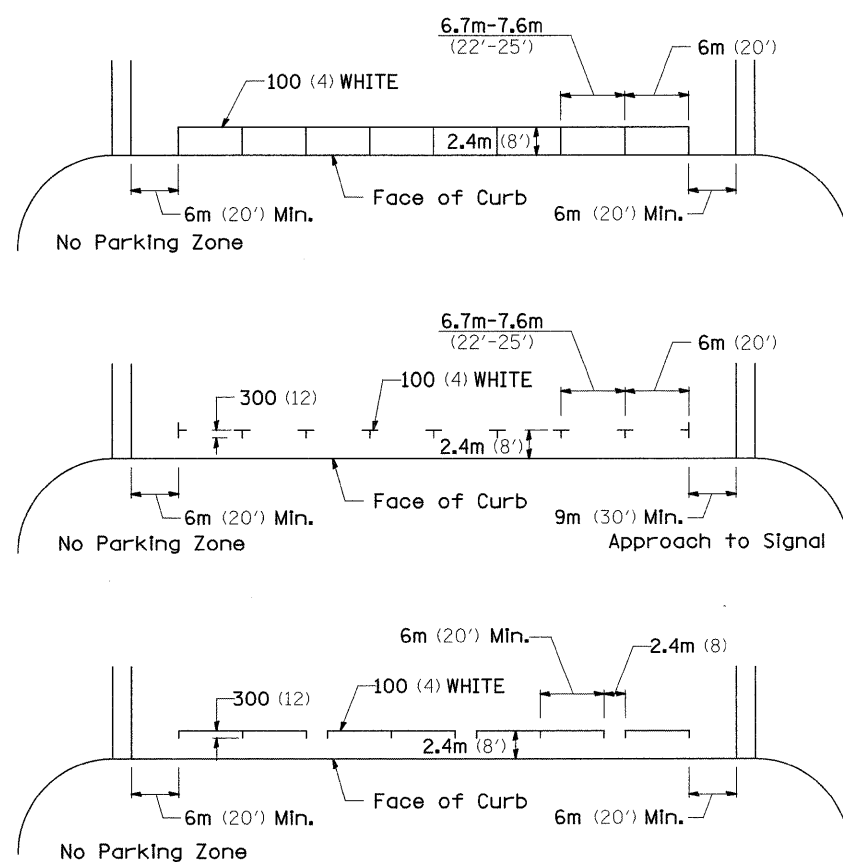

## STANDARD CROSSWALK MARKING

See Schedules for Locations

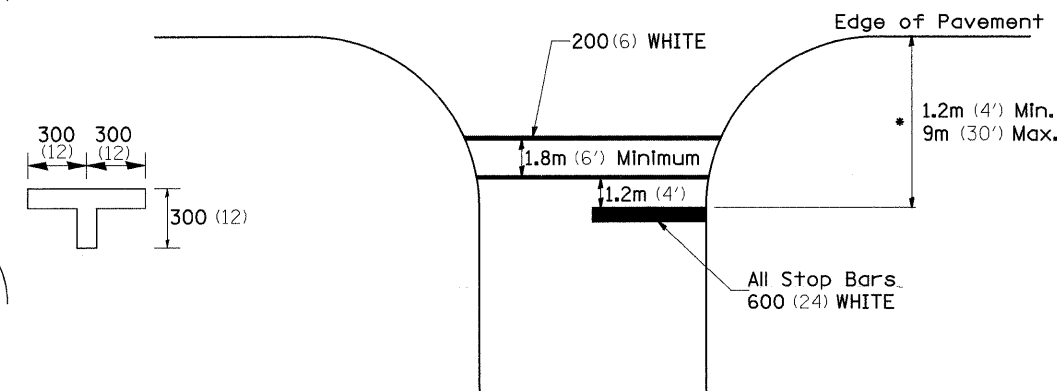

\* Distance to the nearest edge of the intersecting roadway in the absence of a marked crosswalk.

FILE NAME =	USER NAME = grantpm	DESIGNED -	REVISED - 10-21-08	<b>STATE OF ILLINOIS DEPARTMENT OF TRANSPORTATION</b>	<b>REGION 2 / DISTRICT 2 STANDARD</b>	F.A.P. RTE.	SECTION	COUNTY	TOTAL SHEETS	SHEET NO.
of:\pwwork\NPWIDOT\GRANTPM\dms31213\086608apl.dgn	PLOT SCALE = 50.0000' / IN.	DRAWN -	REVISED -			742	37R-4	OGLE	867	479
PLOT DATE = Tue Mar 30 09:22:42 2010	CHECKED -	REVISED -	REVISED -			CONTRACT NO. 64E17				
	DATE -	REVISED -	REVISED -			FED. ROAD DIST. NO. ILLINOIS FED. AID PROJECT				

# TYPICAL PAVEMENT MARKINGS

## ARROW LAYOUT

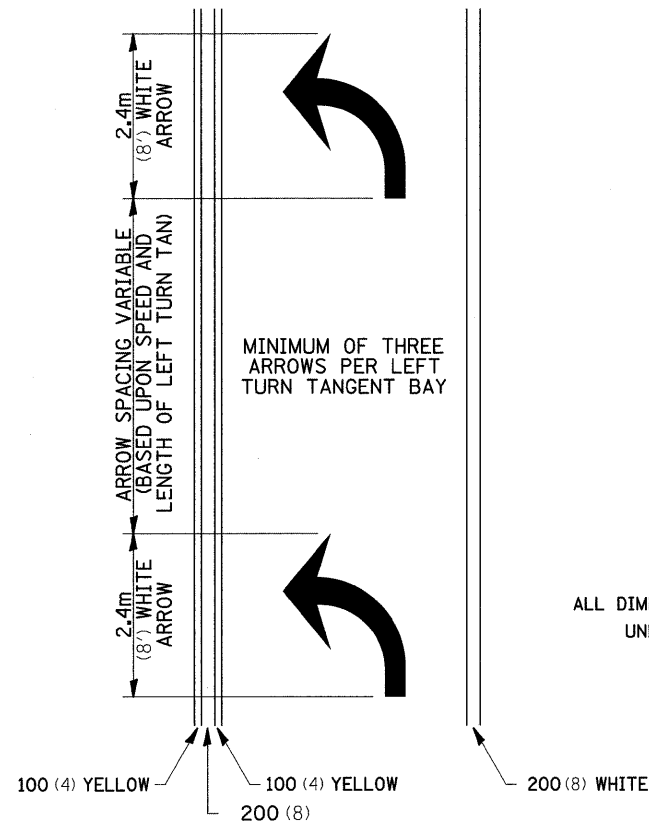

12.2m  
6 at (40') O.C.  
APPROACH SIDE ONLY

## TYPICAL PAVEMENT MARKING FOR FLUSH MEDIAN

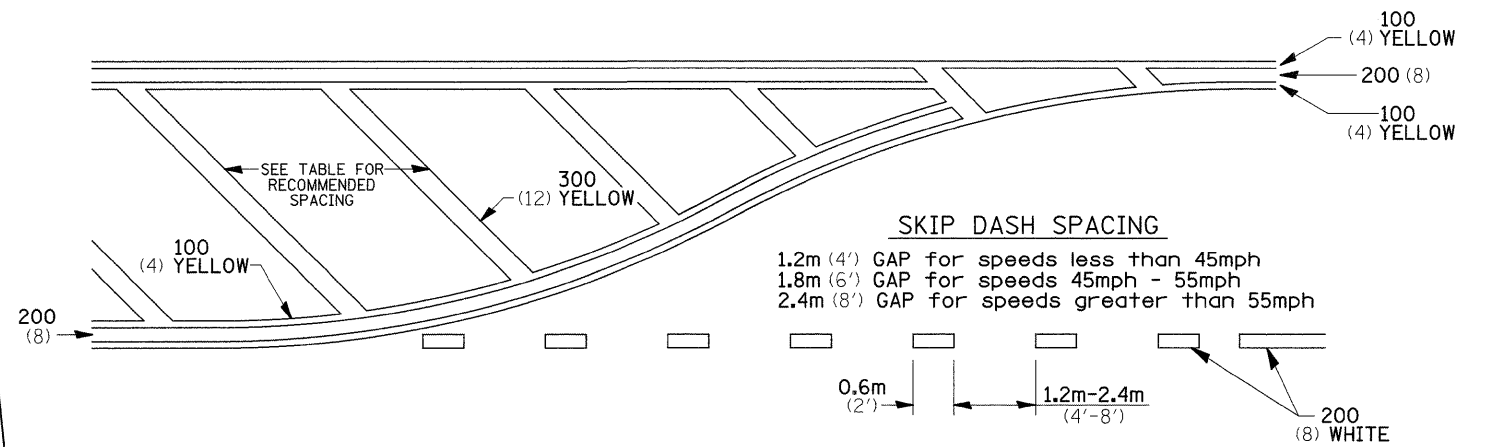

## RECOMMENDED SPACING BETWEEN DIAGONALS (IN FEET)

Speed Limit Range	Continuous Median Area	Intersection Channelization	Objects (Islands)
less than 50Km/H (30MPH)	15.3m (50')	4.53m (15')	3.05m (10')
50-60Km/H (30-40MPH)	22.9m (75')	6.1m (20')	4.53m (15')
70Km/H (45MPH) & over	22.9m (75')	9.05m (30')	6.1m (20')

NOTE: If the spacing recommended in the Table does not permit at least five diagonal lines in the area being marked, the spacing from the next lowest speed range should be used. The recommended spacing is measured parallel to the pavement center line.

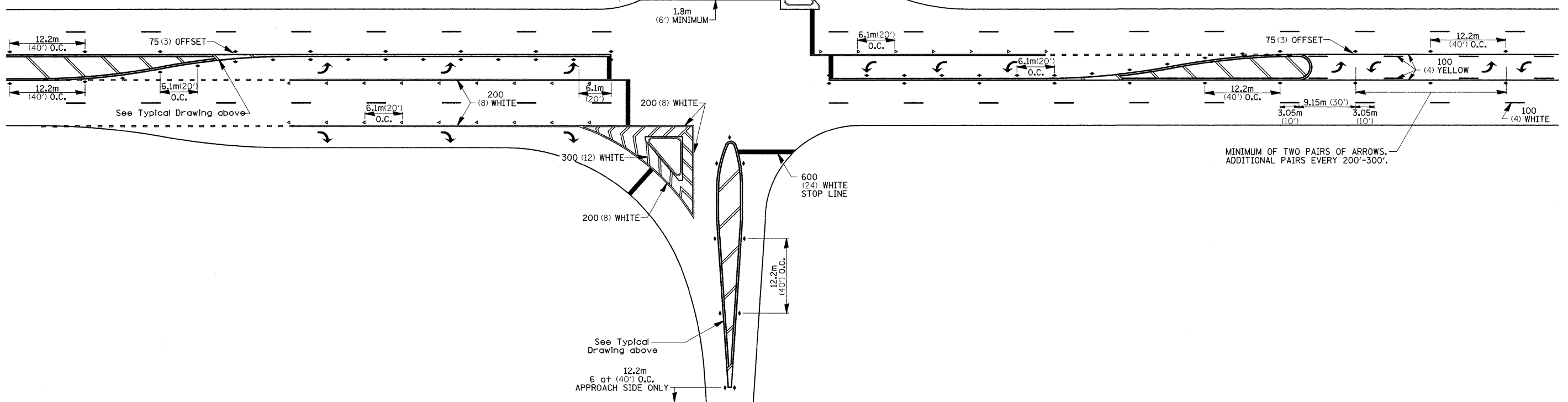

FILE NAME =	USER NAME = grantpm	DESIGNED -	REVISED - 10-21-08	<b>STATE OF ILLINOIS DEPARTMENT OF TRANSPORTATION</b>	<b>REGION 2 / DISTRICT 2 STANDARD</b>			F.A.P. RTE.	SECTION	COUNTY	TOTAL SHEETS	SHEET NO.
oi\pwork\pwidot\GRANTPM\dms31213\086628spl.dgn		DRAWN -	REVISED -					742	37R-4	OGLE	867	480
PLOT SCALE = 50.0000' / IN.		CHECKED -	REVISED -					CONTRACT NO. 64E17				
PLOT DATE = Tue Mar 30 09:22:43 2010		DATE -	REVISED -					FED. ROAD DIST. NO. [ILLINOIS] FED. AID PROJECT				



# TYPICAL PAVEMENT MARKINGS

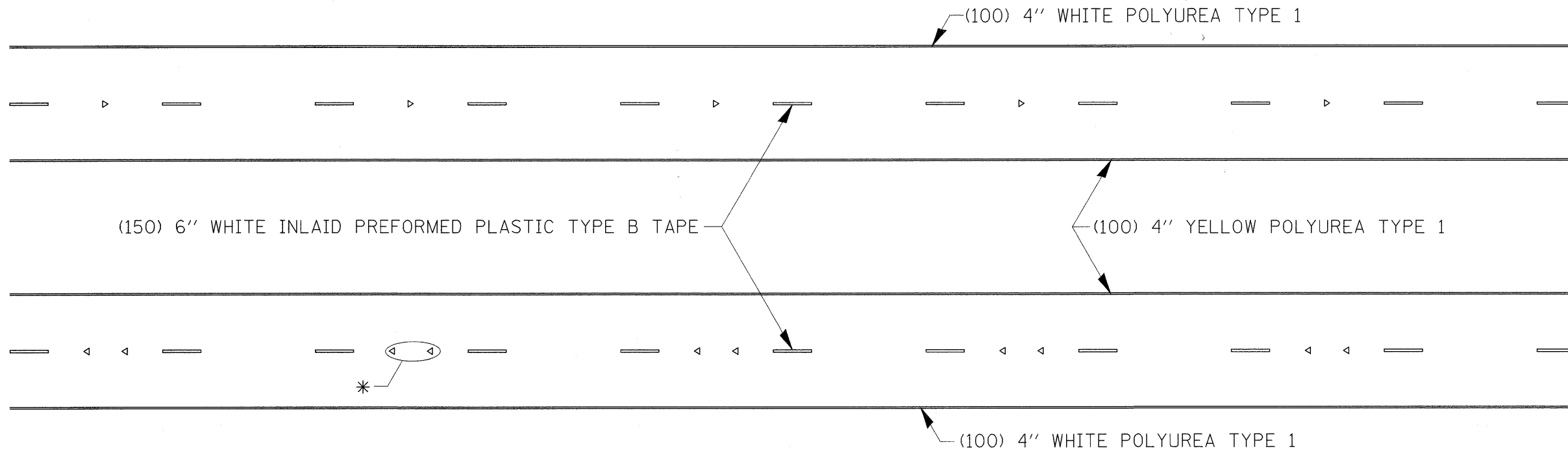

## MULTI-LANE / DIVIDED

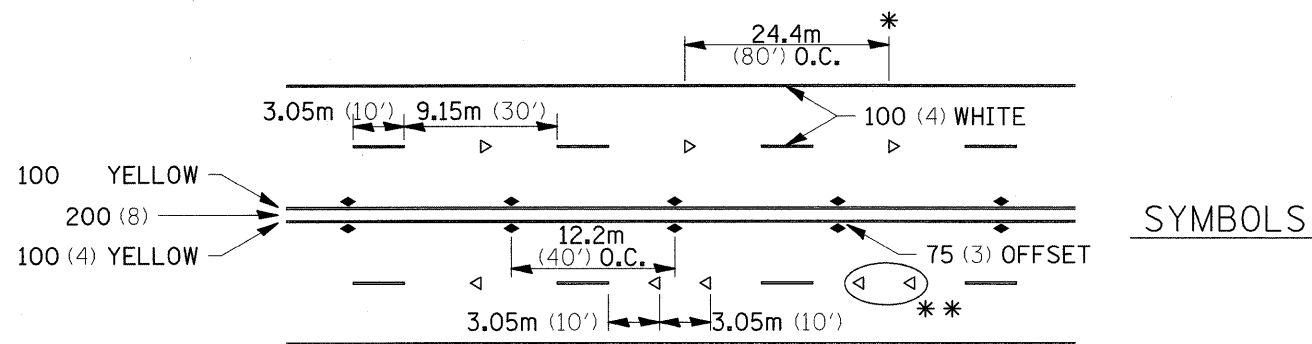

## MULTI-LANE / UNDIVIDED

## TYPICAL PAVEMENT MARKING FOR TWO LANE SECTION - NO PASSING ZONES

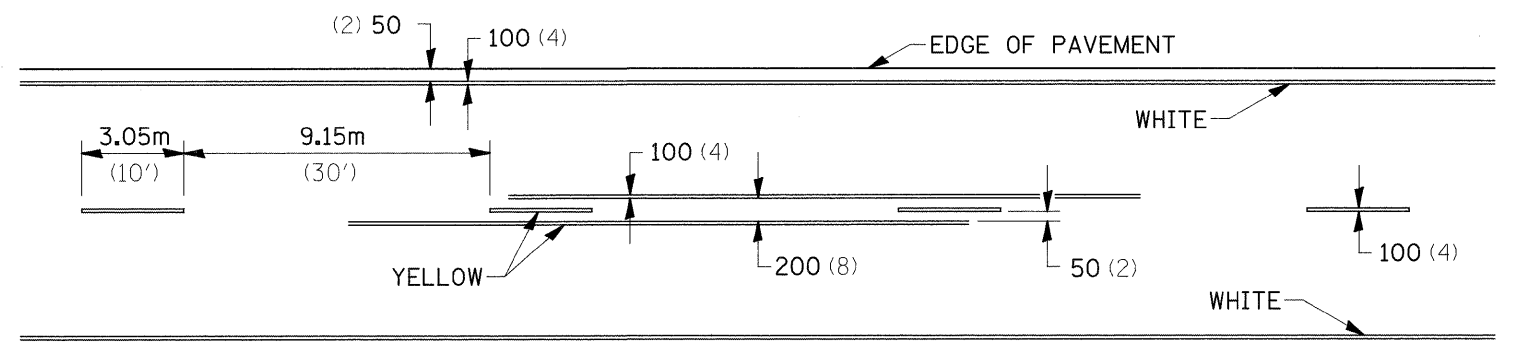

FILE NAME =	USER NAME = grantpm	DESIGNED -	REVISED - 10-21-08	<b>STATE OF ILLINOIS DEPARTMENT OF TRANSPORTATION</b>	<b>REGION 2 / DISTRICT 2 STANDARD</b>			F.A.P. RTE. 742	SECTION 37R-4	COUNTY OGLE	TOTAL SHEETS 867	SHEET NO. 481
CONTRACT NO. 64E17	PLOT SCALE = 50.0000' / IN.	CHECKED -	REVISED -					SCALE:	SHEET NO.	OF SHEETS	STA.	TO STA.
	PLOT DATE = Tue Mar 30 09:22:44 2010	DATE -	REVISED -									

# DETAILS OF PLANTING AND BRACING TREES

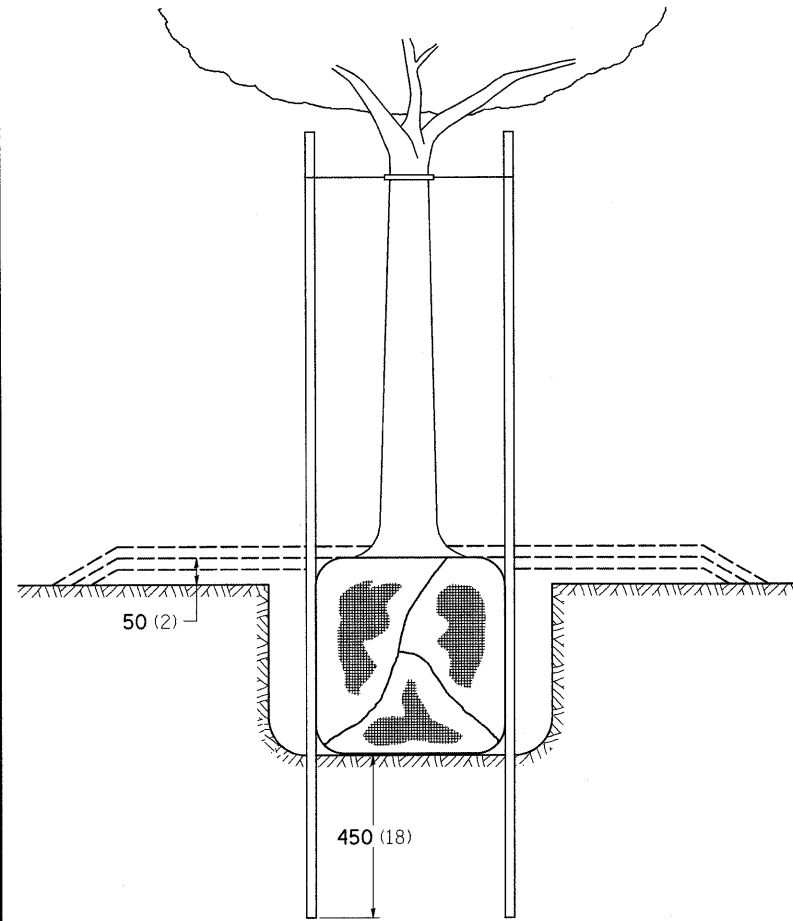

TREES SMALLER THAN 115 (4 1/2) IN DIAMETER

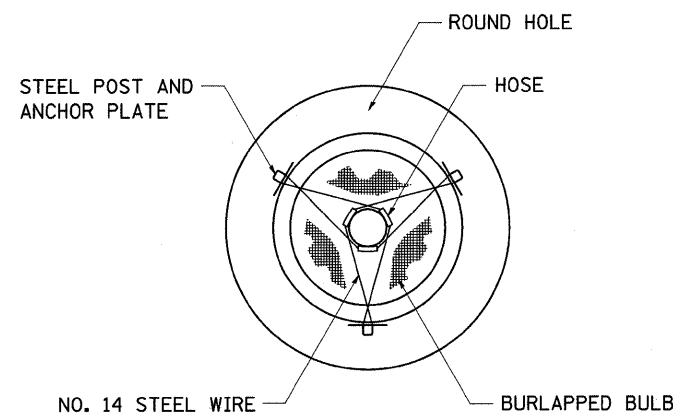

SMALL	A	B	C	D	E	F
TREE SIZE	DIAMETER OF BALL OR ROOT SYS.	DEPTH OF HOLE EXCAVATION	WIDTH OF HOLE EXCAVATION	THICKNESS OF MULCH COVER	DEPTH OF BALL OR ROOT SYS.	VOLUME OF MULCH COVER m <sup>3</sup> (CU. YDS.)
1.5-1.8m (5'-6')	400 (16)	250 (10)	750 (30)	100 (4)	300 (12)	0.41 (0.54)
1.5-1.8m (5'-6') BB	400 (16)	250 (10)	750 (30)	100 (4)	300 (12)	0.41 (0.54)
1.8-2.0m (6'-7') BB	450 (18)	300 (12)	750 (30)	100 (4)	350 (14)	0.41 (0.54)
2.0-2.4m (7'-8') BB	500 (20)	275 (11)	750 (30)	100 (4)	325 (13)	0.41 (0.54)
2.4-3.0m (8'-10') BB	600 (24)	350 (14)	900 (36)	100 (4)	400 (16)	0.47 (0.61)
3.0-3.6m (10'-12') BB	650 (26)	375 (15)	900 (36)	100 (4)	425 (17)	0.47 (0.61)

LARGE	A	B	C	D	E	F
TREE SIZE	DIAMETER OF BALL OR ROOT SYS.	DEPTH OF HOLE EXCAVATION	WIDTH OF HOLE EXCAVATION	THICKNESS OF MULCH COVER	DEPTH OF BALL OR ROOT SYS.	VOLUME OF MULCH COVER m <sup>3</sup> (CU. YDS.)
0-50 (0-2)	500 (20)	275 (11)	900 (36)	100 (4)	325 (13)	0.47 (0.61)
50-65 (2-2 1/2) BB	600 (24)	350 (14)	1200 (48)	100 (4)	400 (16)	0.60 (0.78)
65-75 (2 1/2-3) BB	700 (28)	425 (17)	1200 (48)	100 (4)	475 (19)	0.60 (0.78)
75-90 (3-3 1/2) BB	800 (32)	425 (17)	1500 (60)	100 (4)	475 (19)	0.73 (0.96)
90-100 (3 1/2-4) BB	900 (36)	500 (20)	1500 (60)	100 (4)	550 (22)	0.73 (0.96)
100-115 (4-4 1/2) BB	1000 (40)	550 (22)	1800 (72)	100 (4)	600 (24)	0.89 (1.16)
115-125 (4 1/2-5) BB	1100 (44)	600 (24)	1800 (72)	100 (4)	650 (26)	0.89 (1.16)
125-140 (5-5 1/2) BB	1200 (48)	675 (27)	2100 (84)	100 (4)	725 (29)	1.06 (1.38)

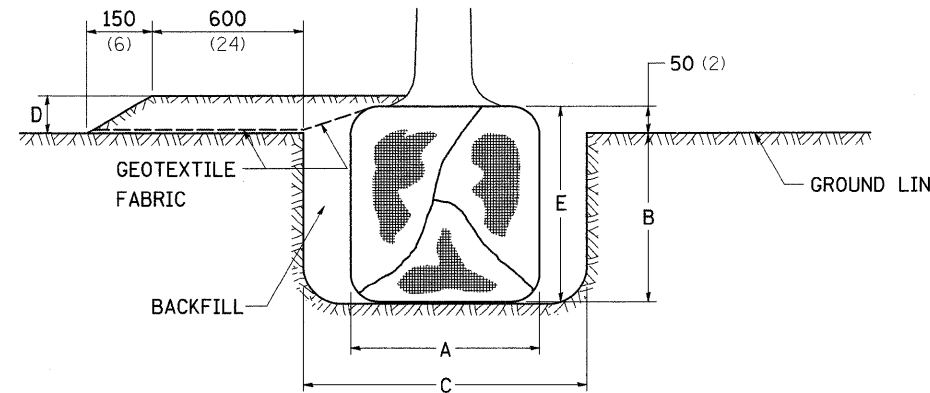

TREES OVER 115 (4 1/2) IN DIAMETER

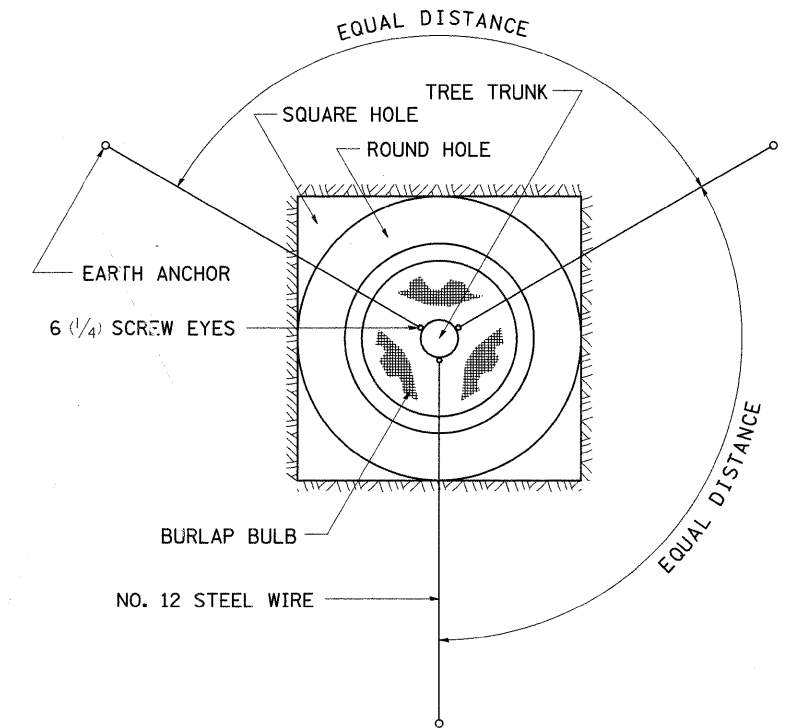
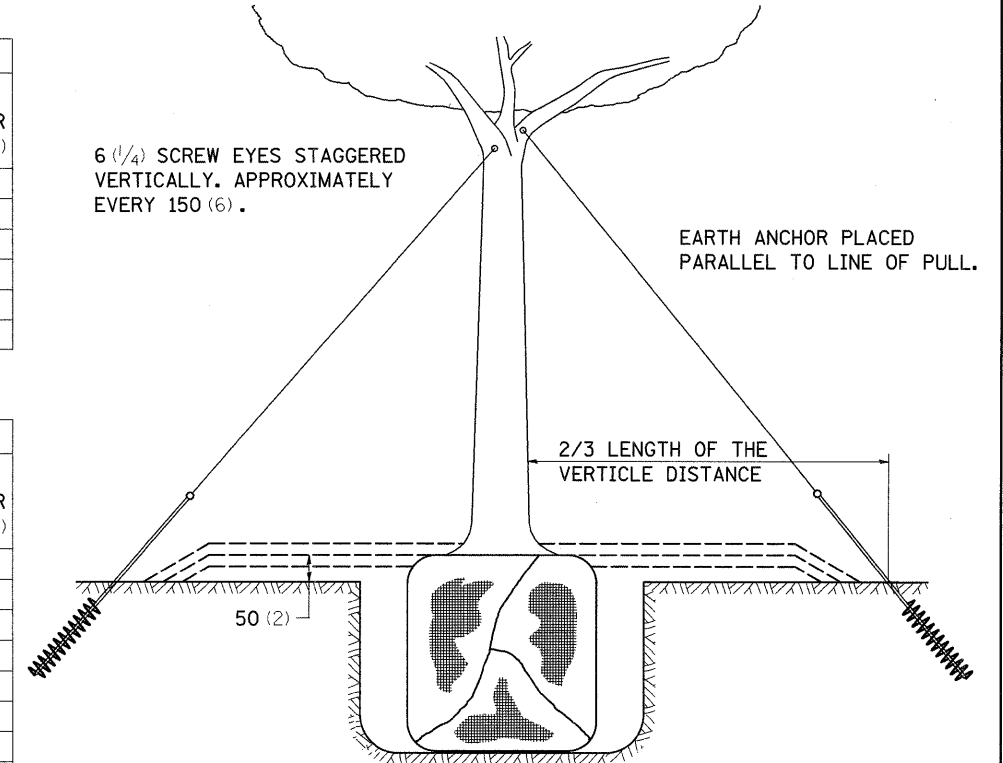

ALL DIMENSIONS ARE IN MILLIMETERS (INCHES) UNLESS OTHERWISE NOTED.

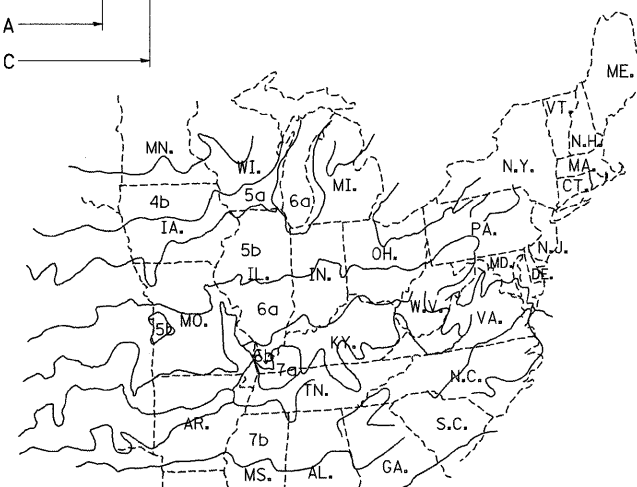

PLANT HARDINESS ZONE MAP

U.S. DEPARTMENT OF AGRICULTURE  
AGRICULTURAL RESEARCH SERVICE  
PUBLICATION NO. 814

FILE NAME =	USER NAME = grantpm	DESIGNED -	REVISED - 10-15-04	<b>STATE OF ILLINOIS DEPARTMENT OF TRANSPORTATION</b>	<b>REGION 2 / DISTRICT 2 STANDARD</b>	F.A.P. RTE.	SECTION	COUNTY	TOTAL SHEETS	SHEET NO.
ca\pw_work\PW\DOT\GRANTPM\dms31213\066808sp1.dgn		DRAWN -	REVISED -			742	37R-4	OGLE	867	482
PLOT SCALE = 50.0000 / IN.		CHECKED -	REVISED -			CONTRACT NO. 64E17				
PLOT DATE = Tue Mar 30 09:22:45 2010		DATE -	REVISED -			FED. ROAD DIST. NO. ILLINOIS FED. AID PROJECT				

FINAL SURVEY	DATE
SURVEYED	BY
PLANNED	
FIELD	
NOTE BOOK	
NO.	
AREAS CHECKED	

ORIGINAL SURVEY	DATE
SURVEYED	BY
PLANNED	
FIELD	
NOTE BOOK	
NO.	
AREAS CHECKED	

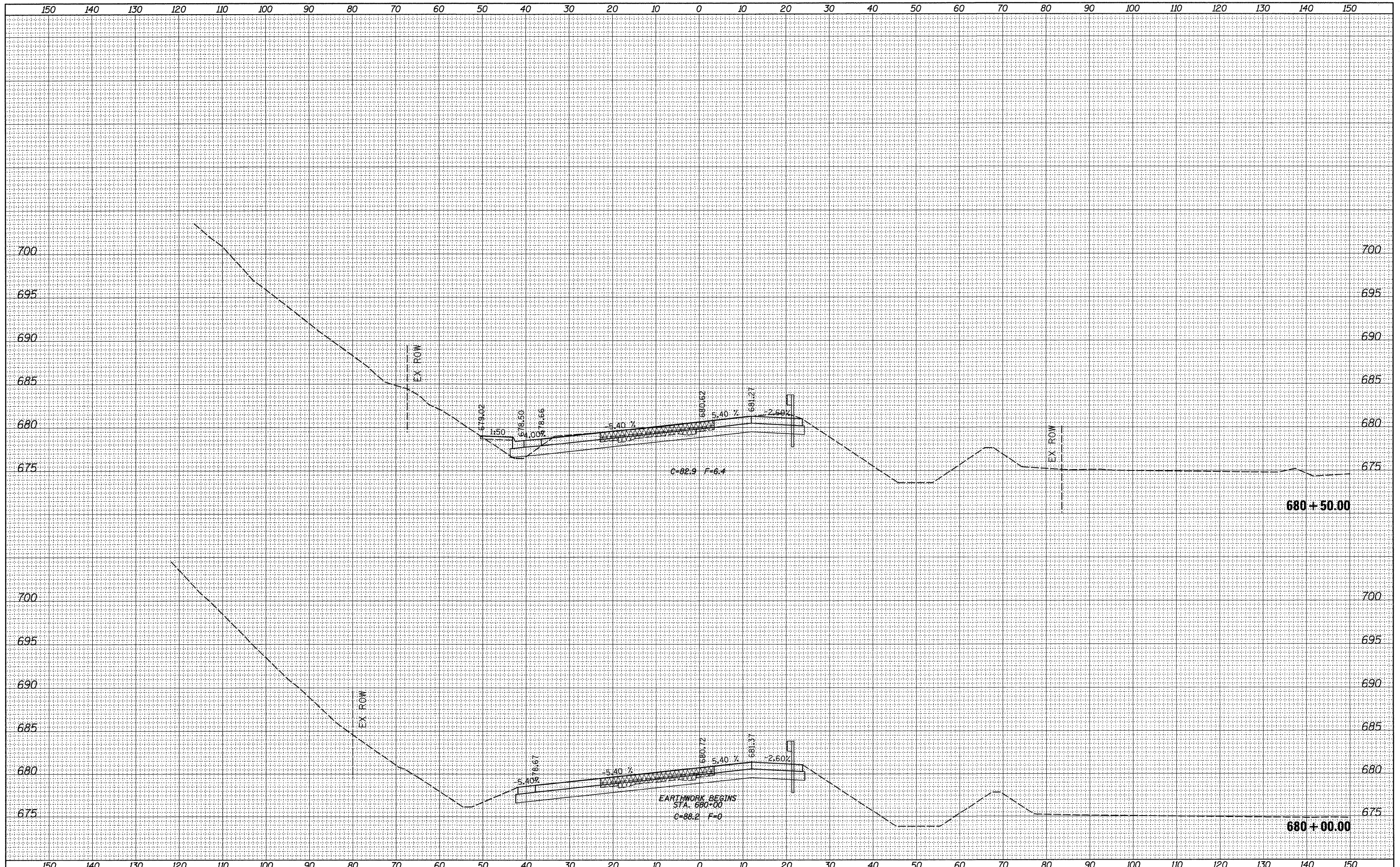

FILE NAME =	USER NAME = grantpm	DESIGNED -	REVISED -	<b>STATE OF ILLINOIS DEPARTMENT OF TRANSPORTATION</b>	<b>IL ROUTE 2 CROSS-SECTIONS</b>				F.A.P. RTE. 742	SECTION 37R-4	COUNTY OGLE	TOTAL SHEETS 867	SHEET NO. 483
cr:\pw_work\PWIDOT\GRANTPM\dms31213\0206680xms	.tldgn	DRAWN -	REVISED -		SCALE:	SHEET NO.	OF	SHEETS	STA. 680+00.00	TO STA. 680+50.00	CONTRACT NO. 64E17		
		CHECKED -	REVISED -		ILLINOIS FED. AID PROJECT								
		DATE -	REVISED -										

BY	DATE
SURVEYED	
NOTE BOOK	
TEMPLATE	
AREAS	
CHECKED	

BY	DATE
SURVEYED	
NOTE BOOK	
TEMPLATE	
AREAS	
CHECKED	

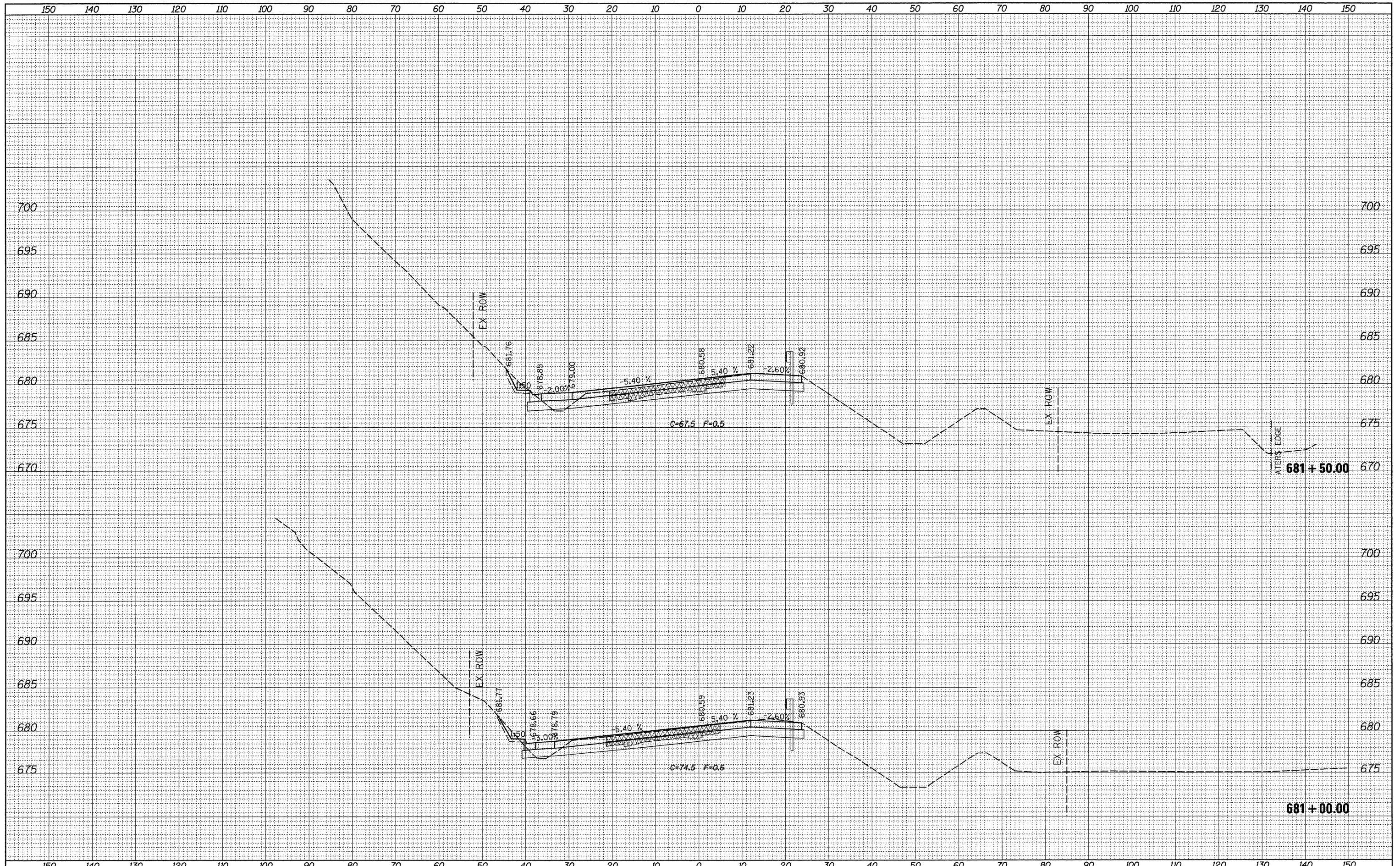

FILE NAME =	USER NAME = grantpm	DESIGNED -	REVISED -	<b>STATE OF ILLINOIS</b> <b>DEPARTMENT OF TRANSPORTATION</b>	<b>IL ROUTE 2</b> <b>CROSS-SECTIONS</b>		F.A.P. RTE.	SECTION	COUNTY	TOTAL SHEETS	SHEET NO.
as\p\work\FWIDOT\GRANTPM\dms31213\0286608.xml	tl.dgn	DRAWN -	REVISED -		742	37R-4	OGLE	867	484		
PLOT SCALE = 10,0000' / IN.		CHECKED -	REVISED -		SCALE: SHEET NO. OF SHEETS STA. 681+00.00 TO STA. 681+50.00		CONTRACT NO. 64E17		ILLINOIS FED. AID PROJECT		
PLOT DATE = Tue Mar 30 14:22:25 2010		DATE -	REVISED -								

BY	DATE
SURVEYED	
PLOTTED	
TEMPLATE	
NOTE BOOK	
NO.	
AREAS CHECKED	

BY	DATE
SURVEYED	
PLOTTED	
TEMPLATE	
NOTE BOOK	
NO.	
AREAS CHECKED	

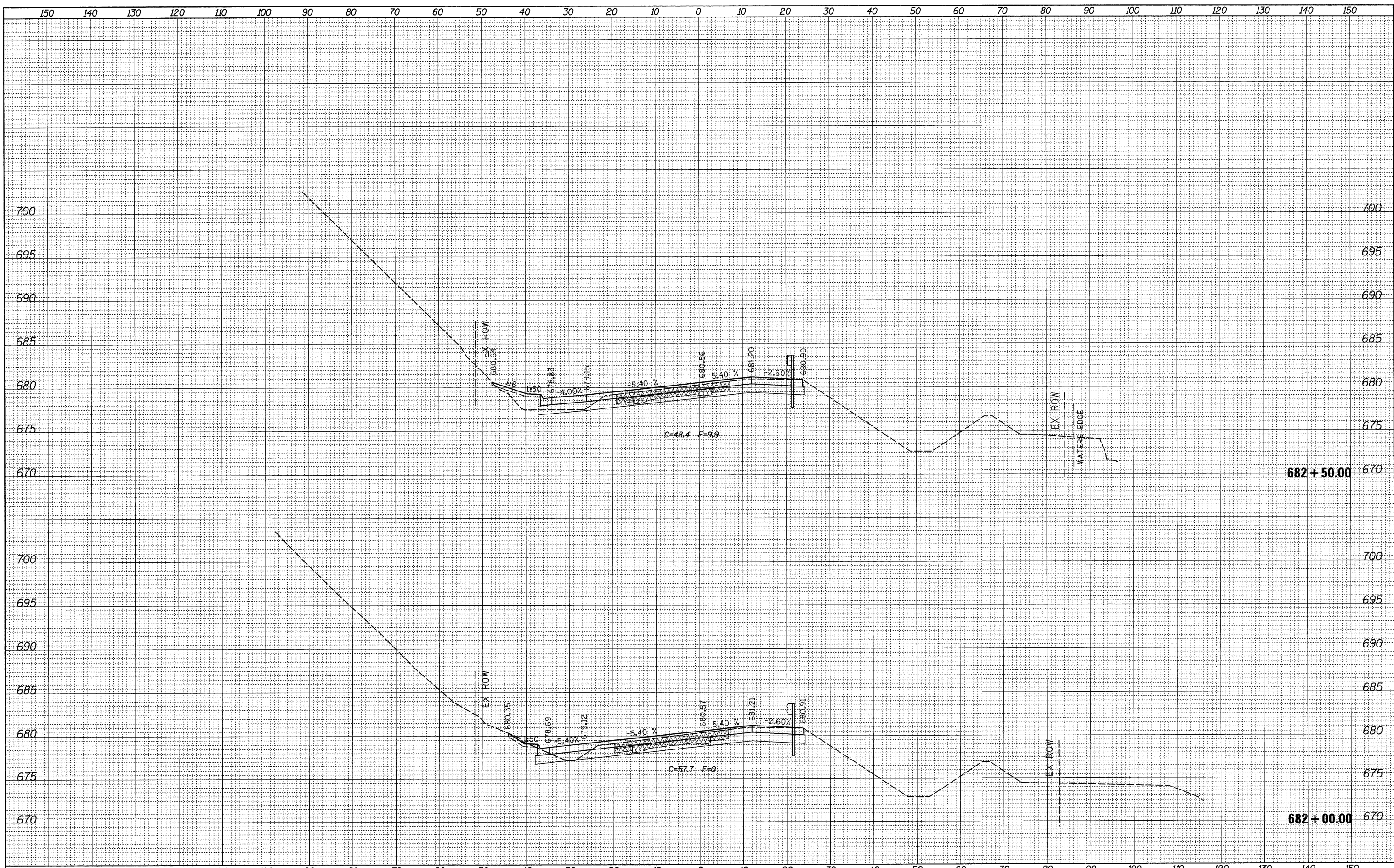

FILE NAME =  
 USER NAME = grantpm  
 PLOT SCALE = 10.0000' / IN.  
 PLOT DATE = Tue Mar 30 14:02:26 2010

DESIGNED -  
 DRAWN -  
 CHECKED -  
 DATE -

REVISED -  
 REVISED -  
 REVISED -  
 REVISED -

**STATE OF ILLINOIS  
 DEPARTMENT OF TRANSPORTATION**

**IL ROUTE 2  
 CROSS-SECTIONS**

SCALE: SHEET NO. OF SHEETS STA. 682+00.00 TO STA. 682+50.00

F.A.P. RTE.	SECTION	COUNTY	TOTAL SHEETS	SHEET NO.
742	37R-4	OGLE	867	485
CONTRACT NO. 64E17			ILLINOIS FED. AID PROJECT	

DATE	
BY	
FINAL SURVEY	
PLOTTED	
TEMPLATE	
NOTE BOOK	
AREAS CHECKED	
NO.	

DATE	
BY	
ORIGINAL SURVEY	
PLOTTED	
TEMPLATE	
NOTE BOOK	
AREAS CHECKED	
NO.	

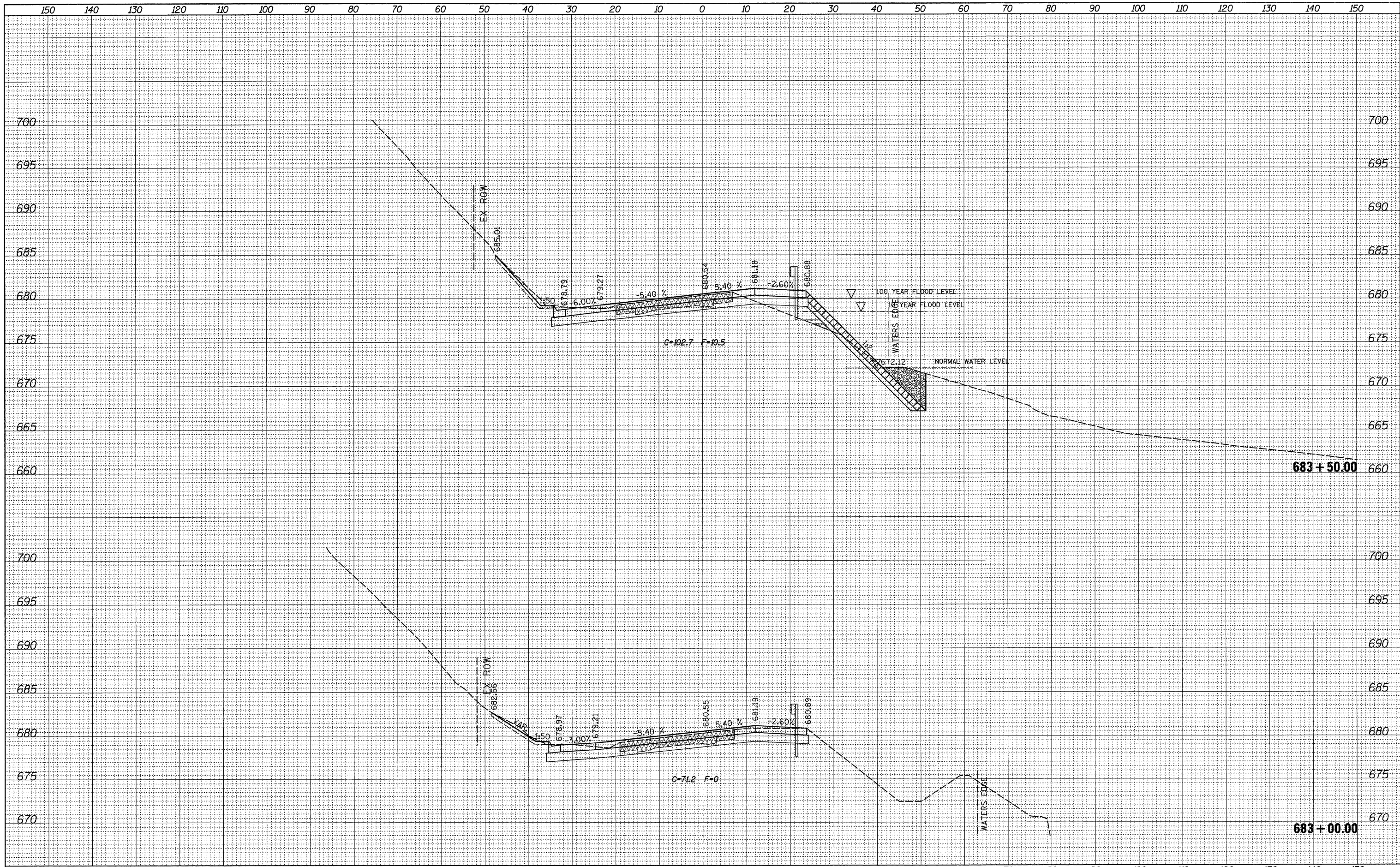

FILE NAME =  
 c:\pwwork\p\WIDOT\GRANTPM\dms31213\02066008\msd1.dgn

USER NAME = grantpm  
 PLOT SCALE = 10.0000' / IN.  
 PLOT DATE = Tue Mar 30 14:02:27 2010

DESIGNED -  
 DRAWN -  
 CHECKED -  
 DATE -

REVISED -  
 REVISED -  
 REVISED -  
 REVISED -

**STATE OF ILLINOIS  
 DEPARTMENT OF TRANSPORTATION**

**IL ROUTE 2  
 CROSS-SECTIONS**

SCALE: SHEET NO. OF SHEETS STA. 683+00.00 TO STA. 683+50.00

F.A.P. RTE. 742	SECTION 37R-4	COUNTY OGLE	TOTAL SHEETS 867	SHEET NO. 486
CONTRACT NO. 64E17			ILLINOIS FED. AID PROJECT	

BY	DATE
SURVEYED	
PLOTTED	
TEMPLATE	
NOTE BOOK	
AREAS	CHECKED
NO.	

BY	DATE
ORIGINAL SURVEY	
PLOTTED	
TEMPLATE	
NOTE BOOK	
AREAS	CHECKED
NO.	

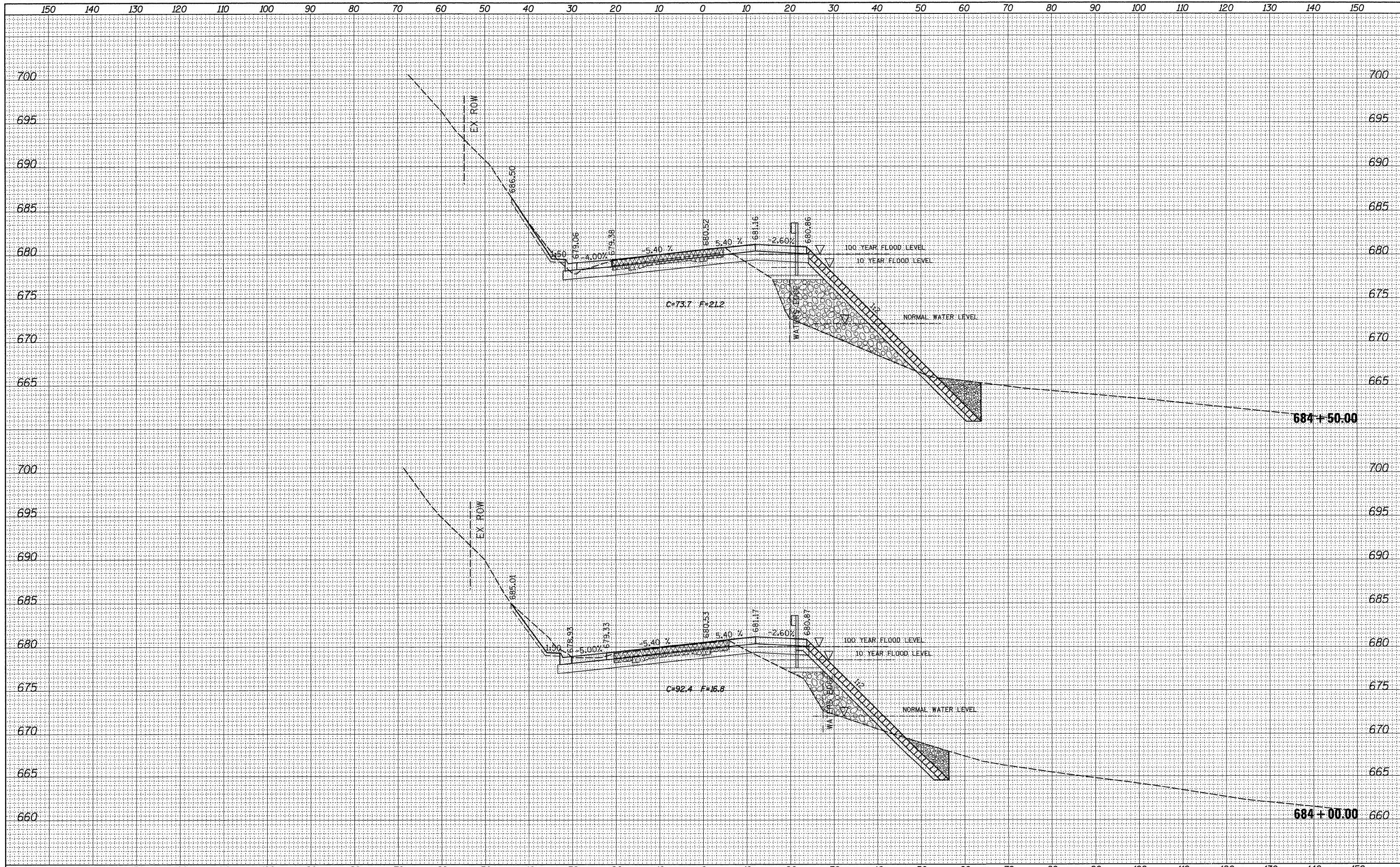

FILE NAME =	USER NAME = grantpm	DESIGNED -	REVISED -	STATE OF ILLINOIS DEPARTMENT OF TRANSPORTATION		IL ROUTE 2 CROSS-SECTIONS		F.A.P. RTE. 742	SECTION 37R-4	COUNTY OGLE	TOTAL SHEETS 867	SHEET NO. 487
et\pwwork\p\WIDOT\GRANTPM\dms31213\020608\dms31213.dgn		DRAWN -	REVISED -	SCALE:		SHEET NO. OF SHEETS		STA. 684+00.00 TO STA. 684+50.00		CONTRACT NO. 64E17		
PLOT SCALE = 10,0000' / IN.		CHECKED -	REVISED -							ILLINOIS FED. AID PROJECT		
PLOT DATE = Tue Mar 30 14:02:28 2010		DATE -	REVISED -									

BY	DATE
SURVEYED	
REVISIONS	
TEMPLATE	
NOTE BOOK	
AREAS CHECKED	
NO.	

BY	DATE
SURVEYED	
REVISIONS	
TEMPLATE	
NOTE BOOK	
AREAS CHECKED	
NO.	

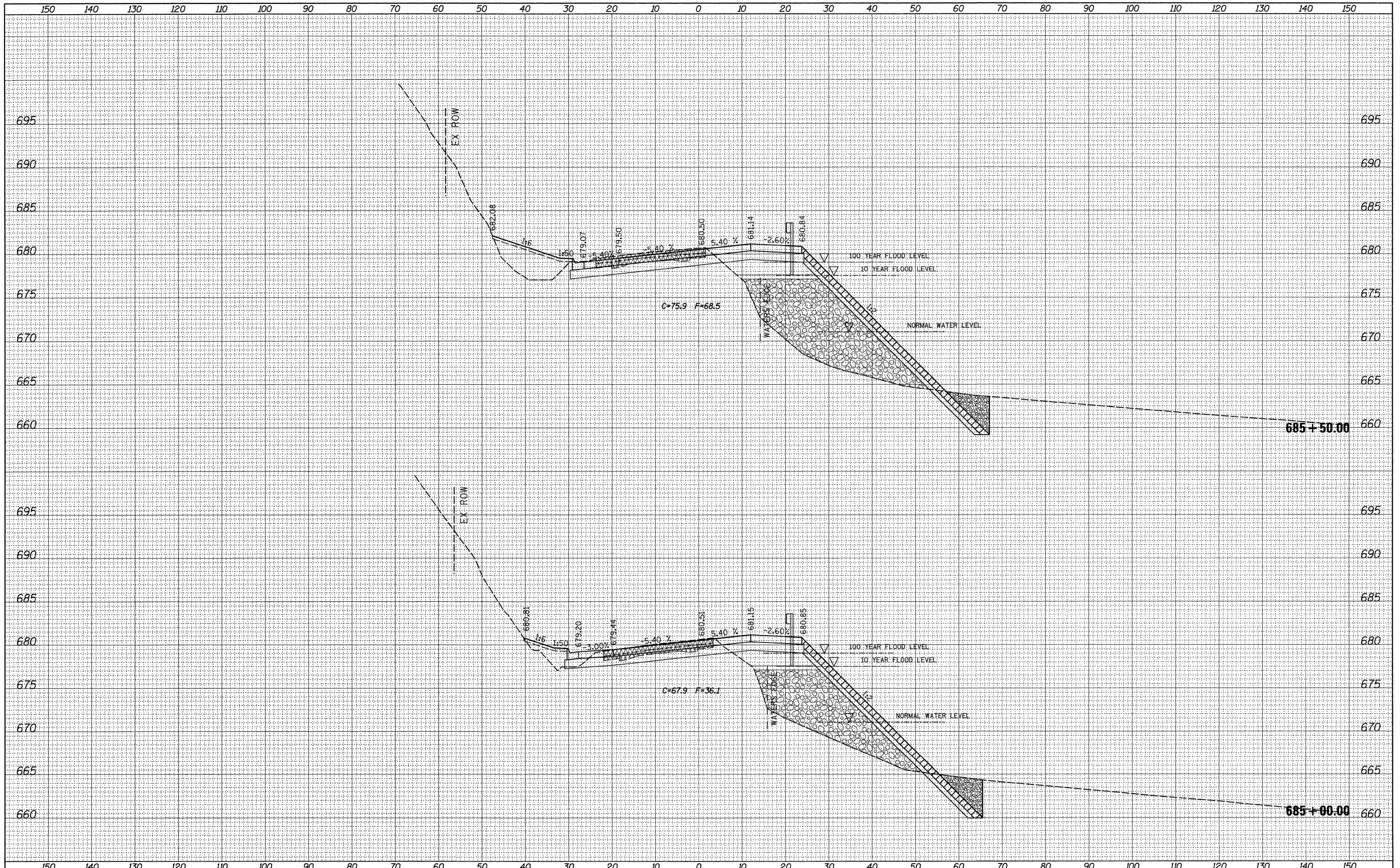

FILE NAME =	USER NAME = grantpm	DESIGNED -	REVISED -	<b>STATE OF ILLINOIS DEPARTMENT OF TRANSPORTATION</b>	<b>IL ROUTE 2 CROSS-SECTIONS</b>	F.A.P. RTE.	SECTION	COUNTY	TOTAL SHEETS	SHEET NO.	
c:\pw\work\FWIDOT\GRANTPM\dms31213\0206608xmas.tldgn	PLOT SCALE = 10,0000' / IN.	DRAWN -	REVISED -			742	37R-4	OGLE	867	488	
PLOT DATE = Tue Mar 30 14:02:29 2010	DATE -	CHECKED -	REVISED -			CONTRACT NO. 64E17		ILLINOIS FED. AID PROJECT			
		DATE -	REVISED -			SCALE:	SHEET NO. OF SHEETS	STA. 685+00.00 TO STA. 685+50.00			



DATE	
BY	
FINAL SURVEY	SURVEYED
NOTE BOOK NO.	PLOTTED
	TEMPLATE
	AREAS CHECKED

DATE	
BY	
ORIGINAL SURVEY	SURVEYED
NOTE BOOK NO.	PLOTTED
	TEMPLATE
	AREAS CHECKED

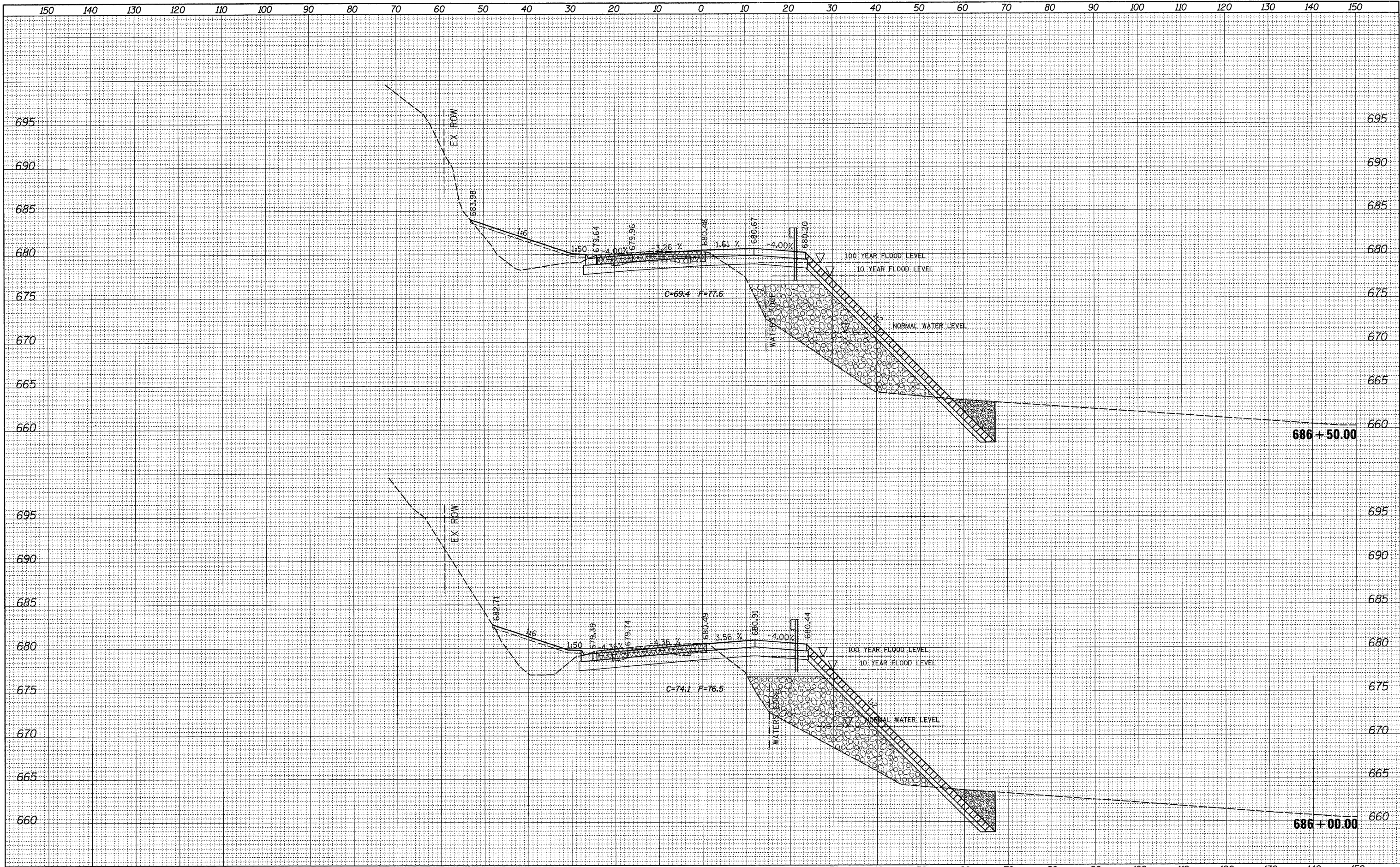

FILE NAME =	USER NAME = grantpm	DESIGNED -	REVISED -	<b>STATE OF ILLINOIS</b> <b>DEPARTMENT OF TRANSPORTATION</b>	<b>IL ROUTE 2</b> <b>CROSS-SECTIONS</b>		F.A.P. RTE.	SECTION	COUNTY	TOTAL SHEETS	SHEET NO.
et\pwwork\pwwid\GRANTPM\dms31213\0206608xms.tldgn		DRAWN -	REVISED -		742	37R-4	OGLE	867	489		
PLOT SCALE = 10.0000' / IN.		CHECKED -	REVISED -		SCALE:		SHEET NO. OF SHEETS		CONTRACT NO. 64E17		
PLOT DATE = Tue Mar 30 14:02:30 2010		DATE -	REVISED -		STA. 686+00.00 TO STA. 686+50.00		ILLINOIS FED. AID PROJECT				

DATE	
BY	
FINAL SURVEY	SURVEYED
NOTE BOOK NO.	PLOTTED
	TEMPLATE
	AREAS CHECKED

DATE	
BY	
ORIGINAL SURVEY	SURVEYED
NOTE BOOK NO.	PLOTTED
	TEMPLATE
	AREAS CHECKED

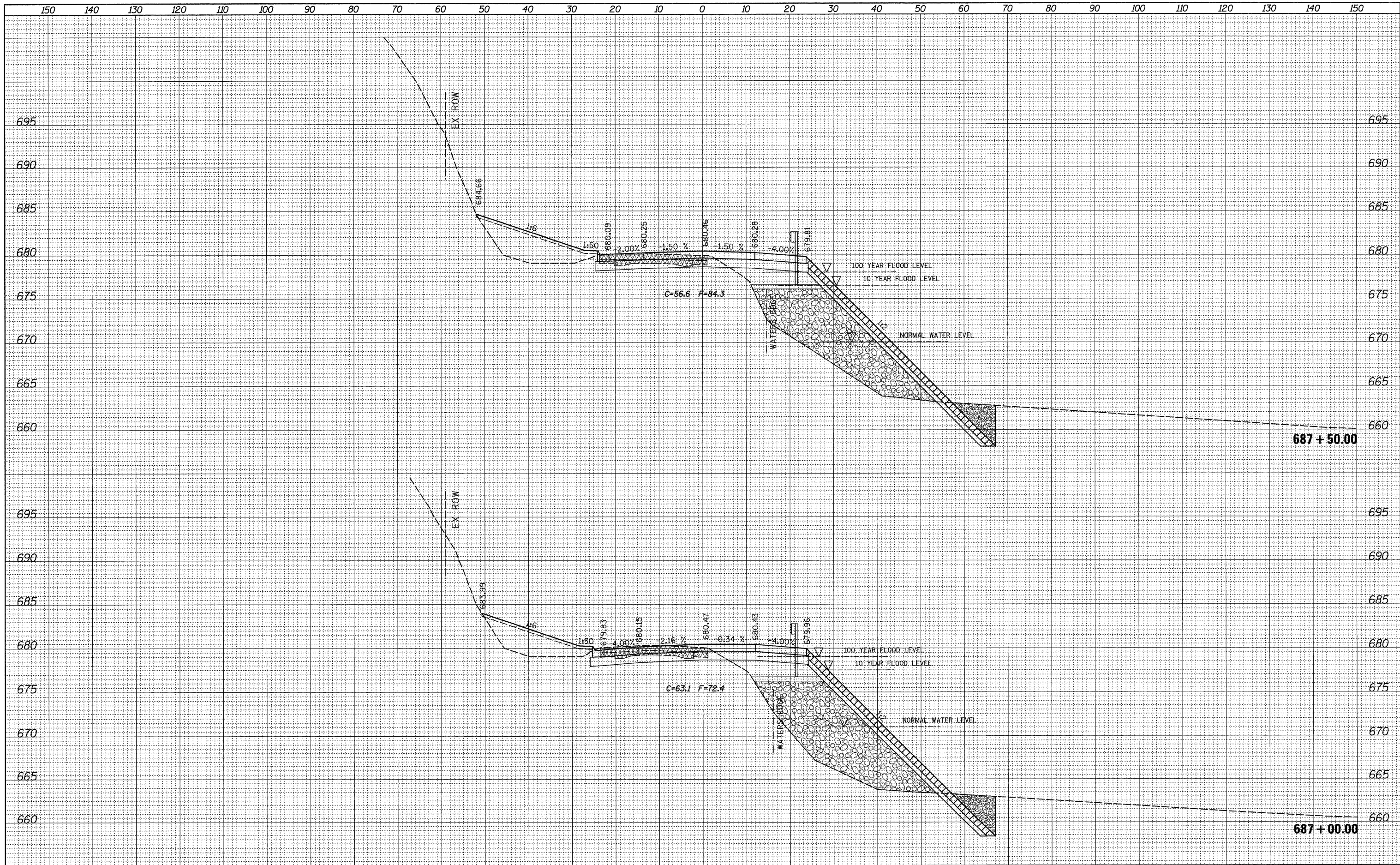

FILE NAME =	USER NAME = grantpm	DESIGNED -	REVISED -	<b>STATE OF ILLINOIS</b> <b>DEPARTMENT OF TRANSPORTATION</b>	<b>IL ROUTE 2</b> <b>CROSS-SECTIONS</b>	F.A.P. RTE.	SECTION	COUNTY	TOTAL SHEETS	SHEET NO.
ca\pw_wor-k\PWIDOT\GRANTPH\dms31213\206608xms1.dgn		DRAWN -	REVISED -			742	37R-4	OGLE	867	490
PLOT SCALE = 10.0000' / IN.		CHECKED -	REVISED -			CONTRACT NO. 64E17		ILLINOIS FED. AID PROJECT		
PLOT DATE = Tue Mar 30 14:02:32 2010		DATE -	REVISED -			SCALE:	SHEET NO. OF SHEETS	STA. 687+00.00 TO STA. 687+50.00		



DATE	
BY	
FINAL SURVEY	
SURVEYED	
PLOTTED	
TEMPLATE	
NOTE BOOK	
NO.	
AREAS CHECKED	

DATE	
BY	
ORIGINAL SURVEY	
SURVEYED	
PLOTTED	
TEMPLATE	
NOTE BOOK	
NO.	
AREAS CHECKED	

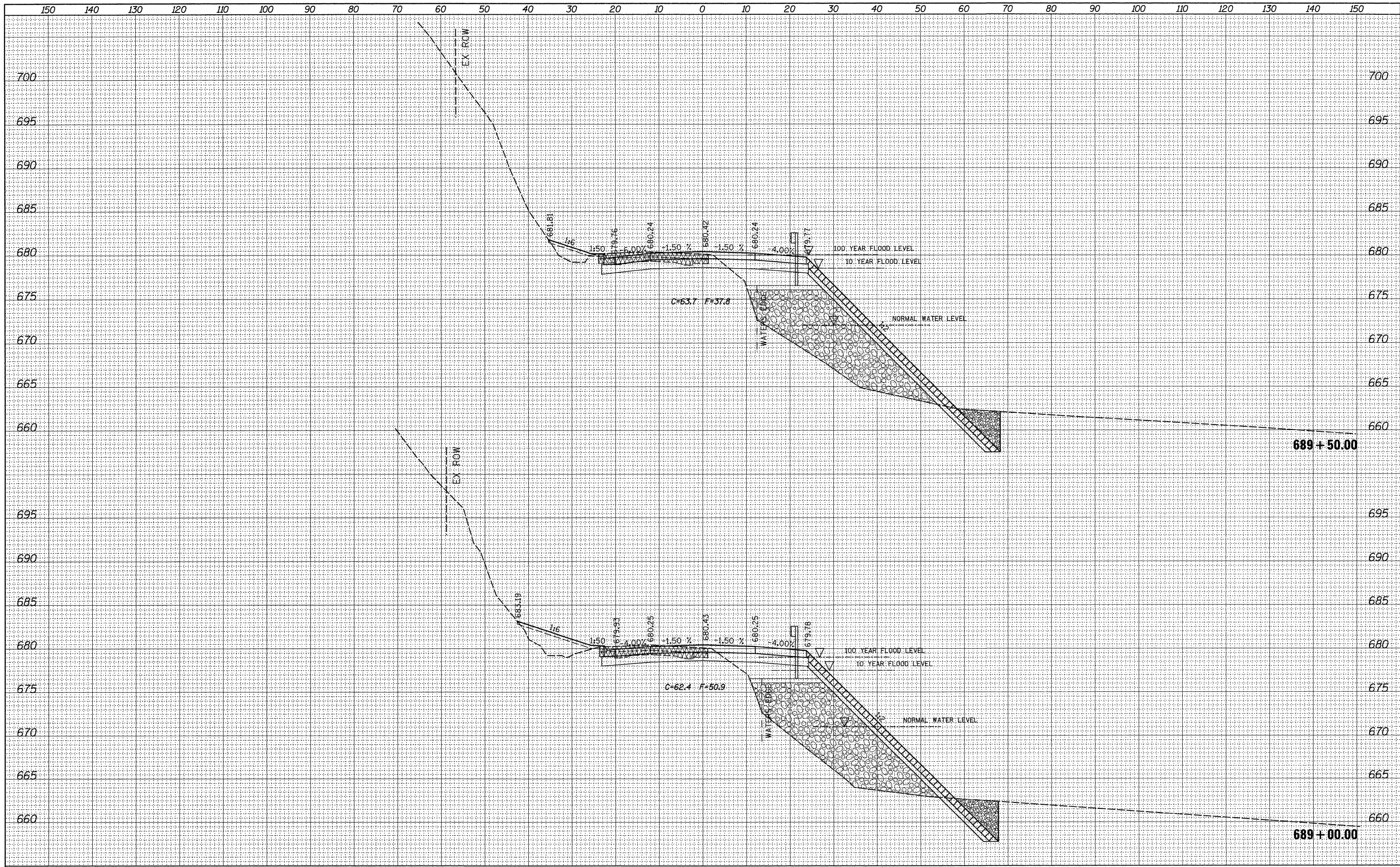

FILE NAME = c:\pwwork\pwidot\GRANTPM\dms31213\0206608\msa1.dgn  
 USER NAME = grantpm  
 PLOT SCALE = 10.0000 "/>

DESIGNED -  
 DRAWN -  
 CHECKED -  
 DATE -

REVISED -  
 REVISED -  
 REVISED -  
 REVISED -

**STATE OF ILLINOIS  
 DEPARTMENT OF TRANSPORTATION**

**IL ROUTE 2  
 CROSS-SECTIONS**

SCALE: SHEET NO. OF SHEETS STA. 689+00.00 TO STA. 689+50.00

F.A.P. RTE. 742	SECTION 37R-4	COUNTY OGLE	TOTAL SHEETS 867	SHEET NO. 492
CONTRACT NO. 64E17			ILLINOIS FED. AID PROJECT	

DATE	
BY	
FINAL SURVEY	SURVEYED
NOTE BOOK NO.	PLOTTED
	TEMPLATE
	AREAS CHECKED

DATE	
BY	
ORIGINAL SURVEY	SURVEYED
NOTE BOOK NO.	PLOTTED
	TEMPLATE
	AREAS CHECKED

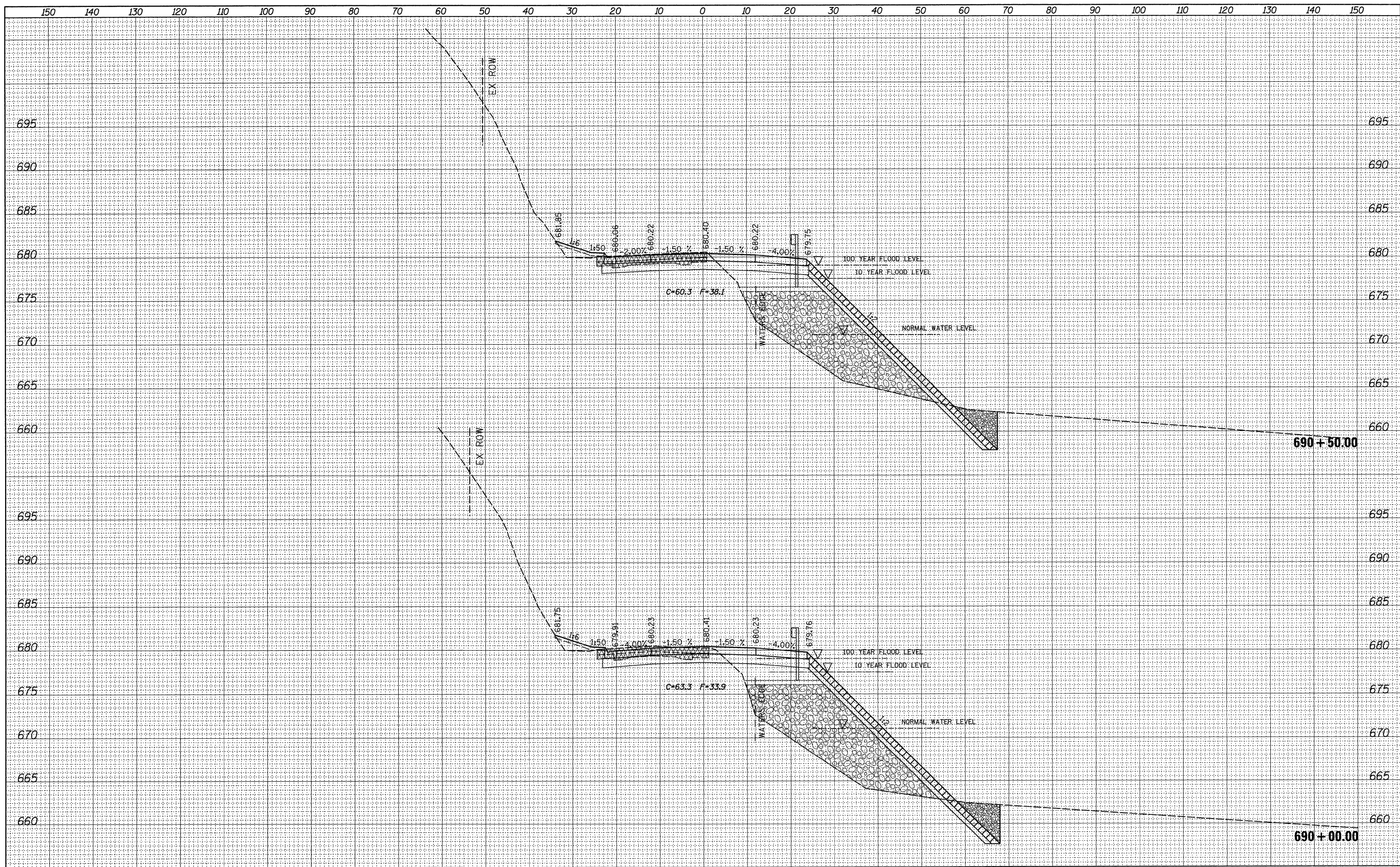

FILE NAME =	USER NAME = grantpm	DESIGNED -	REVISED -	<b>STATE OF ILLINOIS DEPARTMENT OF TRANSPORTATION</b>	<b>IL ROUTE 2 CROSS-SECTIONS</b>			F.A.P. RTE. 742	SECTION 3TR-4	COUNTY OGLE	TOTAL SHEETS 867	SHEET NO. 493
es:\pwwork\pwidot\GRANTPM\dms31213\0206608\kmsat1.dgn	PLOT SCALE = 10,0000' / IN.	DRAWN -	REVISED -		SCALE:	SHEET NO.	OF	SHEETS	STA. 690+00.00	TO STA. 690+50.00	CONTRACT NO. 64E17	
	PLOT DATE = Tue Mar 30 14:02:35 2010	CHECKED -	REVISED -									
		DATE -	REVISED -									
ILLINOIS FED. AID PROJECT												

BY	DATE
SURVEYED	
PLOTTED	
TEMPLATE	
NOTE BOOK	
NO.	
AREAS CHECKED	

BY	DATE
SURVEYED	
PLOTTED	
TEMPLATE	
NOTE BOOK	
NO.	
AREAS CHECKED	

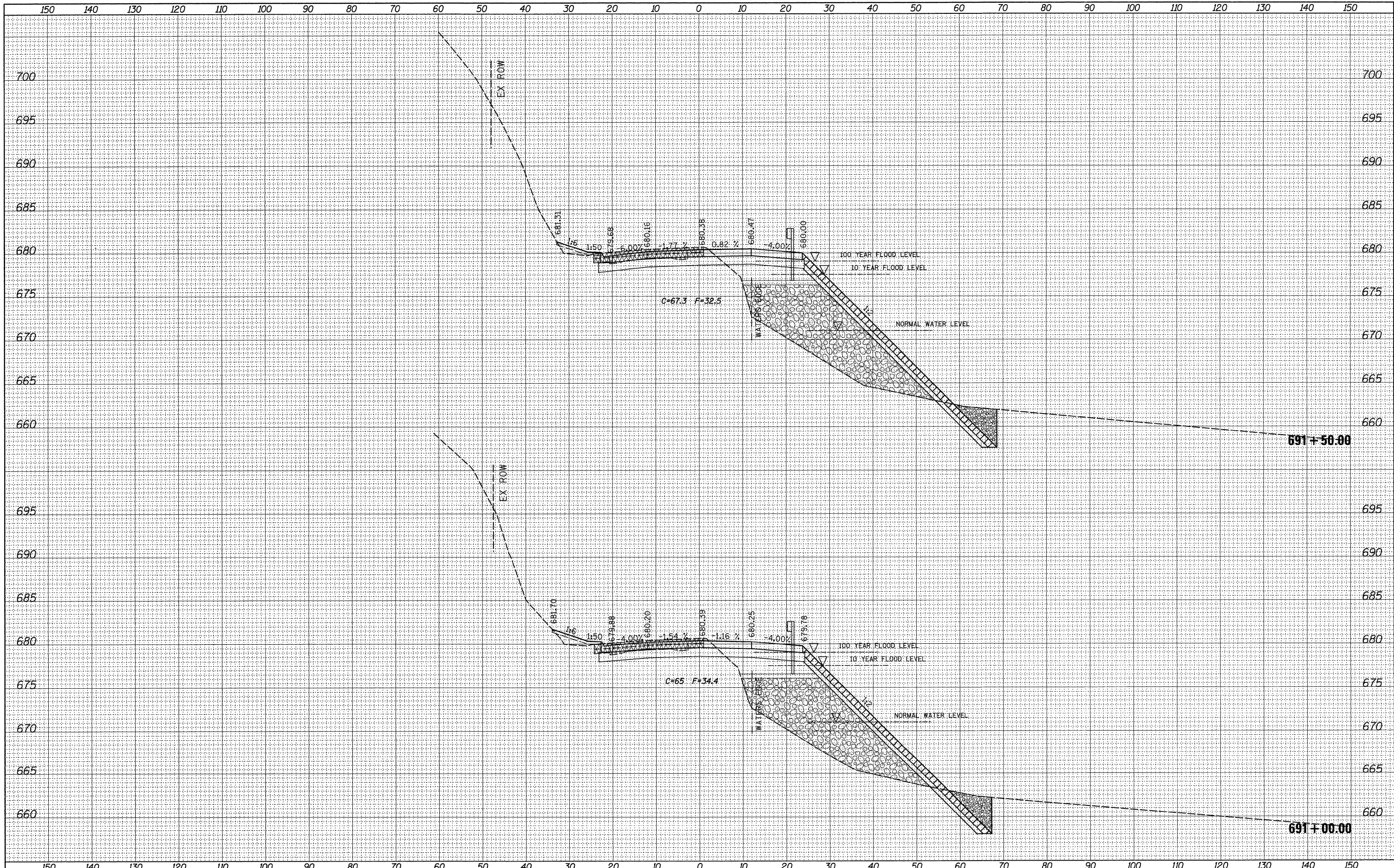

FILE NAME =	USER NAME = grantpm	DESIGNED -	REVISED -	<b>STATE OF ILLINOIS</b> <b>DEPARTMENT OF TRANSPORTATION</b>	<b>IL ROUTE 2</b> <b>CROSS-SECTIONS</b>	F.A.P. RTE.	SECTION	COUNTY	TOTAL SHEETS	SHEET NO.
ca\pw\work\p\WIDOT\GRANTPM\dms31213\0206608\msst.dgn		DRAWN -	REVISED -			742	37R-4	OGLE	867	494
PLOT SCALE = 10.0000' / IN.		CHECKED -	REVISED -			CONTRACT NO. 64E17		ILLINOIS FED. AID PROJECT		
PLOT DATE = Tue Mar 30 14:02:37 2010		DATE -	REVISED -			SCALE:	SHEET NO. OF SHEETS	STA. 691+00.00 TO STA. 691+50.00		

DATE	
BY	
SURVEYED	
PLOTTED	
TEMPLATE	
NOTE BOOK	
NO.	
AREAS CHECKED	

DATE	
BY	
SURVEYED	
PLOTTED	
TEMPLATE	
NOTE BOOK	
NO.	
AREAS CHECKED	

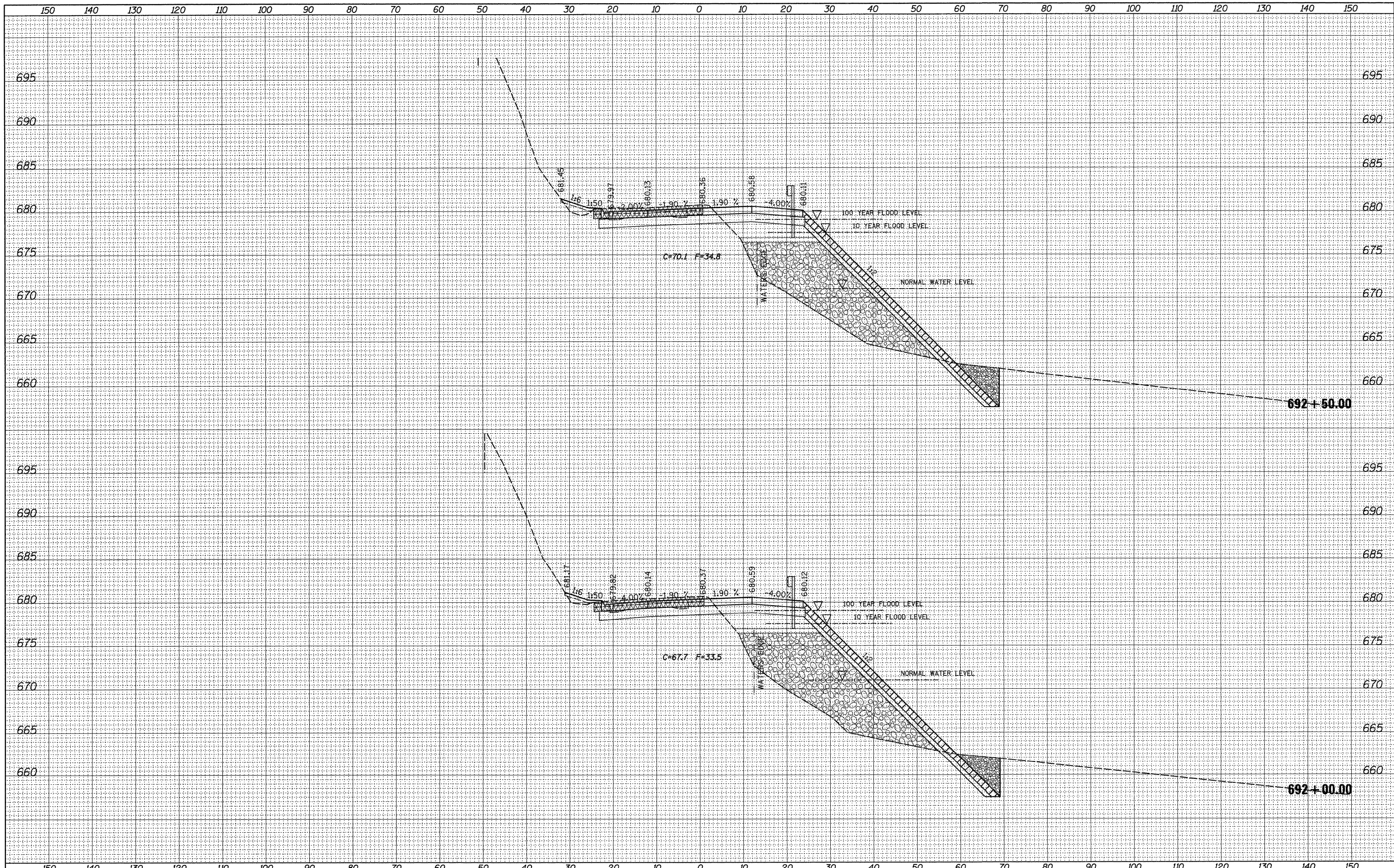

FILE NAME =	USER NAME = grantpm	DESIGNED -	REVISED -	<b>STATE OF ILLINOIS DEPARTMENT OF TRANSPORTATION</b>	<b>IL ROUTE 2 CROSS-SECTIONS</b>			F.A.P. RTE.	SECTION	COUNTY	TOTAL SHEETS	SHEET NO.
es:\pw\work\p\WIDOT\GRANTPM\dms31213\2066608xms	tl.dgn	DRAWN -	REVISED -		742	37R-4	OGLE	867	495			
PLOT SCALE = 10.0000' / IN.		CHECKED -	REVISED -		SCALE: SHEET NO. OF SHEETS STA. 692+00.00 TO STA. 692+50.00			CONTRACT NO. 64E17				
PLOT DATE = Tue Mar 30 14:02:38 2010		DATE -	REVISED -		ILLINOIS FED. AID PROJECT							

BY	DATE
SURVEYED	
NOTE BOOK	
TEMPLATE	
AREAS CHECKED	
NO.	

BY	DATE
SURVEYED	
NOTE BOOK	
TEMPLATE	
AREAS CHECKED	
NO.	

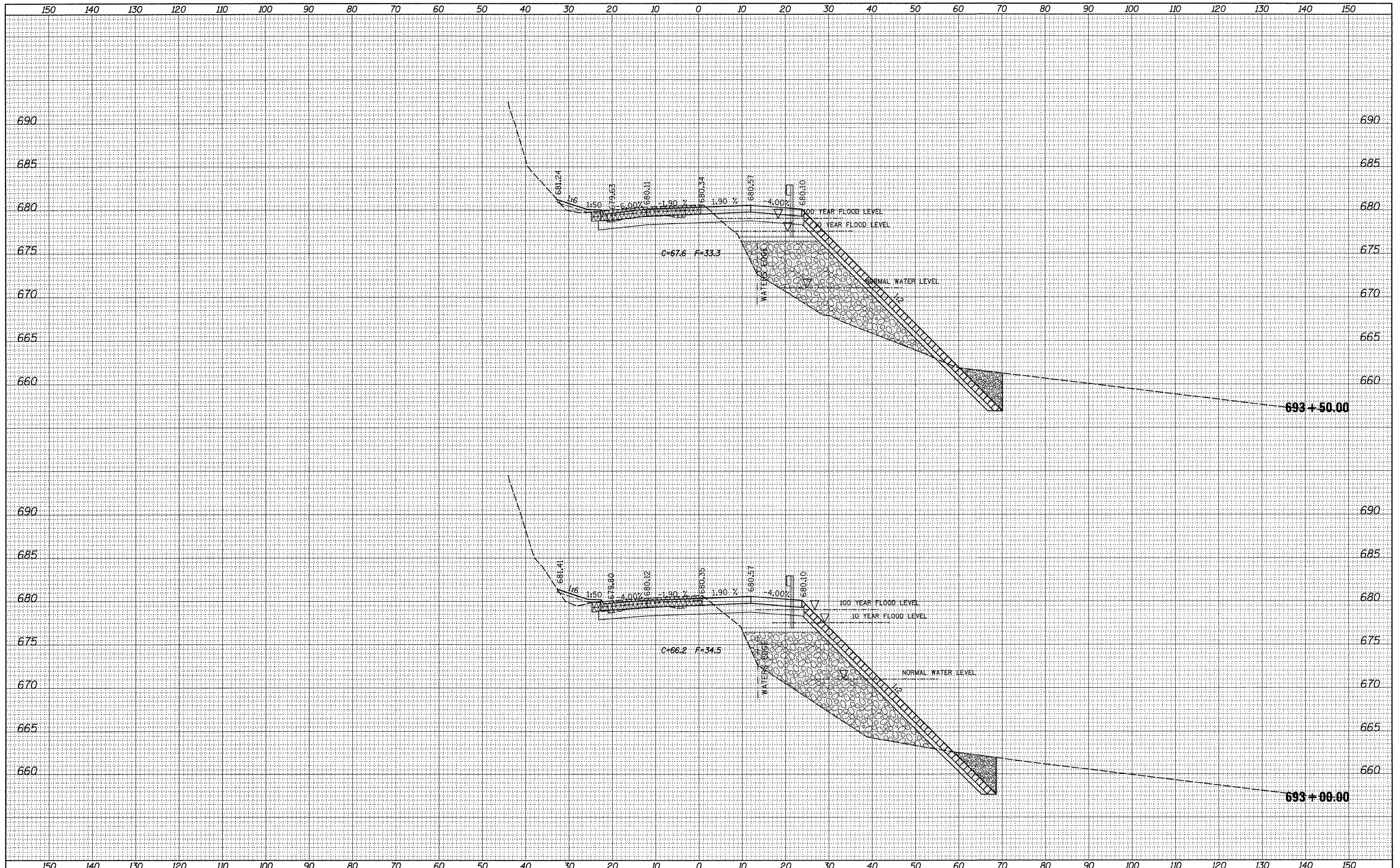

FILE NAME =	USER NAME = grantpm	DESIGNED -	REVISED -	<b>STATE OF ILLINOIS</b> <b>DEPARTMENT OF TRANSPORTATION</b>	<b>IL ROUTE 2</b> <b>CROSS-SECTIONS</b>	F.A.P. RTE.	SECTION	COUNTY	TOTAL SHEETS	SHEET NO.
ca:\pw_work\FWID00T\GRANTPM\dms31213\0206608.xml	td.dgn	DRAWN -	REVISED -			742	37R-4	OGLE	867	496
PLOT SCALE = 10.0000' / IN.	CHECKED -	REVISED -	REVISED -			CONTRACT NO. 64E17				
PLOT DATE = Tue Mar 30 14:02:39 2010	DATE -	REVISED -	REVISED -			SCALE:	SHEET NO. OF SHEETS	STA. 693+00.00 TO STA. 693+50.00	ILLINOIS FED. AID PROJECT	



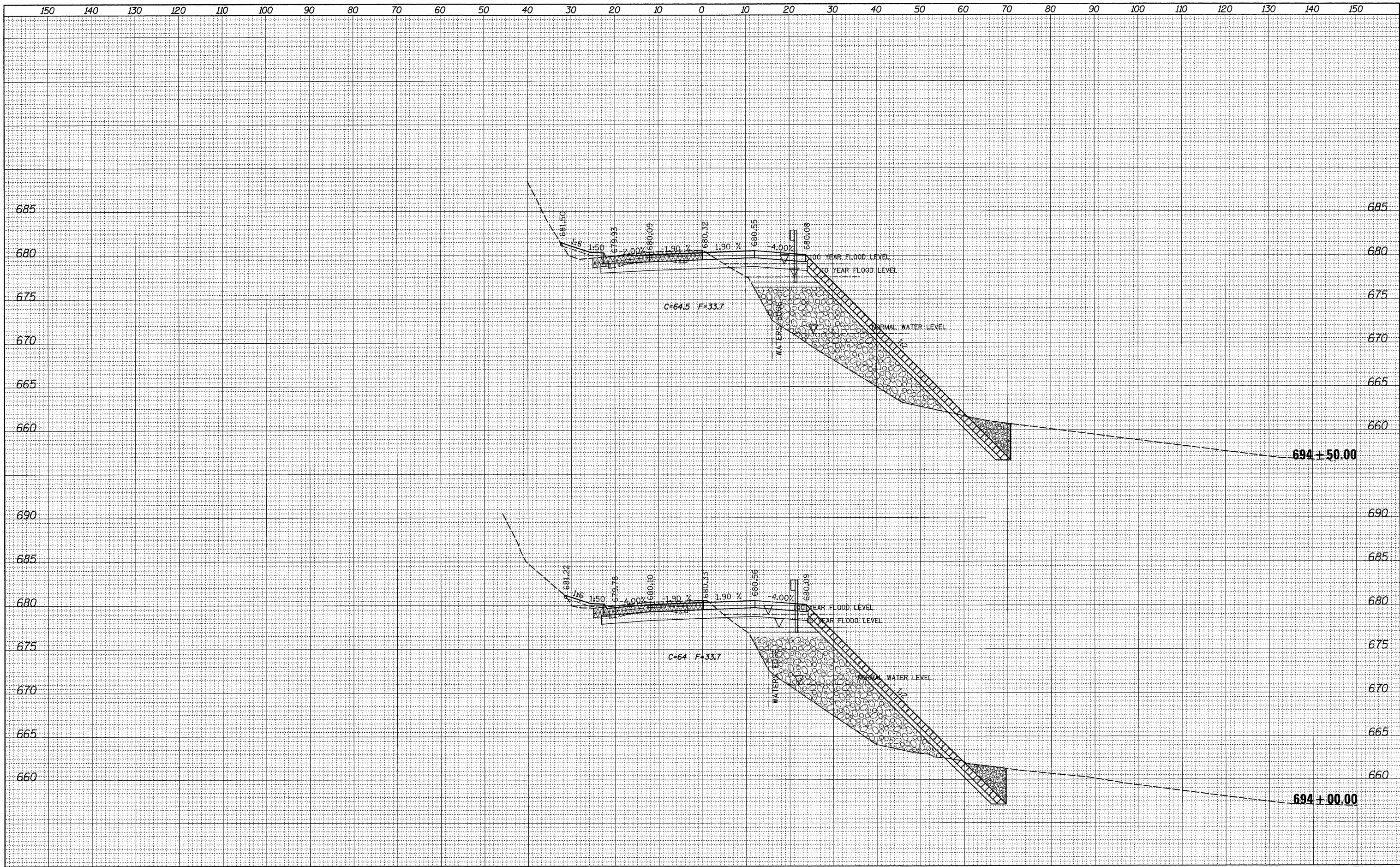

BY	DATE
SURVEYED	
PLOTTED	
TEMPLATE	
NOTE BOOK	
NO.	
AREAS CHECKED	

BY	DATE
SURVEYED	
PLOTTED	
TEMPLATE	
NOTE BOOK	
NO.	
AREAS CHECKED	

FILE NAME =  
 c:\pw\_work\p\WIDOT\GRANTPM\dms31213\0206608xms\1.dgn

USER NAME = grantpm  
 PLOT SCALE = 10.0000' / IN.  
 PLOT DATE = Tue Mar 30 14:02:41 2010

DESIGNED -  
 DRAWN -  
 CHECKED -  
 DATE -

REVISED -  
 REVISED -  
 REVISED -  
 REVISED -

**STATE OF ILLINOIS  
 DEPARTMENT OF TRANSPORTATION**

**IL ROUTE 2  
 CROSS-SECTIONS**

SCALE: SHEET NO. OF SHEETS STA. 694+00.00 TO STA. 694+50.00

F.A.P. RTE. 742	SECTION 37R-4	COUNTY OGLE	TOTAL SHEETS 867	SHEET NO. 497
CONTRACT NO. 64E17			ILLINOIS FED. AID PROJECT	



DATE	
BY	
FINAL SURVEY	
SURVEYED	
PLOTTED	
TEMPLATE	
NOTE BOOK	
AREAS CHECKED	
NO.	

DATE	
BY	
ORIGINAL SURVEY	
SURVEYED	
PLOTTED	
TEMPLATE	
NOTE BOOK	
AREAS CHECKED	
NO.	

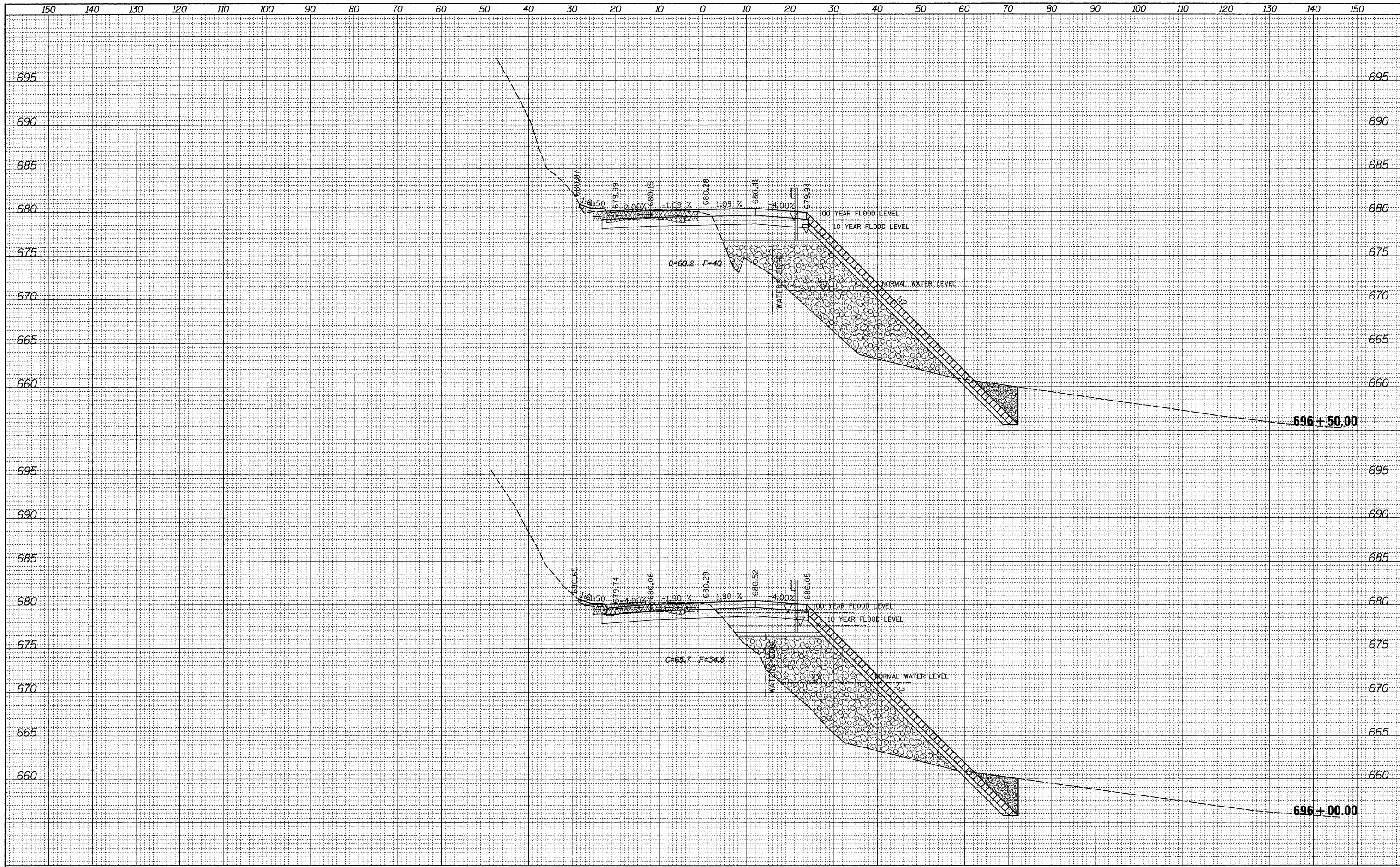

DATE	
BY	
FINAL SURVEY	SURVEYED
NOTE BOOK	PLOTTED
NO.	TEMPLATE
	AREAS CHECKED

DATE	
BY	
ORIGINAL SURVEY	SURVEYED
NOTE BOOK	PLOTTED
NO.	TEMPLATE
	AREAS CHECKED

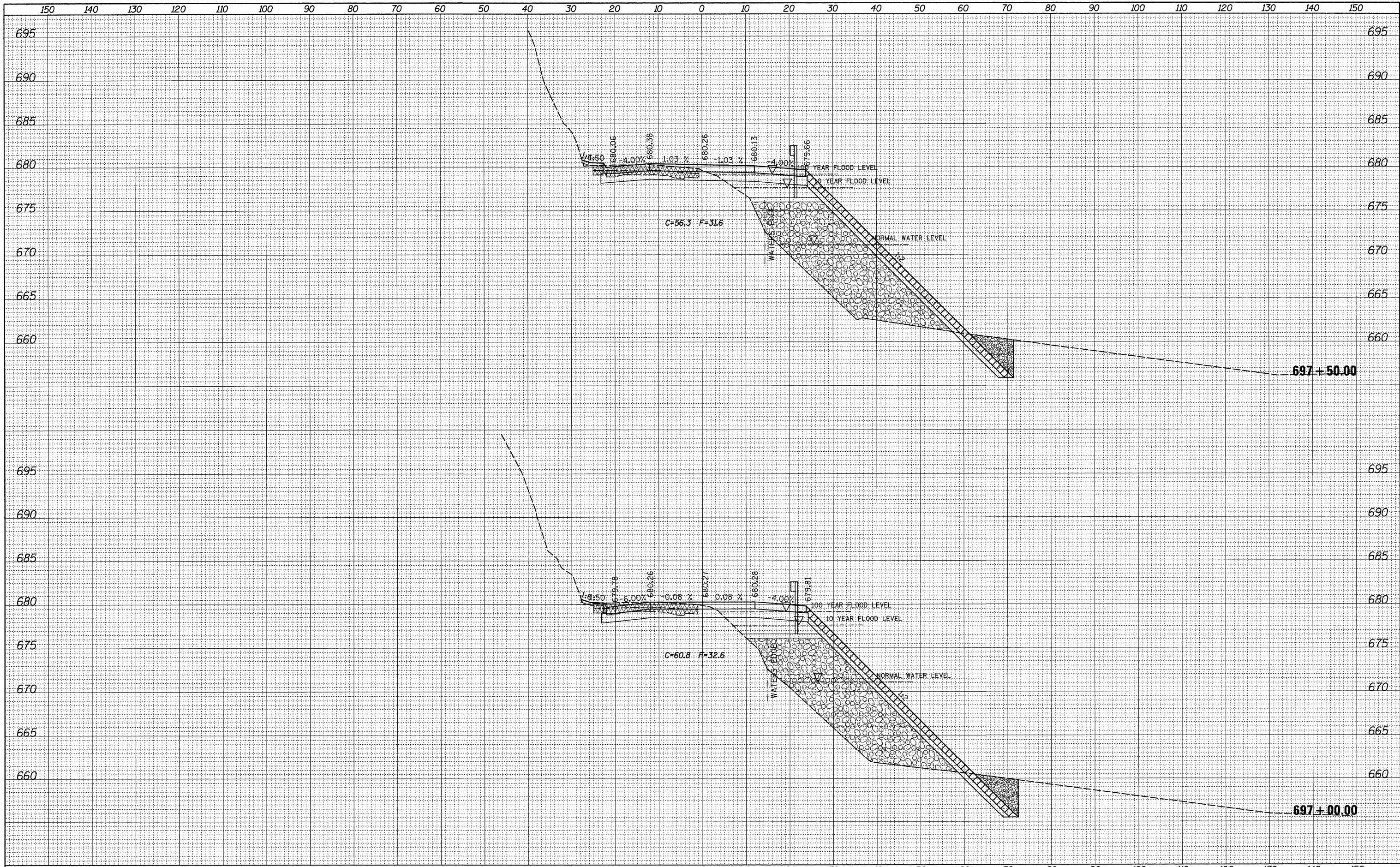

FILE NAME =	USER NAME = grantpm	DESIGNED -	REVISED -	<b>STATE OF ILLINOIS DEPARTMENT OF TRANSPORTATION</b>	<b>IL ROUTE 2 CROSS-SECTIONS</b>			F.A.P. RTE. 742	SECTION 37R-4	COUNTY OGLE	TOTAL SHEETS 867	SHEET NO. 500
cs:\pwwork\pwwid\GRANTPM\dms31213\0206608\msk1.dgn		DRAWN -	REVISED -		SCALE:	SHEET NO.	OF SHEETS	STA. 697+00.00	TO STA. 697+50.00	CONTRACT NO. 64E17	ILLINOIS FED. AID PROJECT	
		CHECKED -	REVISED -									
		DATE -	REVISED -									