

F.A.P. RTE.	SECTION	COUNTY	TOTAL SHEETS	SHEET NO.
315	(22B11-1)	HANCOCK	13	12

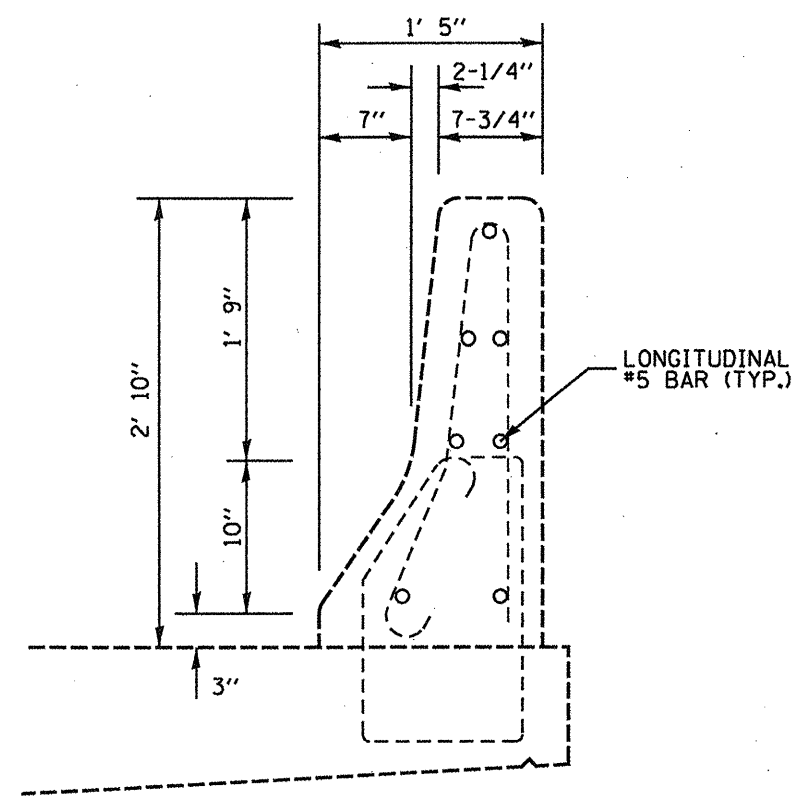

EXISTING EDGE PARAPET
CROSS SECTION W/ REINFORCEMENT

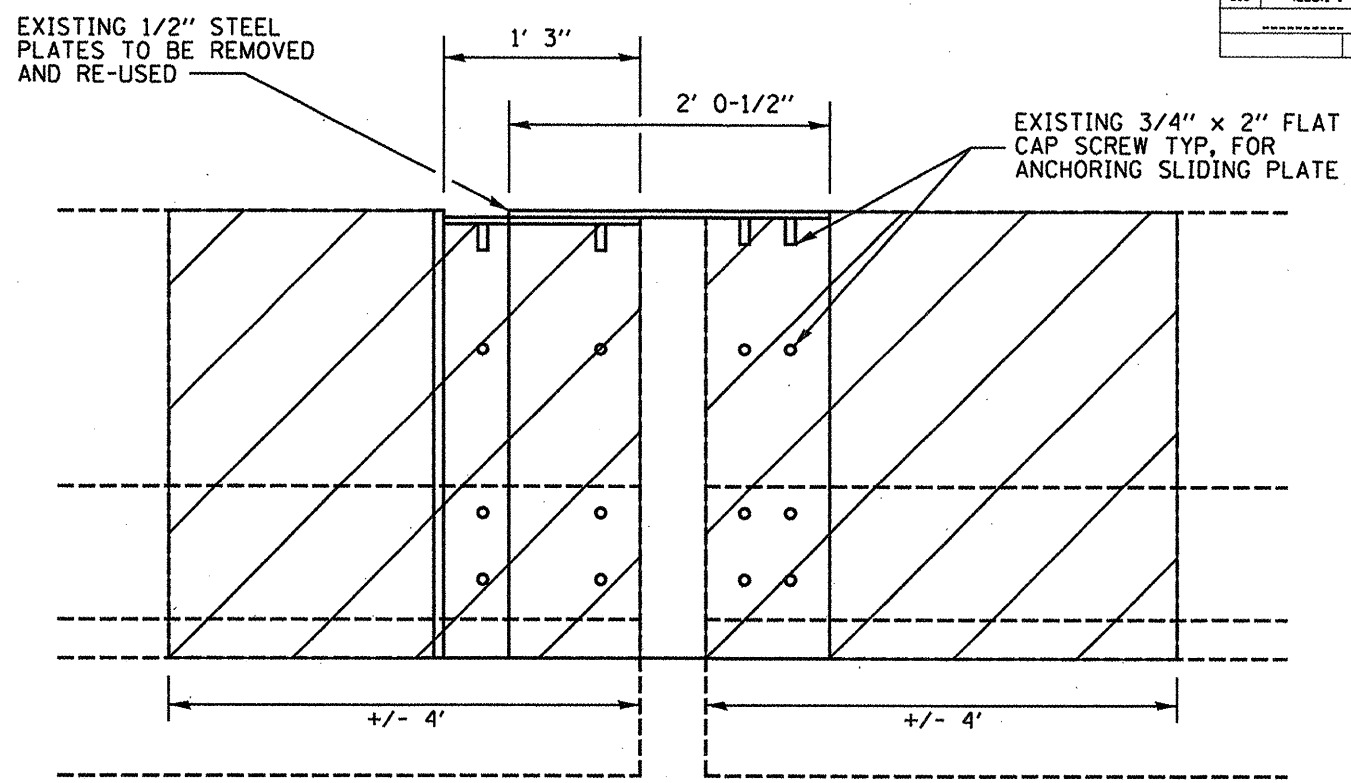

EXISTING TYPICAL PARAPET
ELEVATION VIEW AT EXPANSION JTS.

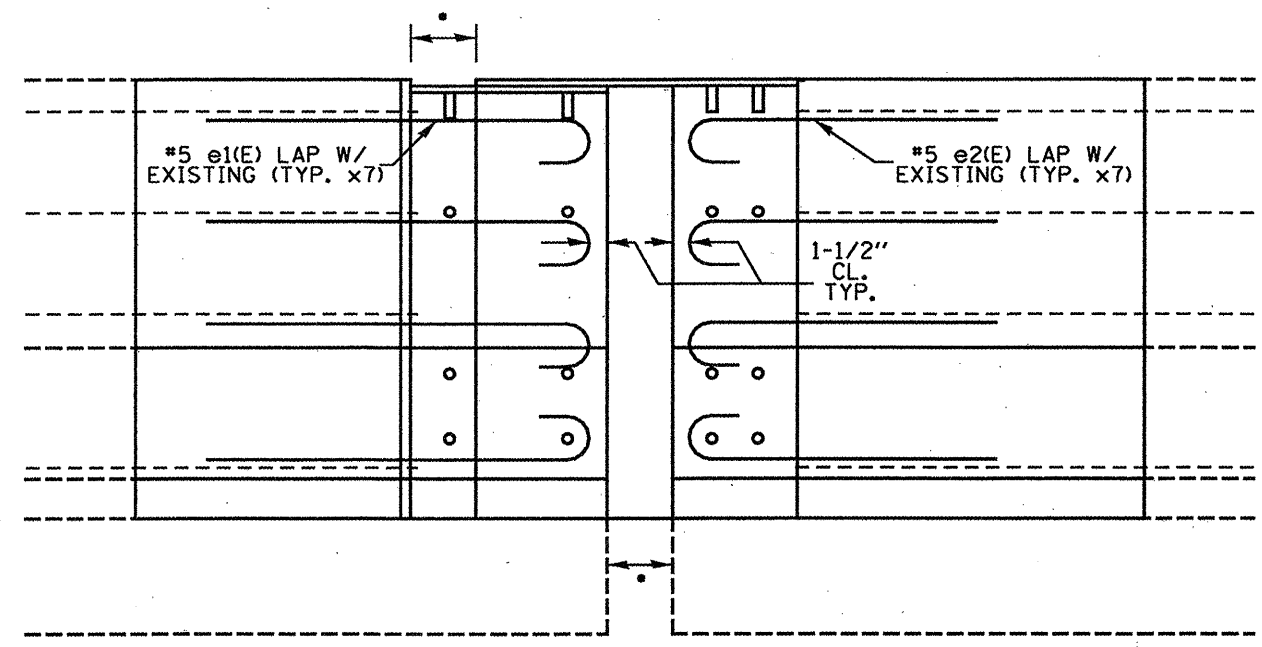

PROPOSED TYPICAL PARAPET
ELEVATION VIEW AT EXPANSION JTS.
(VERTICAL REINFORCEMENT NOT SHOWN)

BILL OF MATERIAL (2 JOINTS)				
BAR	NO.	SIZE	SHAPE	LENGTH
e1(E)	14	5		3' 10"
e2(E)	14	5		3' 5"
REINFORCEMENT BARS (EPOXY COATED)			106 LBS	
CONC. REMOVAL			1.6 CU YD	
CONC. SUPERSTRUCTURE			1.6 CU YD	

NOTES:

ALL EXISTING REINFORCEMENT IS TO REMAIN. ANY DAMAGE TO EXISTING REINFORCEMENT SHALL BE REPAIRED OR REPLACED AT THE CONTRACTOR'S EXPENSE.

ALL PROPOSED REINFORCEMENT SHALL BE LAPPED A MINIMUM OF 2' 2" WITH THE EXISTING REINFORCEMENT. THE PROPOSED REINFORCEMENT MAY BE TRIMMED TO FIT PROVIDED THAT THE MINIMUM LAP LENGTH IS STILL ACHIEVED.

THE SLIDING PLATES SHALL BE RE-ANCHORED WITH NEW 3/4" DIAMETER, 2" LONG FLAT HEAD CAP SCREWS AFTER THE NEW CONCRETE IS POURED. THE EXISTING SCREW HOLES SHALL BE RE-USED. THE CONCRETE INSERTS USED FOR ANCHORING SHALL BE APPROVED BY THE ENGINEER PRIOR TO INSTALLATION. THE COST OF THIS WORK SHALL BE INCLUDED IN THE BID PRICE FOR CONCRETE SUPERSTRUCTURE.

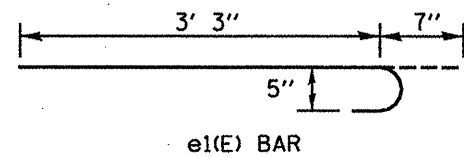

e1(E) BAR

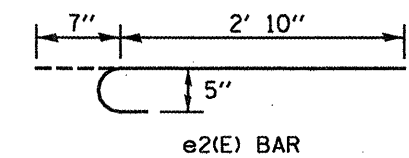

e2(E) BAR

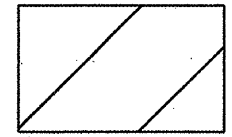

PROPOSED
CONCRETE
REMOVAL

REVISIONS	
NAME	DATE

ILLINOIS DEPARTMENT OF TRANSPORTATION
PARAPET REPAIR DETAILS

FAP 315 (US 136)
SECTION (22B11-1)
HANCOCK COUNTY

• EXPANSION GAP DIMENSION SHALL MATCH THE EXISTING GAP DIMENSION BETWEEN DECK ENDS AT TIME OF CONCRETE POUR.