

STATE OF ILLINOIS
DEPARTMENT OF TRANSPORTATION

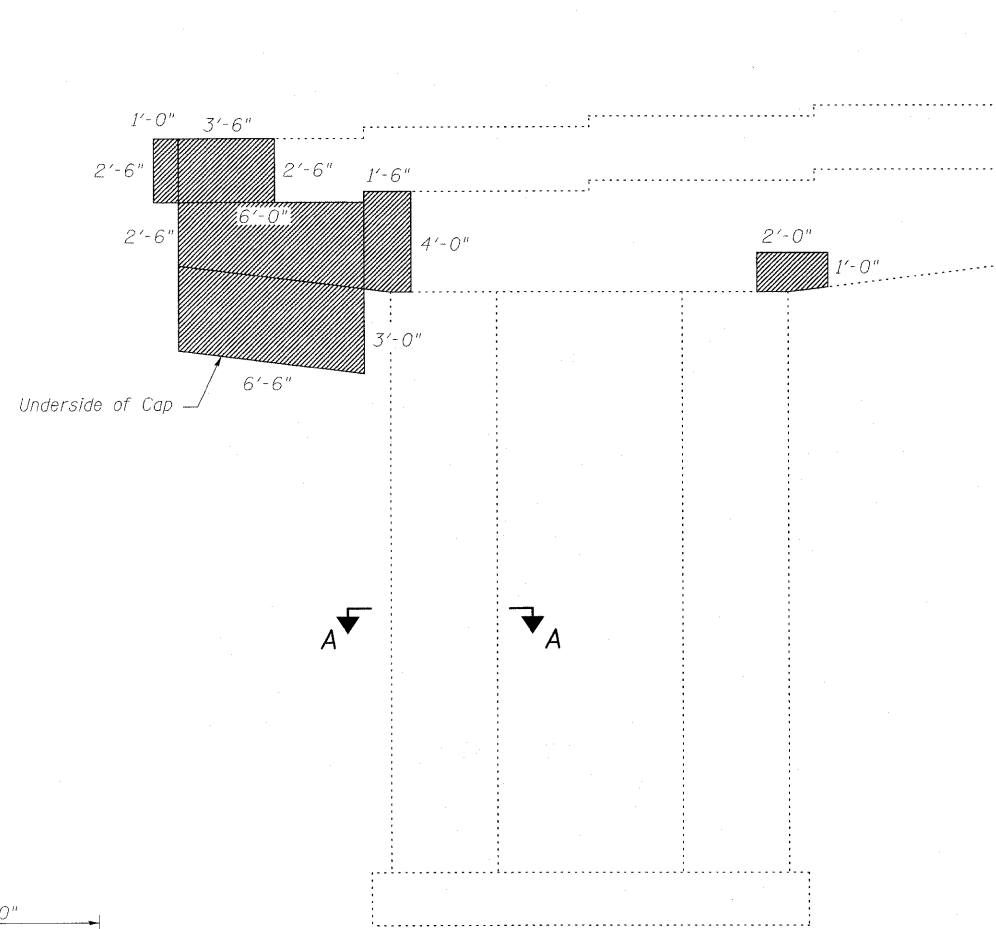

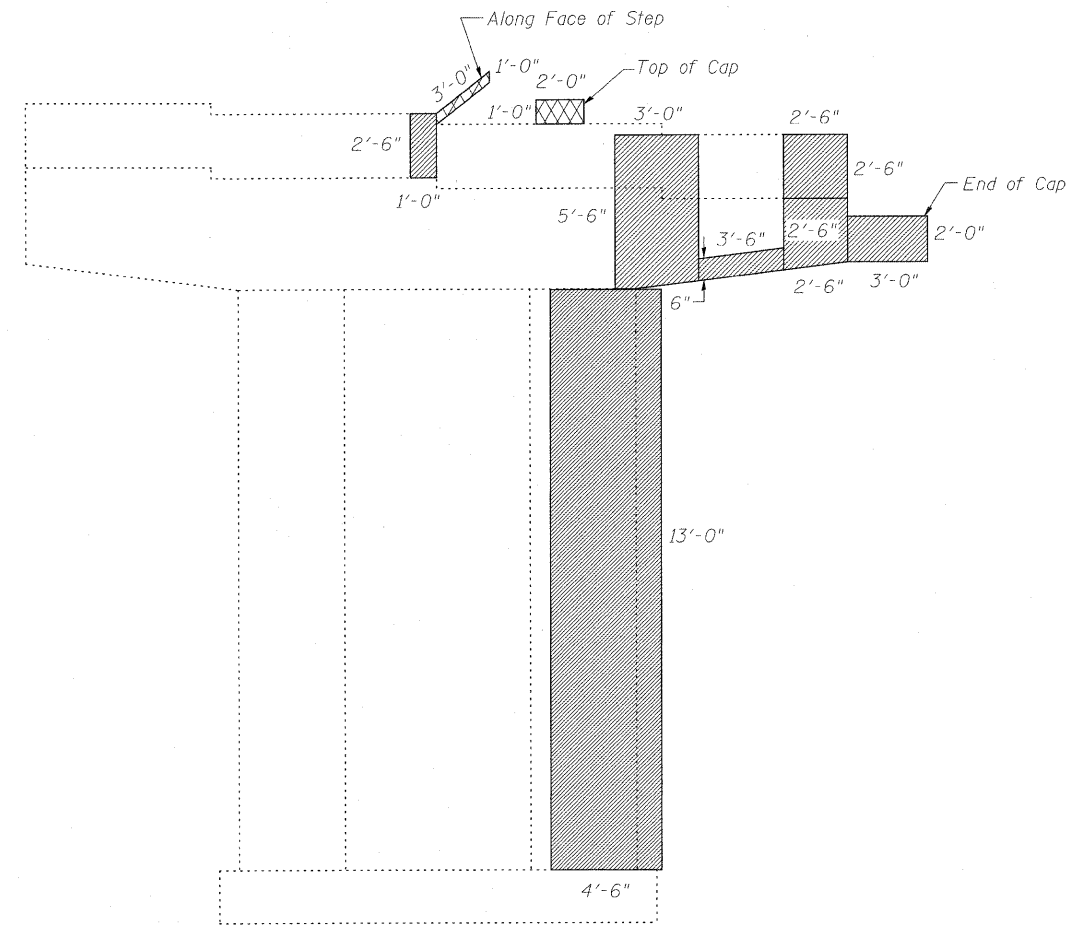

PIER 4
(Looking West)

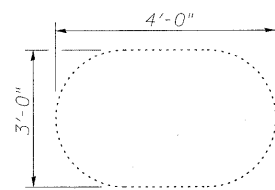

PIER 4
(Looking East)



SECTION A-A
Typical Section
Through Column

 Indicates Unsound Concrete Removal
 Indicates Structural Repair of Concrete

Notes:
Rubbed finish for Structural Repair of Concrete Areas shall be completed according to article 503.15 of the Standard Specifications.

BILL OF MATERIAL

Item	Unit	Total
Structural Repair of Concrete (Depth equal to or less than 5")	Sq. Ft.	152
Rubbed Finish	Sq. Ft.	152
Unsound Concrete Removal	Sq. Yd.	0.6

PIER 4 REPAIR DETAILS
STRUCTURE NO. 025-0018

DESIGNED	B.B.
CHECKED	C.J.F.
DRAWN	W.J.S.
CHECKED	C.J.F. & B.B.



**BERNARDIN
LOCHMUELLER &
ASSOCIATES, INC.**

3 Oak Drive
Maryville, IL 62062-5635
Local (618) 288-4065
Fax 618-288-4996

SHEET NO. 32 36 SHEETS	F.A.I. RTE.	SECTION	COUNTY	TOTAL SHEETS	SHEET NO.
	57	(25-3HB)I-3	EFFINGHAM	1416	1413
SN 025-0018			CONTRACT NO. 74296		
FED. ROAD DIST. NO. 7 ILLINOIS FED. AID PROJECT					