

BM #105  
 Chisled "□" Top of concrete headwall  
 Sta. 231+23, 55' Rt. Elev. 523.09

ROUTE NO.	SECTION	COUNTY	TOTAL SHEETS	SHEET NO.
310	*	MADISON/JERSEY	481	151
F.A.P. RTE.		ILLINOIS		FED. AID PROJECT
310		60-16-1 & 1B, 42-1 & 1B		

SHEET NO. 1 of 1 SHEETS  
 CONTRACT NO. 76318

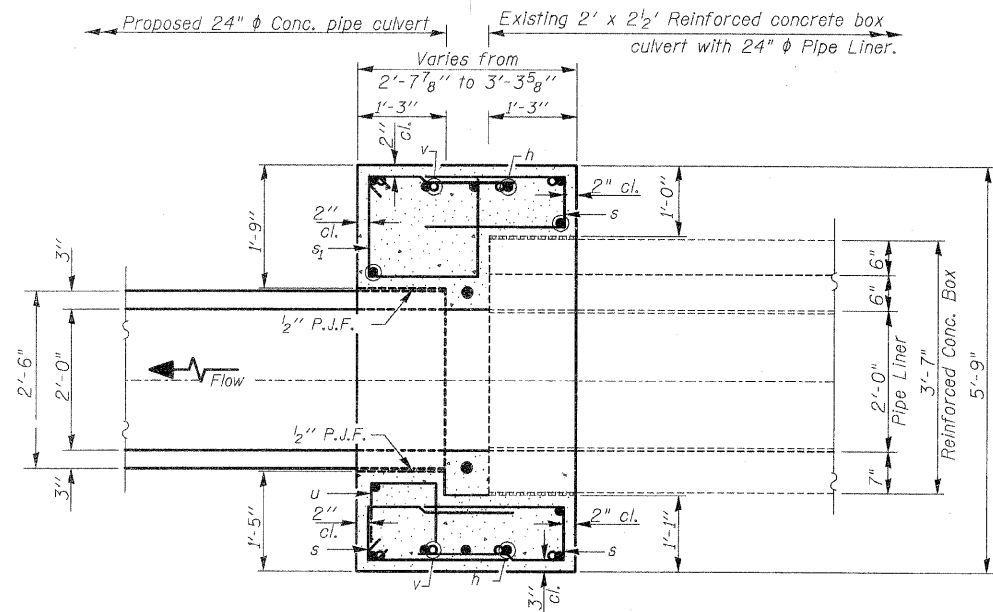

SECTION THRU BOX AT COLLAR  
 SECTION A-A

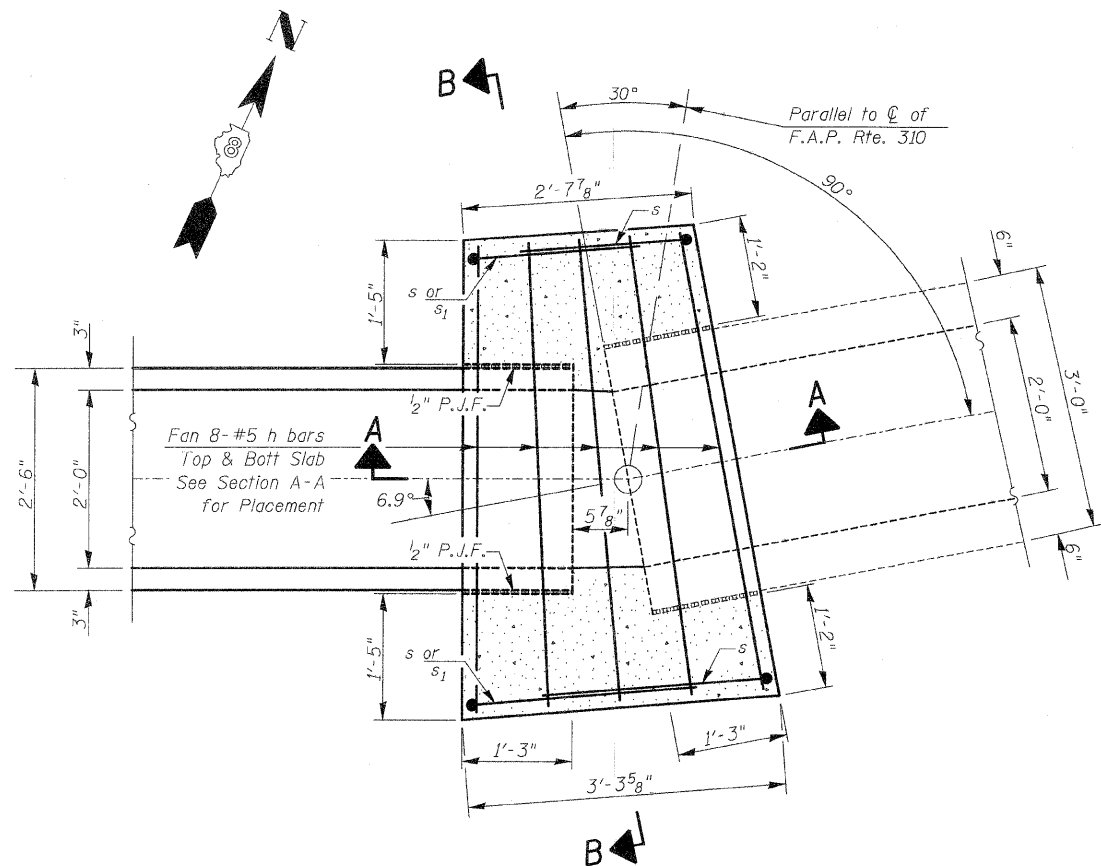

PLAN  
 SHOWING SETTLEMENT COLLAR

DESIGNED	M.E.B.
CHECKED	J.L.G.
DRAWN	M.F.B.
CHECKED	J.L.G.

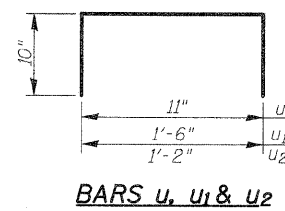

BARS u, u1 & u2

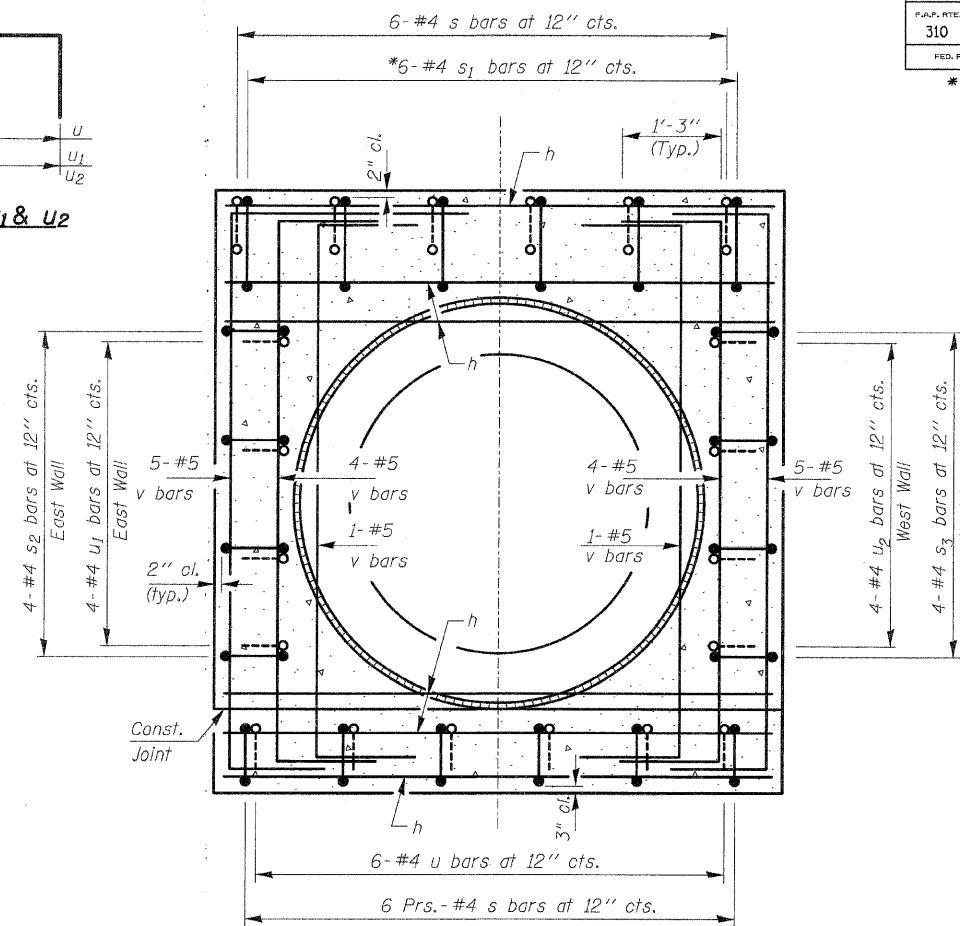

SECTION THRU BOX AT COLLAR  
 SECTION B-B

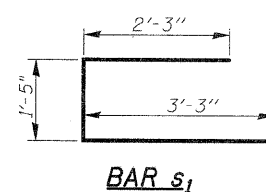

BAR s1

\*Bend & cut s1 bars to fit in field

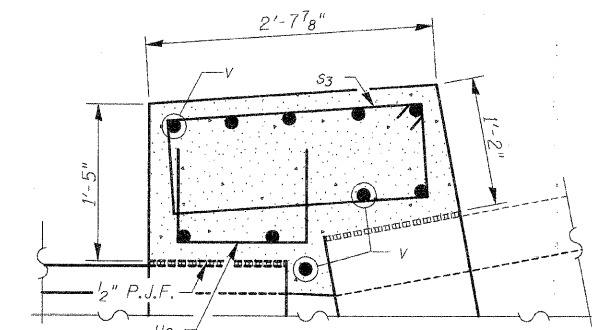

SECTION THRU WEST SIDEWALL

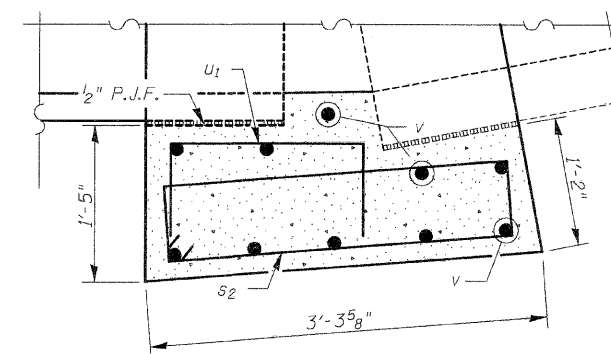

SECTION THRU EAST SIDEWALL

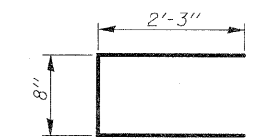

BAR s

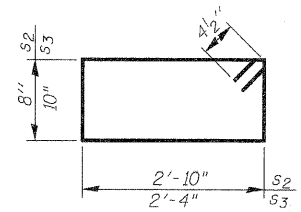

BARS s2 & s3

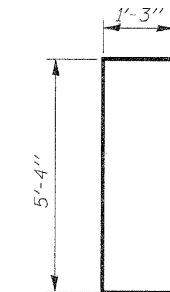

BAR v

BILL OF MATERIAL

Bar	No.	Size	Length	Shape
h	16	#5	5'-0"	—
s	18	#4	5'-2"	┌
s1	6	#4	6'-11"	┌
s2	4	#4	7'-9"	┌
s3	4	#4	7'-1"	┌
u	6	#4	2'-7"	┌
u1	4	#4	3'-2"	┌
u2	4	#4	2'-10"	┌
v	20	#5	7'-10"	┌
Reinforcement Bars			Pound	410
Concrete Collar			Cu. Yd.	2.8

GENERAL NOTES

Reinforcement bars shall conform to the requirements of ASTM A 706 Grade 60.  
 All exposed edges shall be chamfered 3/4" unless otherwise noted.  
 All construction joints shall be bonded.

Plan dimensions and details relative to existing structures have been taken from existing plans and are subject to nominal construction variations. It shall be the Contractor's responsibility to verify such dimensions and details in the field and make necessary approved adjustments prior to ordering materials. Such variations shall not be cause for additional compensation for a change in the scope of the work, however, the Contractor will be paid for the quantity actually furnished at the unit price bid for the work.

DESIGN SPECIFICATIONS

2007 AASHTO LRFD Bridge Design Specifications with 2008 & 2009 Interims

LOADING HL-93

Allow 50#/sq. ft. for future wearing surface.

DESIGN STRESSES

FIELD UNITS

f'c = 3,500 psi  
 fy = 60,000 psi (Reinf.)

2' x 2 1/2' PRECAST CONC. BOX CULVERT

D.S. SETTLEMENT COLLAR DETAILS

F.A.P. RTE. 310 (U.S. RTE. 67)

SECTION 60-16-1 & 1B, 42-1 & 1B

MADISON/JERSEY COUNTY

STATION 232+26.00

**HR**  
 HURST-ROSCHE  
 ENGINEERS, INC.  
 601 NORTH BRUNS LANE  
 SPRINGFIELD, IL 62702  
 (217)-787-1199  
 FAX (217)-793-1199