

STATE OF ILLINOIS  
DEPARTMENT OF TRANSPORTATION

F.A.P. RTE.	SECTION	COUNTY	TOTAL SHEETS	SHEET NO.
71	(113, 112)RS-3	ILLINOIS	8	1
			CONTRACT NO. 66L91	
*FORD & IROQUOIS				

**INDEX OF SHEETS**

- 1 COVER SHEET
- 2 GENERAL NOTES AND COMMITMENTS
- 3 SUMMARY OF QUANTITIES
- 4-5 TYPICAL SECTIONS
- 6 SCHEDULES
- 7-8 DETAILS

**LIST OF ILLINOIS DOT HIGHWAY STANDARDS**

- 000001-08 STANDARD SYMBOLS, ABBREVIATIONS AND PATTERNS
- 001006 DECIMAL OF AN INCH AND OF A FOOT
- 701201-05 LANE CLOSURE, 2L, 2W, DAY ONLY, FOR SPEEDS ≥ 45 MPH
- 701301-04 LANE CLOSURE, 2L, 2W, SHORT TIME OPERATIONS
- 701306-04 LANE CLOSURE, 2L, 2W, SLOW MOVING OPERATIONS DAY ONLY, FOR SPEEDS ≥ 45 MPH
- 701311-03 LANE CLOSURE, 2L, 2W, MOVING OPERATIONS - DAY ONLY
- 701901-08 TRAFFIC CONTROL DEVICES

**PROPOSED  
HIGHWAY PLANS**

**FAP ROUTE 71 (IL 54)  
SECTION (113,112)CJS  
CRACK SEALING  
FORD & IROQUOIS COUNTIES**

C-93-094-21

D-93-059-21

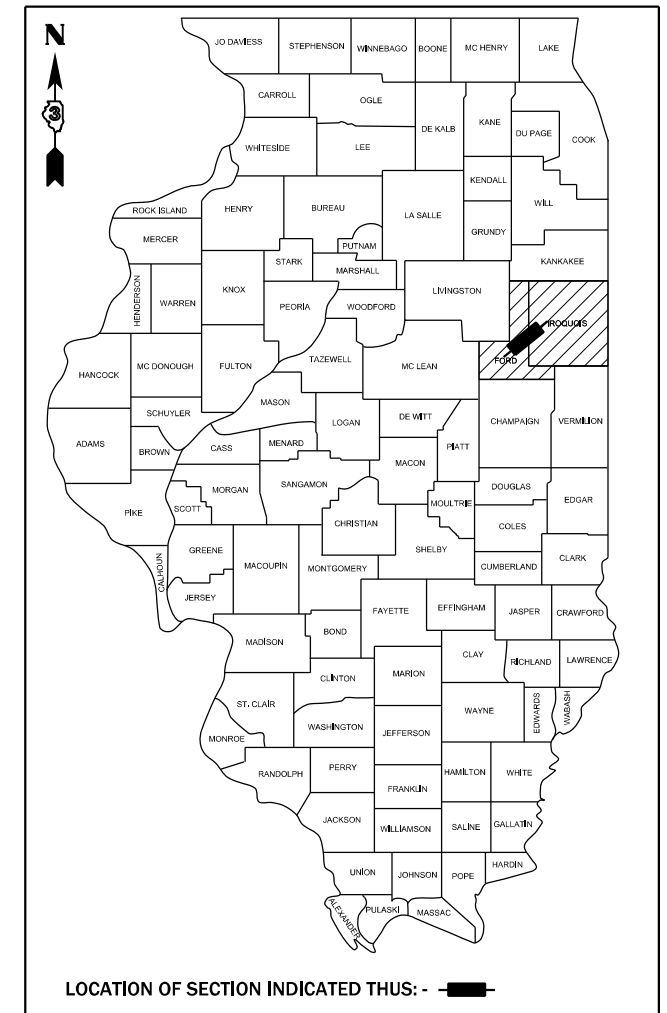

**COUNTY LINE  
STA. 270 + 05**

**BEGINNING OF PROJECT  
STA. 30 + 32**  
PAVEMENT JOINT EAST  
OF IL 115

**END OF PROJECT  
STA. 222 + 42 (SN 038-0213)**  
WEST APPROACH PAVEMENT OF  
SN 038-0213 OVER SPRING CREEK

**MINOR ARTERIAL  
ADT (2019) = 900  
P.V. = 80.0%  
S.U. = 10.0%  
M.U. = 10.0%**

**STATION EQUATION  
363 + 26(BK) = 266 + 80 (AH)**

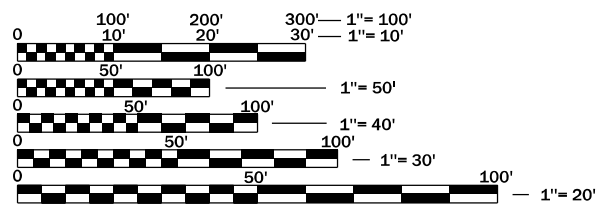

FULL SIZE PLANS HAVE BEEN PREPARED USING STANDARD ENGINEERING SCALES. REDUCED SIZED PLANS WILL NOT CONFORM TO STANDARD SCALES. IN MAKING MEASUREMENTS ON REDUCED PLANS, THE ABOVE SCALES MAY BE USED.

J.U.L.I.E.  
JOINT UTILITY LOCATION INFORMATION FOR EXCAVATION  
1-800-892-0123  
OR 811

**PROJECT ENGINEER: BRAD DUNCAN P.E.  
UNIT CHIEF: LUIS CALDERON P.E.  
DISTRICT 3 NO. (815) 434-6131  
CONTRACT NO. 66L91**

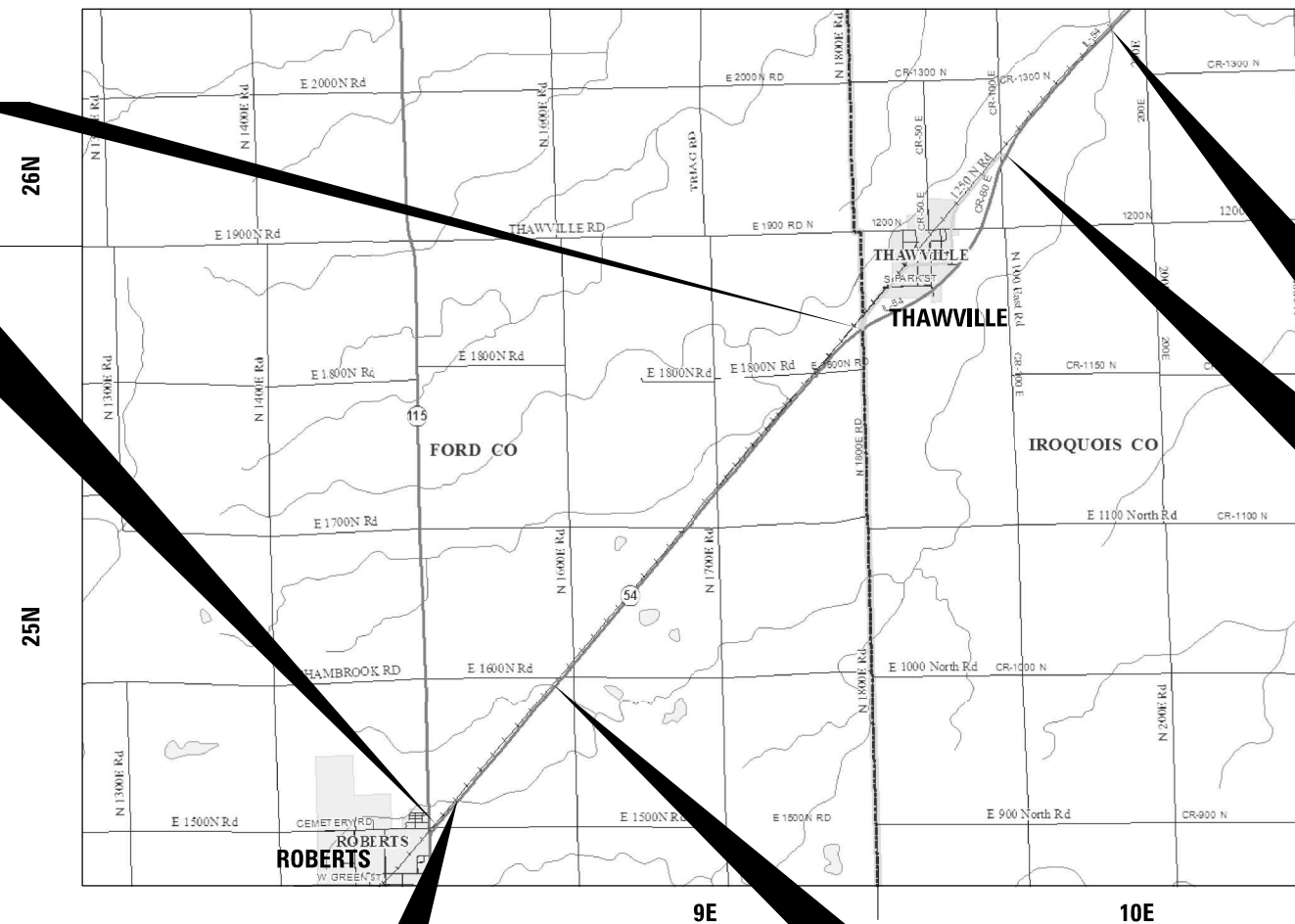

**SN 027-0018  
STA. 46 + 26 TO STA. 46 + 52**

**SN 027-0017  
STA. 98 + 76 TO STA. 99 + 12**

GROSS LENGTH = 37,732 FT. = 7.15 MILE  
NET LENGTH = 37,732 FT. = 7.15 MILE

STATE OF ILLINOIS  
DEPARTMENT OF TRANSPORTATION

SUBMITTED 05-04, 2021  
*Frank Alford*  
REGIONAL ENGINEER

June 25, 2021  
*Scott A. Etk*  
ENGINEER OF DESIGN AND ENVIRONMENT

June 25, 2021  
*James J. Gu*  
DIRECTOR OF HIGHWAYS PROJECT IMPLEMENTATION

**PRINTED BY THE AUTHORITY  
OF THE STATE OF ILLINOIS**

**GENERAL NOTES**

THE INTENT OF THIS PROJECT IS TO ROUTE AND SEAL WORKING TRANSVERSE CRACKS AND PRIMARY LONGITUDINAL CRACKS GREATER THAN 1/4" IN WIDTH. SECONDARY CRACKS GREATER THAN 1/4" IN WIDTH SHALL BE CLEANED AND SEALED.

THE CONTRACTOR SHALL NOT DISTURB THE EXISTING PAVEMENT MARKING OR RAISED REFLECTIVE PAVEMENT MARKERS. THE CONTRACTOR SHALL REPLACE, AT NO ADDITIONAL COST TO THE DEPARTMENT, ANY PAVEMENT MARKING OR RAISED REFLECTIVE PAVEMENT MARKERS DAMAGED BY HIS OPERATION.

THE ENGINEER SHALL DETERMINE WHETHER SECTIONS OF CRACKS SEALING SHOULD BE OMITTED IN ORDER TO AVOID DAMAGING THE PAVEMENT MARKING IN THOSE AREAS.

PLAN DIMENSIONS AND DETAIL RELATIVE TO THE EXISTING PLANS ARE SUBJECT TO ROUTINE VARIATIONS. THE CONTRACTOR SHALL FIELD VERIFY EXISTING DIMENSIONS AND DETAILS AFFECTING NEW CONSTRUCTION OF ORDERING OF MATERIALS. SUCH VARIATIONS SHALL NOT BE CAUSE FOR ADDITIONAL COMPENSATION FOR A CHANGE IN THE SCOPE OF THE WORK. HOWEVER, THE CONTRACTOR WILL BE PAID FOR THE QUANTITY FURNISHED BASED UPON THE UNIT BID PRICE.

ALL PCC BRIDGE DECKS AND PAVEMENT SHALL BE OMITTED. BRIDGE DECKS WITH HMA OVERLAYS ARE TO BE SEALED ONLY (NO ROUTING).

THE FOLLOWING RATE OF APPLICATION HAVE BEEN USED IN CALCULATING PLAN QUANTITIES:

CRACK FILLING	0.52	POUND/FOOT
---------------	------	------------

**COMMITMENTS**

NONE

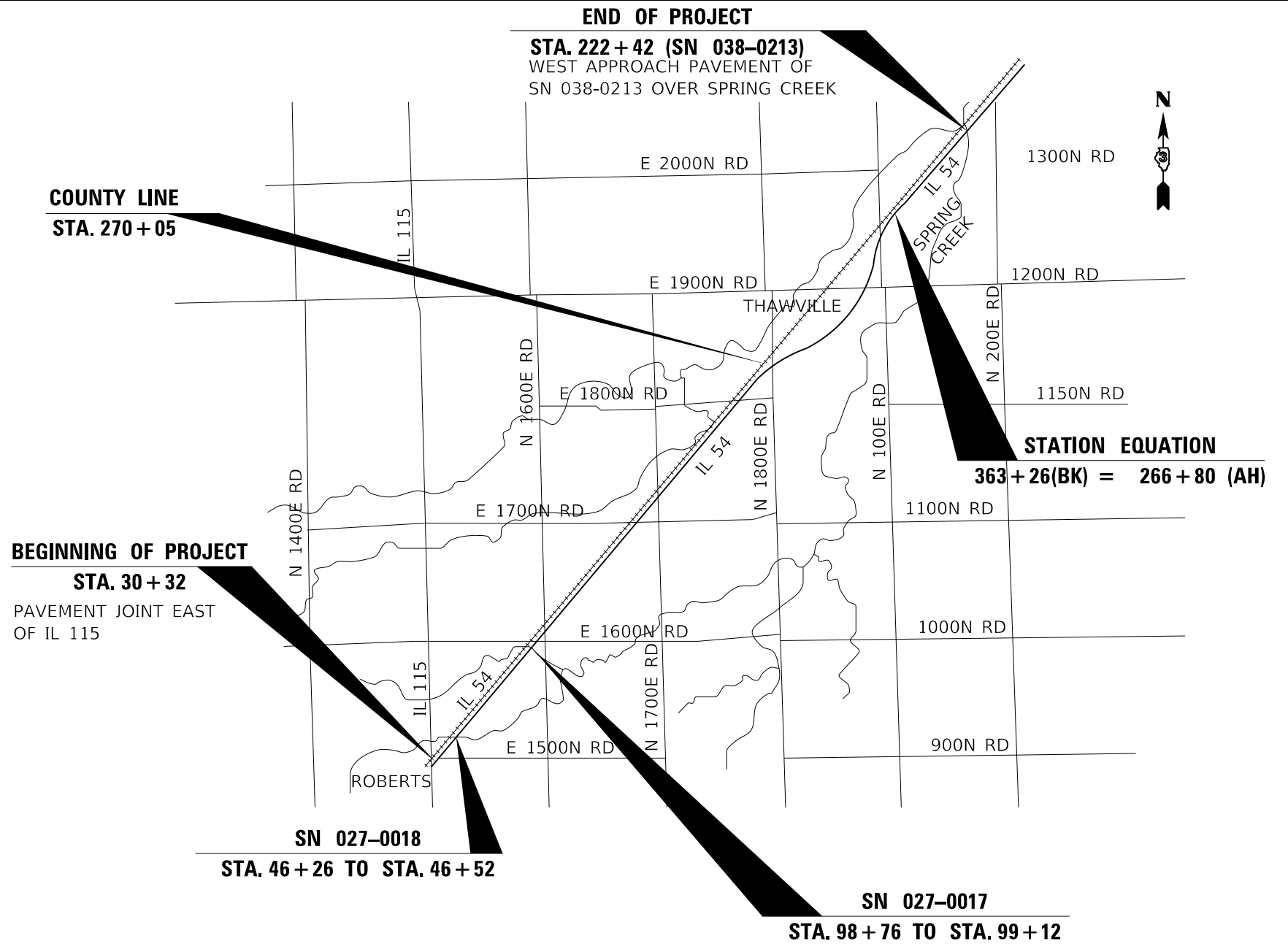

STATE OF ILLINOIS  
 DEPARTMENT OF TRANSPORTATION  
 DISTRICT THREE  
 AS BUILT INFORMATION

STATE OF ILLINOIS  
 DEPARTMENT OF TRANSPORTATION  
 DISTRICT THREE

\_\_\_\_\_  
 SUPERVISING CONSTRUCTION FIELD ENGINEER

PREPARED BY: \_\_\_\_\_  
 DISTRICT STUDIES & PLANS ENGINEER

\_\_\_\_\_  
 RESIDENT ENGINEER / TECHNICIAN

DATE: \_\_\_\_\_

START & END DATES  
 OF CONSTRUCTION: \_\_\_\_\_

EXAMINED BY: \_\_\_\_\_  
 DISTRICT CONSTRUCTION ENGINEER

INSPECTORS: \_\_\_\_\_

\_\_\_\_\_  
 DISTRICT MATERIALS ENGINEER

\_\_\_\_\_  
 DISTRICT OPERATIONS ENGINEER

**STATE OF ILLINOIS**  
**DEPARTMENT OF TRANSPORTATION**

**GENERAL NOTES**  
**& LOCATION MAP**

F.A.P. RTE.	SECTION	COUNTY	TOTAL SHEETS	SHEET NO.
71	(113,112)CJS	-	8	2
CONTRACT NO. 66L91				

SCALE: SHEET 1 OF 1 SHEETS STA. TO STA.

ILLINOIS FED. AID PROJECT

\*FORD & IROQUOIS

MODEL: Default  
 FILE NAME: p:\pubplanroom\dtd\111313038-0213\DOT\Documents\DOT\_Offices\District\_3\Projects\03866L91\CADD\03866L91-113-cover.dgn

CODE NO.	ITEM	UNIT	TOTAL QUANTITY	CONSTRUCTION CODE	
				100% STATE	
				STATE FORD ROADWAY	STATE IROQUOIS ROADWAY
				0005 RURAL	0005 RURAL
45100100	CRACK ROUTING (PAVEMENT)	FOOT	16582	12269	4313
45100200	CRACK FILLING	POUND	8624	6381	2243
67100100	MOBILIZATION	L SUM	1	0.6	0.4
70100450	TRAFFIC CONTROL AND PROTECTION, STANDARD 701201	L SUM	1	0.6	0.4
70100460	TRAFFIC CONTROL AND PROTECTION, STANDARD 701306	L SUM	1	0.6	0.4
Z0030850	TEMPORARY INFORMATION SIGNING	SQ FT	42	21	21

\* SPECIALTY ITEM

MODEL: Default  
FILE NAME: P:\pub\barcom.mxd Illinois\apps\PWIDOT\Documents\DOT\_Offices\District 3\Projects\D366L91\CADD\DATA\D366L91-Sub-500.dgn

<table border="1"> <tr> <td>USER NAME = ZAGARIK</td> <td>DESIGNED -</td> <td>REVISED -</td> </tr> <tr> <td>PLOT SCALE = 100.0000 ' / in.</td> <td>CHECKED -</td> <td>REVISED -</td> </tr> <tr> <td>PLOT DATE = 5/3/2021</td> <td>DATE -</td> <td>REVISED -</td> </tr> </table>	USER NAME = ZAGARIK	DESIGNED -	REVISED -	PLOT SCALE = 100.0000 ' / in.	CHECKED -	REVISED -	PLOT DATE = 5/3/2021	DATE -	REVISED -	<p style="text-align: center;"><b>STATE OF ILLINOIS DEPARTMENT OF TRANSPORTATION</b></p>	<p style="text-align: center;"><b>SUMMARY OF QUANTITIES</b></p>	<table border="1"> <tr> <th>F.A.P. RTE.</th> <th>SECTION</th> <th>COUNTY</th> <th>TOTAL SHEETS</th> <th>SHEET NO.</th> </tr> <tr> <td>71</td> <td>(113,112)CJS</td> <td>-</td> <td>8</td> <td>3</td> </tr> </table>	F.A.P. RTE.	SECTION	COUNTY	TOTAL SHEETS	SHEET NO.	71	(113,112)CJS	-	8	3	<p style="text-align: center;">CONTRACT NO. 66L91</p>
USER NAME = ZAGARIK	DESIGNED -	REVISED -																					
PLOT SCALE = 100.0000 ' / in.	CHECKED -	REVISED -																					
PLOT DATE = 5/3/2021	DATE -	REVISED -																					
F.A.P. RTE.	SECTION	COUNTY	TOTAL SHEETS	SHEET NO.																			
71	(113,112)CJS	-	8	3																			
SCALE:	SHEET 1 OF 1 SHEETS	STA.	TO STA.																				
		ILLINOIS FED. AID PROJECT																					

\*FORD & IROQUOIS  
REV. 5/21/21

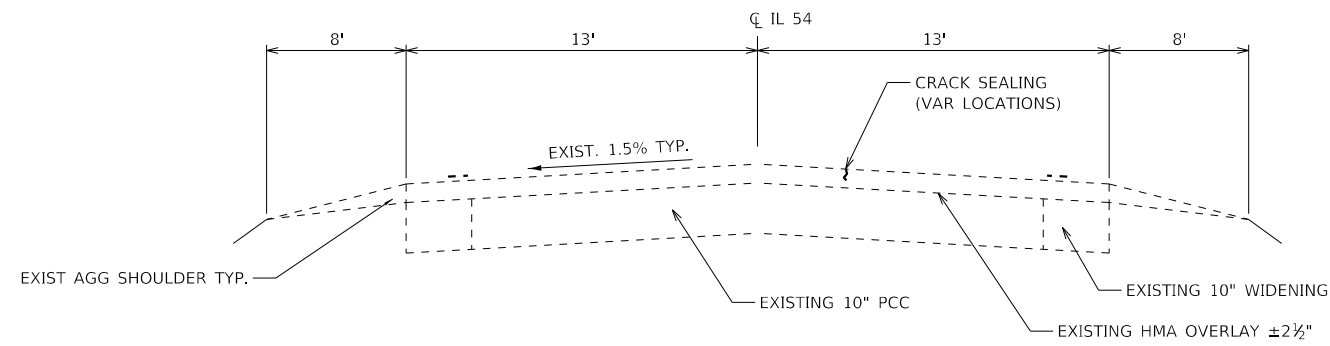

**TYPICAL SECTION 1**

STA. 30+32 TO STA. 46+26  
 STA. 46+52 TO STA. 98+76  
 STA. 99+12 TO STA. 249+79

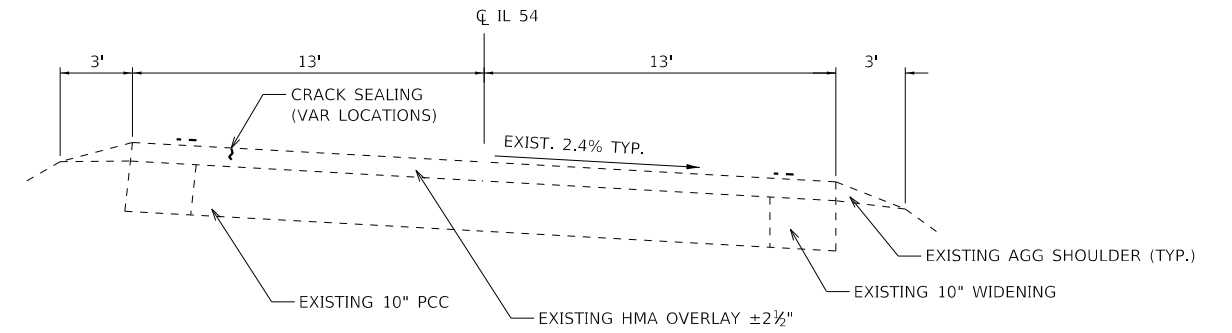

**TYPICAL SECTION 3**

STA. 249+79 TO STA. 275+79  
 STA. 337+62 TO STA. 363+26(BK)

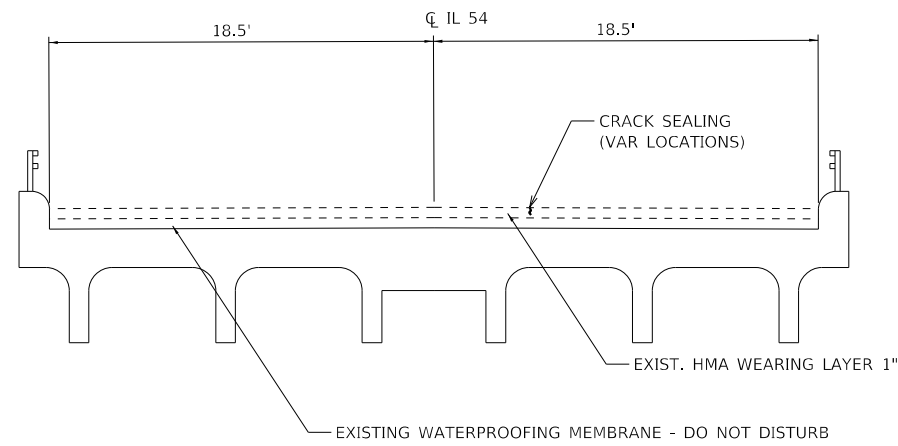

**TYPICAL SECTION 2**

STA. 46+26 TO STA. 46+52  
 STA. 98+76 TO STA. 99+12

**NOTE: DO NOT DISTURB EXISTING WATERPROOFING MEMBRANE**

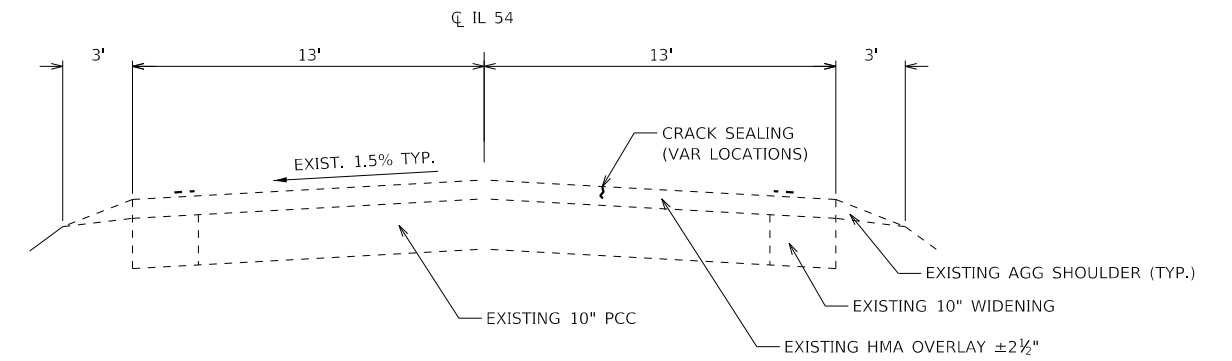

**TYPICAL SECTION 4**

STA. 275+79 TO STA. 280+16  
 STA. 331+43 TO STA. 337+62

**STATION EQUATION: 363 + 26(BK) = 266 + 80(AH)**

MODEL: Default  
 FILE NAME: p:\pub\lancorn.mxd  
 PROJECT: I:\CD\DOT\Documents\DOT - Offices\District 3\Projects\0366L91\113-112\CJIS\113-112\CJIS.dgn

USER NAME = ZAGARIK	DESIGNED -	REVISED -
	DRAWN -	REVISED -
PLOT SCALE = 100,0000' / in.	CHECKED -	REVISED -
PLOT DATE = 5/3/2021	DATE -	REVISED -

**STATE OF ILLINOIS  
 DEPARTMENT OF TRANSPORTATION**

**TYPICAL SECTIONS**

SCALE: SHEET 1 OF 2 SHEETS STA. TO STA.

F.A.P. RTE.	SECTION	COUNTY	TOTAL SHEETS	SHEET NO.
71	(113,112)CJIS	-	8	4
CONTRACT NO. 66L91				
ILLINOIS FED. AID PROJECT				

\*FORD & IROQUOIS

FOR INFORMATION ONLY

EXISTING CURVE DATA FROM OLD PLANS						
PC	PI	PT	Δ	D	R	S
249+79.4	263+02.2	275+79.4	26°-00"	1°-00"	5730'	2.4%
280+16.1	307+65.4	331+42.8	51°-16'	1°-00"	5730'	2.4%
337+61.5	350+45.7	362+88.2	25°-16'	1°-00"	5730'	2.4%

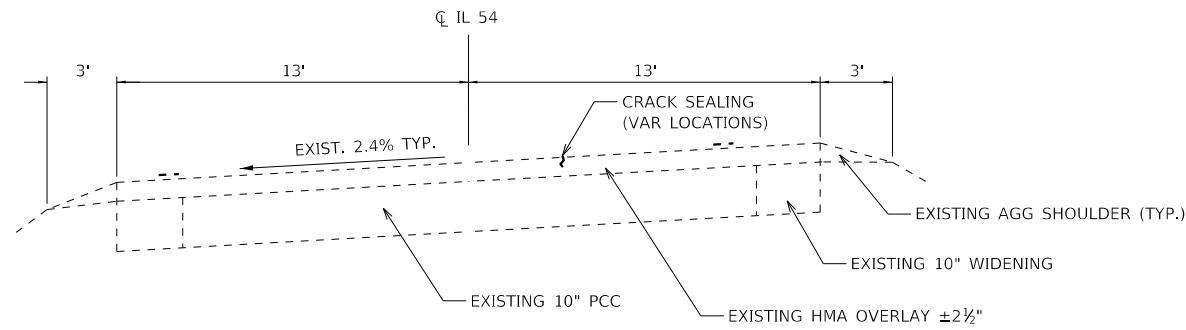

**TYPICAL SECTION 5**  
STA. 280+16 TO STA. 331+43

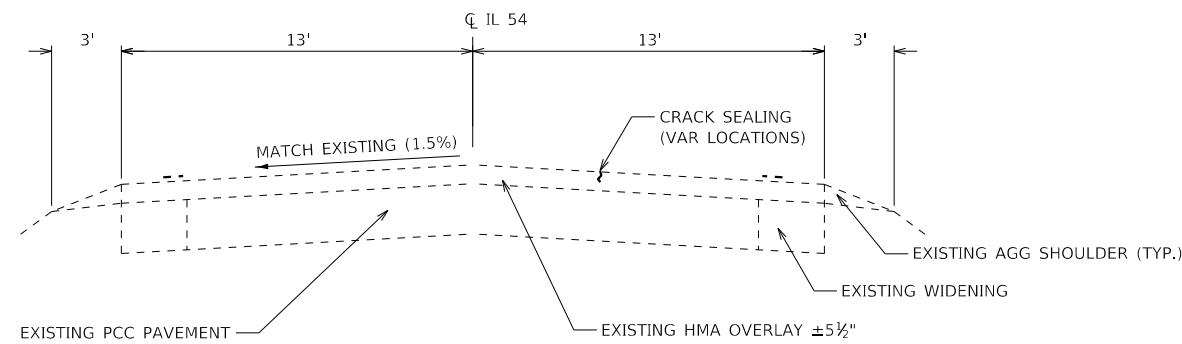

**TYPICAL SECTION 6**  
STA. 266+80(AH) TO STA. 222+42

STATION EQUATION: 363 + 26(BK) = 266 + 80(AH)

MODEL: Default  
 FILE NAME: p:\pub\lancom\dat\illinois\pwr\DOT\Documents\DOT Offices\District 3\Projects\0366L91\CADD\0366L91-1-shc-yp\scale.dgn

USER NAME = ZAGARIK	DESIGNED -	REVISED -
	DRAWN -	REVISED -
PLOT SCALE = 100.0000' / in.	CHECKED -	REVISED -
PLOT DATE = 5/3/2021	DATE -	REVISED -

STATE OF ILLINOIS  
DEPARTMENT OF TRANSPORTATION

TYPICAL SECTIONS

SCALE: SHEET 2 OF 2 SHEETS STA. TO STA.

F.A.P. RTE.	SECTION	COUNTY	TOTAL SHEETS	SHEET NO.
71	(113,112)CIS	-	8	5
CONTRACT NO. 66L91				
ILLINOIS FED. AID PROJECT				

\*FORD & IROQUOIS

CRACK ROUTING AND SEALING SCHEDULE								
LOCATION			DESCRIPTION	LENGTH	TRAVERSE CRACK ROUTING (PAVEMENT)	LONGITUDINAL CRACK ROUTING (PAVEMENT)	TRANSVERSE CRACK FILLING	LONGITUDINAL CRACK FILLING
STA	TO	STA		FOOT	FOOT	FOOT	POUND	POUND
FORD COUNTY								
30+32	TO	46+39	BEGINNING OF PROJECT TO SN 027-0018	1,607	676	20	352	10
46+39	TO	98+94	SN 027-0018 TO SN 027-0017	5,255	2,444	30	1,271	16
98+94	TO	102+05	SN 027-0017 TO E 1600 N RD	311	156	0	81	0
102+05	TO	107+72	E 1600 N RD TO N 1600 E RD	567	338	0	176	0
107+72	TO	171+32	N 1600 E RD TO E 1700 N RD	6,360	3,328	435	1,731	226
171+32	TO	187+85	E 1700 N RD TO N 1700 E RD	1,653	806	0	419	0
187+85	TO	243+40	N 1700 E RD TO E 1800 N RD	5,555	2,184	0	1,136	0
243+40	TO	265+70	E 1800 N RD TO N 1800 E RD	2,230	962	890	500	463
<b>FORD COUNTY SUBTOTAL</b>				<b>23,538</b>		<b>12,269</b>		<b>6,381</b>
IROQUOIS COUNTY								
265+70	TO	293+96	N 1800 E RD TO WOOD ST	2,826	1,092	3	568	2
293+96	TO	307+16	WOOD ST TO SOUTH ST	1,320	702	0	365	0
307+16	TO	322+02	SOUTH ST TO E 1200 N RD	1,486	624	0	324	0
322+02	TO	345+62	E 1200 N RD TO N 100 E RD	2,360	884	0	460	0
345+62	TO	363+26	N 100 E RD TO STA. EQ.	1,764		10	514	5
STA EQUATION: 363+26(BK) = 266+80(AH)					988		0	0
266+80	TO	222+42	STA. EQ. TO END OF PROJECT	4,438		10	0	5
<b>IROQUOIS COUNTY SUBTOTAL</b>				<b>14,194</b>		<b>4,313</b>		<b>2,243</b>
<b>PROJECT TOTAL</b>				<b>37,732</b>		<b>16,582</b>		<b>8,624</b>

NOTE: PREFERENCE SHALL BE GIVEN TO THE TRANSVERSE CRACK FILLING

PERMANENT SURVEY MARKER TABLE					
MONUMENT NUMBER	DESCRIPTION	EXISTING MONUMENT TYPE	PROPOSED MONUMENT TYPE	MONUMENT RECORD TO BE RECORDED	RESPONSIBILITY
N/A	NO PERMANENT SURVEY MARKERS OR SECTION CORNER MARKERS TO BE SET ON THIS JOB	N/A	N/A	N/A	N/A

NO KNOWN LAND SURVEY OR CENTERLINE CONTROL MONUMENTS ARE ON THE ROAD SURFACE THAT WILL BE DISTURBED BY THE CRACK AND JOINT SEALING. UNKNOWN MONUMENTS SET BY OTHERS MAY EXIST. IF FOUND, R.E. WILL REQUEST A PLATS AND PLANS SURVEYOR TO GPS THE MONUMENT AND RESET IT IN KIND FOLLOWING CONSTRUCTION. NO MONUMENT RECORDS ARE REQUIRED FOR THIS JOB.

MOE:\1 - Default FILE NAME: p:\pub\barcom.mxd FILE: \\barcom.mxd I:\projects\DOT\Documents\DOT\Office\District\_3\Projects\0366\01\CADD\0366\_01\_sch\Schedule.dgn

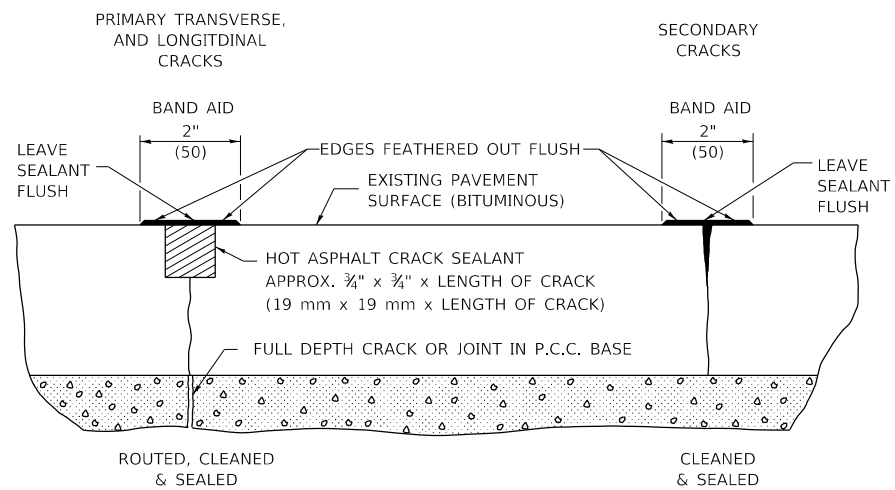

**CRACK SEALING HMA PAVEMENT DETAIL**

MODEL: Default  
 FILE NAME: p:\p\planroom\dat\illinois\p\WIDOT\Documents\DOT\_Offices\District\_3\Projects\0366L91\CADD\0366L91\_sht-crack-seal.dgn

USER NAME = ZAGARIK	DESIGNED -	REVISED -
	DRAWN -	REVISED -
PLOT SCALE = 100.0000' / in.	CHECKED -	REVISED -
PLOT DATE = 5/3/2021	DATE -	REVISED -

**STATE OF ILLINOIS  
DEPARTMENT OF TRANSPORTATION**

**DETAILS**

SCALE: SHEET 1 OF 2 SHEETS STA. TO STA.

F.A.P. RTE.	SECTION	COUNTY	TOTAL SHEETS	SHEET NO.
71	(113,112)CJS	-	8	7
CONTRACT NO. 66L91			ILLINOIS FED. AID PROJECT	

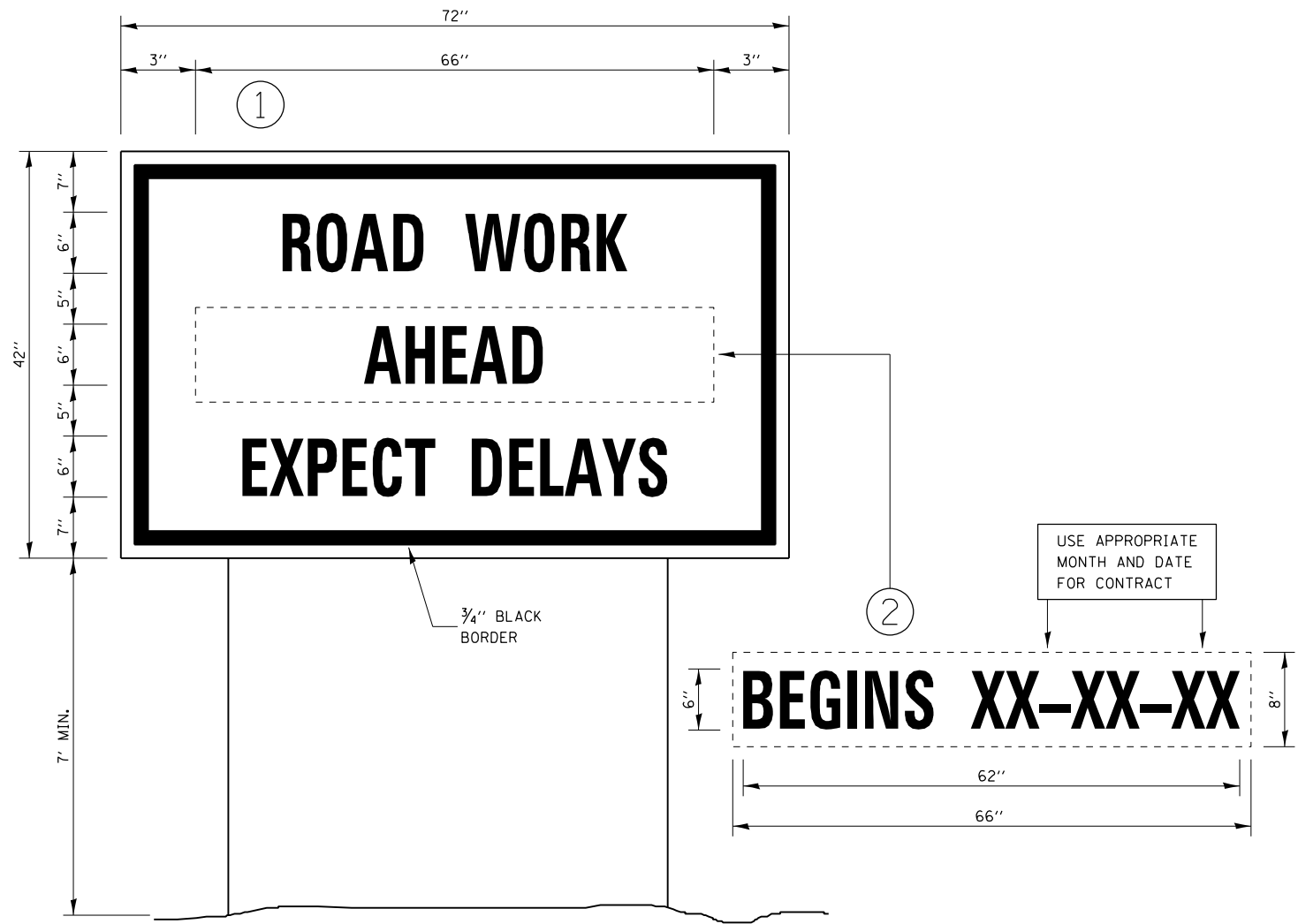

**TEMPORARY INFORMATION SIGNING**

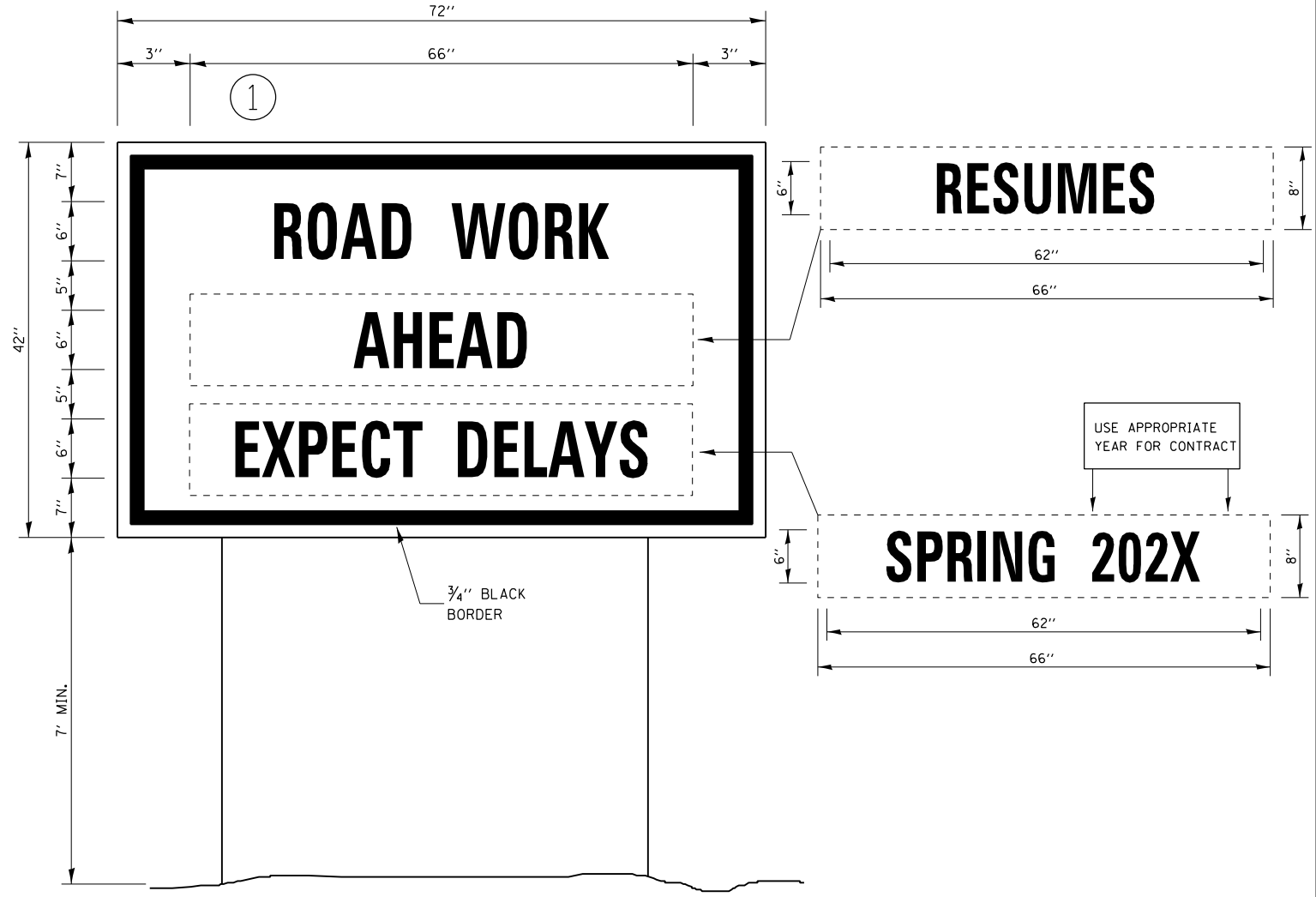

**WINTER SHUT DOWN SIGNING**

**NOTES:**

1. USE 6" D BLACK LETTERING ON FLOURESENT ORANGE BACKGROUND.
2. ERECT SIGNS AT LOCATIONS IN ADVANCE OF THE "ROAD CONSTRUCTION AHEAD" SIGNS AS DIRECTED BY THE ENGINEER.
3. ERECT SIGN ① WITH INSTALLED PANEL ② A MINIMUM OF ONE WEEK PRIOR TO THE START OF THE LANE CLOSURE.
4. REMOVE PANEL ② ON THAT DATE.
5. SEE SPECIAL PROVISION "TEMPORARY INFORMATION SIGNING" FOR ADDITIONAL INFORMATION.
6. WILL BE PAID FOR PER SQ FT AS "TEMPORARY INFORMATION SIGNING". EACH SIGN = 21 SQ FT AND THE DATE PANEL ② WILL NOT BE MEASURED SEPARATELY FOR PAYMENT.

MODEL: Default  
 FILE: Model: p:\pub\lanroom\mod\illinois\p\w\DOT\Documents\DOT - Offices\District 3\Projects\03666\91\CADD\03666\_91\_sht-0666.dgn

USER NAME = ZAGARIK	DESIGNED -	REVISED -
PLOT SCALE = 100,0000' / in.	DRAWN -	REVISED -
PLOT DATE = 5/3/2021	CHECKED -	REVISED -
	DATE -	REVISED -

**STATE OF ILLINOIS**  
**DEPARTMENT OF TRANSPORTATION**

SCALE:		SHEET 2		OF 2 SHEETS		STA.	TO STA.
		<b>DETAILS</b>					

F.A.P. RTE.	SECTION	COUNTY	TOTAL SHEETS	SHEET NO.
71	(113,112)CJ5	-	8	8
CONTRACT NO. 66L91			ILLINOIS FED. AID PROJECT	