

TREE PRUNING (1 TO 10 INCH DIAMETER)
 STA 19+17.70, 46.8' LT - 6
 STA 18+86.88, 46.2' RT - 6
 STA 20+82.84, 44.9' RT - 5
 STA 21+30.18, 43.3' LT - 4

NOTE: REMOVAL OF EXISTING GUTTER OUTLET IS PAID AS "COMBINATION CURB AND GUTTER REMOVAL"

LEGEND

- HOT-MIX ASPHALT SURFACE REMOVAL, 3" PAVEMENT REMOVAL
- PAVED SHOULDER REMOVAL
- BITUMINOUS SIDEWALK REMOVAL

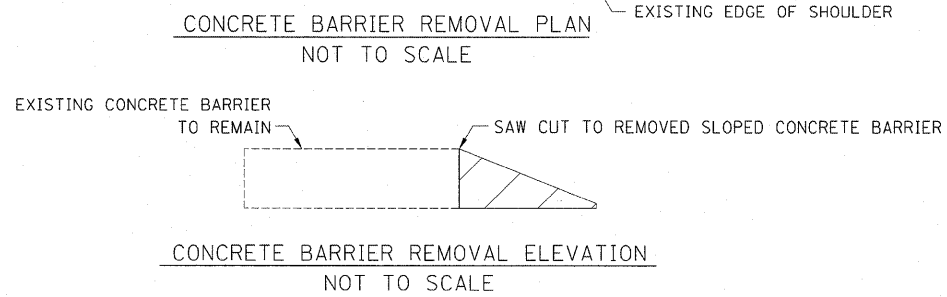
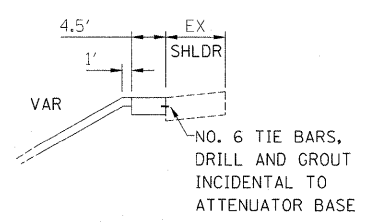
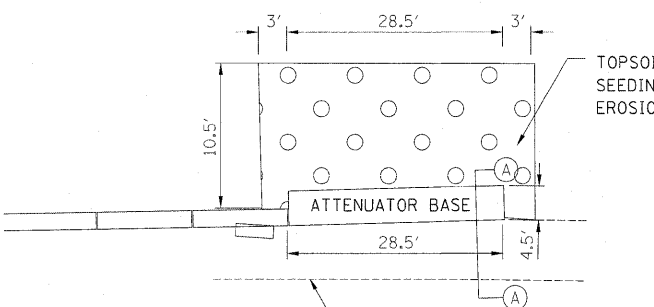
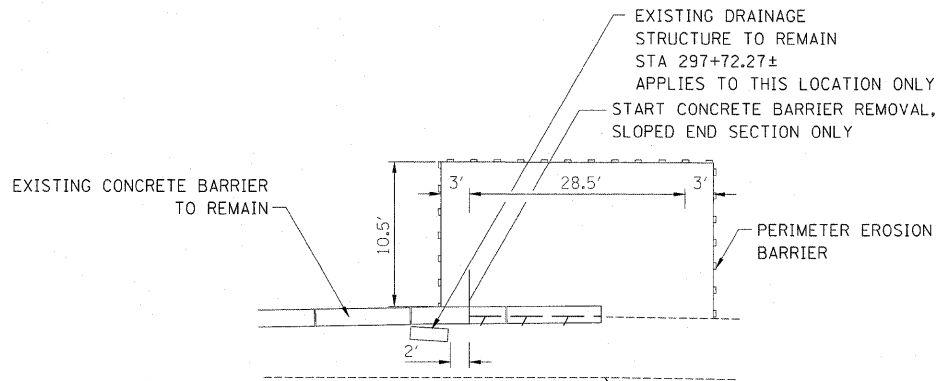

BOWMAN, BARRETT & ASSOCIATES INC.
 CONSULTING ENGINEERS
 Chicago, Illinois
 312.228.0100
 www.bbandainc.com

FILE NAME = 0160C05-shr-rem.dgn	USER NAME = default	DESIGNED -	REVISED - 05/22/2009
		DRAWN - RA	REVISED -
		CHECKED - RS	REVISED -
		DATE - 5/6/2009	REVISED -

**STATE OF ILLINOIS
 DEPARTMENT OF TRANSPORTATION**

REMOVAL PLAN

SCALE: 1" = 50' SHEET NO. 1 OF 1 SHEETS STA. 13+00.00 TO STA. 26+00.00

F.A. RTE. 0353	SECTION 0303.1B-1	COUNTY COOK	TOTAL SHEETS 91	SHEET NO. 11
FED. ROAD DIST. NO. ILLINOIS FED. AID PROJECT			CONTRACT NO. 60C05	

s:\10\03\CAUTION\US30\CA00 Sheets\0160C05-shr-rem.dgn