

F. A. S. R. NO.	SECTION	COUNTY	TOTAL SHEETS	SHEET NO.
2930	09-00117-00-RS	COOK	10	1
STA.		TO STA.		
FED. ROAD DIST. NO. 1		ILLINOIS	FED. AID PROJECT M-9003(219)	

CONTRACT #63159

STATE OF ILLINOIS
DEPARTMENT OF TRANSPORTATION
DIVISION OF HIGHWAYS

**PLANS FOR PROPOSED
FEDERAL AID HIGHWAY**

**FAU 2930 / SCHOOL STREET
138TH STREET (FAU 1597) TO 142ND STREET (FAU 3605)
LOCAL AGENCY PAVEMENT PRESERVATION
STREET RESURFACING
PROJECT: M-9003(219)
SECTION NO.: 09-00117-00-RS
JOB NO.: C-91-276-09
VILLAGE OF RIVERDALE
COOK COUNTY**

INDEX OF SHEETS

- 1 COVER SHEET, INDEX OF SHEETS, LOCATION MAP
- INDEX OF STATE STANDARDS
- 2 SUMMARY OF QUANTITIES & GENERAL NOTES
- 3 TYPICAL CROSS SECTION
- 4 PAVEMENT PLAN
- 5 STRIPING PLAN
- 6-10 DISTRICT 1 STANDARD DETAILS

STATE STANDARDS

- 000001-05 STANDARD STANDARDS, ABBREVIATIONS AND PATTERNS
- 280001-04 TEMPORARY EROSION CONTROL SYSTEMS
- 424001-05 CURB RAMPS FOR SIDEWALK
- 442201-03 CLASS C AND D PATCHES
- 606001-04 CONCRETE CURB AND COMBINATION CONCRETE CURB & GUTTER
- 701301-03 LANE CLOSURE, 2L, 2W, SHORT TIME OPERATIONS
- 701311-03 LANE CLOSURE, 2L, 2W, MOVING OPERATIONS-DAY ONLY
- 701501-05 URBAN LANE CLOSURE, 2L, 2W, UNDIVIDED
- 701801-04 LANE CLOSURE, MULTILANE, 1W OR 2W, CROSSWALK OR SIDEWALK CLOSURE,
- 701901-01 TRAFFIC CONTROL DEVICES
- 780001-02 TYPICAL PAVEMENT MARKINGS

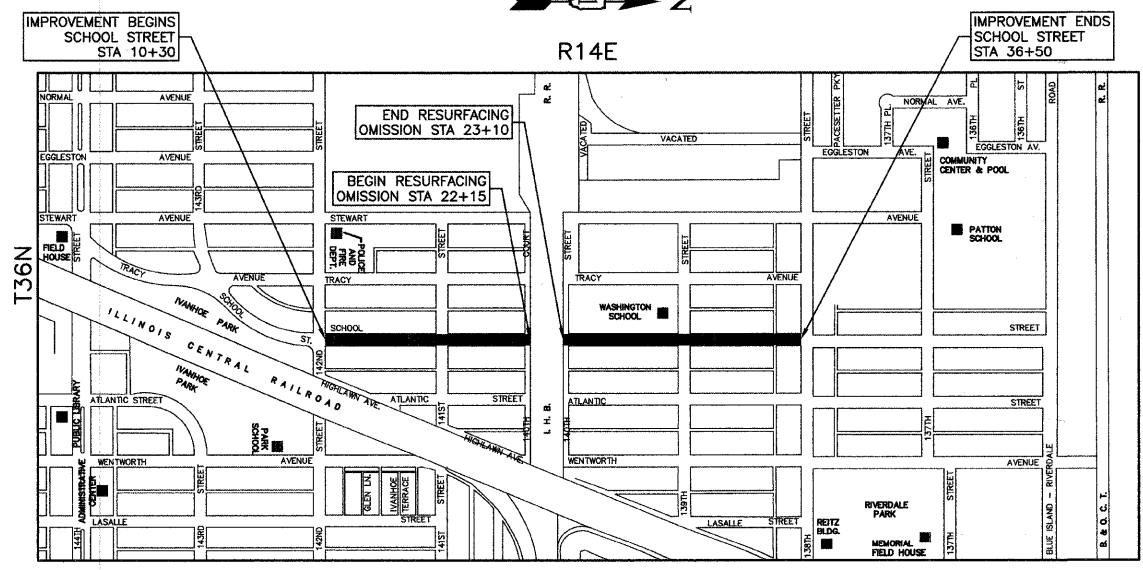
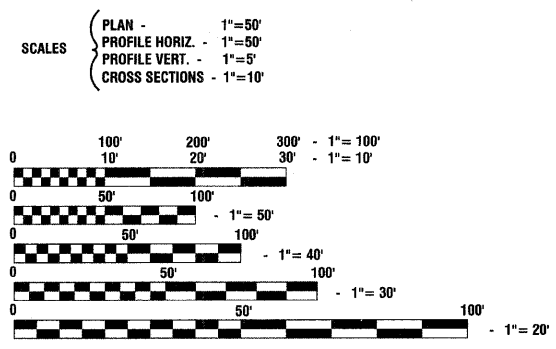
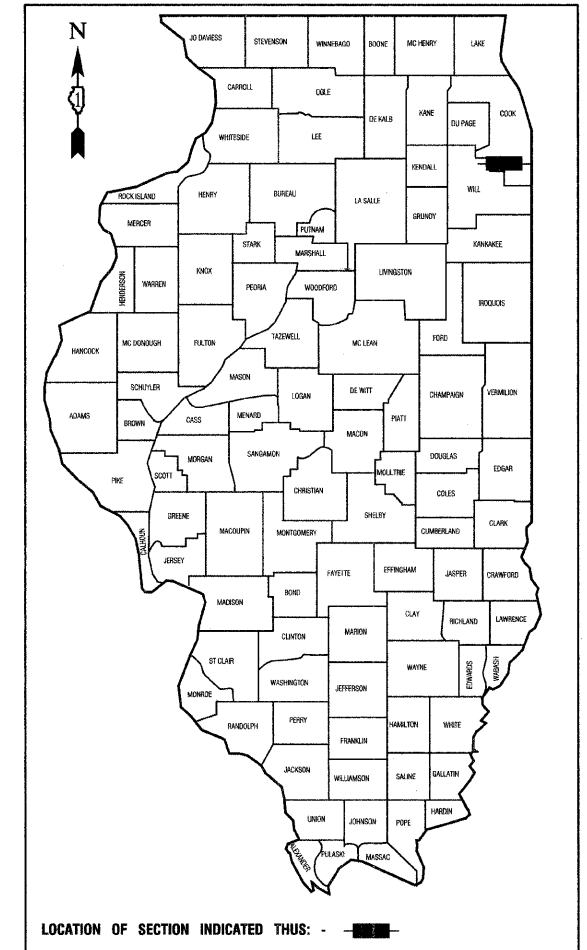

LOCATION MAP

- INDICATES PROPOSED IMPROVEMENT

GROSS LENGTH = 2,620 FEET = 0.496 MILES
NET LENGTH = 2,525 FEET = 0.478 MILES

SCHOOL STREET
ADT=4,800 (2007)
POSTED SPEED LIMIT = 25 MPH
DESIGN SPEED = 25 MPH

STATE OF ILLINOIS DEPARTMENT OF TRANSPORTATION
DIVISION OF HIGHWAYS

Approved: 2-24-2009
Zenobia S. Evans
Mayor, Village of Riverdale

Passed: MARCH 31, 2009
C. Holt CHRISTOPHER HOLT
District 1 Engineer of Local Roads & Streets

Released for Bid Based on Limited Review: MARCH 31, 2009
Diana M. O'Keefe '09
Deputy Director of Highways, Region 1 Engineer

PRINTED BY THE AUTHORITY OF
THE STATE OF ILLINOIS

PREPARED BY OR UNDER THE
DIRECT SUPERVISION OF:
Joseph M. [Signature]
2/23/09

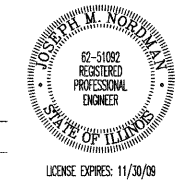

I.D.O.T. FIELD ENGINEER: MELCHOR MANGOBA 847-705-4408
CONSULTANTS: ROBINSON ENGINEERING, LTD. 708-331-6700
CONTACT ENGINEER: JEFF KOZA

J. U. L. I. E.
JOINT UTILITY LOCATION INFORMATION FOR EXCAVATION
1-800-892-0123 or 811

CONTRACT NO. 63159

GENERAL NOTES:

1. BEFORE STARTING ANY EXCAVATION, THE CONTRACTOR SHALL CALL "J.U.L.I.E." AT (800) 892-0123 FOR FIELD LOCATIONS OF BURIED ELECTRIC, TELEPHONE AND GAS UTILITIES. (48 HOUR NOTIFICATION IS REQUIRED).
2. UTILITIES INDICATED ON THE PLANS ARE PROVIDED FOR THE CONTRACTORS USE AND ARE BASED UPON INFORMATION AVAILABLE AT THE TIME OF THE ADVERTISEMENT FOR BIDS. THE OWNER AND ENGINEER DO NOT GUARANTEE THE ACCURACY OF UTILITIES INFORMATION.
3. IT SHALL BE THE CONTRACTOR'S RESPONSIBILITY TO VERIFY ALL DIMENSIONS AND CONDITIONS EXISTING IN THE FIELD PRIOR TO CONSTRUCTION AND ORDERING OF MATERIALS.
4. SCHEDULES INCLUDED IN THE PLANS HAVE BEEN PREPARED FROM FIELD NOTES. EXACT LOCATIONS FOR PATCHING SHALL BE DETERMINED IN THE FIELD BY THE ENGINEER. THE CONTRACTOR SHALL MILL THE EXISTING PAVEMENT PRIOR TO COMMENCING PATCHING OPERATIONS.
5. ANY REFERENCE TO STANDARDS THROUGHOUT THE PLANS OR SPECIAL PROVISIONS SHALL BE INTERPRETED TO BE THE LATEST STANDARDS OF THE ILLINOIS DEPARTMENT OF TRANSPORTATION.
6. THE NOMINAL THICKNESS OF HOT-MIX ASPHALT MIXTURE STATED IN THE SPECIFICATIONS IS THE NOMINAL THICKNESS. DEVIATIONS FROM THE NOMINAL THICKNESS WILL BE PERMITTED WHEN SUCH DEVIATIONS OCCUR DUE TO IRREGULARITIES IN THE EXISTING SURFACE OR BASE ON WHICH THE HOT-MIX ASPHALT SURFACE IS PLACED.
7. ITEMS OF WORK LISTED IN THE SUMMARY OF QUANTITIES WHICH ARE NOT SPECIFICALLY INDICATED IN THE PLANS SHALL BE PERFORMED AT LOCATIONS AS DIRECTED BY THE ENGINEER.
8. THE TOP OF ALL STRUCTURES SHALL BE FLUSH WITH THE ADJACENT SURFACE OR AT THE INDICATED ELEVATIONS SHOWN ON THE PLANS.
9. WHEN, IN THE CONSTRUCTION OPERATION, ANY LOOSE MATERIAL IS DEPOSITED IN THE FLOW LINE OF DITCHES, GUTTERS OR OTHER DRAINAGE STRUCTURES SO THAT THE NATURAL FLOW OF WATER IS OBSTRUCTED, IT SHALL BE REMOVED AT THE CLOSE OF EACH DAY BY THE CONTRACTOR AT HIS EXPENSE. AT THE CONCLUSION OF THE CONSTRUCTION OPERATIONS, ALL DRAINAGE STRUCTURES SHALL BE FREE FROM ALL DIRT AND DEBRIS. THIS WORK SHALL NOT BE PAID FOR SEPARATELY BUT SHALL BE CONSIDERED INCIDENTAL TO THE CONTRACT.
10. THE APPROXIMATE LOCATION OF KNOWN PUBLIC UTILITIES ARE SHOWN ON THE PLANS. HOWEVER, THE DEPARTMENT DOES NOT GUARANTEE ITS ACCURACY. PRIOR TO COMMENCING OPERATIONS ON THE PROJECT WHICH MAY IN ANY WAY CREATE THE POSSIBILITY OF INVOLVEMENT WITH EXISTING UTILITIES, THE CONTRACTOR SHALL CONTACT THE FIRM (OR COMMUNITY) INVOLVED. ADJUSTMENT OF ALL PUBLIC UTILITIES WITHIN THE LIMITS OF THIS IMPROVEMENT WILL BE DONE BY THE RESPECTIVE OWNERS. NO ADDITIONAL COMPENSATION WILL BE ALLOWED DUE TO DELAYS OR INCONVENIENCE CAUSED BY THESE ADJUSTMENTS. IT SHALL BE THE CONTRACTOR'S RESPONSIBILITY TO VERIFY LOCATIONS OF UNDERGROUND INSTALLATION BEFORE STARTING CONSTRUCTION OPERATIONS.
11. COMBINATION CONCRETE CURB AND GUTTER, TYPE M-4.12 SHALL BE INSTALLED WITH A THICKNESS EQUAL TO NINE INCHES (9").
12. THE CONTRACTOR SHALL COORDINATE CONSTRUCTION ACTIVITIES WITH UTILITY COMPANIES.
13. THE CONTRACTOR WILL NOT BE ALLOWED TO SET UP A YARD OR FIELD OFFICE ON VILLAGE PROPERTY WITHOUT WRITTEN PERMISSION FROM THE VILLAGE.
14. BARRICADES: THE CONTRACTOR SHALL PROVIDE AND INSTALL TWO (2) WEIGHTED SAND BAGS ON EACH TYPE I OR TYPE II BARRICADE USED. (ONE (1) WEIGHTED SAND BAG ACROSS EACH BOTTOM RAIL).
15. ALL HMA PAVING SHALL FOLLOW DESIGNATED DRIVING LANES AS SHOWN IN STRIPING DETAILS. NO LONGITUDINAL PAVING JOINT OR SEAMS ARE ALLOWED WITHIN THE DRIVING LANES. ALL LONGITUDINAL PAVING JOINTS OR SEAMS WILL BE BETWEEN THE DRIVING LANES.
16. ALL PAVEMENT, CURB AND SIDEWALK REMOVALS SHALL BE MADE BY MEANS OF STRAIGHT SAW CUT JOINT. THE COST FOR SAW CUTTING SHALL BE INCIDENTAL TO THE CONTRACT.
17. CONTRACTOR SHALL BE RESPONSIBLE AT ALL TIMES FOR TRAFFIC CONTROL AND PROTECTION IN ACCORDANCE WITH THE LATEST IDOT STANDARD SPECIFICATIONS ADOPTED, THE LATEST EDITION OF THE ILLINOIS MANUAL ON UNIFORM TRAFFIC CONTROL DEVICES FOR STREETS AND HIGHWAYS, AND THE STANDARD SPECIFICATIONS FOR TRAFFIC CONTROL ITEMS.
18. THE CONTRACTOR SHALL MAKE EVERY ATTEMPT NOT TO DAMAGE EXISTING TREES.
19. THE CONTRACTOR SHALL MAINTAIN ACCESS TO ALL DRIVEWAYS THROUGHOUT THE RECONSTRUCTION LIMITS AT ALL TIMES. IF DRIVEWAY ACCESS MUST BE RESTRICTED, THE CONTRACTOR SHALL NOTIFY THE RESIDENT IN WRITING 24 HOURS IN ADVANCE.

SUMMARY OF QUANTITIES					PAVEMENT	MARKINGS
S.I.	CODE NO.	PAY ITEM	UNIT	QUAN	CONSTRUCTION TYPE CODE	
					I000	SFTY-1D
	25200650	SODDING, SALT TOLERANT (SPECIAL)	SQ YD	231	231	
	35501308	HOT-MIX ASPHALT BASE COURSE, 6"	SQ YD	70	70	
	40201000	AGGREGATE FOR TEMPORARY ACCESS	TON	7	7	
	40600100	BITUMINOUS MATERIALS (PRIME COAT)	GALLON	899	899	
	40600300	AGGREGATE (PRIME COAT)	TON	9	9	
	40600625	LEVELING BINDER (MACHINE METHOD), N50	TON	377	377	
	40600982	HOT-MIX ASPHALT SURFACE REMOVAL - BUTT JOINT	SQ YD	130	130	
	40603310	HOT-MIX ASPHALT SURFACE COURSE, MIX "C", N50	TON	763	763	
	42400200	PORTLAND CEMENT CONCRETE SIDEWALK, 5"	SQ FT	2015	2015	
	42400800	DETECTABLE WARNINGS	SQ FT	280	280	
	44000158	HOT-MIX ASPHALT SURFACE REMOVAL, 2 1/4"	SQ YD	8988	8988	
	44000200	DRIVEWAY PAVEMENT REMOVAL	SQ YD	70	70	
	44000600	SIDEWALK REMOVAL	SQ FT	2015	2015	
	44001700	COMBINATION CONCRETE CURB AND GUTTER REMOVAL AND REPLACEMENT	FOOT	1022	1022	
	44201741	CLASS D PATCHES, TYPE II, 8 INCH	SQ YD	48	48	
	44201745	CLASS D PATCHES, TYPE III, 8 INCH	SQ YD	60	60	
	44201747	CLASS D PATCHES, TYPE IV, 8 INCH	SQ YD	447	447	
	67100100	MOBILIZATION	L SUM	1	1	
	70102620	TRAFFIC CONTROL AND PROTECTION, STANDARD 701501	L SUM	1	1	
	70102640	TRAFFIC CONTROL AND PROTECTION, STANDARD 701801	L SUM	1	1	
	70300100	SHORT-TERM PAVEMENT MARKING	FOOT	700	700	
	70301000	WORK ZONE PAVEMENT MARKING REMOVAL	SQ FT	233	233	
*	78000100	THERMOPLASTIC PAVEMENT MARKING - LETTERS AND SYMBOLS	SQ FT	80		80
*	78000200	THERMOPLASTIC PAVEMENT MARKING - LINE 4"	FOOT	1451		1451
*	78000400	THERMOPLASTIC PAVEMENT MARKING - LINE 6"	FOOT	598		598
*	78000600	THERMOPLASTIC PAVEMENT MARKING - LINE 12"	FOOT	486		486
*	78000650	THERMOPLASTIC PAVEMENT MARKING - LINE 24"	FOOT	110		110
	Z0017400	DRAINAGE & UTILITY STRUCTURES TO BE ADJUSTED	EACH	23	23	
	Z0017700	DRAINAGE & UTILITY STRUCTURES TO BE RECONSTRUCTED	EACH	1	1	
	Z0048665	RAILROAD PROTECTIVE LIABILITY INSURANCE	L SUM	1	1	

* - INDICATES SPECIALTY ITEMS

LEGEND

- ① EXISTING CURB & GUTTER TO BE REMOVED AT LOCATIONS AS SHOWN ON PLANS OR DIRECTED BY ENGINEER
- ② HOT-MIX ASPHALT SURFACE REMOVAL, 2-1/4"
- ③ EXISTING BITUMINOUS BASE COURSE TO REMAIN, ±6"
- ④ EXISTING P.C. CONCRETE SIDEWALK TO BE REMOVED AT LOCATIONS AS SHOWN ON PLANS OR DIRECTED BY ENGINEER
- ⑤ HOT-MIX ASPHALT SURFACE COURSE, MIX C, N50 1 1/2"
- ⑥ COMBINATION CONCRETE CURB & GUTTER, TYPE M-4.12 AT LOCATIONS AS SHOWN ON PLANS OR DIRECTED BY ENGINEER
- ⑦ LEVELING BINDER (MACHINE METHOD), N50, 3/4"
- ⑧ P.C. CONCRETE SIDEWALK, 5" AT LOCATIONS AS SHOWN ON PLANS OR DIRECTED BY ENGINEER

HOT-MIX ASPHALT MIXTURE REQUIREMENTS

MIXTURE TYPE	AC TYPE	AIR VOIDS
PAVEMENT RESURFACING		
HOT-MIX ASPHALT SURFACE COURSE, MIX C, N50, 1 1/2"	PG 64-22	4% @ 50 Gyr.
LEVELING BINDER (MACHINE METHOD), N50, 3/4"	PG 64-22 *	4% @ 50 Gyr.
DRIVEWAYS		
HOT-MIX ASPHALT SURFACE COURSE, MIX C, N50, 2"	PG 64-22	4% @ 50 Gyr.
HMA BASE COURSE (HMA BINDER IL-19 MM), 6"	PG 64-22 *	4% @ 50 Gyr.
PATCHING		
CLASS D PATCHES, TYPE II, III, IV 8" (HMA BINDER IL-19 MM)	PG 64-22 *	4% @ 70 Gyr.

NOTE:
THE UNIT WEIGHT USED TO CALCULATE ALL HOT-MIX ASPHALT SURFACE MIXTURE QUANTITIES IS 112 LBS/SY/IN.
* WHEN RAP EXCEEDS 20%, THE NEW ASPHALT BINDER IN THE MIX SHALL BE PG 58-22.

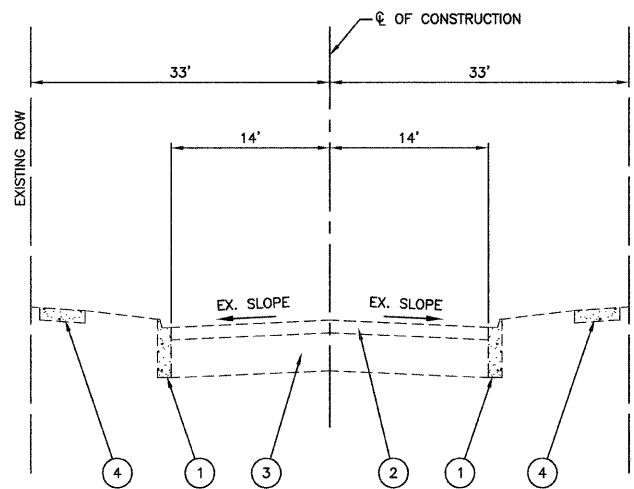

EXISTING TYPICAL CROSS SECTION

142ND STREET TO SOUTH OF BRIDGE OVER IHB RR*
NORTH OF BRIDGE OVER IHB RR TO 139TH STREET

*BRIDGE OVER IHB RR OMITTED FROM RESURFACING
STA 22+15 TO STA 23+10

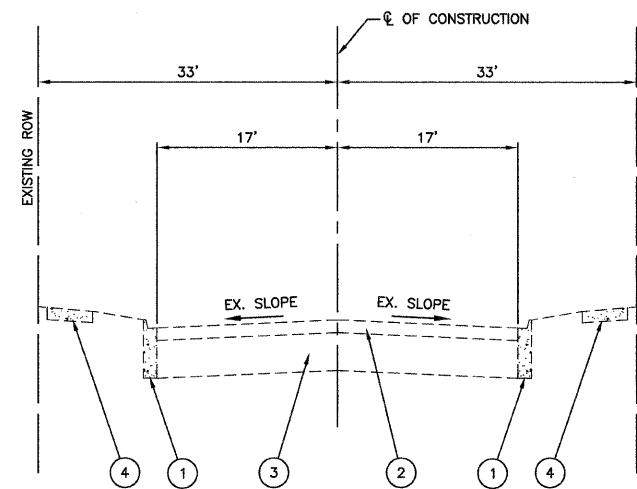

EXISTING TYPICAL CROSS SECTION

139TH STREET TO 138TH STREET

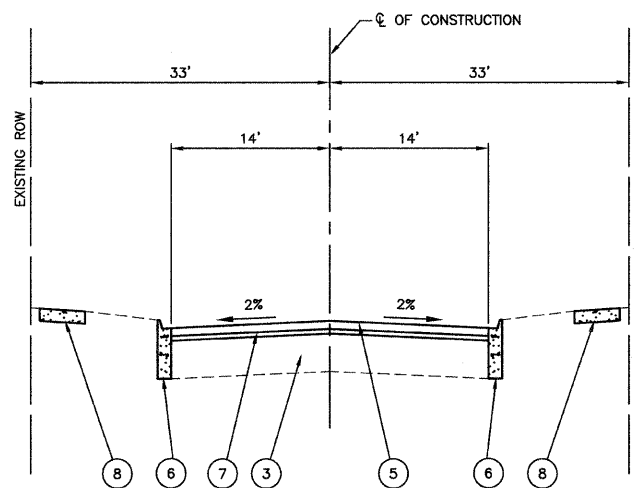

PROPOSED TYPICAL CROSS SECTION

142ND STREET TO SOUTH OF BRIDGE OVER IHB RR*
NORTH OF BRIDGE OVER IHB RR TO 139TH STREET

*BRIDGE OVER IHB RR OMITTED FROM RESURFACING
STA 22+15 TO STA 23+10

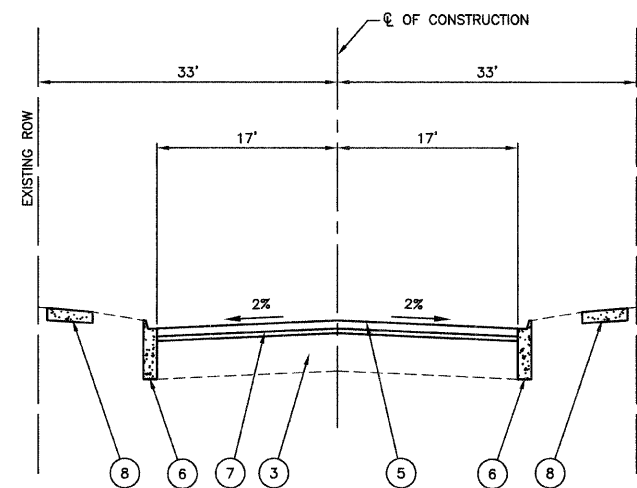

PROPOSED TYPICAL CROSS SECTION

139TH STREET TO 138TH STREET

FILE NAME = 05564-TYPX-01-IDOT P01

USER NAME =	DESIGNED -- JK	REVISED --
	CHECKED -- JMN	REVISED --
PLOT SCALE =	DRAWN -- MJD	REVISED --
PLOT DATE = 02-25-09	CHECKED -- MJD	REVISED --

STATE OF ILLINOIS
DEPARTMENT OF TRANSPORTATION

SCHOOL STREET RESURFACING
142ND STREET TO 138TH STREET
TYPICAL SECTIONS

SCALE: NONE SHEET NO. 3 OF 10 SHEETS STA. TO STA.

F.A.U. RTE.	SECTION	COUNTY	TOTAL SHEETS	SHEET NO.
2930	09-00117-00-RS	COOK	10	3
FED. ROAD DIST. NO. 1		ILLINOIS	FED. AID PROJECT M-9003(219)	
CONTRACT NO. 63159				

142ND STREET

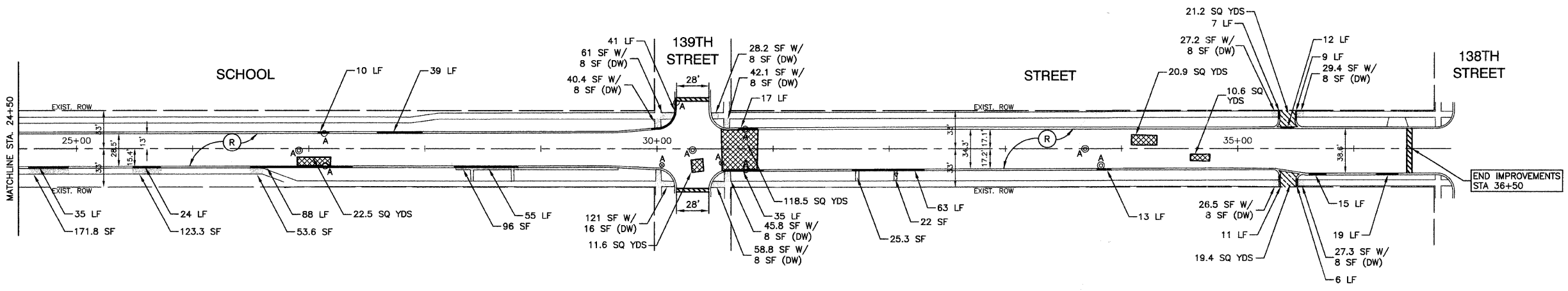
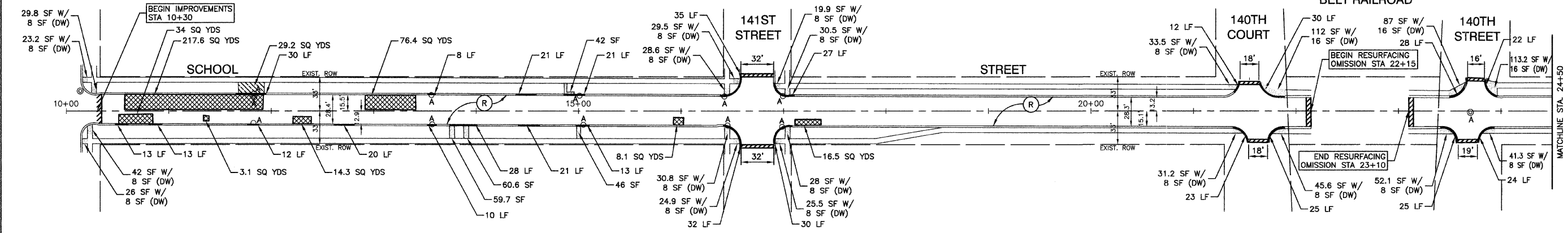

- LEGEND**
- CLASS D PATCH, 8"
 - HOT-MIX ASPHALT DRIVEWAY REMOVAL AND REPLACEMENT
 - HOT-MIX ASPHALT SURFACE REMOVAL - BUTT JOINT
 - CONCRETE SIDEWALK REMOVAL AND REPLACEMENT
 - CONCRETE CURB AND GUTTER REMOVAL AND REPLACEMENT
 - HOT-MIX ASPHALT SURFACE REMOVAL, 2 1/4" LEVELING BINDER (MACHINE METHOD), N50 3/4" HOT-MIX ASPHALT SURFACE COURSE, MIX "C", N50 1 1/2"
 - STRUCTURE TO BE ADJUSTED
 - STRUCTURE TO BE RECONSTRUCTED
 - STRUCTURE TO BE REMOVED AND REPLACED
 - DETECTABLE WARNINGS

FILE NAME = 08594-PLAN-01-IDOT P01	USER NAME =	DESIGNED = JK	REVISED =	<p>STATE OF ILLINOIS DEPARTMENT OF TRANSPORTATION</p>	<p>SCHOOL STREET RESURFACING 142ND STREET TO 138TH STREET PLAN SHEET</p>	F.A.U. RTE. 2930	SECTION 09-00117-00-RS	COUNTY COOK	TOTAL SHEETS 10	SHEET NO. 4	
		CHECKED = JMN	REVISED =		SCALE: 1"=50'	SHEET NO. 4 OF 10 SHEETS	STA. 10+00 TO STA. 36+83.42		CONTRACT NO. 63159		
	PLOT SCALE =	DRAWN = MJD	REVISED =				FED. ROAD DIST. NO. 1		ILLINOIS FED. AID PROJECT M-9003(219)		
	PLOT DATE = 02-25-09	CHECKED = MJD	REVISED =								

142ND STREET

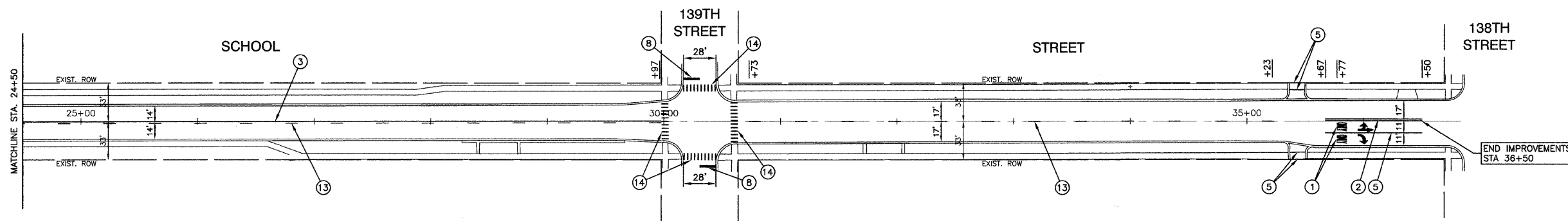
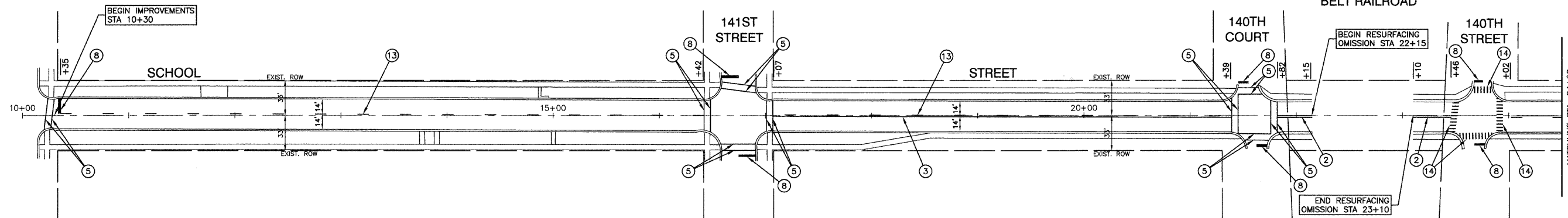

PAVEMENT MARKING LEGEND

- | | |
|--|--|
| ① WHITE LETTERS & SYMBOLS | ⑪ 12" WHITE LINE (45° ANGLE, 20' C/C) |
| ② DOUBLE 4" YELLOW CENTERLINE (11" C/C) | ⑫ 4" WHITE SKIP - DASH LINE (10' LINE - 30' SPACE) |
| ③ 4" YELLOW CENTERLINE | ⑬ 4" YELLOW SKIP - DASH LINE (10' LINE - 30' SPACE) |
| ④ 4" YELLOW MEDIAN OUTLINE | ⑭ 12" WHITE CROSSWALK, 6' LENGTH, 3' C-C |
| ⑤ 4" WHITE EDGE LINE | ⑮ 8" WHITE GORE LINE |
| ⑥ 6" WHITE LANE LINE | ⑯ 4" WHITE PARKING STALL LINE |
| ⑦ 6" WHITE SKIP-DASH LINE (2' LINE - 6' SPACE) | ◀ ONE-WAY AMBER MARKER
40' C/C UNLESS OTHERWISE INDICATED |
| ⑧ 12" YELLOW DIAGONAL LINE (15' C/C) | ◀ ONE-WAY CRYSTAL MARKER
80' C/C UNLESS OTHERWISE INDICATED |
| ⑨ 24" WHITE STOP BAR | ◆ TWO-WAY AMBER MARKER
40' C/C UNLESS OTHERWISE INDICATED |
| ⑩ 6" WHITE CROSSWALK (6' C/C) | ⊠ TRAFFIC SIGN |
| ⑪ 6" WHITE CROSSWALK (10' C/C) | |

NOTE:
ALL LEGEND ITEMS ARE THERMOPLASTIC
PAVEMENT MARKING OF THE WIDTH AND TYPE SPECIFIED

FILE NAME = 06564-PLAN-01-IDDOT P02	USER NAME =	DESIGNED -- JK	REVISED --	STATE OF ILLINOIS DEPARTMENT OF TRANSPORTATION	SCHOOL STREET RESURFACING 142ND STREET TO 138TH STREET STRIPING PLAN	F.A.U. RTE. 2930	SECTION 09-00117-00-RS	COUNTY COOK	TOTAL SHEETS 10	SHEET NO. 5	
	PLOT SCALE =	CHECKED -- JMN	REVISED --			CONTRACT NO. 63159					
	PLOT DATE = 02-25-09	DRAWN -- MJD	REVISED --			SCALE: 1"=50' SHEET NO. 5 OF 10 SHEETS STA. 10+00 TO STA. 36+83.42					
		CHECKED -- MJD	REVISED --			FED. ROAD DIST. NO. 1 ILLINOIS FED. AID PROJECT M-9003(219)					

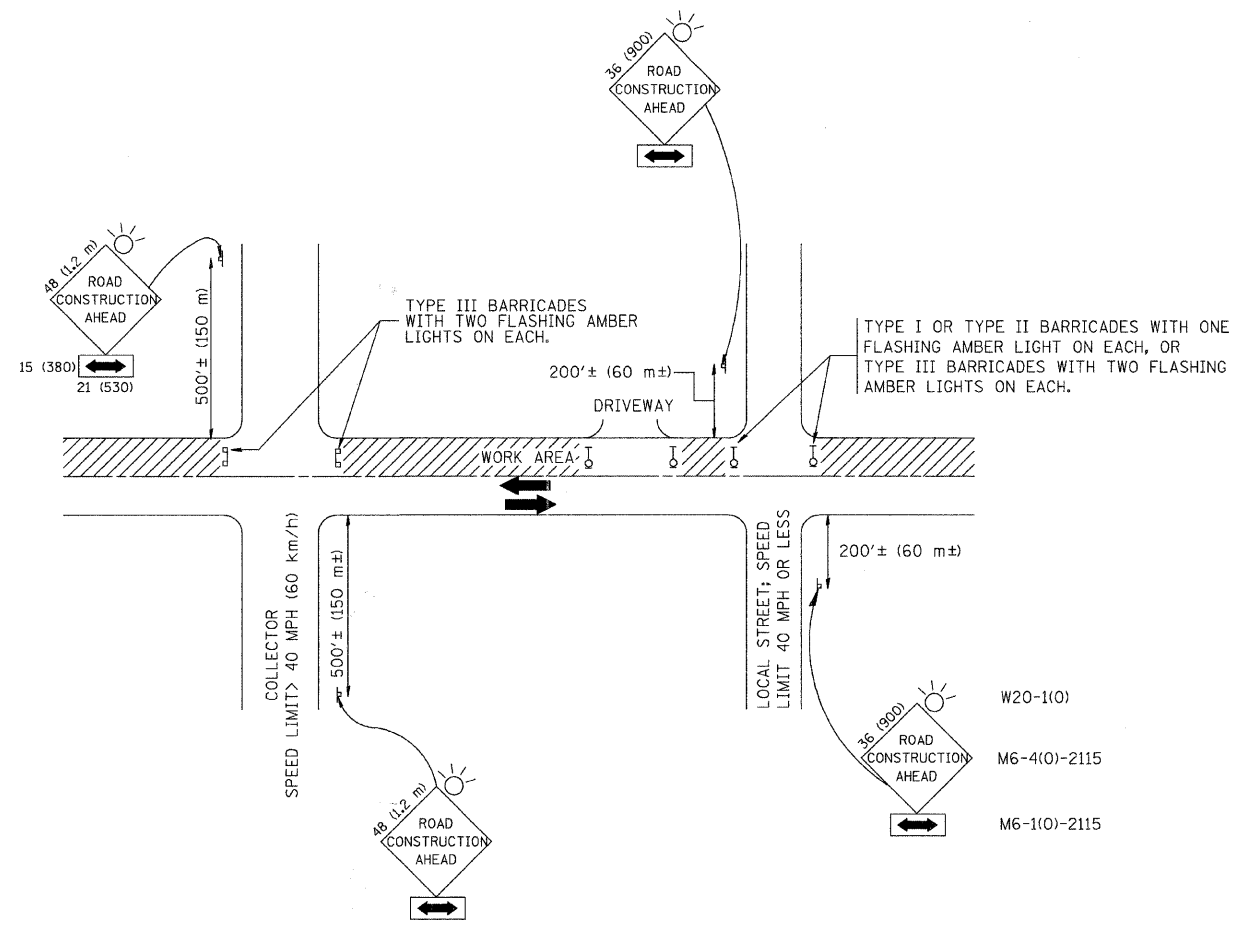

TRAFFIC CONTROL AND PROTECTION FOR SIDE ROADS, INTERSECTIONS, AND DRIVEWAYS

NOTES:

- A. FOR NO LANE RESTRICTION ON THE SIDE ROAD OR DRIVEWAYS
 - 1. SIDE ROAD WITH A SPEED LIMIT OF 40 MPH (60 km/h) OR LESS AS SHOWN ON THE DRAWING AND AS DIRECTED BY THE ENGINEER:
 - a) ONE **ROAD CONSTRUCTION AHEAD** SIGN 36 x 36 (900x900) WITH A FLASHER AND FLAG MOUNTED ON IT APPROXIMATELY 200' (60 m) IN ADVANCE OF THE MAIN ROUTE.
 - b) THE CLOSED PORTION OF THE MAIN ROUTE SHALL BE PROTECTED BY BLOCKING WITH TYPE I, TYPE II OR TYPE III BARRICADES, 1/3 OF THE CROSS SECTION OF THE CLOSED PORTION.
 - 2. SIDE ROAD WITH A SPEED LIMIT GREATER THAN 40 MPH (60 km/h) AS SHOWN ON THE DRAWING AND AS DIRECTED BY THE ENGINEER:
 - a) ONE **ROAD CONSTRUCTION AHEAD** SIGN 48 x 48 (1.2 m x 1.2 m) WITH A FLASHER MOUNTED ON IT APPROXIMATELY 500' (150 m) IN ADVANCE OF THE MAIN ROUTE.
 - b) THE CLOSED PORTION OF THE MAIN ROUTE SHALL BE PROTECTED BY BLOCKING WITH TYPE III BARRICADES, 1/2 OF THE CROSS SECTION OF THE CLOSED PORTION.
 - 3. WHEN THE SIDE ROAD LIES BETWEEN THE BEGINNING OF THE MAINLINE SIGNING AND THE WORK ZONE, A SINGLE HEADED ARROW (M6-1) SHALL BE USED IN LIEU OF THE DOUBLE HEADED ARROW (M6-4).
- B. FOR A LANE CLOSURE ON A SIDE ROAD OR DRIVEWAY:

USE APPLICABLE PORTIONS OF THE TYPICAL APPLICATION OF TRAFFIC CONTROL DEVICES (STD. 701501, STD. 701606 OR THE APPROPRIATE STANDARD). THE SPACING OF SIGNS AND BARRICADES SHALL BE ADJUSTED FOR FIELD CONDITIONS AS DIRECTED BY THE ENGINEER. THE DIRECTIONAL ARROW SHALL BE COVERED OR REMOVED WHEN NO LONGER CONSISTENT WITH THE SIDE ROAD LANE CLOSURE.
- C. ADVANCE WARNING SIGNS ARE TO BE OMITTED ON DRIVEWAY UNLESS OTHERWISE NOTED.
- D. THE TRAFFIC CONTROL AND PROTECTION FOR SIDE ROADS, INTERSECTIONS, AND DRIVEWAYS SHALL BE INCIDENTAL TO THE COST OF SPECIFIED TRAFFIC CONTROL STANDARDS OR ITEMS.

All dimensions are in millimeters (inches) unless otherwise shown.

FILE NAME = 08564-07LS-01 - TC-10	USER NAME = geglianobt	DESIGNED -- LHA	REVISED -- J. OBERLE 10-18-95
		CHECKED --	REVISED -- A. HOUSEH 03-06-96
	PLOT SCALE = 50.000' / IN.	DRAWN --	REVISED -- A. HOUSEH 10-15-96
	PLOT DATE = 1/4/2008	CHECKED -- 06-89	REVISED -- T. RAMMACHER 01-06-00

STATE OF ILLINOIS
DEPARTMENT OF TRANSPORTATION

TRAFFIC CONTROL AND PROTECTION FOR
SIDE ROADS, INTERSECTIONS, AND DRIVEWAYS

SCALE: SHEET NO. 6 OF 10 SHEETS STA. TO STA.

F.A.U. RTE.	SECTION	COUNTY	TOTAL SHEETS	SHEET NO.
2930	09-00117-00-RS	COOK	10	6
TC-10			CONTRACT NO. 63159	
FED. ROAD DIST. NO. 1 ILLINOIS FED. AID PROJECT M-9003(219)				

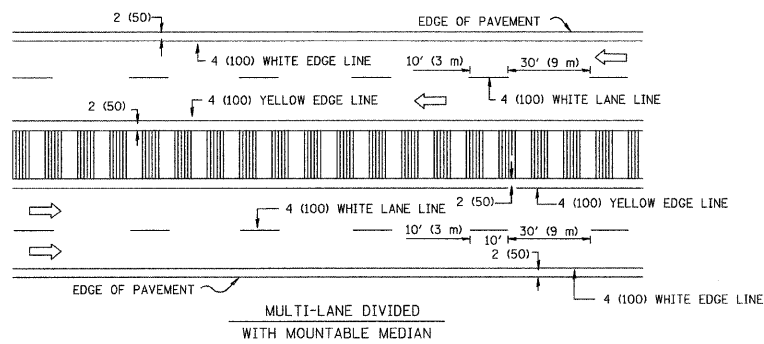
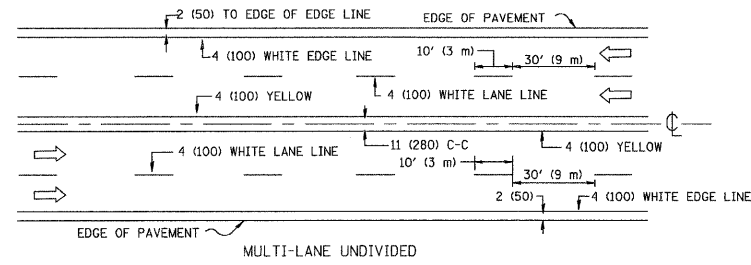
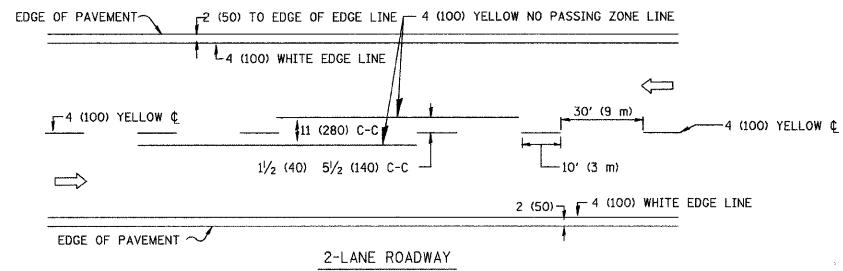

NOTE: MEDIANS WITH BARRIER CURB DO NOT REQUIRE AN EDGE LINE

TYPICAL LANE AND EDGE LINE MARKING

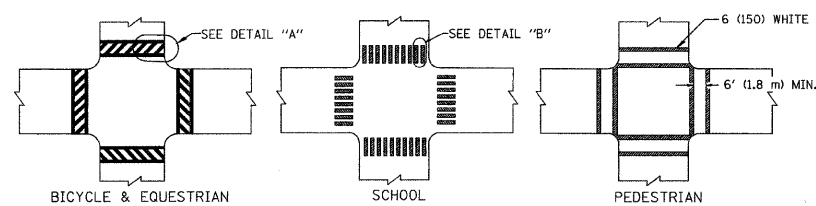

TYPICAL CROSSWALK MARKING

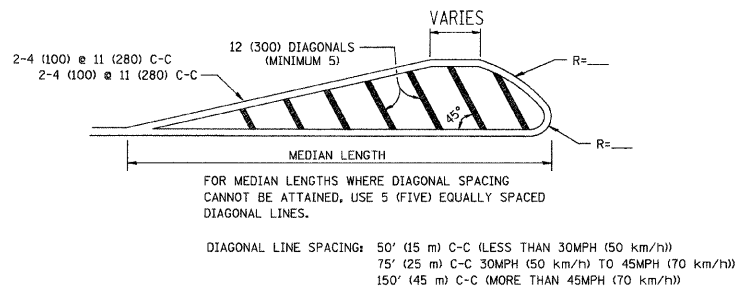
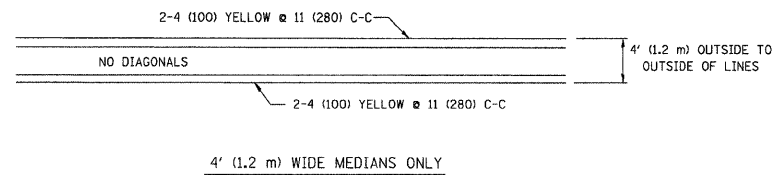

MEDIANS OVER 4' (1.2 m) WIDE

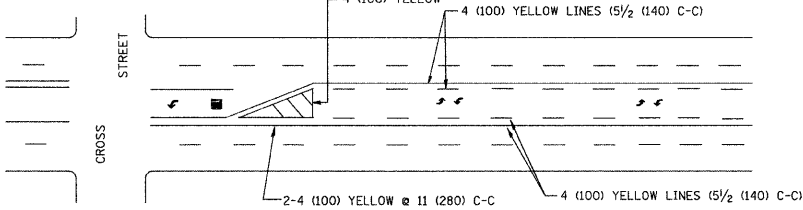

A MINIMUM OF TWO PAIRS OF TURN ARROWS SHALL BE USED, WHITE IN COLOR. ADDITIONAL PAIRS SHALL BE PLACED AT 200' (60 m) TO 300' (90 m) INTERVALS.

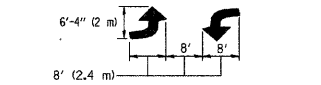

MEDIAN WITH TWO-WAY LEFT TURN LANE

TYPICAL PAINTED MEDIAN MARKING

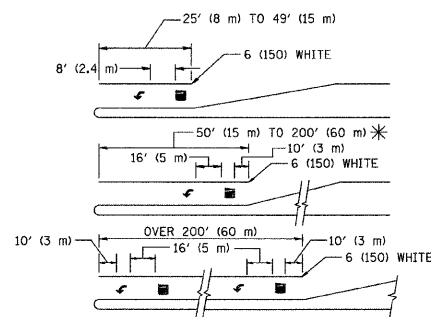

FULL SIZE LETTERS 8' (2.4 m) AND ARROWS SHALL BE USED. AREA = 15.6 SQ. FT. (1.5 m²); ONLY AREA = 20.8 SQ. FT. (1.9 m²)

* TURN LANES IN EXCESS OF 400' (120 m) IN LENGTH MAY HAVE AN ADDITIONAL SET OF ARROW - "ONLY" INSTALLED MIDWAY BETWEEN THE OTHER TWO SETS OF ARROW - "ONLY".

TYPICAL LEFT (OR RIGHT) TURN LANE

TYPICAL TURN LANE MARKING

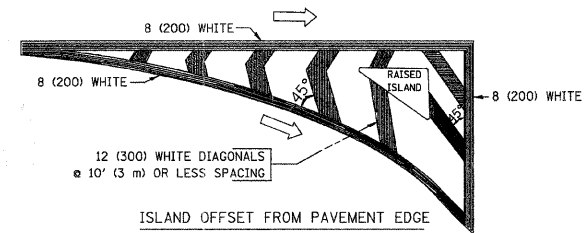

ISLAND OFFSET FROM PAVEMENT EDGE

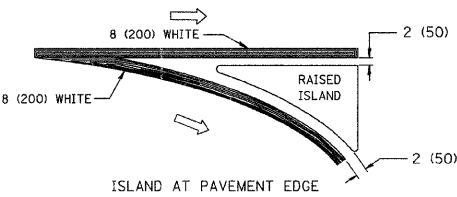

ISLAND AT PAVEMENT EDGE

TYPICAL ISLAND MARKING

TYPE OF MARKING	WIDTH OF LINE	PATTERN	COLOR	SPACING / REMARKS
CENTERLINE ON 2 LANE PAVEMENT	4 (100)	SKIP-DASH	YELLOW	10' (3 m) LINE WITH 30' (9 m) SPACE
CENTERLINE ON MULTI-LANE UNDIVIDED PAVEMENT	2 @ 4 (100)	SOLID	YELLOW	11 (280) C-C
NO PASSING ZONE LINES: FOR ONE DIRECTION FOR BOTH DIRECTIONS	4 (100) 2 @ 4 (100)	SOLID SOLID	YELLOW YELLOW	5/2 (140) C-C FROM SKIP-DASH CENTERLINE 11 (280) C-C OMIT SKIP-DASH CENTERLINE BETWEEN
LANE LINES	4 (100) ON FREEWAYS 5 (125)	SKIP-DASH SKIP-DASH	WHITE WHITE	10' (3 m) LINE WITH 30' (9 m) SPACE
DOTTED LINES (EXTENSIONS OF CENTER, LANE OR TURN LANE MARKINGS)	SAME AS LINE BEING EXTENDED	SKIP-DASH	SAME AS LINE BEING EXTENDED	2' (600) LINE WITH 6' (1.8 m) SPACE
EDGE LINES	4 (100)	SOLID	YELLOW-LEFT WHITE-RIGHT	OUTLINE MOUNTABLE MEDIANS IN YELLOW; EDGE LINES ARE NOT USED NEXT TO BARRIER CURB
TURN LANE MARKINGS	6 (150) LINE; FULL SIZE LETTERS & SYMBOLS (8' (2.4m))	SOLID	WHITE	SEE TYPICAL TURN LANE MARKING DETAIL
TWO WAY LEFT TURN MARKING	2 @ 4 (100) EACH DIRECTION 8' (2.4m) LEFT ARROW	SKIP-DASH AND SOLID IN PAIRS	YELLOW WHITE	10' (3 m) LINE WITH 30' (9 m) SPACE FOR SKIP-DASH; 5/2 (140) C-C BETWEEN SOLID LINE AND SKIP-DASH LINE SEE TYPICAL TWO-WAY LEFT TURN MARKING DETAIL
CROSSWALK LINES (PEDESTRIAN) A. DIAGONALS (BIKE & EQUESTRIAN) B. LONGITUDINAL BARS (SCHOOL)	2 @ 6 (150) 12 (300) @ 45° 12 (300) @ 90°	SOLID SOLID SOLID	WHITE WHITE WHITE	NOT LESS THAN 6' (1.8 m) APART 2' (600) APART SEE TYPICAL CROSSWALK MARKING DETAILS.
STOP LINES	24 (600)	SOLID	WHITE	PLACE 4' (1.2 m) IN ADVANCE OF AND PARALLEL TO CROSSWALK, IF PRESENT. OTHERWISE, PLACE AT DESIRED STOPPING POINT. PARALLEL TO CROSSROAD CENTERLINE, WHERE POSSIBLE.
PAINTED MEDIANS	2 @ 4 (100) WITH 12 (300) DIAGONALS @ 45° NO DIAGONALS USED FOR 4' (1.2 m) WIDE MEDIANS	SOLID	YELLOW: TWO WAY TRAFFIC WHITE: ONE WAY TRAFFIC	11 (280) C-C FOR THE DOUBLE LINE SEE TYPICAL PAINTED MEDIAN MARKING.
GORE MARKING AND CHANNELIZING LINES	8 (200) WITH 12 (300) DIAGONALS @ 45°	SOLID	WHITE	DIAGONALS: 15' (4.5 m) C-C (LESS THAN 30MPH (50 km/h)) 20' (6 m) C-C 30MPH (50 km/h) TO 45MPH (70 km/h) 30' (9 m) C-C (OVER 45MPH (70 km/h))
RAILROAD CROSSING	24 (600) TRANSVERSE LINES; "RR" IS 6' (1.8 m) LETTERS; 15 (400) LINE FOR "X"	SOLID	WHITE	SEE STATE STANDARD 780001 AREA OF: "R"=3.6 SQ. FT. (0.33 m ²) EACH "X"=54.0 SQ. FT. (5.0 m ²)
SHOULDER DIAGONALS	12 (300) @ 45°	SOLID	WHITE - RIGHT YELLOW - LEFT	50' (15 m) C-C (LESS THAN 30MPH (50 km/h)) 75' (25 m) C-C (30 MPH (50 km/h) TO 45MPH (70 km/h)) 150' (45 m) C-C (OVER 45MPH (70 km/h))

FOR FURTHER DETAILS ON PAVEMENT MARKING REFER TO STANDARD SPECIFICATIONS FOR ROAD AND BRIDGE CONSTRUCTION AND STATE STANDARD 780001.

All dimensions are in Inches (millimeters) unless otherwise shown.

FILE NAME = 08594-DT18-02 - TC-13	USER NAME = geglianobt	DESIGNED = EVERS	REVISED = T. RAMMACHER 10-27-94
		CHECKED =	REVISED = A. HOUSEH 10-09-96
	PLOT SCALE = 50,000' / IN.	DRAWN =	REVISED = A. HOUSEH 10-17-96
	PLOT DATE = 1/4/2008	CHECKED = 03-19-90	REVISED = T. RAMMACHER 01-06-00

STATE OF ILLINOIS
DEPARTMENT OF TRANSPORTATION

DISTRICT ONE
TYPICAL PAVEMENT MARKINGS

SCALE: SHEET NO. 7 OF 10 SHEETS STA. TO STA.

F.A.U. RTE. 2930	SECTION 09-00117-00-RS	COUNTY COOK	TOTAL SHEETS 10	SHEET NO. 7
TC-13		CONTRACT NO. 63159		
FED. ROAD DIST. NO. 1 ILLINOIS		FED. AID PROJECT M-9003(219)		

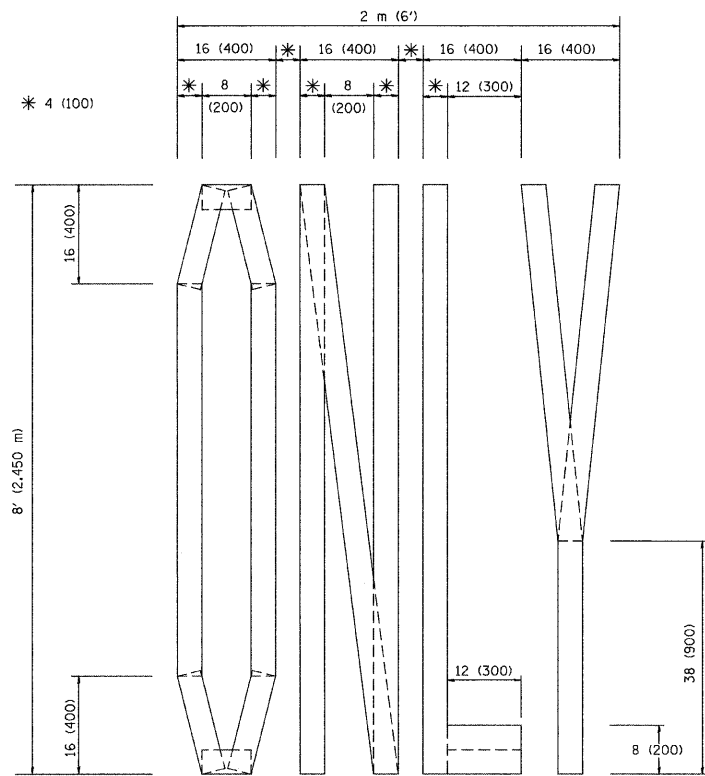

QUANTITY
 4 (100) LINE = 64.1 ft. (19.7 m)
 21.1 sq. ft. (1.97 sq. m)

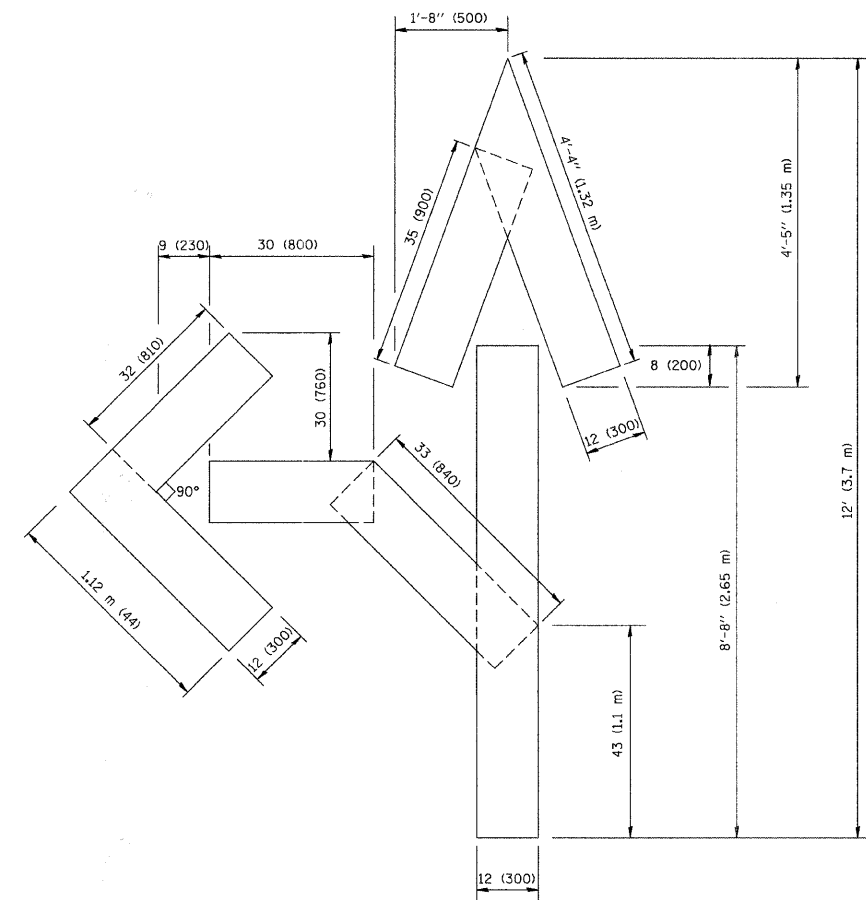

QUANTITY
 4 (100) LINE = 82.5 ft. (25.3 m)
 27.5 sq. ft. (2.53 sq. m)

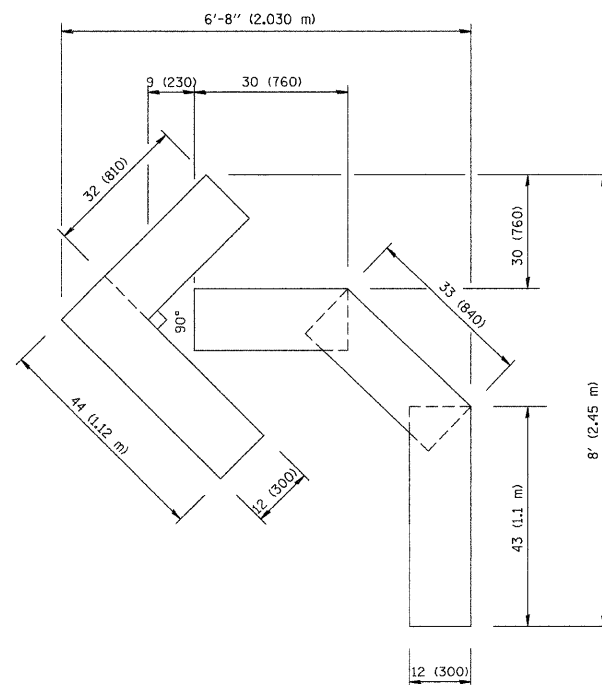

QUANTITY
 4 (100) LINE = 45.5 ft. (13.9 m)
 15.2 sq. ft. (1.39 sq. m)

All dimensions are in inches (millimeters) unless otherwise shown.

FILE NAME = 08564-DTLS-G3 - TC-16	USER NAME = geglianobt	DESIGNED --	REVISED --T. RAMMACHER 06-05-96
		CHECKED --	REVISED --T. RAMMACHER 11-04-97
	PLOT SCALE = 50,0000' / IN.	DRAWN --	REVISED --T. RAMMACHER 03-02-98
	PLOT DATE = 1/4/2008	CHECKED -- 09-18-94	REVISED --E. GOMEZ 08-28-00

STATE OF ILLINOIS
 DEPARTMENT OF TRANSPORTATION

PAVEMENT MARKING LETTERS AND SYMBOLS
 FOR TRAFFIC STAGING

SCALE: SHEET NO. 8 OF 10 SHEETS STA. TO STA.

F.A.U. RTE.	SECTION	COUNTY	TOTAL SHEETS	SHEET NO.
2990	09-00117-00-RS	COOK	10	8
TC-16			CONTRACT NO. 63159	
FED. ROAD DIST. NO. 1 ILLINOIS FED. AID PROJECT M-9003(219)				

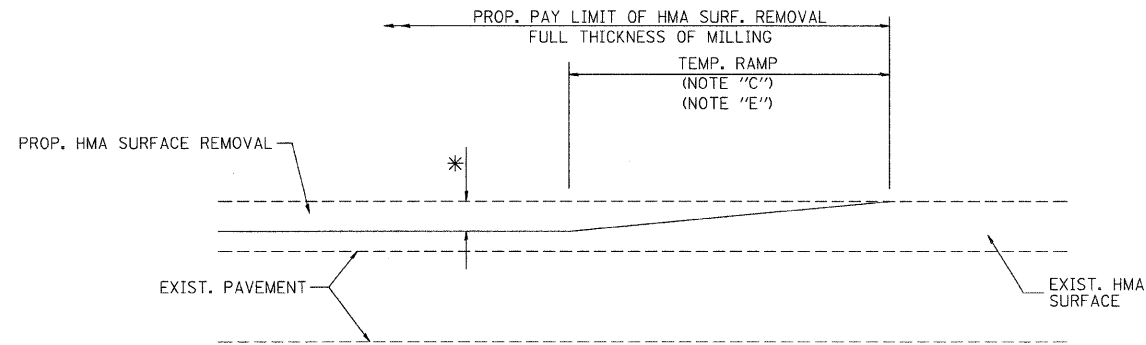

MILLED TEMPORARY RAMP
(FOR BUTT JOINT AND HMA TAPER SEE DETAIL BELOW)

OPTION 1

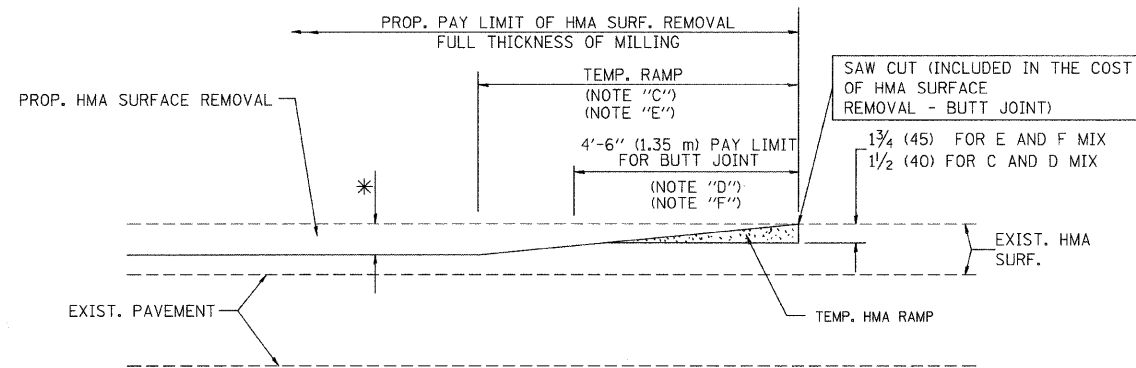

HMA CONSTRUCTED TEMPORARY RAMP
(FOR BUTT JOINT AND HMA TAPER SEE DETAIL BELOW)

OPTION 2

TYPICAL TEMPORARY RAMP

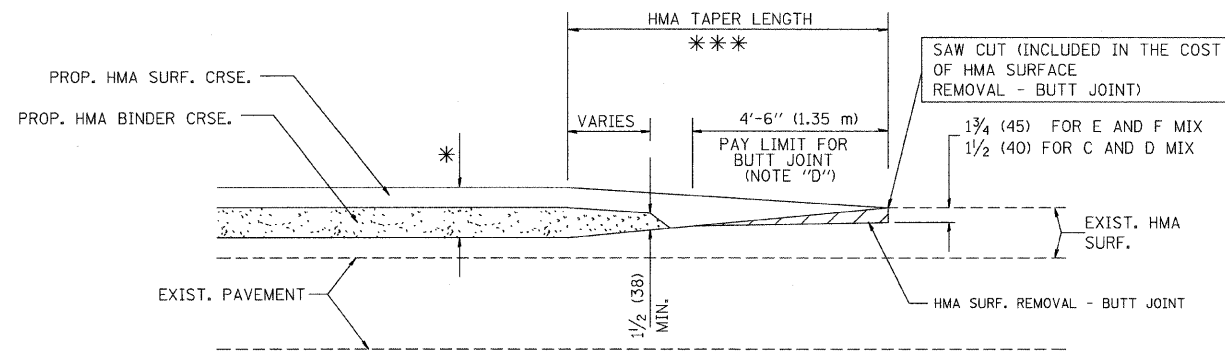

BUTT JOINT AND HMA TAPER
TYPICAL BUTT JOINT AND HMA TAPER
FOR MILLING AND RESURFACING

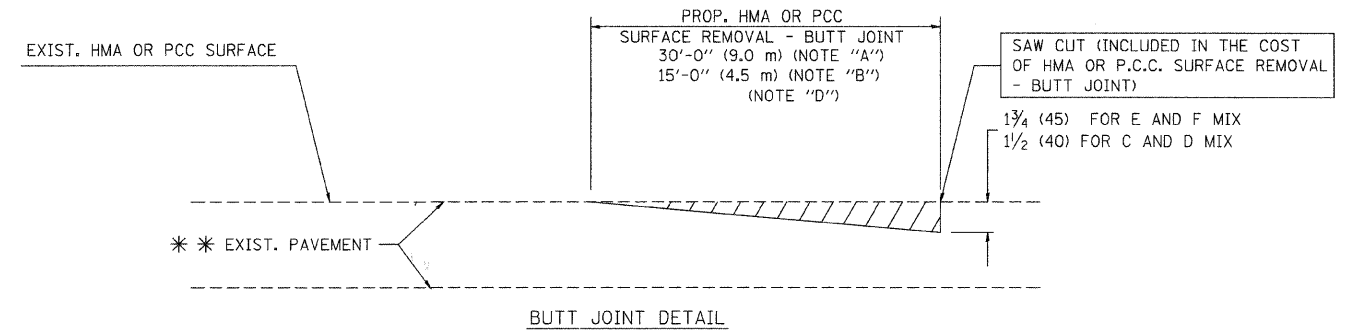

BUTT JOINT DETAIL

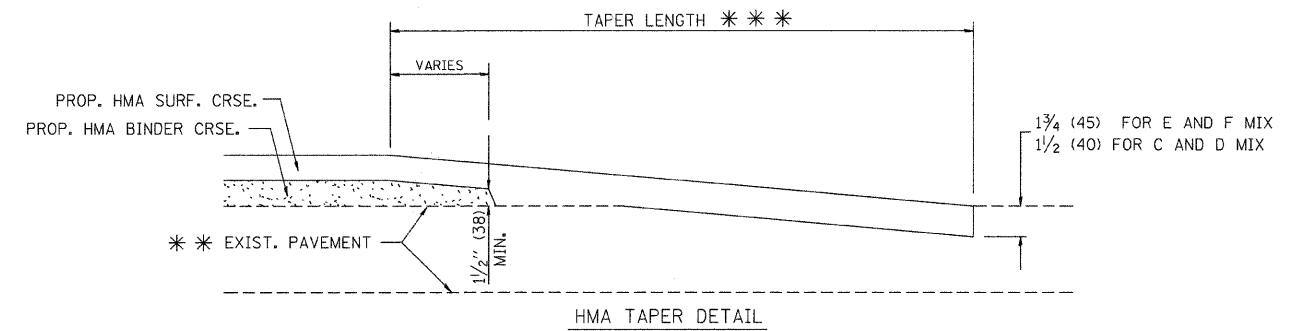

HMA TAPER DETAIL

TYPICAL BUTT JOINT AND HMA TAPER
FOR RESURFACING ONLY

*** PC CONCRETE, HMA OR HMA RESURFACED PAVEMENT.

NOTES

- A: MAINLINE ROADWAYS AND MAJOR SIDE ROADS.
 - B: MINOR SIDE ROADS.
 - C: THE TEMP. RAMP SHALL BE CONSTRUCTED IMMEDIATELY UPON REMOVAL OF THE EXISTING HMA SURFACE.
 - D: THE BUTT JOINT SHALL BE CONSTRUCTED IMMEDIATELY PRIOR TO PLACING THE PROPOSED HMA COURSES.
 - E: TAPER THE TEMP. RAMP AT A RATE OF 3'-0" (900 mm) PER 1 INCH (25 mm) OF MILLING THICKNESS.
 - F: INSTALLATION AND REMOVAL OF THE 4'-6" (1.35 m) TEMP. RAMP IS INCLUDED IN COST OF HMA SURFACE REMOVAL - BUTT JOINT
 - G: SEE ARTICLE 406.08 AND 406.14 OF THE STANDARD SPECIFICATIONS FOR "HMA AND/OR PCC SURFACE REMOVAL, BUTT JOINT".
- * SEE TYPICAL SECTIONS FOR MILLING THICKNESS.
- *** 20'-0" (6.1 m) PER 1 (25) RESURFACING (NOTE "A")
10'-0" (3.0 m) PER 1 (25) RESURFACING (NOTE "B")

BASIS OF PAYMENT:

THE BUTT JOINT WILL BE PAID FOR AT THE CONTRACT UNIT PRICE PER SQUARE YARD (SQUARE METER) FOR "HOT-MIX ASPHALT SURFACE REMOVAL - BUTT JOINT" OR FOR "PORTLAND CEMENT CONCRETE SURFACE REMOVAL - BUTT JOINT".

ALL DIMENSIONS ARE IN INCHES (MILLIMETERS) UNLESS OTHERWISE SHOWN.

FILE NAME = 08564-DTLS-05 - BD-32	USER NAME = geglennob	DESIGNED -- M. DE YONG	REVISED -- R. SHAH 10-25-94
		CHECKED --	REVISED -- A. ABBAS 03-21-97
PLOT SCALE = 50.0000' / IN.	DRAWN --	REVISED -- M. GOMEZ 04-06-01	
PLOT DATE = 1/4/2008	CHECKED -- 06-13-90	REVISED -- R. BORO 01-01-07	

STATE OF ILLINOIS
DEPARTMENT OF TRANSPORTATION

BUTT JOINT AND
HMA TAPER DETAILS

SCALE: SHEET NO. 10 OF 10 SHEETS STA. TO STA.

F.A.U. RTE.	SECTION	COUNTY	TOTAL SHEETS	SHEET NO.
2930	09-00117-00-RS	COOK	10	10
BD400-05 BD32			CONTRACT NO. 63159	
FED. ROAD DIST. NO. 1 ILLINOIS FED. AID PROJECT M-9003(219)				