

# STATE OF ILLINOIS DEPARTMENT OF TRANSPORTATION DIVISION OF HIGHWAYS PLANS FOR PROPOSED FEDERAL AID PROJECT LOCAL AGENCY PAVEMENT PRESERVATION (LAPP) THATCHER AVENUE (FAU 2753) CENTRAL AVENUE TO CHICAGO AVENUE SECTION NO. 09-00089-00-RS PROJECT NO. ARA-9003(349) VILLAGE OF RIVER FOREST COOK COUNTY JOB NO. C-91-663-09

ROUTE NO.	SECTION	COUNTY	TOTAL SHEETS	SHEET NO.
2753	09-00089-00-RS	COOK	15	1
ILLINOIS PROJECT ARA-9003(349)				
VILLAGE SECTION 09-00089-00-RS				
CONTRACT NO. 63215				

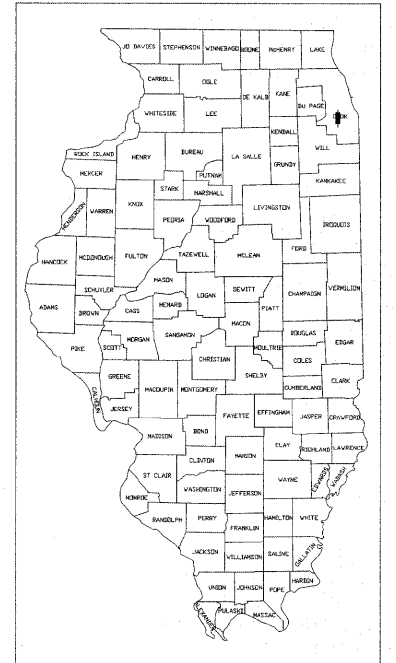

LOCATION OF SECTION INDICATED THUS:

**TRAFFIC DATA**

2030 ADT = 6,800  
POSTED SPEED LIMIT = 30 M.P.H.  
DESIGN SPEED = 30 M.P.H.

**DESIGN DESIGNATION**

COLLECTOR

PROJECT LOCATED IN THE VILLAGE OF RIVER FOREST

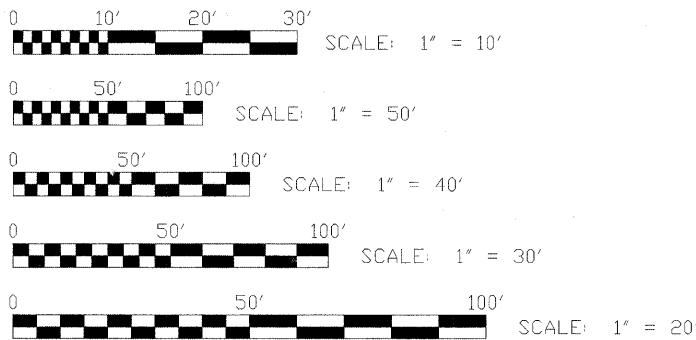

FULL SIZE PLANS HAVE BEEN PREPARED USING STANDARD ENGINEERING SCALES. REDUCED SIZED PLANS WILL NOT CONFORM TO STANDARD SCALES. IN MAKING MEASUREMENTS ON REDUCED PLANS, THE ABOVE SCALES MAY BE USED.

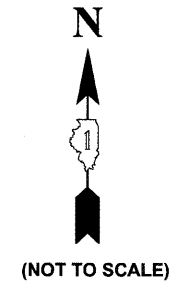
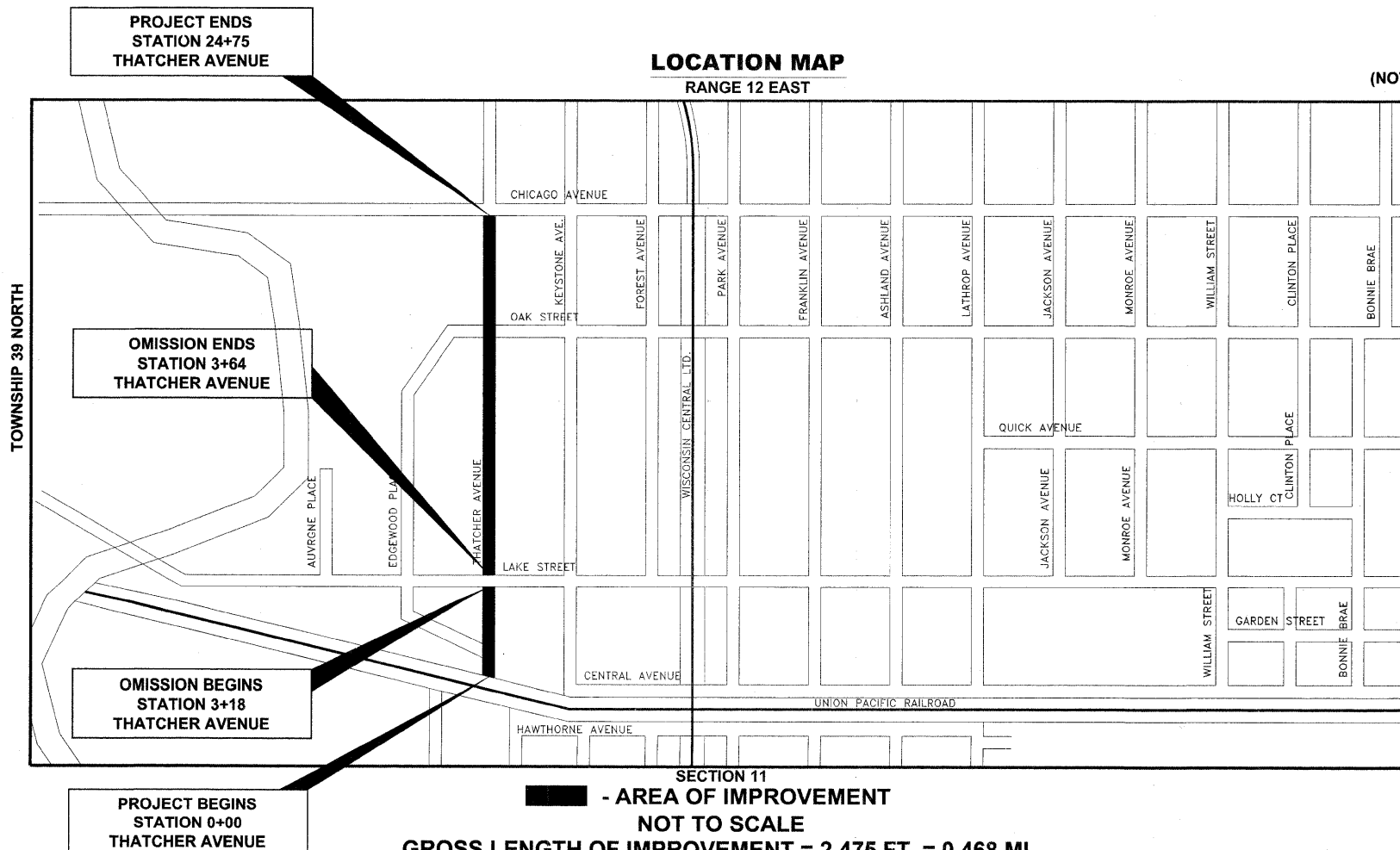

**STATE OF ILLINOIS  
ILLINOIS DEPARTMENT OF TRANSPORTATION  
DIVISION OF HIGHWAYS**

APPROVED 06-02-2009 20  
*Gregory W. Kraus*  
DIRECTOR OF PUBLIC WORKS, VILLAGE OF RIVER FOREST

PASSED JUNE 5 2009  
*John J. Henschel*  
DISTRICT 11 ENGINEER OF LOCAL ROADS & STREETS

RELEASED FOR BID  
BASED ON LIMITED  
REVIEW JUNE 5, 2009  
*Diane M. O'Keefe*  
DEPUTY DIRECTOR OF HIGHWAYS, 9th  
REGION 1 ENGINEER

(PRINTED BY AUTHORITY OF THE STATE OF ILLINOIS)



DATE SIGNED: 6/22/09  
LICENSE EXPIRES: 11-30-09

EDWIN HANCOCK ENGINEERING COMPANY  
9933 ROOSEVELT ROAD PHONE : (708) 865-0300  
WESTCHESTER, ILLINOIS 60154



**Know what's below.  
Call before you dig.**

CONTRACT NO. 63215

FIELD ENGINEER: MARILYN SOLOMON, (847)705-4407  
Drawing file: W:\Projects\74009075 - Thatcher Ave COVER.dwg Jun 02, 2009 - 10:31am

## INDEX OF SHEETS

SHEET NO.	DESCRIPTION
1	COVER SHEET, LOCATION MAP
2	INDEX OF SHEETS AND I.D.O.T. STANDARD DRAWINGS
3	GENERAL NOTES
4	SUMMARY OF QUANTITIES
5-6	EXISTING TYPICAL CROSS SECTIONS AND PROPOSED TYPICAL CROSS SECTIONS
7	DETAILS & NOTES
8	TRAFFIC SIGNAL DETECTOR LOOP REPLACEMENT PLAN
9	DETAILS FOR FRAMES AND LIDS ADJUSTMENT WITH MILLING (BD 08)
10	CURB AND GUTTER REMOVAL AND REPLACEMENT (BD 24)
11	BUTT JOINT AND HMA TAPER DETAILS (BD 32)
12	TRAFFIC CONTROL AND PROTECTION FOR SIDE ROADS, INTERSECTIONS, AND DRIVEWAYS (TC 10)
13	DISTRICT ONE TYPICAL PAVEMENT MARKINGS (TC 13)
14	TRAFFIC CONTROL AND PROTECTIONS AT TURN BAYS (TO REMAIN OPEN TO TRAFFIC) (TC 14)
15	DISTRICT ONE - DETECTOR LOOP INSTALLATION DETAILS FOR ROADWAY RESURFACING (TS 07)

## I.D.O.T. STANDARD DRAWINGS

STANDARD NO.	TITLE OR DESCRIPTION
000001-05	STANDARD SYMBOLS, ABBREVIATIONS AND PATTERNS
424001-05	CURB RAMPS FOR SIDEWALKS
442101-07	CLASS B PATCHES
604001-03	FRAMES AND LIDS, TYPE 1
701501-05	URBAN LANE CLOSURE, 2-LANE, 2-WAY, UNDIVIDED
701606-06	URBAN LANE CLOSURE, MULTILANE, 2-WAY, WITH MOUNTABLE MEDIAN
701701-06	URBAN LANE CLOSURE, MULTILANE INTERSECTION
701801-04	LANE CLOSURE, MULTILANE, 1W OR 2W CROSSWALK OR SIDEWALK CLOSURE
701901-01	TRAFFIC CONTROL DEVICES
780001-02	TYPICAL PAVEMENT MARKINGS

### DISTRICT ONE DETAILS

BD 08	DETAILS FOR FRAMES AND LIDS ADJUSTMENT WITH MILLING
BD 24	CURB AND GUTTER REMOVAL AND REPLACEMENT
BD 32	BUTT JOINT AND HMA TAPER DETAILS
TC 10	TRAFFIC CONTROL AND PROTECTION FOR SIDE ROADS, INTERSECTIONS, AND DRIVEWAYS
TC 13	DISTRICT ONE TYPICAL PAVEMENT MARKINGS
TC 14	TRAFFIC CONTROL AND PROTECTIONS AT TURN BAYS (TO REMAIN OPEN TO TRAFFIC)
TS 07	DISTRICT ONE - DETECTOR LOOP INSTALLATION DETAILS FOR ROADWAY RESURFACING

Drawing file: W:\Projects\74009075 - Thatcher Ave\INDEX.dwg Jun 02, 2009 - 11:14am



933 Roosevelt Road  
 Westchester, Illinois 60154-1700  
 Phone: 708.965-4100  
 Fax: 708.965-1212

USER NAME	DESIGNED	CH	REVISED
	DRAWN	MK	REVISED
PLOT SCALE	CHECKED	CH	REVISED
	DATE	4-21-09	REVISED
PLOT DATE			

**STATE OF ILLINOIS  
 DEPARTMENT OF TRANSPORTATION**

**INDEX OF SHEETS AND I.D.O.T.  
 STANDARD DRAWINGS**

SCALE: NONE SHEET NO. OF SHEETS STA. TO STA.

F.A.U. RTE.	SECTION	COUNTY	TOTAL SHEETS	SHEET NO.
2753	09-00089-00-RS	COOK	15	2
FED. ROAD DIST. NO. 1 ILLINOIS FED. AID PROJECT			CONTRACT NO. 63215	
			ARA-9003(349)	

E.H.E. PROJECT NO. 740-09-07501

# GENERAL NOTES

## STANDARDS

ANY REFERENCE TO STANDARDS THROUGHOUT THE PLANS OR SPECIAL PROVISIONS SHALL BE INTERPRETED TO BE THE LATEST STANDARD OF THE ILLINOIS DEPARTMENT OF TRANSPORTATION AS SHOWN ON THE INDEX OF SHEETS IN THE PLANS. ALL CONSTRUCTION SHALL BE DONE IN ACCORDANCE WITH THE STANDARD SPECIFICATIONS FOR ROAD AND BRIDGE CONSTRUCTION ADOPTED JANUARY 1, 2007, THE "SUPPLEMENTAL SPECIFICATIONS AND RECURRING SPECIAL PROVISIONS" ADOPTED JANUARY 1, 2009, THE LATEST EDITION OF THE "ILLINOIS MANUAL ON UNIFORM TRAFFIC CONTROL DEVICES FOR STREETS AND HIGHWAYS," "THE STANDARD SPECIFICATIONS FOR WATER AND SEWER MAIN CONSTRUCTION IN ILLINOIS" MAY 1996 FIFTH EDITION, AND THE "DETAILS" IN THE PLANS AND THE "SPECIAL PROVISIONS" INCLUDED IN THE CONTRACT DOCUMENTS.

## UNDERGROUND UTILITIES

BEFORE STARTING ANY EXCAVATION, THE CONTRACTOR SHALL CALL "JULIE" AT 811 FOR FIELD LOCATIONS OF BURIED ELECTRICAL, TELEPHONE AND GAS FACILITIES. (48 HOURS NOTIFICATION IS REQUIRED).

THE LOCATIONS OF THE UNDERGROUND UTILITIES IF SHOWN ON THE PLANS HAVE BEEN OBTAINED BY FIELD SURVEYS AND SEARCHES OF AVAILABLE RECORDS. IT IS BELIEVED THAT DATA IS ESSENTIALLY CORRECT, BUT THE VILLAGE OF RIVER FOREST, THE ILLINOIS DEPARTMENT OF TRANSPORTATION AND/OR OTHER OFFICES AND AGENCIES ASSOCIATED WITH THE DEVELOPMENT OF THESE PLANS DO NOT GUARANTEE THEIR ACCURACY OR COMPLETENESS. THE CONTRACTOR WILL BE REQUIRED TO VERIFY THE EXACT LOCATION OF EACH FACILITY WITH THE UTILITY COMPANY, AND SHALL TAKE DUE CARE IN ALL PHASES OF THE CONSTRUCTION TO PROTECT ANY SUCH FACILITIES WHICH MAY BE AFFECTED BY THE WORK. ANY DAMAGE TO EXISTING UTILITIES SHALL BE REPAIRED AT THE CONTRACTOR'S EXPENSE.

THE CONTRACTOR SHALL COORDINATE CONSTRUCTION ACTIVITIES WITH UTILITY COMPANIES AND THE VILLAGE OF RIVER FOREST.

## FRAMES AND LIDS

THE TYPE OF FRAMES AND LIDS REQUIRED FOR ALL MANHOLES AND VALVE VAULTS LISTED IN THE SUMMARY OF QUANTITIES MAY BE FOUND ON THE PLANS AT THEIR RESPECTIVE LOCATIONS. WHERE LIDS ARE CALLED FOR ON THE PLANS, THEY SHALL BE IN ACCORDANCE WITH ARTICLE 604.04 OF THE STANDARD SPECIFICATIONS AND THE TERM LID IS USED IN LIEU OF GRATE. ALL LIDS ON SANITARY MANHOLES, COMBINED SEWER MANHOLES, AND VALVE VAULTS SHALL BE OF THE SELF SEALING TYPE.

ON ALL IMPROVEMENTS, THE FRAMES AND LIDS OF EXISTING CATCH BASINS, INLETS, MANHOLES, AND VALVE VAULTS WHICH ARE TO BE ABANDONED DUE TO CONSTRUCTION OF THIS IMPROVEMENT ARE TO REMAIN THE PROPERTY OF THE VILLAGE OF FOREST PARK AND BE SALVAGED. THESE ITEMS SHALL BE DELIVERED TO THE VILLAGE OF RIVER FOREST PUBLIC WORKS DEPARTMENT LOCATED AT 400 PARK AVENUE.

## MANHOLE OR VALVE COVERS

THE WORD "WATER", "SANITARY", OR "STORM" SHALL BE CAST INTO THE LID OF EACH RESPECTIVE MANHOLE OR VALVE VAULT.

## MAINTENANCE OF SEWER FLOWS

THE CONTRACTOR SHALL CONDUCT HIS OPERATIONS AS TO MAINTAIN AT ALL TIMES FLOW THROUGH EXISTING STORM AND SANITARY SEWER SYSTEMS. HE SHALL ALSO PROVIDE AND MAINTAIN AN EFFICIENT PUMPING PLANT IF NECESSARY AND A TEMPORARY OUTLET AND BE PREPARED AT ALL TIMES TO DISPOSE OF THE WATER COLLECTED IN A SAFE MANNER WITHOUT DAMAGE OF ANY KIND TO ADJACENT PROPERTIES. THE ENDS OF EXISTING DRAINAGE LINES WHICH ARE NOT TO BE INCORPORATED INTO THE PROJECT ARE TO BE SEALED AS SPECIFIED IN THE SPECIAL PROVISIONS. EXISTING STRUCTURES ARE TO BE INSPECTED BEFORE CONSTRUCTION STARTS - ANY ACCUMULATION OF MATERIAL IN THE STRUCTURE DUE TO CONSTRUCTION OPERATIONS SHALL BE REMOVED BY THE CONTRACTOR AT HIS EXPENSE.

## MAINTENANCE OF EXISTING DRAINAGE STRUCTURES

WHEN DURING THE CONSTRUCTION OPERATIONS, ANY LOOSE MATERIAL IS DEPOSITED IN THE FLOW LINE OF ANY GUTTERS AND DRAINAGE STRUCTURE SO THAT THE NATURAL FLOW OF WATER IS OBSTRUCTED, IT SHALL BE REMOVED AT THE CLOSE OF EACH WORKING DAY. AT THE CONCLUSION OF THE CONSTRUCTION OPERATIONS, ALL DRAINAGE FACILITIES SHALL BE CLEAN AND FREE OF ALL OBSTRUCTIONS DUE TO CONSTRUCTION OPERATIONS. THE COST OF THIS WORK SHALL BE INCIDENTAL TO THE CONTRACT.

## SAW CUTTING

THE CONTRACTOR SHALL SAW CUT ASPHALT PAVEMENT AS INDICATED ON THE PLANS TO SEPARATE THE EXISTING PAVEMENT TO BE REMOVED BY APPROVED MEANS OR AN APPROVED CONCRETE SAW TO A DEPTH AS DIRECTED BY THE ENGINEER. SUITABLE GUIDELINES OR DEVICES SHALL BE USED TO ASSURE CUTTING A NEAT, STRAIGHT LINE AS SHOWN ON THE PLANS. CARE SHALL BE TAKEN BY THE CONTRACTOR AS NOT TO DAMAGE THE REMAINING PAVEMENT DIRECTLY ADJACENT TO THE PAVEMENT TO BE REMOVED. ANY DAMAGE TO THE EXISTING PAVEMENT RESULTING FROM PAVEMENT REMOVAL OPERATIONS SHALL BE REPAIRED AT THE CONTRACTOR'S EXPENSE. THE COST OF SAW CUTTING DESCRIBED ABOVE SHALL BE INCLUDED IN THE ITEM BEING REMOVED. SAW CUTS FOR PAVEMENT PATCHING WILL BE PAID FOR IN THE CONTRACT.

## FRAMES AND LIDS TO BE ADJUSTED (SPECIAL)

THIS ITEM ONLY PERTAINS TO STRUCTURES LOCATED IN THE CONCRETE OR HOT-MIX ASPHALT ROADWAY PAVEMENT AREAS THAT WILL REQUIRE CONCRETE OR HOT-MIX SURFACE REMOVAL. THE ENGINEER WILL MARK IN THE FIELD ALL STRUCTURES TO BE DONE UNDER THIS ITEM. SEE DETAIL SHEET FOR "FRAMES AND LIDS ADJUSTMENT WITH MILLING."

## PRIME COAT

PRIME COAT MUST BE INSTALLED NO EARLIER THAN TWENTY-FOUR (24) HOURS PRIOR TO PLACEMENT OF HOT-MIX ASPHALT. NOTIFICATION SHALL BE GIVEN TO THE ENGINEER 48 HOURS PRIOR TO PLACEMENT.

## FIELD OFFICE

THE CONTRACTOR WILL NOT BE ALLOWED TO SET UP A YARD OR FIELD OFFICE ON STATE OR VILLAGE PROPERTY WITHOUT WRITTEN PERMISSION FROM THE DEPARTMENT OR THE VILLAGE.

## BARRICADES

THE CONTRACTOR SHALL PROVIDE AND INSTALL TWO (2) WEIGHTED SANDBAGS ON EACH TYPE I OR TYPE II BARRICADE USED, ONE (1) WEIGHTED SANDBAG ACROSS EACH BOTTOM RAIL

## BUTT JOINTS

BUTT JOINT WILL BE INSTALLED AT THE ENDS OF ALL RESURFACING (WHERE RESURFACING MEETS EXISTING PAVEMENT). IN ACCORDANCE WITH THE "BUTT JOINT AND HMA TAPER DETAILS" SHEET INCLUDED IN THE PLANS, UNLESS OTHERWISE SPECIFIED.

## MILLED PAVEMENT OPEN TO TRAFFIC

WHEN MILLED PAVEMENT IS OPEN TO TRAFFIC THE MAXIMUM GRADE DIFFERENTIAL BETWEEN PASSES OF THE MILLING MACHINE SHALL NOT EXCEED 1-1/2 INCHES (40 MM) WHERE THE SPEED LIMIT IS 45 MPH (80 KM/H) OR LESS AND 1 INCH (25 MM) WHERE THE SPEED LIMIT IS GREATER THAN 45 MPH (80 KM/H). WITH WRITTEN APPROVAL FROM THE ENGINEER, A MAXIMUM GRADE DIFFERENTIAL OF 3 INCHES (75 MM) MAY BE ALLOWED IF THE EDGE OF THE MILLING IS SLOPED A MINIMUM 1:3 (V:H)

## HOT-MIX ASPHALT PAVING OPERATIONS

THE HOT-MIX ASPHALT LEVELING BINDER SHALL BE PLACED IN TWO (2) PASSES, WITH A COLD JOINT LOCATED WITHIN THREE INCHES (3") OF THE EXISTING CROWN OF THE PAVEMENT. THE CONTRACTOR WILL BE REQUIRED TO SCHEDULE HIS OPERATIONS SO THAT NO SECTIONS OF PAVEMENT ALONG THE CROWN WILL HAVE A COLD JOINT OVERNIGHT.

THE HOT-MIX ASPHALT SURFACE COURSE SHALL BE PLACED IN TWO (2) PASSES WITH A COLD JOINT LOCATED AT THE EXISTING CROWN OF THE PAVEMENT. THE CONTRACTOR WILL BE REQUIRED TO SCHEDULE HIS OPERATIONS SO THAT NO SECTIONS OF PAVEMENT ALONG THE CROWN WILL HAVE A COLD JOINT OVERNIGHT.

## PAVEMENT PATCHING

LOCATIONS OF PATCHES WILL BE DETERMINED IN FIELD BY ENGINEER.

Drawing file: W:\Projects\74009075 - Tholcher Ave\INDEX.dwg Jun 02, 2009 - 11:13am



9103 Riverside Blvd  
Washington, Illinois 61545-2782  
Phone: 708.965.4300  
Fax: 708.965.2525

USER NAME	DESIGNED	CH	REVISED
	DRAWN	MK	REVISED
PLOT SCALE	CHECKED	CH	REVISED
PLOT DATE	DATE	4-21-09	REVISED

**STATE OF ILLINOIS**  
**DEPARTMENT OF TRANSPORTATION**

**GENERAL NOTES**

SCALE: NONE SHEET NO. OF SHEETS STA. TO STA.

F.A.U. RTE.	SECTION	COUNTY	TOTAL SHEETS	SHEET NO.
2753	09-00089-00-RS	COOK	15	3
CONTRACT NO. 63215			ILLINOIS FED. AID PROJECT ARA-9003(349)	

E.H.E. PROJECT NO. 740-09-07501

## SUMMARY OF QUANTITIES

CODE	PAY ITEM DESCRIPTION	UNIT	1000 TOTAL QUANTITY	1000 100% FEDERAL 0% LOCAL
21101615	TOPSOIL FURNISH AND PLACE, 4"	SQYD	70	70
25200110	SODDING, SALT TOLERANT	SQYD	70	70
25200200	SUPPLEMENTAL WATERING	UNIT	50	50
40600100	BITUMINOUS MATERIALS (PRIME COAT)	GAL	1,200	1,200
40600300	AGGREGATE (PRIME COAT)	TON	25	25
40600895	CONSTRUCTING TEST STRIP	EACH	2	3
40600982	HOT-MIX ASPHALT SURFACE REMOVAL - BUTT JOINT	SQYD	85	85
40603335	HOT-MIX ASPHALT SURFACE COURSE, MIX D, N50	TON	1,400	1,400
42400200	PORTLAND CEMENT CONCRETE SIDEWALK, 5 INCH	SQFT	50	50
⊛ 42400800	DETECTABLE WARNINGS	SQFT	15	15
⊛ 44000160	HOT-MIX ASPHALT SURFACE REMOVAL, 2 3/4"	SQYD	11,700	11,700
⊛ 44000600	SIDEWALK REMOVAL	SQFT	50	50
⊛ 44001700	COMBINATION CONCRETE CURB AND GUTTER REMOVAL AND REPLACEMENT	FOOT	200	200
⊛ 44201765	CLASS D PATCHES, TYPE II, 10 INCH	SQYD	300	300
⊛ 44201771	CLASS D PATCHES, TYPE IV, 10 INCH	SQYD	300	300
⊛ 60257900	MANHOLES TO BE RECONSTRUCTED	EACH	4	4
60300305	FRAMES AND LIDS TO BE ADJUSTED	EACH	8	8
⊛ 60300310	FRAMES AND LIDS TO BE ADJUSTED (SPECIAL)	EACH	19	19
⊛ 60406000	FRAMES AND LIDS, TYPE 1, OPEN LID	EACH	5	5
⊛ 60406100	FRAMES AND LIDS, TYPE 1, CLOSED LID	EACH	5	5
67100100	MOBILIZATION	L SUM	1	1
⊛ 70101700	TRAFFIC CONTROL AND PROTECTION	L SUM	1	1
⊛ 70300100	SHORT TERM PAVEMENT MARKING	FOOT	500	500
★ 78000100	THERMOPLASTIC PAVEMENT MARKING - LETTERS AND SYMBOLS	SQFT	110	110
★ 78000200	THERMOPLASTIC PAVEMENT MARKING - LINE 4"	FOOT	4,500	4,500
★ 78000400	THERMOPLASTIC PAVEMENT MARKING - LINE 6"	FOOT	825	825
★ 78000650	THERMOPLASTIC PAVEMENT MARKING - LINE 24"	FOOT	80	80
⊛ ★ 88600600	DETECTOR LOOP REPLACEMENT	FOOT	200	200
⊛ X4067107	POLYMERIZED LEVELING BINDER (MACHINE METHOD), IL 4.75, N50	TON	700	700

★ DENOTES SPECIALTY ITEM  
 ⊛ DENOTES SPECIAL PROVISION HAS BEEN PROVIDED

Drawing file: W:\Projects\74009075 - Thatcher Ave\Summary.dwg Jun 02, 2009 - 11:15am

**HANCOCK ENGINEERING**  
 Civil Engineers  
 Municipal Consultants  
 Established 1911

USER NAME	DESIGNED <b>CH</b>	REVISED
	DRAWN <b>MK</b>	REVISED
PLOT SCALE	CHECKED <b>CH</b>	REVISED
PLOT DATE	DATE <b>4-21-09</b>	REVISED

**STATE OF ILLINOIS  
 DEPARTMENT OF TRANSPORTATION**

<b>SUMMARY OF QUANTITIES</b>			
SCALE:	SHEET NO.	OF SHEETS	STA. TO STA.

F.A.U. RTE.	SECTION	COUNTY	TOTAL SHEETS	SHEET NO.
2753	09-00089-00-RS	COOK	15	4
FED. ROAD DIST. NO. 1 ILLINOIS FED. AID PROJECT			CONTRACT NO. 63215	
ARA-9003(349)			E.H.E. PROJECT NO. 740-09-07501	

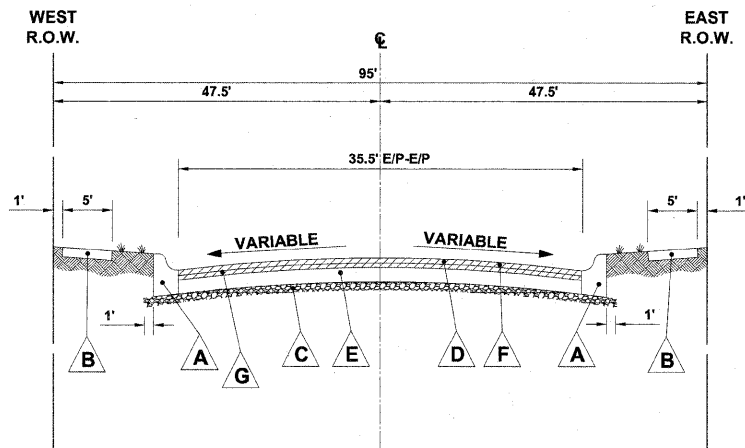

**EXISTING TYPICAL CROSS SECTION  
THATCHER AVENUE  
(STATION 0+00 TO STATION 1+15)**

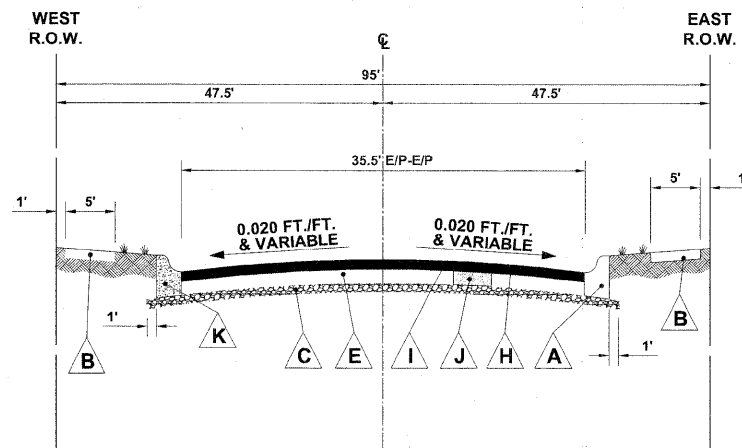

**PROPOSED TYPICAL CROSS SECTION  
THATCHER AVENUE  
(STATION 0+00 TO STATION 1+15)**

**LEGEND OF SYMBOLS**

SYMBOL	DESCRIPTION
A	EXISTING COMBINATION CONCRETE CURB & GUTTER, TYPE B-6.12
B	EXISTING PORTLAND CEMENT CONCRETE SIDEWALK
C	EXISTING SUB-BASE GRANULAR MATERIAL, 4" AND VARIABLE
D	EXISTING HOT-MIX ASPHALT SURFACE COURSE, 2"
E	EXISTING CONCRETE BASE COURSE
F	PROPOSED HOT-MIX ASPHALT SURFACE REMOVAL, 2 1/2"
G	EXISTING HOT-MIX ASPHALT BINDER COURSE, 1" & VARIABLE
H	PROPOSED POLYMERIZED LEVELING BINDER (MACHINE METHOD), IL 4.75, N50, 1"
I	PROPOSED HOT-MIX ASPHALT SURFACE COURSE, MIX D, N50, 2"
J	PROPOSED CLASS D PATCHES, 10"
K	PROPOSED INTERMITTENT COMBINATION CONCRETE CURB & GUTTER REMOVAL & REPLACEMENT

NOTE: PATCHING TO BE DONE AFTER PAVEMENT IS MILLED  
**HOT-MIX ASPHALT (HMA) MIXTURE REQUIREMENTS**

ITEM	A C TYPE	VOIDS
HOT-MIX ASPHALT SURFACE COURSE, MIX D, N50, (IL - 9.5 mm)	PG 64 -22	4% @ 50 GYR.
POLYMERIZED LEVELING BINDER (MACHINE METHOD), IL 4.75, N50	SBS/SBR PG 76 -28/ -22	4% @ 50 GYR.
CLASS D PATCHES (HMA BINDER, IL - 19 mm), 10"	PG 64 - 22 *	4% @ 70 GYR.

THE UNIT WEIGHT USED TO CALCULATE ALL HMA SURFACE COURSE IS 112 LBS/SQYD/IN.

\*WHEN RAP EXCEEDS 20%, THE NEW ASPHALT BINDER IN THE MIX SHALL BE PG 58.

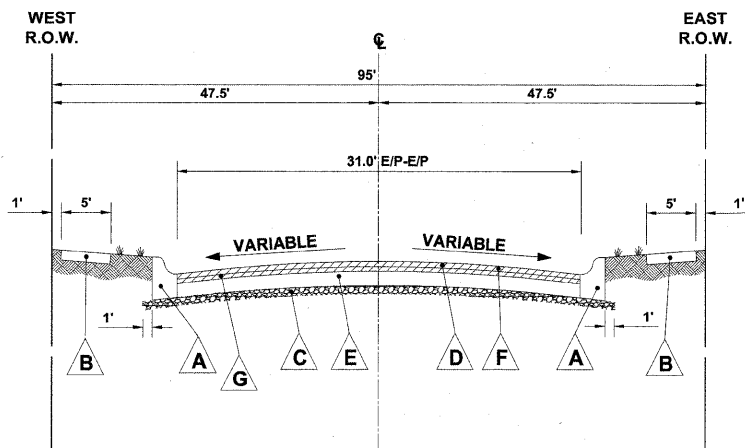

**EXISTING TYPICAL CROSS SECTION  
THATCHER AVENUE  
(STATION 1+15 TO STATION 23+10)**

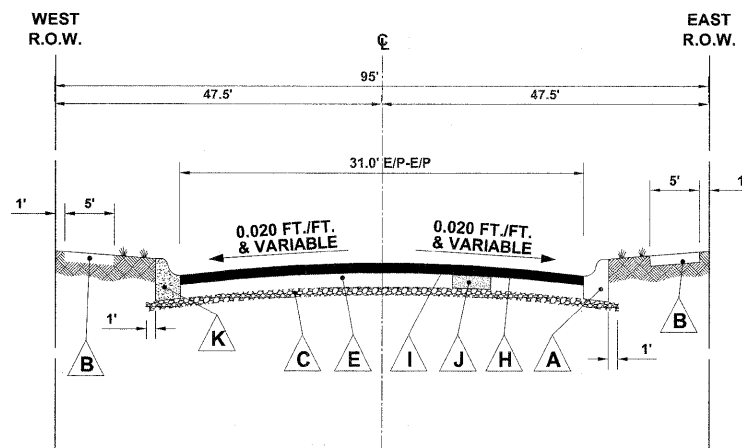

**PROPOSED TYPICAL CROSS SECTION  
THATCHER AVENUE  
(STATION 1+15 TO STATION 23+10)**

Drawing file: W:\Projects\74009075 - Thatcher Ave\TYPESEC.dwg Jun 02, 2009 - 11:03 am



9100 Riverfront Blvd  
Westchester, IL 60591-2700  
Phone: 708.944.0200  
Fax: 708.944.0222

USER NAME	DESIGNED	CH	REVISED
	DRAWN	MK	REVISED
PLOT SCALE	CHECKED	CH	REVISED
PLOT DATE	DATE	4-21-09	REVISED

**STATE OF ILLINOIS  
DEPARTMENT OF TRANSPORTATION**

**EXISTING AND PROPOSED  
TYPICAL CROSS SECTIONS**

SCALE: NONE SHEET NO. OF SHEETS STA. TO STA.

F.A.U. RTE.	SECTION	COUNTY	TOTAL SHEETS	SHEET NO.
2753	09-00089-00-RS	COOK	15	5
CONTRACT NO. 63215			ILLINOIS FED. AID PROJECT ARA-9003(349)	

E.H.E. PROJECT NO. 740-09-07501

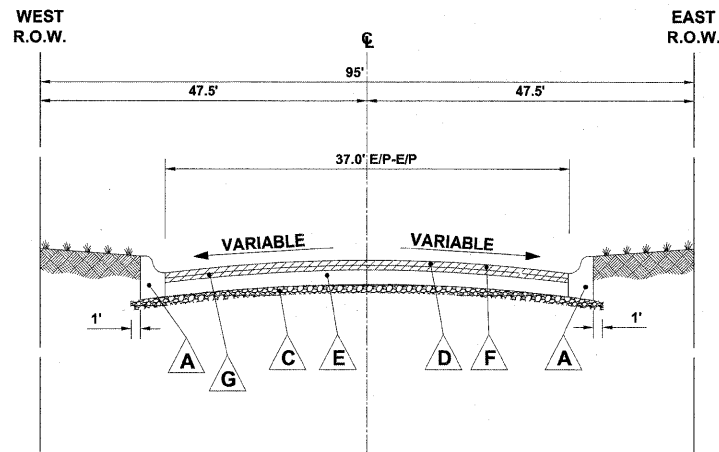

**EXISTING TYPICAL CROSS SECTION  
THATCHER AVENUE**  
(STATION 23+10 TO STATION 24+75)

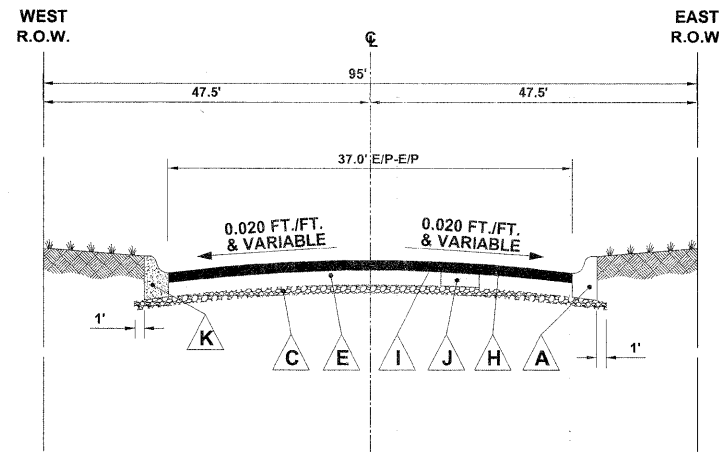

**PROPOSED TYPICAL CROSS SECTION  
THATCHER AVENUE**  
(STATION 23+10 TO STATION 24+75)

**LEGEND OF SYMBOLS**

SYMBOL	DESCRIPTION
A	EXISTING COMBINATION CONCRETE CURB & GUTTER, TYPE B-6.12
B	EXISTING PORTLAND CEMENT CONCRETE SIDEWALK
C	EXISTING SUB-BASE GRANULAR MATERIAL, 4" AND VARIABLE
D	EXISTING HOT-MIX ASPHALT SURFACE COURSE, 2"
E	EXISTING CONCRETE BASE COURSE
F	PROPOSED HOT-MIX ASPHALT SURFACE REMOVAL, 2 3/4"
G	EXISTING HOT-MIX ASPHALT BINDER COURSE, 1" & VARIABLE
H	PROPOSED POLYMERIZED LEVELING BINDER (MACHINE METHOD), IL 4.75, N50, 1"
I	PROPOSED HOT-MIX ASPHALT SURFACE COURSE, MIX D, N50, 2"
J	PROPOSED CLASS D PATCHES, 10"
K	PROPOSED INTERMITTENT COMBINATION CONCRETE CURB & GUTTER REMOVAL & REPLACEMENT

Drawing file: W:\Projects\74008075 - Thatcher Ave\TYPSEC.dwg Jun 02, 2009 - 11:00am



953 Riverside Road  
Webster, Illinois 60594-2706  
Phone: 708-965-8800  
Fax: 708-965-2322

USER NAME	DESIGNED <b>CH</b>	REVISED
	DRAWN <b>MK</b>	REVISED
PLOT SCALE <b>NONE</b>	CHECKED <b>CH</b>	REVISED
PLOT DATE	DATE <b>4-21-09</b>	REVISED

**STATE OF ILLINOIS  
DEPARTMENT OF TRANSPORTATION**

**EXISTING AND PROPOSED  
TYPICAL CROSS SECTIONS**

SCALE: **NONE** SHEET NO. OF SHEETS STA. TO STA.

F.A.U. RTE:	SECTION	COUNTY	TOTAL SHEETS	SHEET NO.
2753	09-00089-00-RS	COOK	15	6
FED. ROAD DIST. NO. 1 ILLINOIS FED. AID PROJECT			CONTRACT NO. 63215	
ARA-9003(349)			E.H.E. PROJECT NO. 740-09-07501	

**M.W.R.D.G.C. GENERAL NOTES**

1. THE MWRD SEWER SYSTEMS SECTION FIELD OFFICE MUST BE NOTIFIED AT LEAST TWO (2) WORKING DAYS PRIOR TO THE COMMENCEMENT OF WORK AT (708) 588-4055.
2. ELEVATION DATUM IS U.S.G.S.
3. ALL FLOOR DRAINS SHALL DISCHARGE TO THE SANITARY SEWER SYSTEM.
4. ALL DOWNSPOUTS AND FOOTING DRAINS SHALL DISCHARGE INTO THE STORM SEWER SYSTEM.
5. ALL PVC SEWER PIPE SHALL BE SDR 26. ALL PVC SEWER PIPE JOINTS SHALL CONFORM TO ASTM D-3139 FOR PVC PIPE 12" IN DIAMETER OR LESS. ALL PVC SEWER PIPE JOINTS SHALL CONFORM TO ASTM D-3212 FOR PVC PIPE 15" IN DIAMETER OR MORE. ALL PVC SEWER PIPE 12" IN DIAMETER OR LESS SHALL CONFORM TO ASTM D-2241 (WATER QUALITY PIPE). ALL PVC SEWER PIPE 15" IN DIAMETER OR MORE SHALL CONFORM TO ASTM D-3034.
6. ALL D.I.P. STORM, COMBINED AND SANITARY SEWER PIPE JOINTS SHALL CONFORM TO ANSI A-21.11. ALL D.I.P. SEWER PIPE SHALL CONFORM TO ASTM A-21.51. ALL D.I.P. SEWER PIPE SHALL BE CLASS 52.
7. ALL SANITARY, COMBINED, AND STORM SEWER CONSTRUCTION IN COMBINED SEWER AREAS, REQUIRES STONE BEDDING 1/4" TO 1" IN SIZE, WITH A MINIMUM THICKNESS EQUAL TO 1/4 THE OUTSIDE DIAMETER OF THE SEWER PIPE, BUT NOT LESS THAN FOUR INCHES (4") NOR MORE THAN EIGHT INCHES (8"). MATERIAL SHALL BE CA-11 OR CA-13 AND SHALL BE EXTENDED AT LEAST 12" ABOVE THE TOP OF THE PIPE.
8. "BAND SEAL" OR SIMILAR FLEXIBLE-TYPE COUPLINGS SHALL BE USED IN THE CONNECTION OF SEWER PIPE OF DISSIMILAR MATERIALS.
9. WHEN CONNECTING TO AN EXISTING SEWER MAIN BY MEANS OTHER THAN AN EXISTING WYE, TEE, OR AN EXISTING MANHOLE, ONE OF THE FOLLOWING METHODS SHALL BE USED:
  - a) CIRCULAR SAW-CUT OF SEWER MAIN BY MECHANICAL CORING MACHINE, AND PROPER INSTALLATION OF HUB-WYE SADDLE OR HUB-TEE SADDLE, IN ACCORDANCE WITH THE MANUFACTURER'S RECOMMENDATIONS.
  - b) REMOVE AN ENTIRE SECTION OF PIPE (BREAKING ONLY THE TOP OF ONE BELL) AND REPLACE WITH A WYE OR TEE BRANCH SECTION. AFTER THE WYE OR TEE BRANCH IS INSERTED, CONCRETE SHALL BE PLACED OVER THE BROKEN AREA TO A MINIMUM THICKNESS OF 4" AND TO A DIMENSION OF 8" IN ALL DIRECTIONS.
  - c) USING PIPE CUTTER, NEATLY AND ACCURATELY CUT OUT DESIRED LENGTH OF PIPE FOR INSERTION OF PROPER FITTING. USE "BAND SEAL" OR SIMILAR COUPLINGS TO HOLD FIRMLY IN PLACE. FOLLOW MANUFACTURER'S RECOMMENDATIONS FOR THE INSTALLATION.
10. WHEREVER A SEWER CROSSES UNDER A WATER MAIN, THE MINIMUM VERTICAL DISTANCE FROM THE TOP OF THE SEWER TO THE BOTTOM OF THE WATER MAIN SHALL BE 18 INCHES. FURTHERMORE, A MINIMUM HORIZONTAL DISTANCE OF 10 FEET BETWEEN SANITARY/COMBINED SEWERS AND WATER MAINS SHALL BE MAINTAINED UNLESS: THE SEWER IS LAID IN A SEPARATE TRENCH, KEEPING A MINIMUM 18" VERTICAL SEPARATION; OR THE SEWER IS LAID IN THE SAME TRENCH WITH THE WATER MAIN LOCATED AT THE OPPOSITE SIDE ON A BENCH OF UNDISTURBED EARTH, KEEPING A MINIMUM 18" VERTICAL SEPARATION. IF EITHER THE VERTICAL OR HORIZONTAL DISTANCES DESCRIBED ABOVE CANNOT BE MAINTAINED, OR THE SEWER CROSSES ABOVE THE WATER MAIN, THE SEWER SHALL BE CONSTRUCTED TO WATER MAIN STANDARDS.
11. ALL SANITARY MANHOLES, (AND STORM MANHOLES IN COMBINED SEWER AREAS), SHALL HAVE A MINIMUM INSIDE DIAMETER OF 48 INCHES, AND SHALL BE PRE-CAST REINFORCED CONCRETE.
12. ALL ABANDONED SEWERS SHALL BE PLUGGED AT BOTH ENDS WITH A MINIMUM OF TWO (2) FEET LONG, NON-SHRINK CONCRETE/MORTAR PLUG.
13. ALL INLET AND OUTLET PIPES OF SANITARY SEWER MANHOLES AND OTHER UNDERGROUND STRUCTURES (AND IN COMBINED SEWER AREAS, ALSO ALL COMBINED STORM SEWER MANHOLES, CATCH BASINS, INLETS, AND UNDERGROUND DETENTION STORAGE STRUCTURES) SHALL BE JOINED WITH WATERTIGHT FLEXIBLE RUBBER CONNECTORS CONFORMING TO A.S.T.M. C-443 & C-923 WITH STAINLESS STEEL BANDS.
14. THE MAXIMUM ALLOWABLE INFILTRATION OR EXFILTRATION IS 100 GAL/DAY/MILE/INCH DIA OF THE SEWER PIPE.

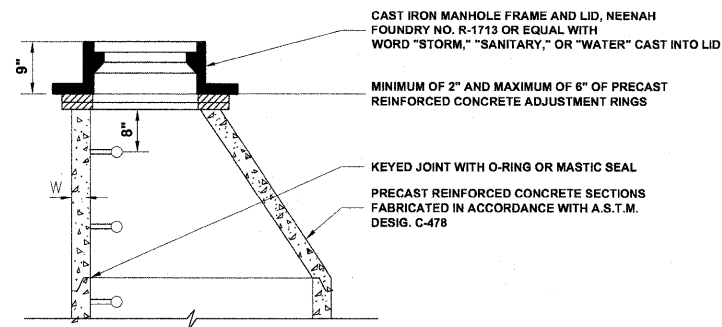

**STRUCTURE RECONSTRUCTION DETAIL**

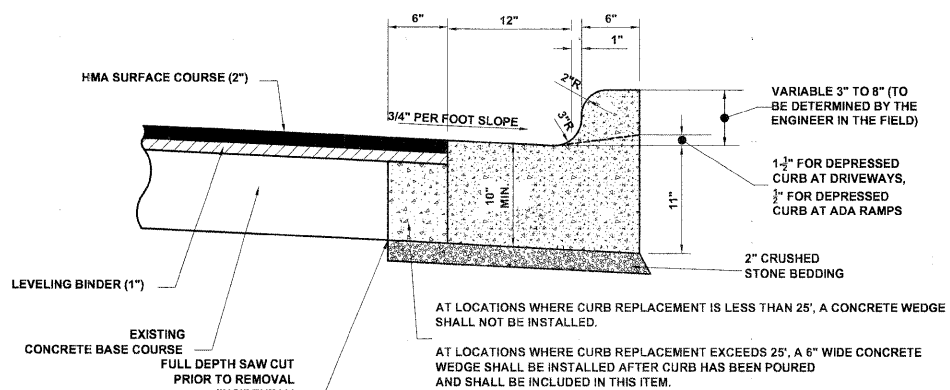

**COMBINATION CONCRETE CURB & GUTTER  
TYPE B-6.12 (MODIFIED)**

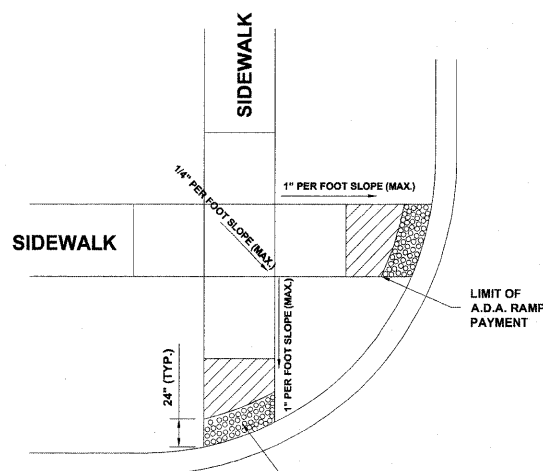

**A.D.A. RAMP DETAIL**

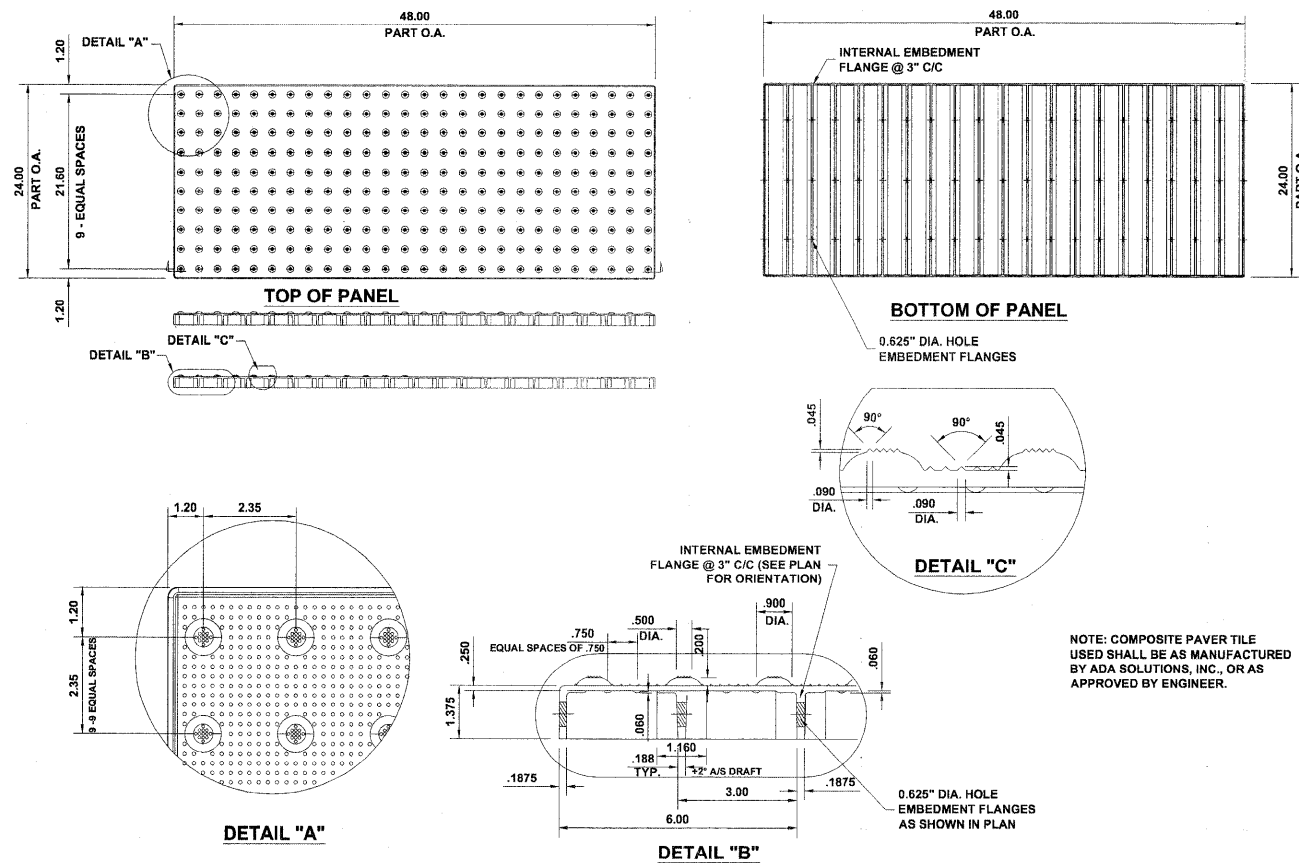

**CAST-IN-PLACE COMPOSITE PAVER TILE  
FOR DETECTABLE WARNING**

USER NAME	DESIGNED	CH	REVISED
PLOT SCALE	DRAWN	MK	REVISED
PLOT DATE	CHECKED	CH	REVISED
	DATE	4-21-09	REVISED

F.A.U. RTE.	SECTION	COUNTY	TOTAL SHEETS	SHEET NO.
2753	09-00089-00-RS	COOK	15	7
CONTRACT NO.			63215	
FED. ROAD DIST. NO. 1 ILLINOIS FED. AID PROJECT			ARA-9003(349)	
E.H.E. PROJECT NO. 740-09-07501				

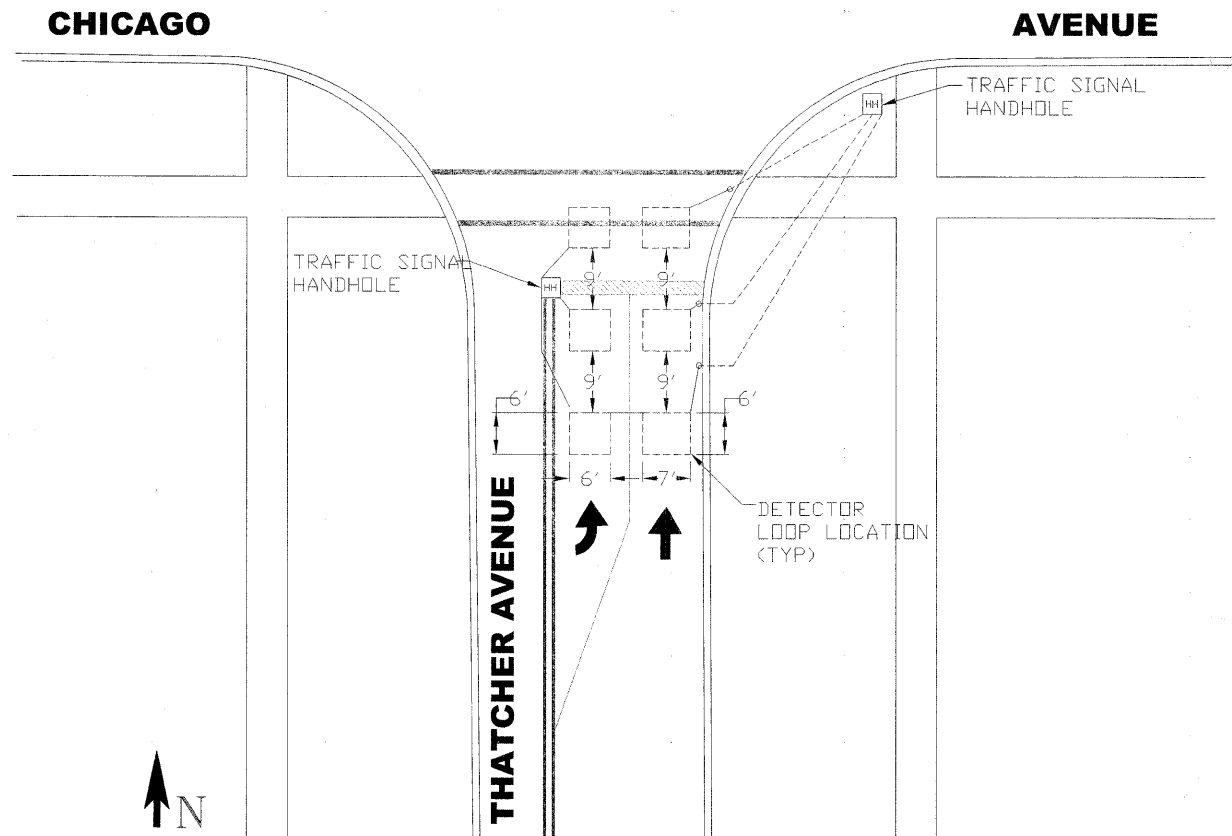

THATCHER AND CHICAGO INTERSECTION  
TRAFFIC SIGNAL DETECTOR LOOP LOCATIONS

NOT TO SCALE

Drawing file: W:\Projects\74009075 - Thatcher Ave Detail.dwg Jun 02, 2009 11:02am

**HANCOCK ENGINEERING**  
Civil Engineers  
Municipal Consultants  
Established 1911

9913 Grandview Blvd  
Waukegan, IL 60087-2180  
Phone: 708.948.0300  
Fax: 708.948.0312

USER NAME	DESIGNED <b>CH</b>	REVISED
	DRAWN <b>MK</b>	REVISED
PLOT SCALE	CHECKED <b>CH</b>	REVISED
PLOT DATE	DATE <b>4-21-09</b>	REVISED

**STATE OF ILLINOIS  
DEPARTMENT OF TRANSPORTATION**

**TRAFFIC SIGNAL DETECTOR LOOP REPLACEMENT PLAN**

SCALE: **NONE** SHEET NO.  OF  SHEETS STA.  TO STA.

F.A.U. RTE.	SECTION	COUNTY	TOTAL SHEETS	SHEET NO.
2753	09-00089-00-RS	COOK	15	8
CONTRACT NO. 63215			FED. ROAD DIST. NO. 1 ILLINOIS FED. AID PROJECT ARA-9003(349)	

E.H.E. PROJECT NO. 740-09-07501



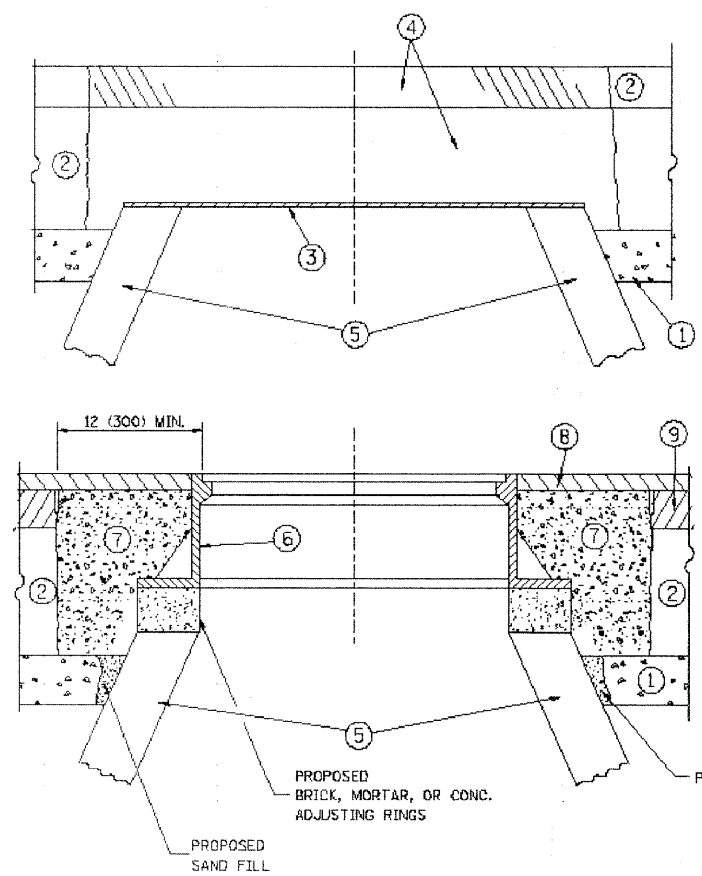

**CONSTRUCTION PROCEDURES**

- STAGE 1 (BEFORE PAVEMENT MILLING)**
- A) REMOVE A MINIMUM OF 12 (300) OF THE PAVEMENT FROM AROUND THE STRUCTURE.
  - B) REMOVE THE EXISTING FRAME AND LID FROM THE STRUCTURE.
  - C) COVER THE STRUCTURE OPENING WITH A 36 (900) DIAMETER METAL PLATE.
  - D) BACKFILL WITH CRUSHED STONE AND A MINIMUM 1 1/2 (40) THICK HMA SURFACE MIX APPROVED BY THE ENGINEER.
- STAGE 2 (AFTER PAVEMENT MILLING)**
- A) REMOVE THE HMA SURFACE MIX AND CRUSHED STONE.
  - B) INSTALL THE FRAME AND LID; ADJUST THE FRAME TO ITS FINAL SURFACE ELEVATION.
  - C) THE SURROUNDING SPACE SHALL BE FILLED WITH CLASS S1 CONCRETE, OR HMA SURFACE COURSE OR HMA BINDER COURSE TO THE ELEVATION OF THE SURFACE OF THE EXISTING BASE COURSE OR THE BINDER COURSE.

THE PROCEDURE EXPLAINED ABOVE SHALL CONFORM TO THE APPLICABLE PORTIONS OF SECTIONS 353, 406, 602, AND 603 OF THE STANDARD SPECIFICATIONS.

**LEGEND**

- ① SUB-BASE GRANULAR MATERIAL
- ② EXISTING PAVEMENT
- ③ 36 (900) DIAMETER METAL PLATE
- ④ PROPOSED CRUSHED STONE AND HMA SURFACE MIX
- ⑤ EXISTING STRUCTURE
- ⑥ FRAME AND LID (SEE NOTES)
- ⑦ CLASS S1 CONCRETE, HMA SURFACE COURSE OR HMA BINDER COURSE
- ⑧ PROPOSED HMA SURFACE COURSE
- ⑨ PROPOSED HMA BINDER COURSE

**NOTES:**

EXISTING BROKEN FRAMES AND LIDS SHALL BE REMOVED AND DISPOSED OF BY THE CONTRACTOR AND SHALL BE REPLACED AS DIRECTED BY THE ENGINEER. REPLACEMENT FRAMES AND LIDS WILL BE PAID FOR IN ACCORDANCE WITH ARTICLE 109.04 OF THE STANDARD SPECIFICATIONS UNLESS A SEPARATE PAY ITEM HAS BEEN PROVIDED.

IF THE EXISTING LIDS ARE OPEN, THE FRAME WILL BE ADJUSTED TO THE ELEVATION OF THE MILLED PAVEMENT SURFACE PRIOR TO THE MILLING OPERATION. THE FRAME WILL NOT BE REMOVED AND COVERED BY THE METAL PLATE.

CITY OF CHICAGO CASTINGS ARE THE PROPERTY OF THE CITY AND THE CONTRACTOR SHALL NOTIFY THE CITY FOR REMOVAL AND DISPOSITION OF THE CASTINGS.

THE METAL PLATE USED TO COVER THE STRUCTURE SHALL REMAIN THE PROPERTY OF THE CONTRACTOR.

WHEN STRUCTURES ARE TO BE ADJUSTED OR RECONSTRUCTED, THE LOWERING AND RAISING OF THE FRAMES AND LIDS WILL NOT BE PAID FOR SEPARATELY BUT WILL BE INCLUDED IN THE COST OF THE CORRESPONDING PAY ITEM.

**LOCATION OF STRUCTURES:**

THE CONTRACTOR WILL BE REQUIRED TO KEEP A RECORD OF THE LOCATIONS OF THE BURIED STRUCTURES ACCORDING TO THE STATION AND DISTANCE LEFT OR RIGHT OF THE CENTERLINE OF PAVEMENT. UPON COMPLETION OF THE WORK, THE CONTRACTOR WILL DELIVER THE RECORD TO THE ENGINEER.

**BASIS OF PAYMENT:** THIS WORK WILL BE PAID FOR AT THE CONTRACT UNIT PRICE PER EACH FOR "FRAMES AND LIDS TO BE ADJUSTED, SPECIAL" NEW FRAMES AND LIDS, WHEN SPECIFIED, WILL BE PAID FOR SEPARATELY.

**DETAILS FOR FRAMES AND LIDS ADJUSTMENT WITH MILLING**

ALL DIMENSIONS ARE IN INCHES (MILLIMETERS) UNLESS OTHERWISE SHOWN

Drawing file: W:\Projects\74009075 - Thatcher Ave\MARKINGS.dgn Jun 02, 2009 - 10:56am

FILE NAME =	USER NAME = geglernobt	DESIGNED - R. SHAH	REVISED - R. SHAH 03-10-95
W:\data\74009075\bd08.dgn		DRAWN -	REVISED - A. ABBAS 03-21-97
PLOT SCALE = 50.0000 / 1 IN	CHECKED -	REVISED - R. WIEDEMAN 05-14-04	
PLOT DATE = 1/4/2008	DATE - 10-25-94	REVISED - R. BORO 01-01-07	

**STATE OF ILLINOIS  
DEPARTMENT OF TRANSPORTATION**

<b>DETAILS FOR FRAMES AND LIDS ADJUSTMENT WITH MILLING</b>			
SCALE: NONE	SHEET NO. 1 OF 1 SHEETS	STA.	TO STA.

F.A. RTE.	SECTION	COUNTY	TOTAL SHEETS	SHEET NO.
2753	09-00089-00-RS	COOK	15	9
<b>B0000-03 (BD-8)</b>		CONTRACT NO. 63215		
FED. ROAD DIST. NO. 1 ILLINOIS FED. AID PROJECT ARA-9003 (349)				

VARIABLE - TO MEET EXISTING DIMENSIONS AND FIELD CONDITIONS (SEE NOTE ②)

PROP. CONC. CURB OR CURB AND GUTTER REPLACEMENT IN ACCORDANCE WITH STATE STANDARD 606001. (SEE NOTE ②)

SAW CUT FULL DEPTH - INCLUDED IN THE COST OF SIDEWALK, DRIVEWAY OR MEDIAN SURFACE REMOVAL PAY ITEM.

SEE STATE STANDARD 606001

18" (450) MAX.

EXISTING OR PROPOSED HMA SURFACE (IF APPLICABLE)

1/4" (5) \*\*

EXISTING SIDEWALK, DRIVEWAY, MEDIAN SURFACE OR GROUND.

PROPOSED SIDEWALK, DRIVEWAY PAVEMENT, MEDIAN SURFACE OR SALT TOLERANT SOD AND TOP SOIL, 4" (100) SOD RESTORATION (SEE NOTE ①).

EXISTING CONCRETE PAVEMENT, CONCRETE BASE COURSE OR FLEXIBLE PAVEMENT

3" (75) MIN.

SUITABLE BACKFILL MATERIAL (INCLUDED IN THE COST OF CURB OR CURB AND GUTTER REMOVAL AND REPLACEMENT)

PROPOSED 3/4" (20) PREFORMED EXPANSION JOINT AT CONCRETE SIDEWALKS, DRIVEWAYS, AND MEDIANS. (INCLUDED IN THE COST OF CURB OR CURB AND GUTTER REMOVAL AND REPLACEMENT.)

\* 3" (75) MINIMUM FROM TOP AND BOTTOM OF THE CONCRETE PAVEMENT OR BASE COURSE.

\*\* IF THE FINAL SURFACE OF THE PAVEMENT IS CONCRETE, THE GUTTER IS TO BE FLUSH WITH THE PAVEMENT.

NOTE: ① SIDEWALK, DRIVEWAY PAVEMENT OR MEDIAN SURFACE SHALL BE SIMILAR TO THE MATERIAL BEING REMOVED AND WILL BE PAID FOR SEPARATELY.

SALT TOLERANT SOD AND TOP SOIL, 4" (100) RESTORATION WILL NOT BE PAID FOR SEPARATELY, BUT SHALL BE INCLUDED IN THE COST OF CURB OR CURB AND GUTTER REMOVAL AND REPLACEMENT.

② CURB OR CURB AND GUTTER REPLACEMENT SHALL MATCH THE SHAPE OF THE EXISTING CURB OR CURB AND GUTTER UNLESS OTHERWISE SPECIFIED.

③ FOR CURB OR CURB AND GUTTER REMOVAL AND REPLACEMENT ADJACENT TO FLEXIBLE PAVEMENT DELETE EPOXY COATED TIE BARS.

④ LONGITUDINAL BARS, IF ENCOUNTERED IN THE EXISTING CURB OR CURB AND GUTTER, ARE NOT TO BE REPLACED. CUTTING AND REMOVING LONGITUDINAL BARS SHALL BE INCLUDED IN THE COST OF CURB OR CURB AND GUTTER REMOVAL AND REPLACEMENT.

⑤ THE COST OF HMA SURFACE REMOVAL IN THE EXISTING GUTTER FLAG SHALL BE INCLUDED IN THE COST OF THE CURB AND GUTTER REMOVAL AND REPLACEMENT.

⑥ THE REMOVAL AND REPLACEMENT OF THE EXISTING CURB OR CURB AND GUTTER SHALL BE DONE IN ACCORDANCE WITH THE APPLICABLE PORTIONS OF SECTION 440 AND 606 OF THE STANDARD SPECIFICATIONS.

⑦ THE LOCATIONS OF REMOVAL AND REPLACEMENT OF EXISTING CURB OR CURB AND GUTTER SHALL BE DETERMINED BY THE RESIDENT ENGINEER AT THE TIME OF CONSTRUCTION.

UNSUITABLE SUB-BASE MATERIAL TO BE REMOVED, IF DIRECTED BY THE ENGINEER, SHALL BE REPLACED WITH EITHER SUB-BASE GRANULAR MATERIAL, TYPE B OR ADDITIONAL THICKNESS OF CONCRETE.

REMOVAL AND REPLACEMENT 4" (100) OR LESS IS INCLUDED IN THE COST OF CURB OR CURB AND GUTTER REMOVAL AND REPLACEMENT.

REMOVAL AND REPLACEMENT IN EXCESS OF 4" (100) WILL BE PAID FOR IN ACCORDANCE WITH ARTICLE 109.04 OF THE STANDARD SPECIFICATIONS.

PROPOSED #6 (20) EPOXY COATED TIE BARS 24" (600) LONG AT 24" (600) CENTERS WILL NOT BE PAID FOR SEPARATELY. DELETE EPOXY COATED TIE BARS IF EXISTING TIE BARS ARE USABLE AS DETERMINED BY THE ENGINEER. (SEE NOTE ③).

**BASIS OF PAYMENT:**

THIS WORK WILL BE PAID FOR AT THE CONTRACT UNIT PRICE PER FOOT (METER) FOR "CURB REMOVAL AND REPLACEMENT" OR "COMBINATION CONCRETE CURB AND GUTTER REMOVAL AND REPLACEMENT".

# CURB OR CURB AND GUTTER REMOVAL AND REPLACEMENT

ALL DIMENSIONS ARE IN INCHES (MILLIMETERS) UNLESS OTHERWISE SHOWN.

Drawing file: W:\Projects\74009075 - Thatcher Ave\MARKINGS.dgn Jun 02, 2009 - 10:58am

FILE NAME = W:\distatd\22c34\bd24.dgn	USER NAME = geglancdt	DESIGNED - A. HOUSEH	REVISED - R. SHAH 10-03-96
		DRAWN -	REVISED - A. ABBAS 03-21-97
		PLOT SCALE = 60,000 / 1 IN.	REVISED - M. GOMEZ 01-22-01
		PLOT DATE = 1/4/2008	REVISED - R. BORO 01-01-07

**STATE OF ILLINOIS  
DEPARTMENT OF TRANSPORTATION**

**CURB OR CURB AND GUTTER  
REMOVAL AND REPLACEMENT**

SCALE: NONE SHEET NO. 1 OF 1 SHEETS STA. TO STA.

F.A. RTE.	SECTION	COUNTY	TOTAL SHEETS	SHEET NO.
2753	09-00089-00-RS	COOK	15	10
BD000-06 (BD-24)			CONTRACT NO. 63215	
FED. ROAD DIST. NO. 1 ILLINOIS FED. AID PROJECT ARA-9003 (349)				

E.H.E. PROJECT NO. 740-09-07501

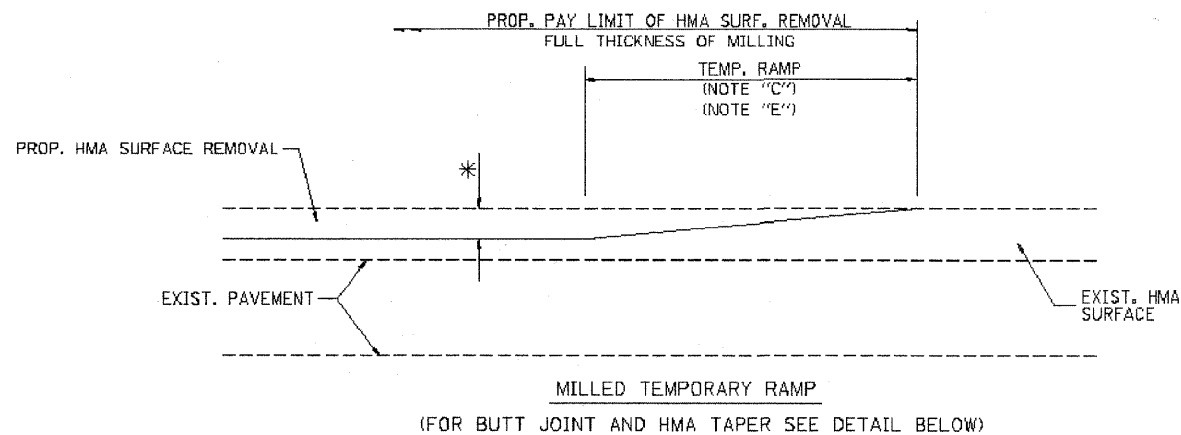

OPTION 1

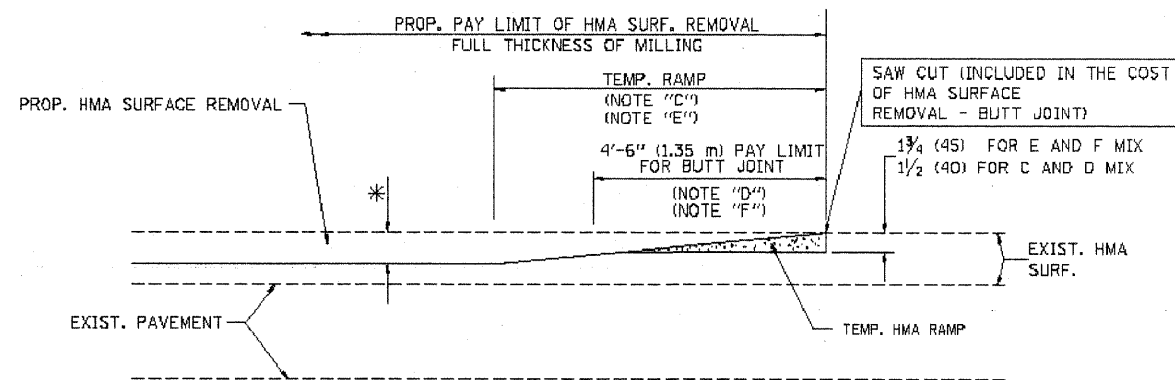

OPTION 2  
TYPICAL TEMPORARY RAMP

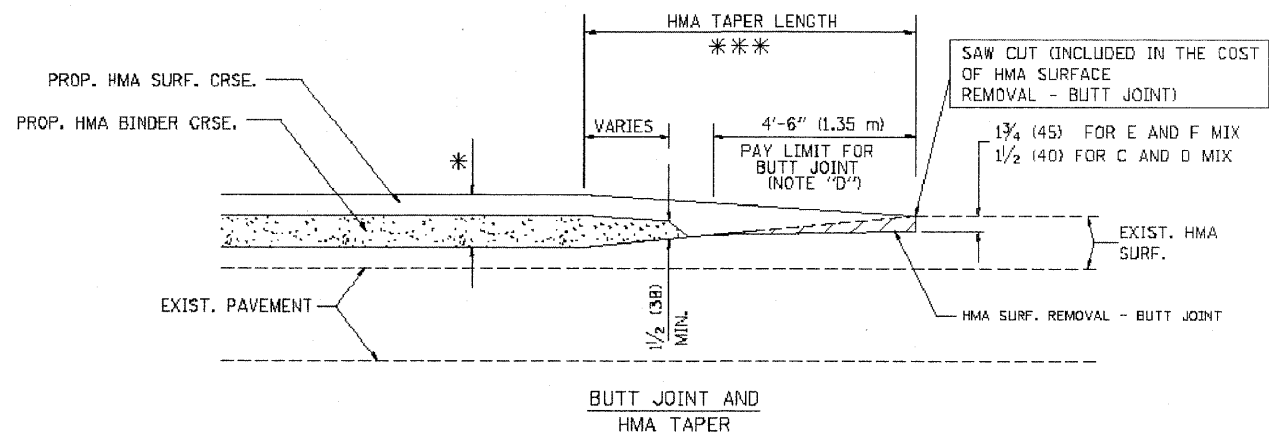

TYPICAL BUTT JOINT AND HMA TAPER  
FOR MILLING AND RESURFACING

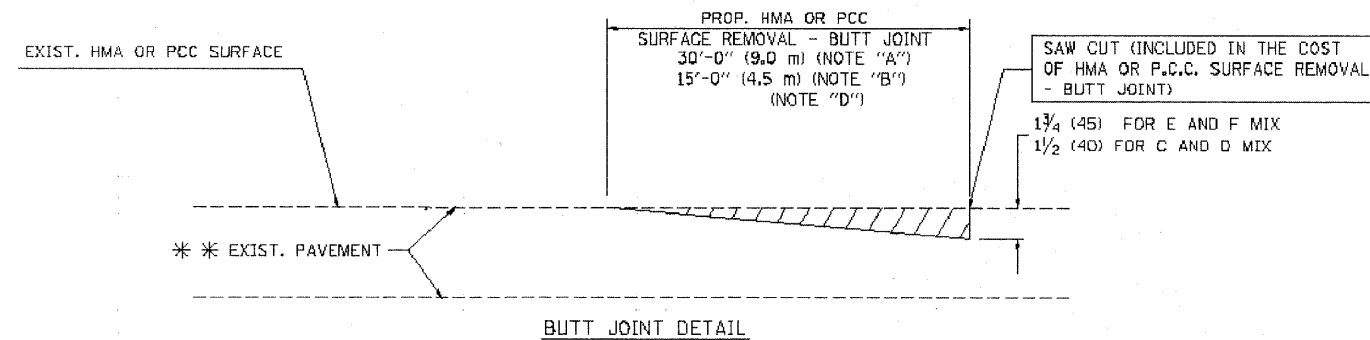

BUTT JOINT DETAIL

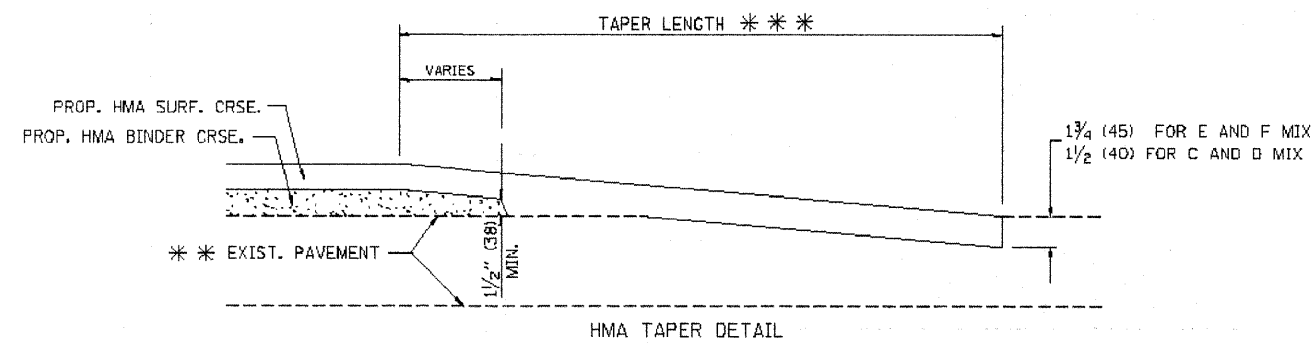

TYPICAL BUTT JOINT AND HMA TAPER  
FOR RESURFACING ONLY

\*\*\* PC CONCRETE, HMA OR HMA RESURFACED PAVEMENT.

NOTES

- A: MAINLINE ROADWAYS AND MAJOR SIDE ROADS.
  - B: MINOR SIDE ROADS.
  - C: THE TEMP. RAMP SHALL BE CONSTRUCTED IMMEDIATELY UPON REMOVAL OF THE EXISTING HMA SURFACE.
  - D: THE BUTT JOINT SHALL BE CONSTRUCTED IMMEDIATELY PRIOR TO PLACING THE PROPOSED HMA COURSES.
  - E: TAPER THE TEMP. RAMP AT A RATE OF 3'-0" (900 mm) PER 1 INCH (25 mm) OF MILLING THICKNESS.
  - F: INSTALLATION AND REMOVAL OF THE 4'-6" (1.35 m) TEMP. RAMP IS INCLUDED IN COST OF HMA SURFACE REMOVAL - BUTT JOINT
  - G: SEE ARTICLE 406.08 AND 406.14 OF THE STANDARD SPECIFICATIONS FOR "HMA AND/OR PCC SURFACE REMOVAL, BUTT JOINT".
- \* SEE TYPICAL SECTIONS FOR MILLING THICKNESS.
- \*\*\* 20'-0" (6.1 m) PER 1 (25) RESURFACING (NOTE "A")  
10'-0" (3.0 m) PER 1 (25) RESURFACING (NOTE "B")

BASIS OF PAYMENT:

THE BUTT JOINT WILL BE PAID FOR AT THE CONTRACT UNIT PRICE PER SQUARE YARD (SQUARE METER) FOR "HOT-MIX ASPHALT SURFACE REMOVAL - BUTT JOINT" OR FOR "PORTLAND CEMENT CONCRETE SURFACE REMOVAL - BUTT JOINT".

ALL DIMENSIONS ARE IN INCHES (MILLIMETERS) UNLESS OTHERWISE SHOWN.

Drawing file: W:\Projects\74009075 - Thatcher Ave\MARKINGS.dgn Jun 02, 2009 - 10:55am

FILE NAME = W:\dstart\22c34\bd92.dgn	USER NAME = geglendb	DESIGNED - M. DE YONG	REVISED - R. SHAH 10-25-94
		DRAWN -	REVISED - A. ABBAS 03-21-97
	PLOT SCALE = 50.0000' / IN.	CHECKED -	REVISED - M. GOMEZ 04-06-01
	PLOT DATE = 1/4/2008	DATE - 06-13-90	REVISED - R. BORO 01-01-07

STATE OF ILLINOIS  
DEPARTMENT OF TRANSPORTATION

BUTT JOINT AND  
HMA TAPER DETAILS

SCALE: NONE SHEET NO. 1 OF 1 SHEETS STA. TO STA.

F.A. RTE. 2753	SECTION 09-0089-00-RS	COUNTY COOK	TOTAL SHEETS 15	SHEET NO. 11
RD400-05 B032			CONTRACT NO. 63215	
FED. ROAD DIST. NO. 1 ILLINOIS FED. AID PROJECT ARA-9003 (349)				

E.H.E. PROJECT NO. 740-09-07501

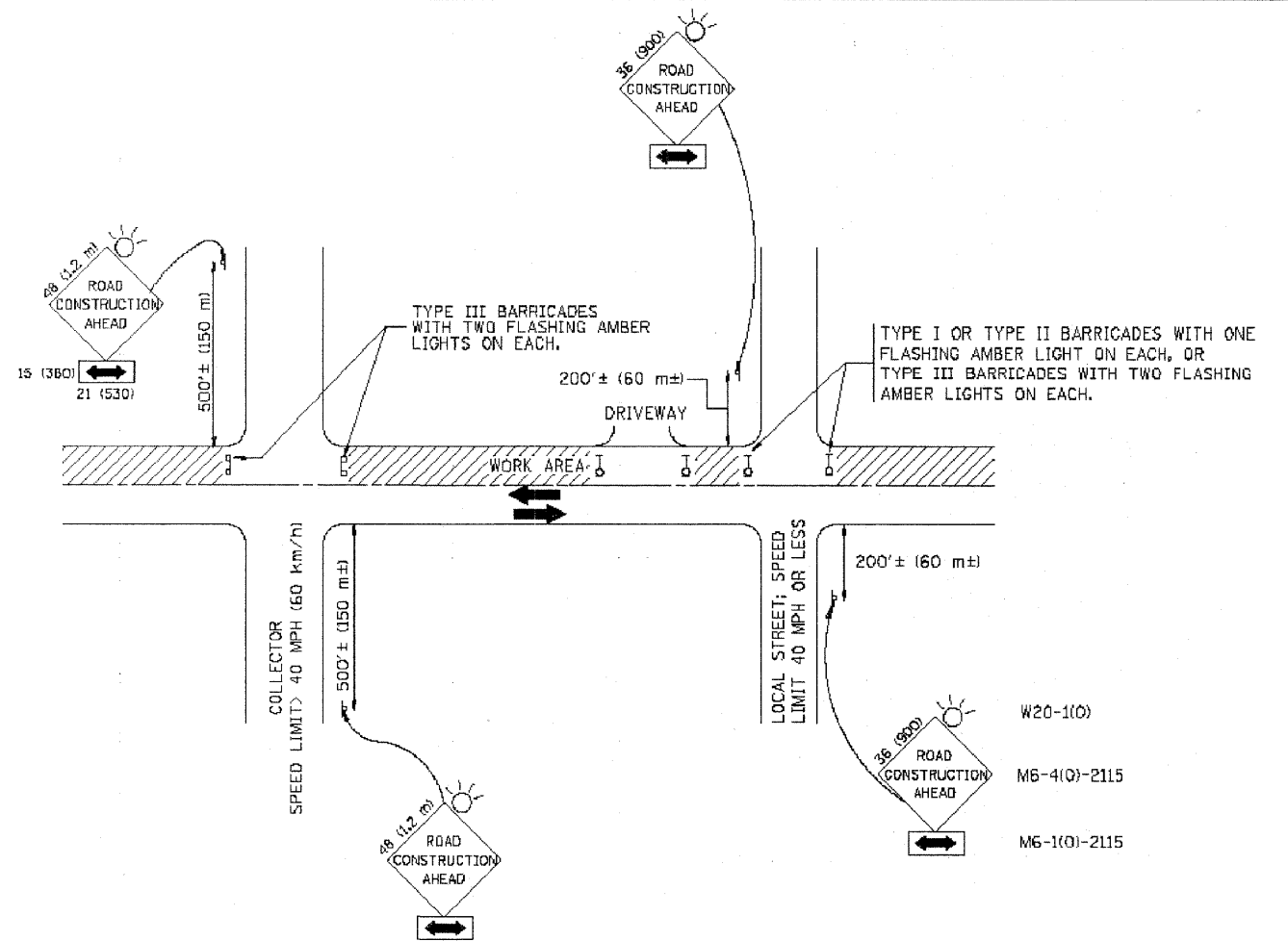

TRAFFIC CONTROL AND PROTECTION FOR SIDE ROADS, INTERSECTIONS, AND DRIVEWAYS

NOTES:

- A. FOR NO LANE RESTRICTION ON THE SIDE ROAD OR DRIVEWAYS
- SIDE ROAD WITH A SPEED LIMIT OF 40 MPH (60 km/h) OR LESS AS SHOWN ON THE DRAWING AND AS DIRECTED BY THE ENGINEER:
    - ONE **ROAD CONSTRUCTION AHEAD** SIGN 36 x 36 (900x900) WITH A FLASHER AND FLAG MOUNTED ON IT APPROXIMATELY 200' (60 m) IN ADVANCE OF THE MAIN ROUTE.
    - THE CLOSED PORTION OF THE MAIN ROUTE SHALL BE PROTECTED BY BLOCKING WITH TYPE I, TYPE II OR TYPE III BARRICADES, 1/3 OF THE CROSS SECTION OF THE CLOSED PORTION.
  - SIDE ROAD WITH A SPEED LIMIT GREATER THAN 40 MPH (60 km/h) AS SHOWN ON THE DRAWING AND AS DIRECTED BY THE ENGINEER:
    - ONE **ROAD CONSTRUCTION AHEAD** SIGN 48 x 48 (1.2 m x 1.2 m) WITH A FLASHER MOUNTED ON IT APPROXIMATELY 500' (150 m) IN ADVANCE OF THE MAIN ROUTE.
    - THE CLOSED PORTION OF THE MAIN ROUTE SHALL BE PROTECTED BY BLOCKING WITH TYPE III BARRICADES, 1/2 OF THE CROSS SECTION OF THE CLOSED PORTION.
  - WHEN THE SIDE ROAD LIES BETWEEN THE BEGINNING OF THE MAINLINE SIGNING AND THE WORK ZONE, A SINGLE HEADED ARROW (M6-1) SHALL BE USED IN LIEU OF THE DOUBLE HEADED ARROW (M6-4).
- B. FOR A LANE CLOSURE ON A SIDE ROAD OR DRIVEWAY:
- USE APPLICABLE PORTIONS OF THE TYPICAL APPLICATION OF TRAFFIC CONTROL DEVICES (STD. 701501, STD. 701505 OR THE APPROPRIATE STANDARD). THE SPACING OF SIGNS AND BARRICADES SHALL BE ADJUSTED FOR FIELD CONDITIONS AS DIRECTED BY THE ENGINEER. THE DIRECTIONAL ARROW SHALL BE COVERED OR REMOVED WHEN NO LONGER CONSISTENT WITH THE SIDE ROAD LANE CLOSURE.
- C. ADVANCE WARNING SIGNS ARE TO BE OMITTED ON DRIVEWAY UNLESS OTHERWISE NOTED.
- D. THE TRAFFIC CONTROL AND PROTECTION FOR SIDE ROADS, INTERSECTIONS, AND DRIVEWAYS SHALL BE INCIDENTAL TO THE COST OF SPECIFIED TRAFFIC CONTROL STANDARDS OR ITEMS.

All dimensions are in millimeters (Inches) unless otherwise shown.

Drawing file: W:\Projects\74009075 - Trotter Ave\MARKINGS.dgn Jun 02, 2009 - 10:54am

FILE NAME = W:\data\ref\22x34\ref.dgn	USER NAME = geglianobt	DESIGNED - LHA	REVISED - J. OBERLE 10-18-95
		DRAWN -	REVISED - A. HOUSEH 03-06-96
		CHECKED -	REVISED - A. HOUSEH 10-15-96
		DATE - 06-89	REVISED - T. RAMMACHER 01-06-00

STATE OF ILLINOIS  
DEPARTMENT OF TRANSPORTATION

TRAFFIC CONTROL AND PROTECTION FOR  
SIDE ROADS, INTERSECTIONS, AND DRIVEWAYS

SCALE: NONE SHEET NO. 1 OF 1 SHEETS STA. TO STA.

F.A. RTE.	SECTION	COUNTY	TOTAL SHEETS	SHEET NO.
2753	09-00089-00-RS	COOK	15	12
<b>TC-10</b>			CONTRACT NO. 63215	
FED. ROAD DIST. NO. 1 (ILLINOIS) FED. AID PROJECT ARA-9003 (349)				

E.H.E. PROJECT NO. 740-09-07501

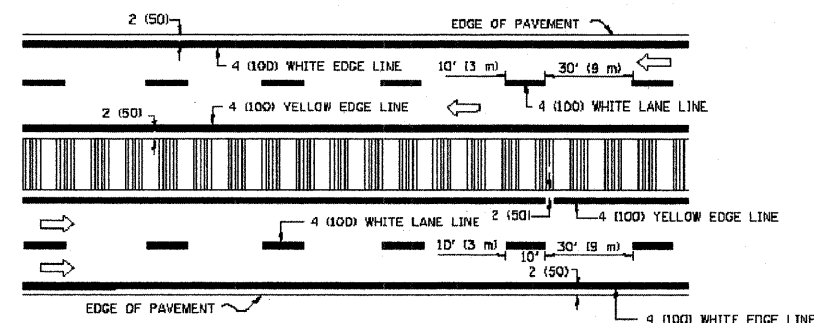
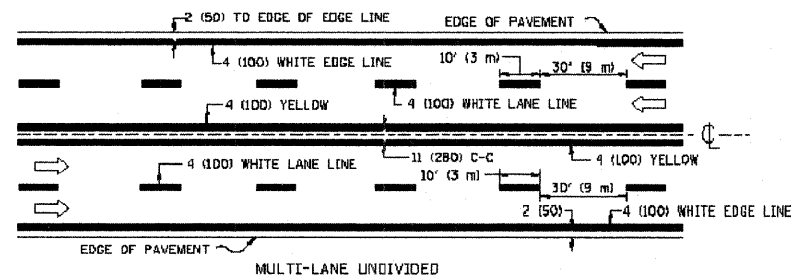
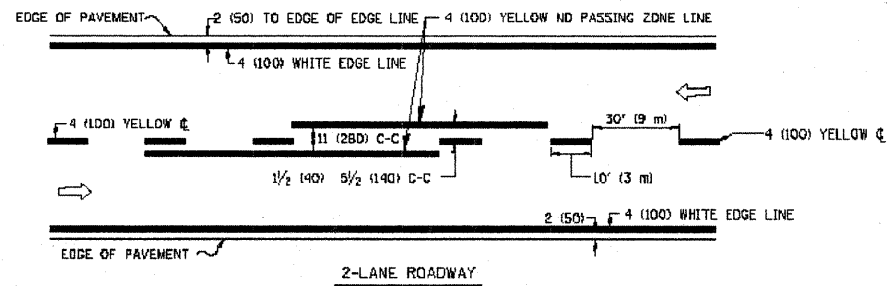

NOTE: MEDIANS WITH BARRIER CURB DO NOT REQUIRE AN EDGE LINE

**TYPICAL LANE AND EDGE LINE MARKING**

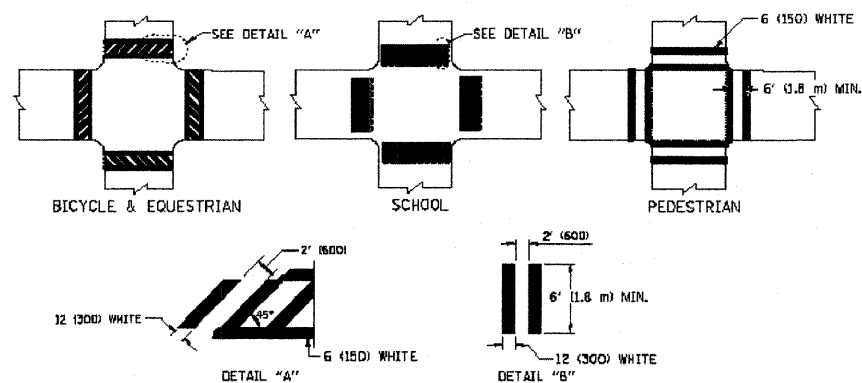

**TYPICAL CROSSWALK MARKING**

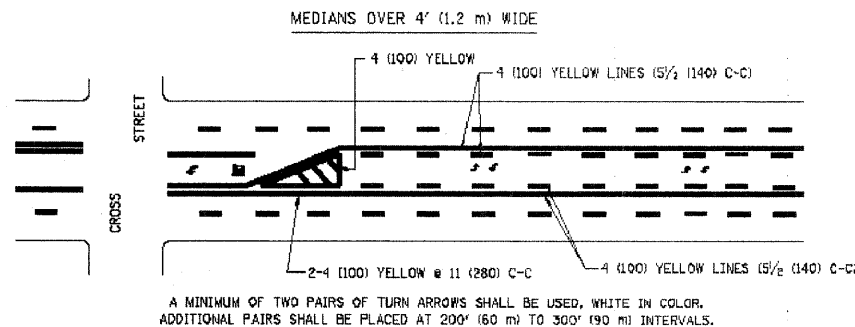
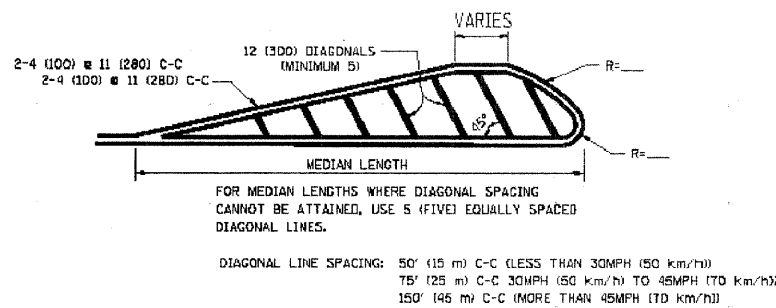
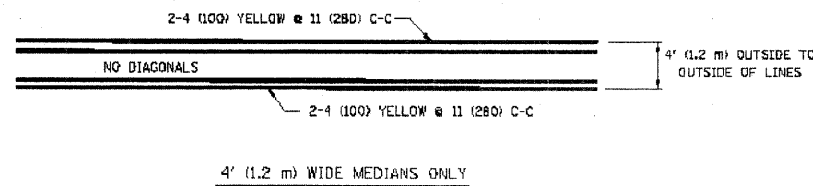

**TYPICAL PAINTED MEDIAN MARKING**

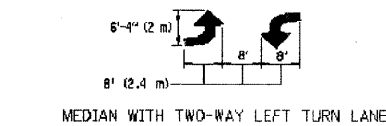

**TYPICAL TURN LANE MARKING**

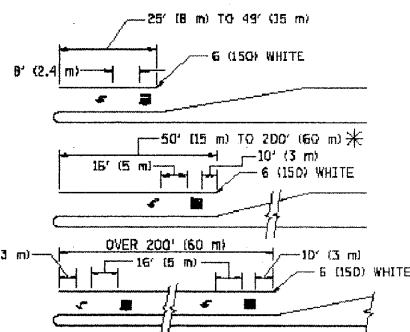

FULL SIZE LETTERS 6" (152 mm) AND ARROWS SHALL BE USED.  
 \* TURN LANES IN EXCESS OF 400' (122 m) IN LENGTH MAY HAVE AN ADDITIONAL SET OF ARROW - "ONLY" INSTALLED MIDWAY BETWEEN THE OTHER TWO SETS OF ARROW - "ONLY".

**TYPICAL TURN LANE MARKING**

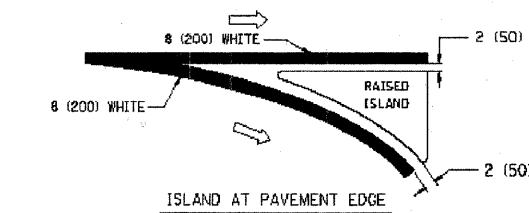
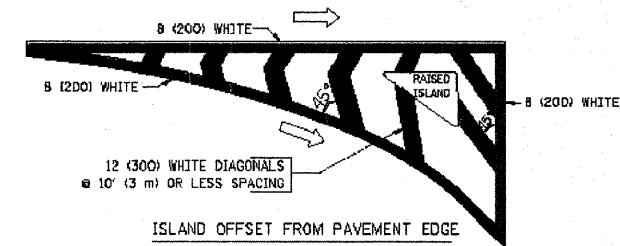

**TYPICAL ISLAND MARKING**

TYPE OF MARKING	WIDTH OF LINE	PATTERN	COLOR	SPACING / REMARKS
CENTERLINE ON 2 LANE PAVEMENT	4 (100)	SKIP-DASH	YELLOW	30' (9 m) LINE WITH 30' (9 m) SPACE
CENTERLINE ON MULTI-LANE UNDIVIDED PAVEMENT	2 @ 4 (100)	SOLID	YELLOW	11 (280) C-C
NO PASSING ZONE LINES FOR ONE DIRECTION FOR BOTH DIRECTIONS	4 (100) 2 @ 4 (100)	SOLID SOLID	YELLOW YELLOW	5/2 (140) C-C FROM SKIP-DASH CENTERLINE 11 (280) C-C OMIT SKIP-DASH CENTERLINE BETWEEN
LANE LINES	4 (100) 5 (125) ON FREEWAYS	SKIP-DASH SKIP-DASH	WHITE WHITE	10' (3 m) LINE WITH 30' (9 m) SPACE
DOTTED LINES (EXTENSIONS OF CENTER, LANE OR TURN LANE MARKINGS)	SAME AS LINE BEING EXTENDED	SKIP-DASH	SAME AS LINE BEING EXTENDED	2' (600) LINE WITH 6' (1.8 m) SPACE
EDGE LINES	4 (100)	SOLID	YELLOW-LEFT WHITE-RIGHT	OUTLINE MOUNTABLE MEDIANS IN YELLOW. EDGE LINES ARE NOT USED NEXT TO BARRIER CURB
TURN LANE MARKINGS	6 (150) LINE; FULL SIZE LETTERS & SYMBOLS (6" (152 mm))	SOLID	WHITE	SEE TYPICAL TURN LANE MARKING DETAIL
TWO WAY LEFT TURN MARKING	2 @ 4 (100) EACH DIRECTION 8' (2.4 m) LEFT ARROW	SKIP-DASH AND SOLID IN PAIRS	YELLOW WHITE	10' (3 m) LINE WITH 30' (9 m) SPACE FOR SKIP-DASH 5/2 (140) C-C BETWEEN SOLID LINE AND SKIP-DASH LINE SEE TYPICAL TWO-WAY LEFT TURN MARKING DETAIL
CROSSWALK LINES (PEDESTRIAN) A. DIAGONALS (BIKE & EQUESTRIAN) B. LONGITUDINAL BARS (SCHOOL)	2 @ 6 (150) 12 (300) @ 45° 12 (300) @ 90°	SOLID SOLID SOLID	WHITE WHITE WHITE	NOT LESS THAN 6' (1.8 m) APART 2' (600) APART 2' (600) APART SEE TYPICAL CROSSWALK MARKING DETAILS.
STOP LINES	24 (600)	SOLID	WHITE	PLACE 4' (1.2 m) IN ADVANCE OF AND PARALLEL TO CROSSWALK, IF PRESENT. OTHERWISE, PLACE AT DESIRED STOPPING POINT. PARALLEL TO CROSSROAD CENTERLINE, WHERE POSSIBLE
PAINTED MEDIANS	2 @ 4 (100) WITH 12 (300) DIAGONALS @ 45° NO DIAGONALS USED FOR 4' (1.2 m) WIDE MEDIANS	SOLID	YELLOW; TWO WAY TRAFFIC WHITE; ONE WAY TRAFFIC	11 (280) C-C FOR THE DOUBLE LINE SEE TYPICAL PAINTED MEDIAN MARKING.
DORE MARKING AND CHANNELIZING LINES	8 (200) WITH 12 (300) DIAGONALS @ 45°	SOLID	WHITE	DIAGONALS: 15' (4.5 m) C-C (LESS THAN 30MPH (50 km/h)) 20' (6 m) C-C 30MPH (50 km/h) TO 45MPH (70 km/h) 30' (9 m) C-C (OVER 45MPH (70 km/h))
RAILROAD CROSSING	24 (600) TRANSVERSE LINES; "RR" 15 (38 mm) LETTERS; 16 (400) LINE FOR "X"	SOLID	WHITE	SEE STATE STANDARD 780001 AREA OF: "R"=3.6 SQ. FT. (0.33 m²) EACH "X"=54.0 SQ. FT. (5.0 m²)
SHOULDER DIAGONALS	12 (300) @ 45°	SOLID	WHITE - RIGHT YELLOW - LEFT	50' (15 m) C-C (LESS THAN 30MPH (50 km/h)) 75' (25 m) C-C (30 MPH (50 km/h) TO 45MPH (70 km/h)) 150' (45 m) C-C (OVER 45MPH (70 km/h))

FOR FURTHER DETAILS ON PAVEMENT MARKING REFER TO STANDARD SPECIFICATIONS FOR ROAD AND BRIDGE CONSTRUCTION AND STATE STANDARD 780001.

All dimensions are in inches (millimeters) unless otherwise shown.

Drawing file: W:\Projects\74009075 - Thatcher Ave\MARKINGS.dwg Jun 02, 2009 - 10:49am

FILE NAME = W:\state\74009075\74009075.dwg	USER NAME = geglianobot	DESIGNED - EVERS	REVISED - T. RAMMACHER 10-27-94
PLOT SCALE = 58.0000' / IN.	CHECKED -	DRAWN -	REVISED - A. HOUSEH 10-09-96
PLOT DATE = 1/4/2008	DATE - 03-19-90	REVISOR -	REVISED - A. HOUSEH 10-17-96
			REVISED - T. RAMMACHER 01-06-00

**STATE OF ILLINOIS  
DEPARTMENT OF TRANSPORTATION**

**DISTRICT ONE  
TYPICAL PAVEMENT MARKINGS**

SCALE: NONE SHEET NO. 1 OF 1 SHEETS STA. TO STA.

F.A. RTE. 2753	SECTION 09-00089-00-RS	COUNTY COOK	TOTAL SHEETS 15	SHEET NO. 13
CONTRACT NO. TC-13			FED. ROAD DIST. NO. 1 [ILLINOIS] FED. AID PROJECT ARA-9003 (349)	

E.H.E. PROJECT NO. 740-09-07501

Drawing file: W:\Projects\74009075 - Thatcher Ave\MARKINGS.dwg Jun 02, 2009 - 10:39am

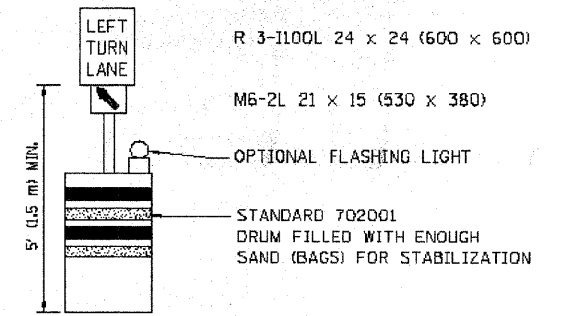
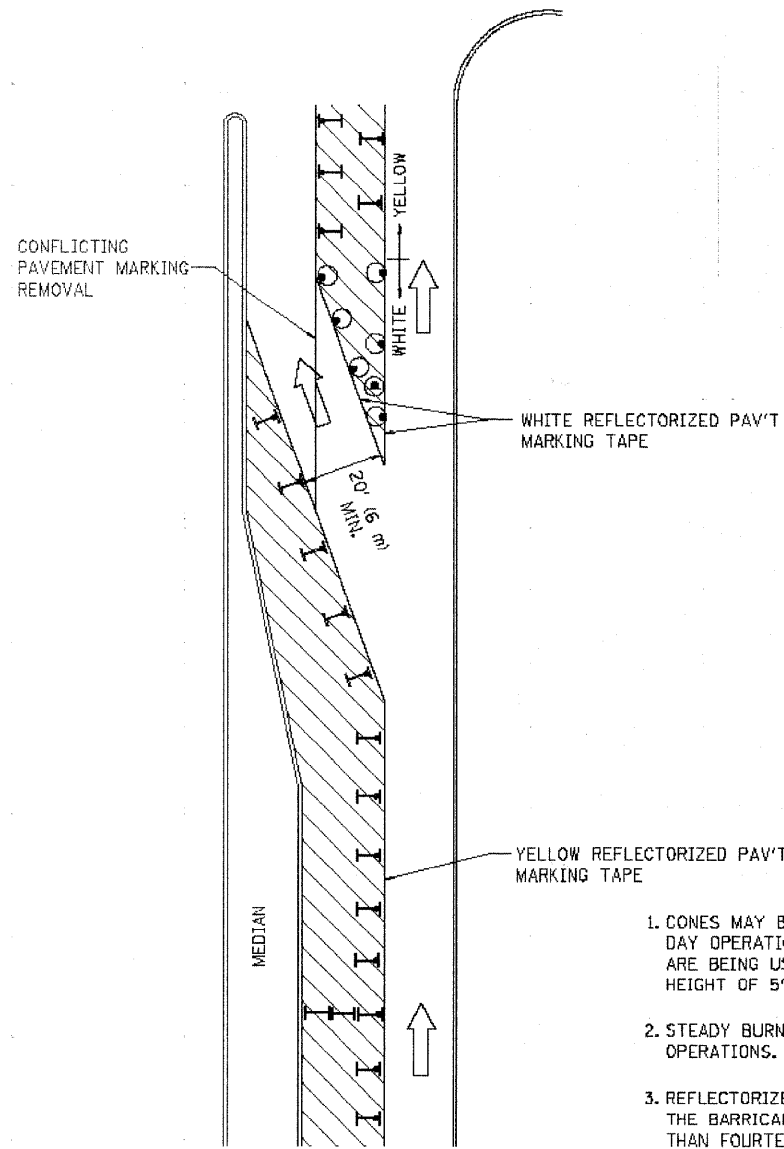

**GENERAL NOTES**

1. CONES MAY BE SUBSTITUTED FOR BARRICADES OR DRUMS AT HALF THE SPACING DURING DAY OPERATIONS. CONES SHALL BE A MINIMUM OF 28 (710) IN HEIGHT. WHEN CONES ARE BEING USED, THE "LEFT TURN LANE" SIGN MAY BE SKID MOUNTED AT A MINIMUM HEIGHT OF 5' (1.5 m).
2. STEADY BURNING LIGHTS WILL NOT BE REQUIRED ON BARRICADES OR DRUMS FOR DAY OPERATIONS. ALL LIGHTS SHALL BE MONODIRECTIONAL.
3. REFLECTORIZED TEMPORARY PAVEMENT MARKING TAPE SHALL BE PLACED THROUGHOUT THE BARRICADED AREA OF EACH TURN BAY WHERE THE CLOSURE TIME IS GREATER THAN FOURTEEN DAYS.
4. THIS APPLICATION ALSO APPLIES WHEN WORK IS BEING PERFORMED IN THE RIGHT LANE(S) AND THE RIGHT TURN BAY IS TO REMAIN OPEN. UNDER THIS CONDITION, "RIGHT TURN LANE" R3-100 24 x 24 (600 x 600) AND M6-2R 21 x 15 (530 x 380) SHALL BE USED.
5. THESE CONTROLS SHALL SUPPLEMENT MAINLINE TRAFFIC CONTROL FOR LANE CLOSURES.
6. LONGITUDINAL DIMENSIONS MAY BE ADJUSTED TO FIT FIELD CONDITIONS.
7. FORM BT 725 IS REQUIRED.
8. TRAFFIC CONTROL AND PROTECTION AT TURN BAYS (TO REMAIN OPEN TO TRAFFIC) SHALL BE INCLUDED IN THE COST SPECIFIED TRAFFIC CONTROL STANDARDS OR ITEMS.

All dimensions are in inches (millimeters) unless otherwise shown.

**LEGEND**

- WORK AREA
- LANE OPEN TO TRAFFIC
- TYPE I OR II BARRICADE WITH STEADY BURN LIGHT
- DRUM WITH STEADY BURN LIGHT
- DRUM WITH SIGN (WITH OPTIONAL FLASHING LIGHT) SEE DETAIL
- TYPE I OR II CHECK BARRICADE WITH FLASHING LIGHT

FILE NAME = W:\dxtatd\22x34\1c14.dgn	USER NAME = gaglianobt	DESIGNED - -	REVISED -T. RAMMACHER 09-08-94
		DRAWN - -	REVISED - A. HOUSEH 11-07-95
		CHECKED - -	REVISED - A. HOUSEH 10-12-96
		DATE - -	REVISED -T. RAMMACHER 01-06-00

**STATE OF ILLINOIS  
DEPARTMENT OF TRANSPORTATION**

TRAFFIC CONTROL AND PROTECTION AT TURN BAYS (TO REMAIN OPEN TO TRAFFIC)			
SCALE: NONE	SHEET NO. 1 OF 1 SHEETS	STA.	TO STA.

F.A. RTE. 2753	SECTION 09-00089-00-RS	COUNTY COOK	TOTAL SHEETS 15	SHEET NO. 14
TC-14			CONTRACT NO. 63215	
FED. ROAD DIST. NO. 1 (ILLINOIS) FED. AID PROJECT ARA-9003 (349)				

E.H.E. PROJECT NO. 740-09-07501

LOOPS NEXT TO SHOULDERS

PROVIDE A PAVEMENT REPLACEMENT NOTE WHICH SHOULD EQUAL 3' (900 mm) X WIDTH OF PAVED SHOULDER.

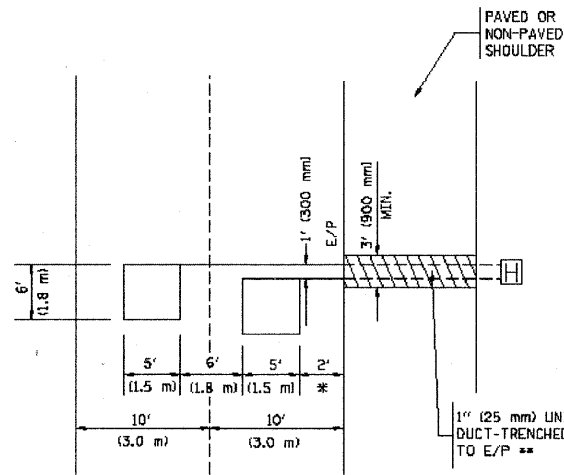

\* = (600 mm)

\*\* UNIT DUCT IS TO BE SHOWN ON PLAN SHEETS BUT SHALL NOT BE INCLUDED IN THE PAY ITEMS.

LEFT TURN LANES WITH MEDIANS  
VOLUME DENSITY ("FAR OUT" DETECTION)  
ON SAME APPROACH  
(PROTECTED / PERMITTED LEFT TURN PHASING)

HANDHOLE LOCATION MAY VARY DEPENDING ON GEOMETRICS AND DESIGN OF TRAFFIC SIGNALS. HEAVY-DUTY HANDHOLES TO BE USED WHEN THE MEDIAN IS MOUNTABLE. REFER TO STANDARD B14001 TO ENSURE THAT HANDHOLE FITS IN MEDIAN.

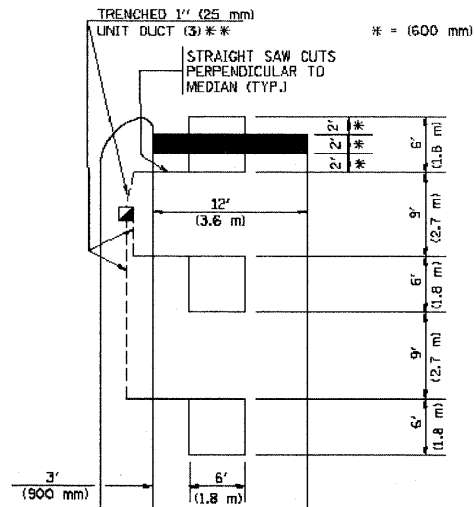

\*\* UNIT DUCT IS TO BE SHOWN ON PLAN SHEETS BUT SHALL NOT BE INCLUDED IN THE PAY ITEMS.

NOTE: DUAL LEFT TURNS NOT SHOWN REFER TO PLAN SHEET FOR DETECTOR LOOP REPLACEMENT

LEFT TURN LANES WITHOUT MEDIANS  
VOLUME DENSITY ("FAR OUT" DETECTION)  
ON SAME APPROACH  
(PROTECTED / PERMITTED LEFT TURN PHASING)

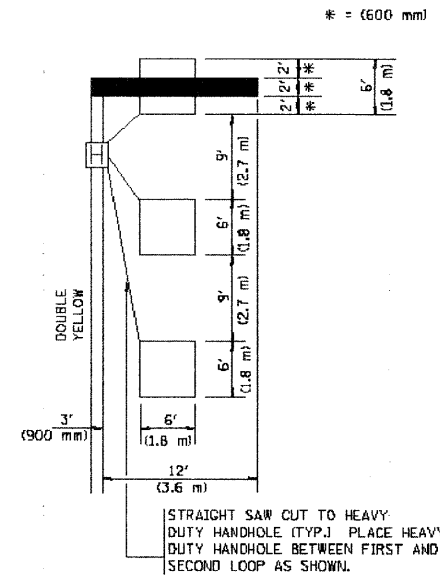

NOTE: DUAL LEFT TURNS NOT SHOWN REFER TO PLAN SHEET FOR DETECTOR LOOP REPLACEMENT

ARTERIAL-VOLUME DENSITY ("FAR OUT" DETECTION)  
CROSS STREET-VOLUME DENSITY ("FAR OUT" DETECTION)

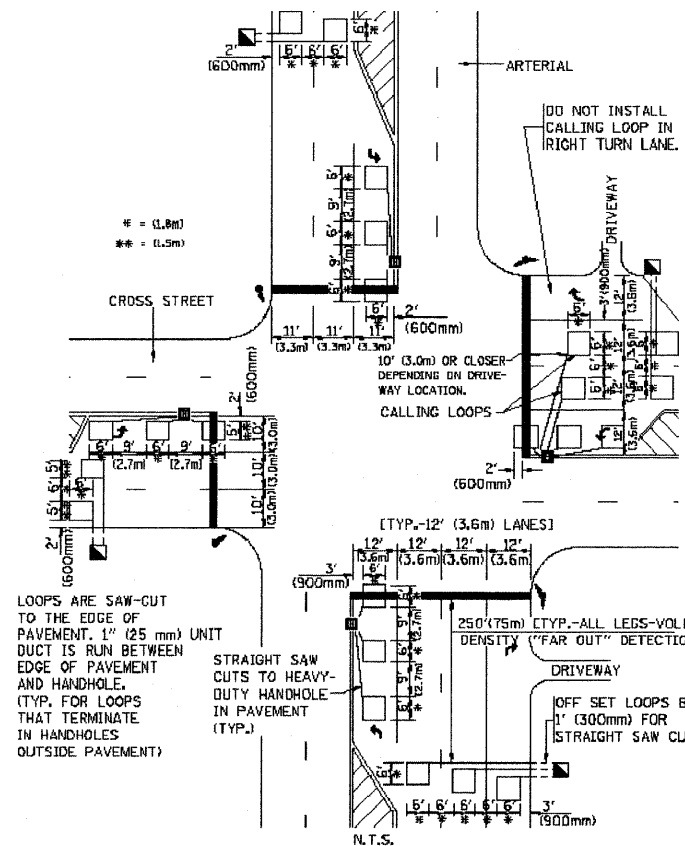

DETAIL 1  
N.T.S.

ARTERIAL-VOLUME DENSITY ("FAR OUT" DETECTION)  
CROSS STREET-NON VOLUME DENSITY ("UPTIGHT" PRESENCE DETECTION)

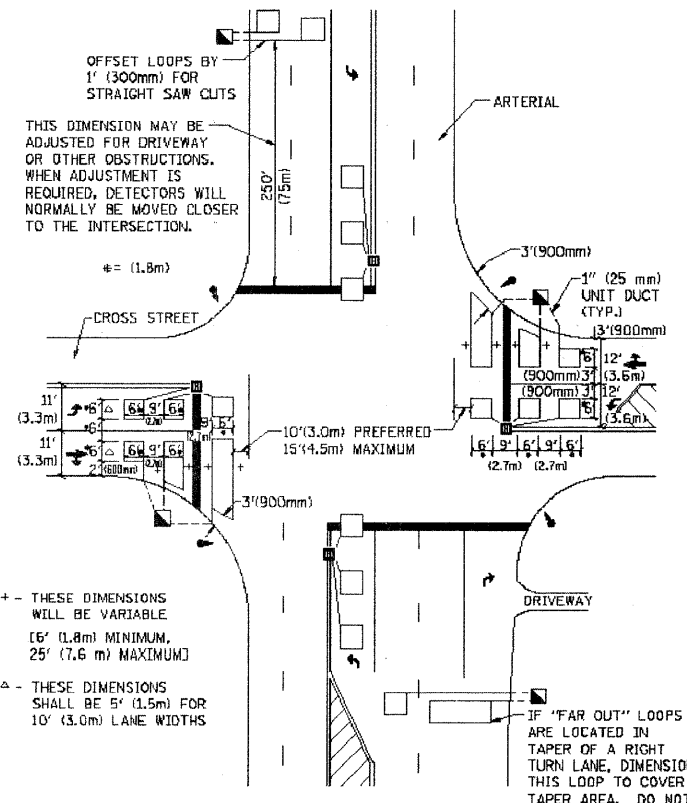

DETAIL 2  
N.T.S.

NOTES:

- VEHICLES LOOP DETECTORS
- \* ALL LEAD IN CABLE SHALL BE TWO CONDUCTOR NO. 14 TWISTED, SHIELDED.
- \* EACH DETECTOR LOOP SHALL HAVE ITS OWN SAW CUT FROM THE LOOP TO THE EDGE OF PAVEMENT OR TO A HANDHOLE IN THE PAVEMENT.
- \* EACH DETECTOR LOOP SHALL HAVE ITS OWN ONE INCH (25 mm) UNIT DUCT BETWEEN THE EDGE OF PAVEMENT AND THE FIRST HANDHOLE OR JUNCTION BOX. EACH UNIT DUCT RUN SHALL BE SHOWN ON THE PLANS BY THE DESIGNER, BUT SHALL NOT BE PAID FOR SEPARATELY. THIS ITEM IS INCIDENTAL TO THE PAY ITEM FOR DETECTOR LOOPS.
- \* ONE DIMENSION OF ALL DETECTOR LOOPS SHALL BE SIX FEET (1.8 m)
- \* EACH LANE OF NON-LOCKING, PRESENCE DETECTION AND EACH LANE OF A DOUBLE LEFT TURN LANE REQUIRES A SEPARATE INDUCTIVE LOOP DETECTOR AND LEAD IN CABLE.
- \* WHEN NON-LOCKING, PRESENCE DETECTION IS USED, MORE THAN ONE LOOP PER LANE IS REQUIRED BEHIND THE STOP BAR (i.e. 1-1/2, 1-3/4, 2).
- \* WHEN SYSTEM LOOPS ARE REQUIRED ON AN APPROACH OF AN INTERSECTION, THE LOOPS USED FOR VOLUME DENSITY AND INTERSECTION TIMING SHALL ALSO BE USED AS SYSTEM DETECTORS. EACH ONE OF THESE TYPE OF LOOPS REQUIRES A SEPARATE TWO CONDUCTOR NO. 14 TWISTED SHIELDED CABLE AND A SEPARATE INDUCTIVE LOOP DETECTOR WHEN NEW CONTROLLERS ARE UTILIZED. THE DESIGNER SHALL LABEL THESE TYPES OF LOOPS AS "INTERSECTION AND SAMPLING (SYSTEM) DETECTORS" ON THE SIGNAL LAYOUT, THE INTERCONNECT PLAN AND THE SYSTEM CABLE PLAN. WHEN AN EXISTING CONTROLLER IS UTILIZED FOR THIS TYPE OF DETECTION, THE PAY ITEM "INDUCTIVE LOOP DETECTOR WITH SYSTEM OUTPUT" SHOULD BE USED.

PLACEMENT OF DETECTORS

THE FOLLOWING FIGURES REPRESENT THE MOST COMMON DETECTOR LOOP LOCATIONS AND SIZES. ADJUSTMENTS WILL BE NECESSARY FOR SPECIFIC GEOMETRIC CONSIDERATIONS.

LOCATIONS AND DEMENSIONS OF DETECTOR LOOPS ARE REQUIRED ON ALL SIGNAL LAYOUT PLAN SHEETS.

"FAR OUT" DETECTION REFERS TO LOCKING, PRESENCE TYPE DETECTION LOCATED IN THRU LANES, RIGHT TURN LANES, AND RIGHT TURN LANE TAPER AREAS (IF APPLICABLE), USUALLY 250' (75 m) IN ADVANCE OF STOP BARS. "UPTIGHT" DETECTION REFERS TO NON-LOCKING PRESENCE TYPE DETECTION LOCATED IN ALL LANES AND 10'-15' (3.0 m-4.5 m) BEHIND THE CROSSING STREET'S EDGE OF PAVEMENT EXTENDED.

NOTE:

ALL DETAILS AND NOTES SHOWN ARE FROM THE I.D.O.T. DISTRICT 1 TRAFFIC SIGNAL DESIGN GUIDELINES DATED JANUARY 1995

THIS DRAWING HAS BEEN PREPARED TO ASSIST THE RESIDENT ENGINEER FOR ALL ROADWAY RESURFACING OR S.M.A.R.T. PROJECTS WHERE THE DIMENSIONS ARE NOT SHOWN ON THE PLANS AND THE FINAL LOCATIONS FOR CROSSWALKS OR STOP BARS ARE NOT DETERMINED.

Drawing file: W:\Projects\74009075 - Thatcher Ave\MARKINGS.dwg Jun 02, 2009 - 10:37am

FILE NAME = W:\data\22c34\1a07.dgn	USER NAME = geglambt	DESIGNED -	REVISED -	<b>STATE OF ILLINOIS DEPARTMENT OF TRANSPORTATION</b>	<b>DISTRICT 1 - DETECTOR LOOP INSTALLATION DETAILS FOR ROADWAY RESURFACING</b>		F.A. RTE. = 2753	SECTION 09-00009-00-RS	COUNTY COOK	TOTAL SHEETS 15	SHEET NO. 15
PLOT SCALE = 58.0000 / IN.	CHECKED - R.K.F.	DATE -	REVISED -		SCALE: NONE	SHEET NO. 1 OF 1 SHEETS	STA. TO STA.	<b>TS-07</b>		CONTRACT NO. 63215	
PLOT DATE = 1/4/2008	DATE -	REVISED -	REVISED -				FED. ROAD DIST. NO. 1 [ILLINOIS] FED. AID PROJECT ARA-9003 (349)				
E.H.E. PROJECT NO. 740-09-07501											