

BRIDGE APPROACH SPAN DETAILS

S.B. STRUCTURE 057-0214

N.B. STRUCTURE 057-0215

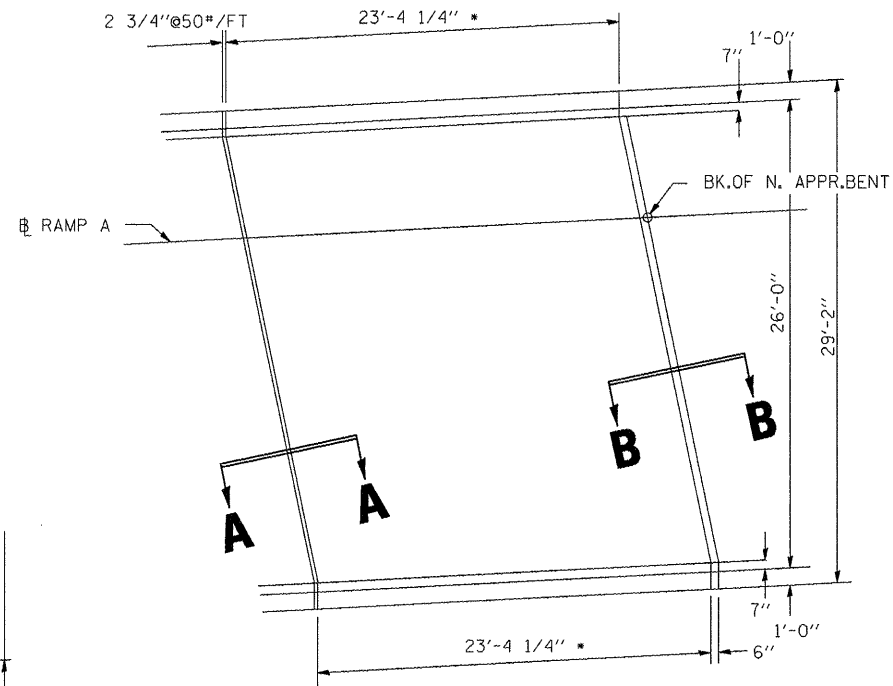

**NORTH APPROACH SPAN
STRUCTURE # 057-0214
(I-39 S.B. RAMP A)**

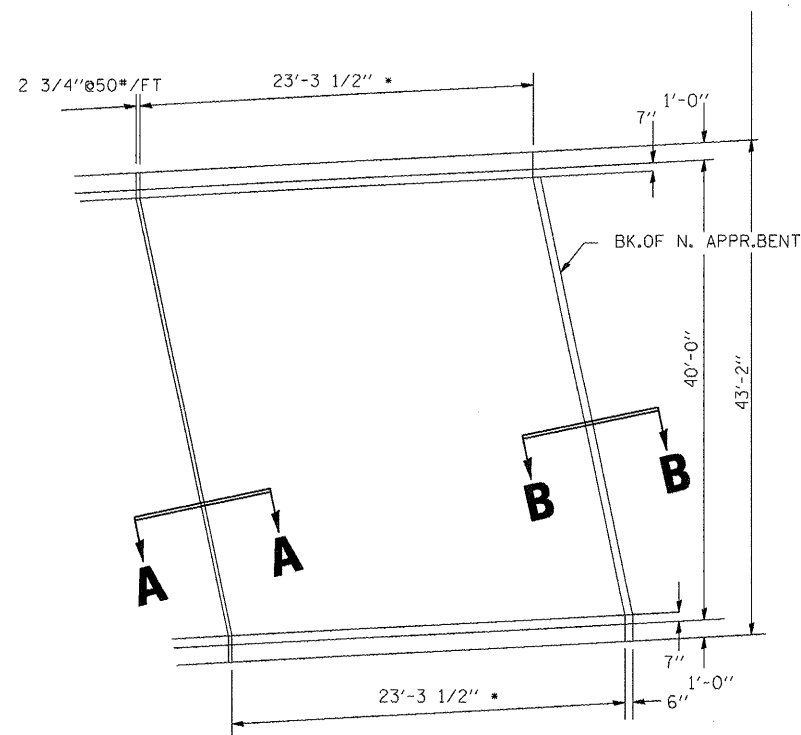

**NORTH APPROACH SPAN
STRUCTURE # 057-0215
(I-39 N.B. MAINLINE)**

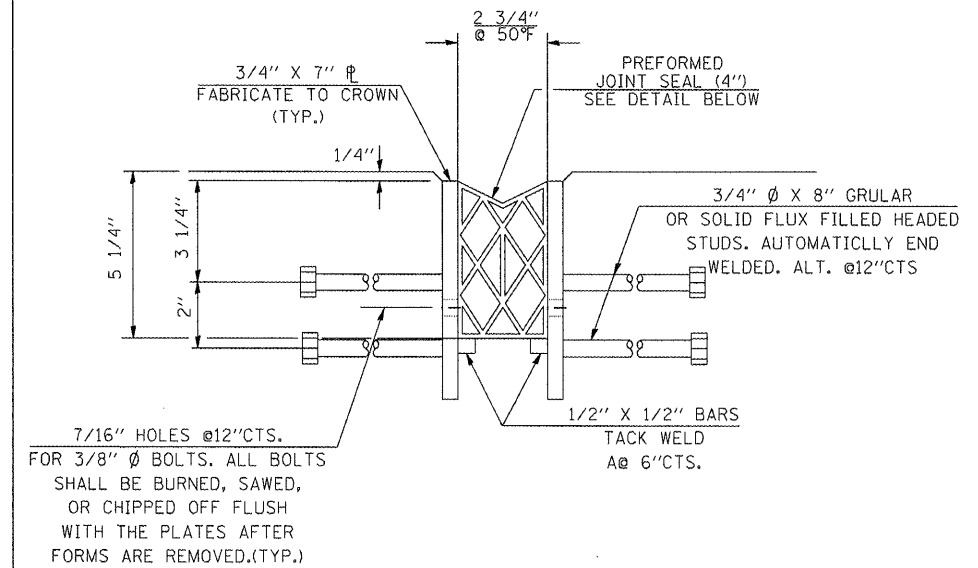

TYPICAL SECTION AT EXPANSION JOINT

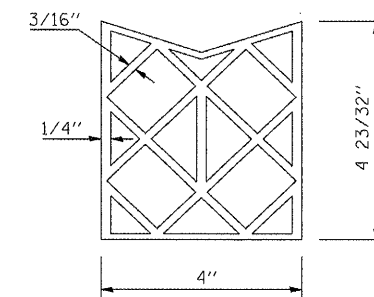

PREFORMED JOINT SEAL (4")

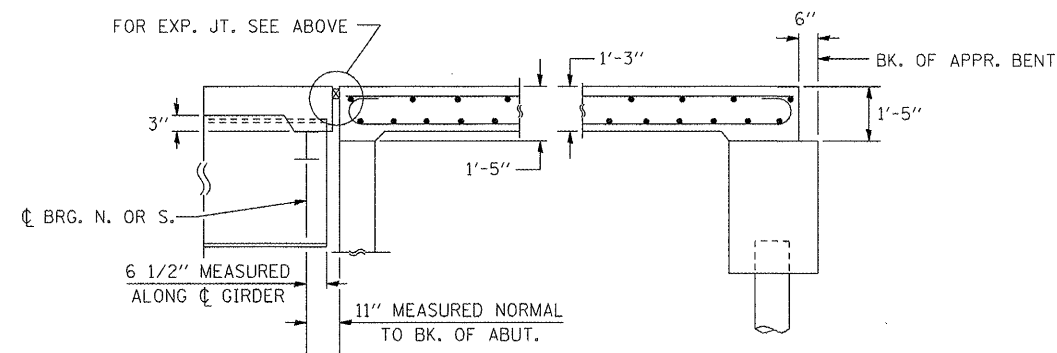

SECTION A-A

SECTION B-B

FILE NAME =	USER NAME = buckles.jj	DESIGNED -	REVISED -
ca:\pw\work\p\idat\buckles.jj\d0128799\0570215-SHT-PLAN.dgn		DRAWN - JJB	REVISED -
	PLOT SCALE = 48.0000' / IN.	CHECKED -	REVISED -
	PLOT DATE = 3/27/2009	DATE -	REVISED -

**STATE OF ILLINOIS
DEPARTMENT OF TRANSPORTATION**

DETAILS OF BRIDGE APPROACH SPAN AND ABUTMENTS			
SCALE:	SHEET NO.	OF SHEETS	STA. TO STA.

F.A.I. RTE. 39	SECTION 57-21	COUNTY MCLEAN	TOTAL SHEETS 18	SHEET NO. 11
CONTRACT NO. 70797				
[ILLINOIS] FED. AID PROJECT				