

PROJECT ENGINEER: REBECCA MARRUFFO

SQUAD LEADER: DAWN PERKINS (815)-284-5948

F.A.P. RTE.	SECTION	COUNTY	TOTAL SHEETS	SHEET NO.
742	37R-3	OGLE	345	1
FED. ROAD DIST. NO.		ILLINOIS	CONTRACT NO. 84788	

\*345+6=351

STATE OF ILLINOIS  
DEPARTMENT OF TRANSPORTATION

DIVISION OF HIGHWAYS

**PROPOSED  
HIGHWAY PLANS**

FAP ROUTE 742 (IL 2)  
SECTION 37R-3  
PROJECT ACF-0742(128)  
OGLE COUNTY

C-92-081-08



INDEX

SEE SHEET 2

STATE STANDARDS

SEE SHEET 2

IMPROVEMENT & SECTION ENDS  
STA. 752+50

OMISSION  
STA. 712+36 TO  
STA. 729+37

RECONSTRUCTION ENDS  
STA. 680+00

STATION EQUATION= STA. 620+11.65 BK=  
STA. 620+12.36 AH

IMPROVEMENT & SECTION BEGINS  
STA. 603+07.85

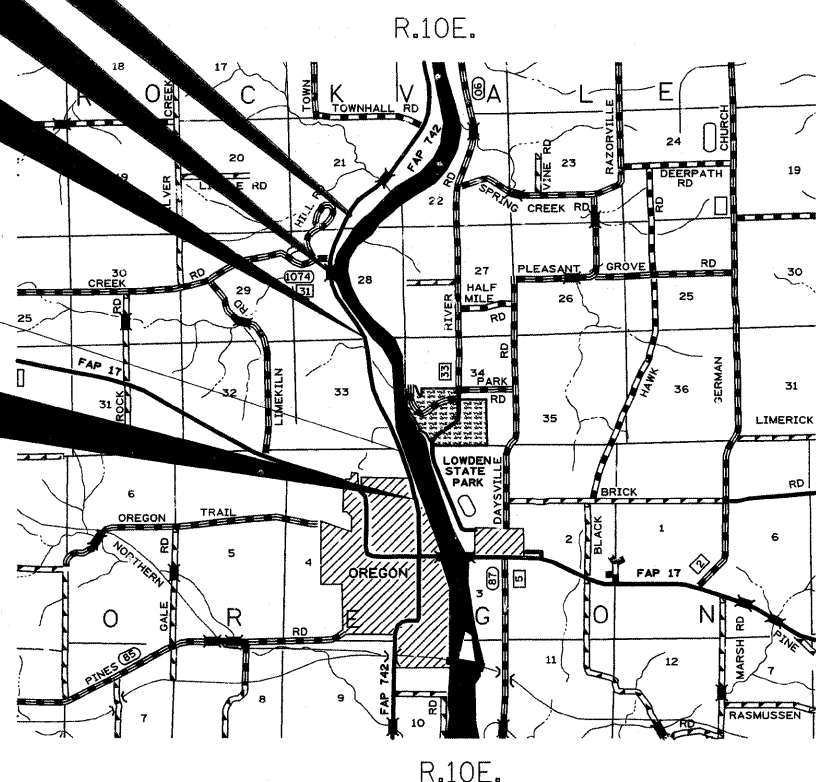

DESIGN DESIGNATION  
965 (15) OTHER PRINCIPAL ARTERIAL 5.51 (PCC-20)

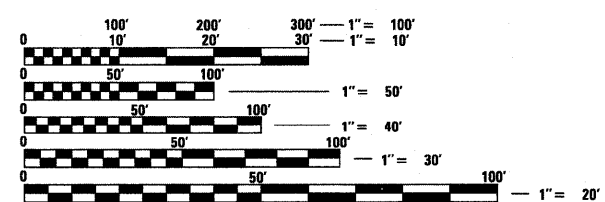

FULL SIZE PLANS HAVE BEEN PREPARED USING STANDARD  
ENGINEERING SCALES. REDUCED SIZED PLANS WILL NOT  
CONFORM TO STANDARD SCALES. IN MAKING MEASUREMENTS  
ON REDUCED PLANS, THE ABOVE SCALES MAY BE USED.

J.U.L.I.E.  
JOINT UTILITY LOCATION INFORMATION FOR EXCAVATION  
1-800-892-0123  
OR 811

CONTRACT NO. 84788

ROCKVALE TOWNSHIP, SECTION 28,33,21  
OREGON TOWNSHIP, SECTION 3,4  
GROSS LENGTH OF PROJECT = 14,942 LIN. FT. = 2.83 MILES  
NET LENGTH OF PROJECT = 13,241 LIN. FT. = 2.51 MILES



STATE OF ILLINOIS  
DEPARTMENT OF TRANSPORTATION  
DIVISION OF HIGHWAYS

SUBMITTED 511 20 09  
*Steve E. Brown*  
DEPUTY DIRECTOR OF HIGHWAYS, REGION ENGINEER

June 26, 2009  
*Charles G. Ingervold*  
ENGINEER OF DESIGN AND ENVIRONMENT

June 26, 2009  
*Christine M. Reed*  
DIRECTOR OF HIGHWAYS, CHIEF ENGINEER

**PRINTED BY THE AUTHORITY  
OF THE STATE OF ILLINOIS**

# INDEX OF SHEETS /STATE STANDARDS

## INDEX

1	COVER SHEET
2	INDEX OF SHEETS AND STANDARDS
3 - 8	SUMMARY OF QUANTITIES
9 - 12	GENERAL NOTES
13 - 29	TYPICAL SECTIONS / STAGING CULVERT TYPICALS
30 - 38	SCHEDULE OF QUANTITIES
39	EARTHWORK / SEEDING SCHEDULE
40 - 41	PAVING SCHEDULE
42	SUB-BASE SCHEDULE
43	ENTRANCE SCHEDULE
44	DRAINAGE SCHEDULE
45 - 48	PAVEMENT MARKING SCHEDULE
49	RAISED REFLECTOR SCHEDULE
50 - 51	TREE REMOVAL SCHEDULE
52 - 56	HORIZONTAL AND VERTICAL CONTROL
57 - 66	PLAN AND PROFILE
66A - 113	STAGING PLANS
114 - 126	EROSION CONTROL SHEETS
127 - 132	DRAINAGE DETAILS
133 - 147	PAVEMENT MARKING SHEETS / R.O.W. & EASEMENT SHEETS
148 - 152	PAVEMENT ELEVATION SHEETS
153 - 160	PAVEMENT JOINT SHEETS
161 - 181	RETAINING WALL DETAILS
182 - 195	CULVERT DETAILS
196 - 203	DROP BOX DETAILS
204 - 221	BORING LOGS
222	STANDARD INLET FOR CURB & GUTTER TYPE M-6.24
	DETAIL OF SHOULDER AT GUARDRAIL
	DRAIN FOR AGGREGATE BASE COURSE
222A	→ ENTRANCES AND SIDEROADS WITH 8' PCC SHOULDERS
223	SUPERELEVATION TRANSITION
224	TEMPORARY SUPPORT SYSTEM OPTION
225	GUTTER OUTLET ADJACENT TO STABILIZED SHOULDERS (15.4)
	GRADING AROUND WINGWALLS (20.4)
	CONCRETE HEADWALLS FOR PIPE DRAINS (27.4)
	CONCRETE GUTTER, TYPE A (MODIFIED) (36.4)
226	DELINEATOR AND POST ORIENTATION (37.4)
	TYPICAL BENCHING DETAIL ON EXISTING EMBANKMENT (50.4)
	LAND SECTION & CONCRETE REFERENCE MARKERS (63.4)
	INLET SPECIAL NO. 3 (79.4)
227	INLET SPECIAL NO.4 (79.4A)
	NOSE TYPE FOR INLET TOP SLAB (79.4D)
	INLET SPECIAL NO. 3, 4, 5, 6 REINFORCEMENT DETAIL (79.4E)
	DRAIN FOR AGGREGATE BASES IN URBAN AREAS (88.4)
228	LETTERING FOR NAME PLATE (89.4)
	TREE REPLACEMENT SCHEDULE (90.4)
	TYPICAL MARKING FOR PAINTED ISLAND (93.4)
	STOP LINE SIGN FOR TEMPORARY SIGNALS (99.4)
229	INLET SPECIAL (TYPE A GUTTER) (11.2)
	EROSION CONTROL DETAILS FOR SILT FENCE (29.2)
230	INFORMATIONAL WARNING SIGN (FOR NARROW TRAVEL LANES) (39.2)
	WITNESS MARKER & PERMANENT SURVEY MARKERS, TYPE II (66.2)
231	ENTRANCE SIGN FOR USE WITH TEMPORARY SIGNALS (75.2)
	THREE CENTER CURVE & TWO CENTER CURVE DATA (92.2)
232	TYPICAL AGGREGATE BASE SIDEROAD (93.2)
233	STORM WATER POLLUTION PREVENTION PLAN / EROSION CONTROL PLAN (2.1)
234	ENTRANCE APPROACHES - URBAN AREA (25.1)
235	CORRUGATED STEEL PIPE MULTIPLE END SECTIONS (34.1)
236	TRAFFIC CONTROL FOR ROAD CLOSURE (40.1)
237 - 239	TYPICAL PAVEMENT MARKINGS (41.1)
240	DETAILS OF PLANTING AND BRACING TREES (92.1)
241 - 345	CROSS SECTIONS

## STATE STANDARDS

280001-04	TEMPORARY EROSION CONTROL SYSTEMS
420001-07	PAVEMENT JOINTS
420101-04	24' (7.2m) JOINTED PCC PAVEMENT
420106-04	36' (10.8 m) JOINTED PCC PAVEMENT
420111-02	PCC PAVEMENT ROUNDOUTS
483001-04	PCC SHOULDER
515001-03	NAME PLATE FOR BRIDGES
542301-02	PRECAST REINFORCED CONCRETE FLARED END SECTION
542306-02	PRECAST REINFORCED CONCRETE ELLIPTICAL FLARED END SECTION
542401-01	METAL END SECTION FOR PIPE CULVERTS
542406-01	METAL END SECTION FOR PIPE ARCHES
601001-03	SUB-SURFACE DRAINS
601101-01	CONCRETE HEADWALL FOR PIPE DRAIN
604001-03	FRAME AND LIDS, TYPE 1
604041-02	FRAME AND GRATE, TYPE 9
606001-04	CONCRETE CURB TYPE B AND COMBINATION CURB AND GUTTER
606006-02	OUTLET FOR CONCRETE CURB AND GUTTER, TYPE B-6.24
606201-02	TYPE B GUTTER (INLET, OUTLET, & ENTRANCE)
630001-08	STEEL PLATE BEAM GUARDRAIL
630101-08	GUARDRAIL MOUNTED ON EXISTING CULVERTS
630301-05	SHOULDER WIDENING FOR TYPE 1 (SPECIAL) GUARDRAIL TERMINALS
631011-05	TRAFFIC BARRIER TERMINAL, TYPE 2
635001-01	DELINEATORS
635006-03	REFLECTOR AND TERMINAL MARKER PLACEMENT
635011-02	REFLECTOR MARKER AND MOUNTING DETAILS
642001-01	SHOULDER RUMBLE STRIPS
666001-01	RIGHT-OF-WAY MARKERS
701006-03	OFF-ROAD OPERATIONS, 2L, 2W, 4.5 M ( 15' ) TO 600 MM ( 24" ) FROM PAVEMENT EDGE
701011-02	OFF-ROAD MOVING OPERATIONS, 2L, 2W, DAY ONLY
701201-03	LANE CLOSURE, 2L, 2W, DAY ONLY, FOR SPEEDS >= 45 MPH
701301-03	LANE CLOSURE, 2L, 2W, SHORT TIME OPERATIONS
701306-02	LANE CLOSURE, 2L, 2W, SLOW MOVING OPERATIONS DAY ONLY, FOR SPEEDS >= 45 MPH
701311-03	LANE CLOSURE, 2L, 2W, MOVING OPERATIONS - DAY ONLY
701316-04	LANE CLOSURE, 2L, 2W, BRIDGE REPAIR, FOR SPEEDS >= 45 MPH
701321-10	LANE CLOSURE, 2L, 2W, BRIDGE REPAIR WITH BARRIER
701326-03	LANE CLOSURE, 2L, 2W, PAVEMENT WIDENING, FOR SPEEDS >= 45 MPH
701331-03	LANE CLOSURE, 2L, 2W, WITH RUN-AROUND, FOR SPEEDS >= 45 MPH
701501-05	URBAN LANE CLOSURE, 2L, 2W, UNDIVIDED
701701-06	URBAN LANE CLOSURE, MULTILANE INTERSECTION
701901-01	TRAFFIC CONTROL DEVICES
704001-05	TEMPORARY CONCRETE BARRIER
720011-01	METAL POSTS FOR SIGNS, MARKERS AND DELINEATORS
728001-01	TELESCOPING STEEL SIGN SUPPORT
729001-01	APPLICATIONS OF TYPES A AND B METAL POSTS (FOR SIGNS & MARKERS)
780001-02	TYPICAL PAVEMENT MARKINGS
781001-03	TYPICAL APPLICATIONS RAISED REFLECTIVE PAVEMENT MARKERS
886001-01	DETECTOR LOOP INSTALLATIONS
886006-01	TYPICAL LAYOUT FOR DETECTION LOOPS
000001-05	STANDARD SYMBOLS, ABBREVIATIONS AND PATTERNS
001001-02	AREAS OF REINFORCEMENT BARS
001006	DECIMAL OF AN INCH AND OF A FOOT

# SUMMARY OF QUANTITIES

CODE NUMBER	ITEM	UNIT	TOTAL QUANTITY	ROADWAY J000 80% FED 20% STATE
20100110	TREE REMOVAL (6 TO 15 UNITS DIAMETER)	UNIT	2365	2365
20100210	TREE REMOVAL (OVER 15 UNITS DIAMETER)	UNIT	2139	2139
20101000	TEMPORARY FENCE	FOOT	517	517
20101100	TREE TRUNK PROTECTION	EACH	100	100
20200100	EARTH EXCAVATION	CU YD	34025	34025
20201200	REMOVAL AND DISPOSAL OF UNSUITABLE MATERIAL	CU YD	239	239
20400800	FURNISHED EXCAVATION	CU YD	3885	3885
20800150	TRENCH BACKFILL	CU YD	432	432
21101615	TOPSOIL FURNISH AND PLACE, 4"	SQ YD	36841	36841
* 25000100	SEEDING, CLASS 1	ACRE	0.25	0.25
* 25000210	SEEDING, CLASS 2A	ACRE	4.00	4.00
* 25000310	SEEDING, CLASS 4	ACRE	0.75	0.75
* 25000400	NITROGEN FERTILIZER NUTRIENT	POUND	595	595
* 25000500	PHOSPHORUS FERTILIZER NUTRIENT	POUND	595	595
* 25000600	POTASSIUM FERTILIZER NUTRIENT	POUND	595	595
;) 25000750	MOWING	ACRE	15.25	15.25
25000775	SELECTIVE MOWING STAKES	EACH	102	102
* 25100115	MULCH, METHOD 2	ACRE	4.75	4.75
* 25100630	EROSION CONTROL BLANKET	SQ YD	6486	6486
* 25100900	TURF REINFORCEMENT MAT	SQ YD	1705	1705
* 25200110	SODDING, SALT TOLERANT	SQ YD	14531	14531
* 25200200	SUPPLEMENTAL WATERING	UNIT	130.8	130.8
28000250	TEMPORARY EROSION CONTROL SEEDING	POUND	12518	12518
28000300	TEMPORARY DITCH CHECKS	EACH	88	88
28000400	PERIMETER EROSION BARRIER	FOOT	10588	10588
28000500	INLET AND PIPE PROTECTION	EACH	55	55
28100107	STONE RIPRAP, CLASS A4	SQ YD	380	380
28100111	STONE RIPRAP, CLASS A6	SQ YD	813	813
28200200	FILTER FABRIC	SQ YD	1194	1194
28500400	ARTICULATED BLOCK REVETMENT MAT	SQ YD	198	198
31100910	SUB-BASE GRANULAR MATERIAL, TYPE A 12"	SQ YD	47729	47729
31100920	SUB-BASE GRANULAR MATERIAL, TYPE A 15"	SQ YD	450	450
31100935	SUB-BASE GRANULAR MATERIAL, TYPE A 18"	SQ YD	2474	2474

\* SPECIALITY ITEM

;) NON-PARTICIPATING (100% same)

FILE NAME =	USER NAME = cushmanbw	DESIGNED -	REVISED -
or\pwork\PWIDOT\CUSHMANBW\dms34123\03486cvt.dgn		DRAWN -	REVISED -
	PLOT SCALE = 50.0000' / IN.	CHECKED -	REVISED -
	PLOT DATE = Fri May 01 12:05:13 2009	DATE -	REVISED -

**STATE OF ILLINOIS  
DEPARTMENT OF TRANSPORTATION**

## SUMMARY OF QUANTITIES

SCALE: SHEET NO. OF SHEETS STA. TO STA.

F.A.P. RTE.	SECTION	COUNTY	TOTAL SHEETS	SHEET NO.
742	37R-3	OGLE	345	3
CONTRACT NO. 84788				
FED. ROAD DIST. NO. ILLINOIS FED. AID PROJECT				

# SUMMARY OF QUANTITIES

80% FED. 20% STATE  
TOTAL  
1000

ITEM NO.	DESCRIPTION	UNIT	TOTAL	1000
31100965	SUB-BASE GRANULAR MATERIAL, TYPE A 24"	SQ YD	611	611
35101400	AGGREGATE BASE COURSE, TYPE B	TON	6943	6943
40600200	BITUMINOUS MATERIALS (PRIME COAT)	TON	34.5	34.5
40600300	AGGREGATE (PRIME COAT)	TON	29	29
40600982	HOT-MIX ASPHALT SURFACE REMOVAL - BUTT JOINT	SQ YD	342	342
40600990	TEMPORARY RAMP	SQ YD	347	347
40702700	FURNISH PROFILOGRAPH	L SUM	1	1
40800050	INCIDENTAL HOT-MIX ASPHALT SURFACING	TON	3,384	3,384
42000411	PORTLAND CEMENT CONCRETE PAVEMENT 9 1/2" (JOINTED)	SQ YD	37576	37576
42001300	PROTECTIVE COAT	SQ YD	6037	6037
42300300	PORTLAND CEMENT CONCRETE DRIVEWAY PAVEMENT, 7 INCH	SQ YD	196	196
44000100	PAVEMENT REMOVAL	SQ YD	23602	23602
44000200	DRIVEWAY PAVEMENT REMOVAL	SQ YD	132	132
44000300	CURB REMOVAL	FOOT	67	67
44000400	GUTTER REMOVAL	FOOT	831	831
44000500	COMBINATION CURB AND GUTTER REMOVAL	FOOT	122	122
44201759	CLASS D PATCHES, TYPE IV, 9 INCH	SQ YD	426	426
48102100	AGGREGATE WEDGE SHOULDER, TYPE B	TON	305	305
48300410	PORTLAND CEMENT CONCRETE SHOULDERS 9 1/2"	SQ YD	12898	12898
48301000	PROTECTIVE COAT	SQ YD	905	905
50100300	REMOVAL OF EXISTING STRUCTURES NO. 1	EACH	1	1
50100400	REMOVAL OF EXISTING STRUCTURES NO. 2	EACH	1	1
50100500	REMOVAL OF EXISTING STRUCTURES NO. 3	EACH	1	1
50100600	REMOVAL OF EXISTING STRUCTURES NO. 4	EACH	1	1
50100700	REMOVAL OF EXISTING STRUCTURES NO. 5	EACH	1	1
50100800	REMOVAL OF EXISTING STRUCTURES NO. 6	EACH	1	1
50100900	REMOVAL OF EXISTING STRUCTURES NO. 7	EACH	1	1
50101000	REMOVAL OF EXISTING STRUCTURES NO. 8	EACH	1	1
50200100	STRUCTURE EXCAVATION	CU YD	327	327
50300225	CONCRETE STRUCTURES	CU YD	43.2	43.2
50800105	REINFORCEMENT BARS	POUND	40480	40480
50800515	BAR SPLICERS	EACH	85	85
51202210	FURNISHING SOLDIER PILES (HP SECTION)	FOOT	1629	1629
51202230	FURNISHING SOLDIER PILES (W SECTION)	FOOT	1377	1377
51205200	TEMPORARY SHEET PILING	SQ FT	2168	2168
51500100	NAME PLATES	EACH	7	7

\* SPECIALITY ITEM      : ) NON-PARTICIPATING

FILE NAME =	USER NAME = cushmanbw	DESIGNED -	REVISED -
at:\pw\work\PWIDOT\CUSHMANBW\dms34123\d	6486crr.dgn	DRAWN -	REVISED -
	PLOT SCALE = 50.0000' / IN.	CHECKED -	REVISED -
	PLOT DATE = Fri May 01 12:05:24 2009	DATE -	REVISED -

**STATE OF ILLINOIS  
DEPARTMENT OF TRANSPORTATION**

## SUMMARY OF QUANTITIES

SCALE:      SHEET NO.      OF      SHEETS      STA.      TO STA.

F.A.P. RTE.	SECTION	COUNTY	TOTAL SHEETS	SHEET NO.
742	37R-3	OGLE	345	4
CONTRACT NO. 84788				
FED. ROAD DIST. NO.    ILLINOIS FED. AID PROJECT				

# SUMMARY OF QUANTITIES

		TOTAL	80% FED. 20% STATE 3000
54001001	BOX CULVERT END SECTION, CULVERT NO. 1	EACH	1
54003000	CONCRETE BOX CULVERTS	CU YD	154.2
54010603	PRECAST CONCRETE BOX CULVERT 6' X 3'	FOOT	108
54010704	PRECAST CONCRETE BOX CULVERT 7' X 4'	FOOT	79
542A0235	PIPE CULVERTS, CLASS A, TYPE 1 30"	FOOT	78
542A8209	PIPE CULVERTS, CLASS A, TYPE 2 EQUIVALENT ROUND-SIZE 24"	FOOT	148
542D0220	PIPE CULVERTS, CLASS D, TYPE 1 15"	FOOT	628
54205905	PIPE CULVERTS, TYPE 1, CORRUGATED STEEL, EQUIVALENT ROUND-SIZE 30"	FOOT	507
54213450	END SECTIONS 15"	EACH	18
54213675	PRECAST REINFORCED CONCRETE FLARED END SECTIONS 30"	EACH	1
54214719	PRECAST REINFORCED CONCRETE FLARED END SECTIONS - ELLIPTICAL, EQUIVALENT ROUND-SIZE 24"	EACH	2
54215775	METAL END SECTIONS, EQUIVALENT ROUND-SIZE 30"	EACH	2
5422D036	PIPE CULVERTS, CLASS D, TYPE 2 36" (TEMPORARY)	FOOT	28
550A0070	STORM SEWERS, CLASS A, TYPE 1 15"	FOOT	621
550A0090	STORM SEWERS, CLASS A, TYPE 1 18"	FOOT	474
550A0120	STORM SEWERS, CLASS A, TYPE 1 24"	FOOT	128
550A0340	STORM SEWERS, CLASS A, TYPE 2 12"	FOOT	321
550A0360	STORM SEWERS, CLASS A, TYPE 2 15"	FOOT	653
59100100	GEOCOMPOSITE WALL DRAIN	SQ YD	374
60100060	CONCRETE HEADWALL FOR PIPE DRAINS	EACH	38
60107600	PIPE UNDERDRAINS 4"	FOOT	10177
60108100	PIPE UNDERDRAINS 4" (SPECIAL)	FOOT	753
60109580	PIPE UNDERDRAINS FOR STRUCTURES 4"	FOOT	458
60242700	INLETS, SPECIAL, NO. 3	EACH	8
60242800	INLETS, SPECIAL, NO.4	EACH	7
60244110	INLETS, SPECIAL, WITH TYPE 9 FRAME AND GRATE	EACH	2
60255500	MANHOLES TO BE ADJUSTED	EACH	2
60406100	FRAMES AND LIDS, TYPE 1, CLOSED LID	EACH	1
60500040	REMOVING MANHOLES	EACH	2
60500060	REMOVING INLETS	EACH	2
60600095	CLASS SI CONCRETE (OUTLET)	CU YD	8.8
60602600	CONCRETE GUTTER, TYPE A (MODIFIED)	FOOT	433.5
60605000	COMBINATION CONCRETE CURB AND GUTTER, TYPE B-6,24	FOOT	1064
60610400	COMBINATION CONCRETE CURB AND GUTTER, TYPE M-6,24	FOOT	1467

\* SPECIALITY ITEM

□) NON-PARTICIPATING



# SUMMARY OF QUANTITIES

80% FED. 20% STATE

			TOTAL	1000	
*	78008200	POLYUREA PAVEMENT MARKING TYPE I - LETTERS AND SYMBOLS	SQ FT	1080	1080
*	78008210	POLYUREA PAVEMENT MARKING TYPE I - LINE 4"	FOOT	18081	18081
*	78008240	POLYUREA PAVEMENT MARKING TYPE I - LINE 8"	FOOT	1218	1218
*	78008250	POLYUREA PAVEMENT MARKING TYPE I - LINE 12"	FOOT	2069	2069
*	78008270	POLYUREA PAVEMENT MARKING TYPE I - LINE 24"	FOOT	158	158
*	78100100	RAISED REFLECTIVE PAVEMENT MARKER	EACH	602	602
	78200410	GUARDRAIL MARKERS, TYPE A	EACH	34	34
	78201000	TERMINAL MARKER - DIRECT APPLIED	EACH	5	5
*	78300100	PAVEMENT MARKING REMOVAL	SQ FT	5743	5743
	Z0005400	BREAKER-RUN CRUSHED STONE	TON	1506	1506
	Z0013798	CONSTRUCTION LAYOUT	L SUM	1	1
	Z0025500	FURNISHING AND INSTALLING PROPERTY MARKERS	EACH	60	60
	Z0030250	IMPACT ATTENUATORS, TEMPORARY (NON-REDIRECTIVE), TEST LEVEL 3	EACH	5	5
	Z0030350	IMPACT ATTENUATORS, RELOCATE (NON-REDIRECTIVE), TEST LEVEL 3	EACH	9	9
	Z0073400	TEMPORARY SUPPORT SYSTEM	EACH	2	2
⊙	Z0076600	TRAINEES	HOUR	1,500	1,500
*	A2C022G3	TREE, CARYA ILLINOINENSIS (PECAN), CONTAINER GROWN, 3-GALLON	EACH	50	50
*	A2C040G3	TREE, PLATANUS OCCIDENTALIS (SYCAMORE), CONTAINER GROWN, 3-GALLON	EACH	50	50
*	A2C050G3	TREE, QUERCUS BICOLOR (SWAMP WHITE OAK), CONTAINER GROWN, 3-GALLON	EACH	50	50
*	A2C060G3	TREE, QUERCUS PALUSTRIS (PIN OAK), CONTAINER GROWN, 3-GALLON	EACH	75	75
*	A2001714	TREE, ACER SACCHARUM (SUGAR MAPLE), 1-3/4" CALIPER, BALLED AND BURLAPPED	EACH	26	26
*	A2001724	TREE, ACER SACCHARUM (SUGAR MAPLE), 3" CALIPER, BALLED AND BURLAPPED	EACH	8	8
*	A2006720	TREE, QUERCUS MACROCARPA (BUR OAK), 2-1/2" CALIPER, BALLED AND BURLAPPED	EACH	3	3
*	A2007114	TREE, QUERCUS RUBRA (RED OAK), 1-3/4" CALIPER, BALLED AND BURLAPPED	EACH	25	25
*	B2001116	TREE, CERCIS CANADENSIS (EASTERN REDBUD), 2" CALIPER, <sup>TREE FORM,</sup> BALLED AND BURLAPPED	EACH	3	3
*	B2004114	TREE, MALUS PRAIRIFIRE (PRAIRIFIRE CRABAPPLE), 1-3/4" CALIPER, <sup>TREE FORM,</sup> BALLED AND BURLAPPED	EACH	3	3
*	D2002272	EVERGREEN, PICEA PUNGENS GLAUCA (COLORADO BLUE SPRUCE), 6' HEIGHT, BALLED AND BURLAPPED	EACH	4	4
*	D2003872	EVERGREEN, THUJA OCCIDENTALIS TECHN (TECHNY ARBORVITAE), 6' HEIGHT, BALLED AND BURLAPPED	EACH	50	50
	X0321461	PILLAR REMOVAL	EACH	4	4
*	X0322352	SEEDING MOBILIZATION	EACH	3	3
	X0323660	DROP BOX NO. 1	EACH	1	1
	X0323661	DROP BOX NO. 2	EACH	1	1
	X0323662	DROP BOX NO. 3	EACH	1	1
	X0323663	DROP BOX NO. 4	EACH	1	1
	X0323664	DROP BOX NO. 5	EACH	1	1

\* SPECIALITY ITEM      ⊙ ) NON-PARTICIPATING      ⊙ Y080

FILE NAME = c:\pwwork\pwwid\DOT\CUSHMANBW\dms34123\06486c\vr.dgn	USER NAME = cushmanbw	DESIGNED - DRAWN -	REVISED - REVISED -	STATE OF ILLINOIS DEPARTMENT OF TRANSPORTATION	<b>SUMMARY OF QUANTITIES</b>	F.A.P. RTE. 742	SECTION 37R-3	COUNTY OGLE	TOTAL SHEETS 345	SHEET NO. 7	
PLOT SCALE = 50.0000' / IN.	CHECKED -	REVISED -	SCALE:			SHEET NO. OF SHEETS	STA. TO STA.	CONTRACT NO. 84788			
PLOT DATE = Fri May 01 12:05:58 2009	DATE -	REVISED -	FED. ROAD DIST. NO. ILLINOIS FED. AID PROJECT								

# SUMMARY OF QUANTITIES

80% FED 20% STATE

		TOTAL		1000	
*	X0324455	DRILLING AND SETTING SOLDIER PILES (IN SOIL)	CU FT	7000	7000
	X0324548	PRECAST CONCRETE BOX CULVERT END SECTIONS 6' X 3'	EACH	2	2
	X0325519	DRAIN FOR AGGREGATE BASE COURSE	SQ YD	9	9
	X0325666	CORRUGATED STEEL PIPE MULTIPLE END SECTIONS EQUIVALENT DOUBLE ROUND-SIZE 30"	EACH	4	4
	X0325751	DRIVING SOLDIER PILES	F00T	1222	1222
	X0325919	PRECAST CONCRETE BOX CULVERT 7' X 3' (SPECIAL)	F00T	125	125
	X0712400	TEMPORARY PAVEMENT	SQ YD	6638	6638
	X0919000	TEMPORARY PAVEMENT REMOVAL	SQ YD	6121	6121
	X7013015	TRAFFIC CONTROL FOR ROAD CLOSURE	L SUM	1	1
*	X7800610	URETHANE PAVEMENT MARKING-LINE 4"	F00T	20246	20246
*	X7800640	URETHANE PAVEMENT MARKING-LINE 8"	F00T	3437	3437
	XX002030	FLAGSTONE WALL REMOVAL	F00T	23	23
	XX006040	STONE PILLARS TO BE RELOCATED	EACH	2	2
	XX006807	TIMBER RETAINING WALL MODIFICATION	F00T	13	13
	XX007023	STAINING CONCRETE STRUCTURES	SQ YD	181	181
	XX006084	REMOVE EXISTING MONUMENT	EACH	1	1
	XX001607	RETAINING WALL, SPECIAL	SQ FT	4285	4285
	X5400602	PRECAST CONCRETE BOX CULVERT 6' X 2' (SPECIAL)	F00T	77	77



# GENERAL NOTES

ROUTE NO.	SEC.	COUNTY	TOTAL SHEETS	SHEET NO.
FAP 742	37R-3	Ogle	345	9
FED ROAD DIST. NO.	ILLINOIS	PROJECT		
Contract #84788				

See cross sections for special ditches and backslopes.

The removal of Bituminous Surfacing not on a rigid type base removed in conjunction with the base shall be removed as EARTH EXCAVATION. The removal of Bituminous Surfacing on a rigid type base removed in conjunction with the base shall be included in the contract unit price for PAVEMENT REMOVAL of the type specified.

The final top 100 mm (four inches) of soil in any right-of-way area disturbed by the Contractor must be capable of supporting vegetation. The soil must be from the A horizon (zero to 2' deep) of soil profiles of local soils.

It is estimated that 3665 cubic yards of earth will be hauled to the job from outside the project limits. A shrinkage factor of 25% has been used.

All Borrow/Waste/Use sites must be approved by the Department prior to removing any material from the project or initiating any earthmoving activities, including temporary stockpiling outside the limits of construction.

The Contractor shall seed or sod all disturbed areas within the project limits. Seeding Class 4 or 2A shall be used, except in front of properties where the grass will be mowed, then use Seeding Class 1 or Sodding as shown on the Erosion Control Sheets. Class 2A shall be used on front slopes and ditch bottoms. Class 4 shall be used behind Type A gutter, on all backslopes and areas behind the backslope, and beyond the toe of front slope on fill sections without ditches.

Previously pugmilled stockpiles of "Type A" older than 1 month will not be approved for use until a moisture check is run to verify moisture content. Material shipped to projects without being tested will not be accepted.

Placement and compaction of the backfill for proposed across road culverts and existing across road culverts that are removed shall conform to Section 502.10 of the Standard Specifications, except that the material shall conform to Article 208.02 of the Standard Specifications, and shall be compacted to a minimum of 95% of the standard laboratory density. Any material conforming to the requirements of Article 1003.04 or 1004.05 which has been excavated from the trenches shall be used for backfilling the trenches. The entire excavation, within 2 feet outside of each shoulder, shall be backfilled with trench backfill material to the bottom of the proposed subgrade. This trench backfill material will not be measured for payment, but shall be included in the contract unit price for the class of concrete involved or other unit price item of the work for which it is required.

The subgrade on this project, exclusive of rock cut areas is scheduled to be improved to a 300 mm (12") depth according to Mechanistic Pavement Design. The areas scheduled to be improved to a depth greater than 300 mm (12") are estimated based on the original geotechnical investigation. The subgrade shall be processed in accordance with Article 301.03 of the Standard Specifications before the engineer shall determine the limits and the additional thickness of improvement required, if any. Any additional undercutting required after this evaluation shall be paid for as EARTH EXCAVATION.

Except for the top 75 mm (3"), all aggregate bases and subbases 300 mm (12") in thickness shall be constructed of aggregate gradation CA-2. If the specified thickness exceeds 300 mm (12"), the bases or subbases shall be constructed of topsize 150 mm (6") breaker-run crushed stone with 70% to 90% by weight, passing the 4" sieve and 15% to 40% by weight, passing the 50 mm (2") size sieve, except for the top 75 mm (3"). The breaker-run crushed stone shall be reasonably uniformly graded from coarse to fine and be taken from a quarry ledge capable of producing Class "D" quality aggregate. The top 75 mm (3") shall be gradation CA-6 or CA-10 regardless of thickness. The water necessary to achieve compaction in all but the top 75 mm (3") layer may be added after the subbase or base course is placed on the grade.

All embankment constructed of cohesive soil shall be constructed with not more than 110% of optimum moisture content, determined by the standard proctor test. Cohesive soil shall be defined as any soil which contains greater than 10% particles by weight passing the 75 µm (#200 sieve). The 110% of optimum moisture limit may be waived in free-draining granular material when approved by the Engineer.

Cost of removal and disposal of material from the temporary patch shall be included in AGGREGATE BASE COURSE, TYPE B.

The existing hot-mix asphalt on private and commercial entrances shall be bladed off or milled and disposed of outside the project limits. This could be the entire entrance or tapered at the end depending on if the mainline is resurfaced or milled and resurfaced. The cost of the blading, milling, rolling, and disposal is included in the contract unit price for INCIDENTAL HOT-MIX ASPHALT SURFACING.

The following Mixture Requirements are applicable for this project:

Mixture Uses(s):	Incidental	Temporary Pavement
PG:	PG 64-22	PG 64-22
Design Air Voids	4.0 @ N50	4.0 @ N50
Mixture Composition (Gradation Mixture)	IL 9.5 or 12.5	IL 19.0
Friction Aggregate	C	N/A
20 Year ESAL	N/A	2.2

The Contractor will be required to furnish 140 mm (5 1/2") high brass stencils as approved by the Engineer and install stationing at 250' intervals. Stationing shall be placed on both lanes of 2-lane highways and on the outside lanes in both directions on 4-lane highways. The stations shall be placed 150 mm (6") inside the pavement marking edge so they can be read from the shoulder. This work will be included in the cost of the final pavement surface.

Install rumble strips in all shoulders in accordance with State Standard 642001. Rumble Strips shall be placed on shoulders on both sides of the pavement.

A Nationwide 404 Permit has been issued for this project and the conditions of that permit must be adhered to.

The new number for the structure located at Sta. 615+22 is 071-1132.

The new number for the structure located at Sta. 626+61 is 071-1131.

The new number for the structure located at Sta. 635+63 is 071-1133.

The new number for the structure located at Sta. 654+30 is 071-1202.

The new number for the structure located at Sta. 659+22 is 071-1126.

The new number for the structure located at Sta. 667+20 is 071-1203.

The new number for the structure located at Sta. 678+70 is 071-1127.

The contractor shall submit four copies of the required shop drawings for review and approval to the Bureau of Bridges and Structures, 2300 South Dirksen Parkway, Springfield, IL 62764. After approval of initial submittal, the contractor shall submit one set of shop drawings to Dave Lippert, Engineer of Materials, 126 East Ash Street, Springfield, IL 62706, and eight (8) sets of shop drawings to be distributed to:

District 2 District Engineer (1)  
 Fabricator (1)  
 Contractor (2)  
 Resident Engineer (2)  
 District 2 Bureau of Materials (2)

The review and approval of temporary sheet piling will require 4 to 6 weeks. The Contractor shall schedule his work accordingly.

The area to be primed shall be limited to that which can be covered with HMA the same day, unless otherwise permitted by the Engineer.

Program #5  
 (Arch. Size)  
 Enlarge  
 200%  
 Enlarge 107%

# GENERAL NOTES

ROUTE NO.	SEC.	COUNTY	TOTAL SHEETS	SHEET NO.
FAP 742	37R-3	Ogle	345	10
FED ROAD DIST. NO.	ILLINOIS	PROJECT		
Contract #84788				

The boring logs for this project indicate that groundwater levels may encroach on the construction limits of the culverts. It shall be the responsibility of the contractor to control the ground water and divert the stream flow during construction in order to keep the construction area free of water. The method of controlling the water shall be subject to approval of the Engineer and the cost shall be included in the contract unit price for Precast Concrete Box Culverts.

Culvert & bridge flows must be maintained throughout the project. Normal flow shall be allowed to pass at the rate it enters the jobsite. High flows shall be allowed to pass without causing damage to upstream properties.

Box culverts that are stage constructed and undercut by more than 600 mm (2 feet) shall have lean concrete placed on the rock fill at the stage line. The concrete shall retain the rock fill until the second stage rock fill is placed. This work will be included in the pay item for the type of rock fill used.

A Precast Box Culvert is not an option at Sta. 678+70 AR Culvert due to soil conditions.

The proposed pipes for entrances and side roads shall be placed in line with the existing or proposed ditch line.

Connecting bands for corrugated metal pipes shall be metal and shall be coated with the same material as the pipe sections. The connecting bands shall be a minimum of 18" wide.

It is anticipated that several mailboxes will require relocation to the approach side of the entrances. When this is done, the contractor shall be required to mount the mailbox on a 100 mm x 100 mm (4" x 4") wood post 1 m (40 inches) above the shoulder surface and extending to a minimum of 0.6 m (24 inches) into the embankment. This work shall be included in the contract unit price for the EARTH EXCAVATION. There are an estimated 20 mailboxes to be relocated (See Commitments).

All frames and grates of drainage structures to be removed or filled shall be carefully salvaged and shall remain the property of the City of Oregon.

The cost of making sewer connections to existing drainage structures shall be included in the various contract unit prices for STORM SEWER.

Valve Boxes shall be adjusted to the final grade as shown on the plans. The cost of adjusting Valve Boxes shall not be paid for separately but shall be included in the contract unit price for the various items of work.

The cost of removing existing Storm Sewer during the installation of new storm sewers shall be included in the contract unit price for the STORM SEWER being installed.

Lateral distances from the centerline on all inlets are to the face of the inlet.

The new manhole lids on this project shall have the word "STORM", "SANITARY", or "WATER" on the lid. The word to be used is noted on the plans. It will be the Contractor's responsibility to determine the word to be used on other lids not noted on the plans. No additional compensation will be allowed for this work.

The excavated materials from earth excavation widening, grading and shaping ditches, and excavating and grading shoulders shall be used to build up the shoulder throughout the job to conform with the typical sections and shoulder widening for terminals as shown on the plans.

Embankment quantities for the construction of the Traffic Barrier Terminals as shown in the plans are included in quantities for Earth Excavation.

The Contractor shall supply the Resident Engineer with the manufacturer's installation requirements for the type of Steel Plate Beam Guardrail Terminal Type 1 Special (Tangent).

One 16d galvanized nail shall be used to toe nail the wood block out to the wood post on all Traffic Barrier Terminal Type I Specials.

Delineators shall be installed as shown in Standard 635001, except that the post shall be rotated 180° and only metal-backed delineators shall be permitted.

Delineators shall be placed at the ends of approach guardrail terminal sections, and at each headwall or end section of AR Culverts. This work will be paid for at the contract unit price each for DELINEATORS.

Pavement Marking shall be done according to Standard 780001, except as follows:

1. All words, such as ONLY, shall be 2.4 m (8 feet) high.
2. All non-freeway arrows shall be the large size.
3. The distance between yellow no-passing lines shall be 200 mm (8"), not 180 mm (7") as shown in the detail of Typical Lane and Edge Lines.

PERMANENT SURVEY MARKERS, TYPE II, shall be set at intervals of 1.6 Km (1 mile) or as directed by the Engineer. Bridge or culvert projects shall have one survey marker placed near the structure. Estimated: 14 Each.

Permanent Survey Markers, Type II shall be cast-in-place as shown on District Standard 66.2. The bottom of the marker shall be 5'-0" below the ground surface.

The Contractor shall submit to the Engineer a description of location, elevation, and coordinates for each permanent survey marker. The horizontal and vertical coordinates must be derived by GPS and the elevation derived by a closed level circuit. The Engineer shall submit this information to the Survey Crew.

Tree planting layout shall be performed by the District Landscape Architect. Mulch shall be placed 4" thick and to the diameter around the tree as shown on District Standard 92.1. The mulch shall be hardwood wood chips placed on weed barrier fabric. This work shall be included in the cost of the tree.

Septic tanks within the right of way which have not been removed and will not interfere with construction shall be filled with free-flowing sand at the direction of the Engineer. Cost of this work shall be included in the contract unit price per EARTH EXCAVATION.

Aggregate Base Course, Type B, is provided in the plan quantities and shall be used only as needed when directed by the Engineer.

All gutter outlets shall be extended to ditch flow as directed by the Engineer.

Right-of-way markers will be erected with the back face of the marker on the right-of-way line unless the new right-of-way line has been surveyed and pinned, in which instance the right-of-way markers will be erected 300 mm (12 inches) inside the new right-of-way line.

Work on this project may be in progress at the same time as work on the IL 2 - 0.8 mile south of Mud Creek to Mill Creek west of Byron. Work on these projects shall be scheduled to keep interference between all the projects to a minimum. The contractors shall inform each other of progress of the projects and give fair warning to the other contractors when a problem might be encountered.

The Contractor shall be responsible for protecting utility property during construction operations as outlined in Article 107.31 of the Standard Specifications. A minimum of 48 hours advance notice is required for non-emergency work. The JULIE number is 800-892-0123. The following listed utilities located within the project limits or immediately adjacent to the project construction limits are members of JULIE:

Commonwealth Edison	Verizon
Nicor Gas Co.	Insight Communications
Alliance Pipeline Co.	City of Oregon

The applicable portions of Article 105.07 of the Standard Specification shall apply except for the following: The Contractor shall be responsible to locate the vertical depths of the underground utilities which may interfere with construction operations. This work will not be measured or paid for separately, but shall be considered as included in the unit bid price for the item of construction involved.

# GENERAL NOTES

ROUTE NO.	SEC.	COUNTY	TOTAL SHEETS	SHEET NO.
FAP 742	37R-3	Ogle	345	11
FED ROAD DIST. NO.	ILLINOIS	PROJECT		
Contract #84788				

Per SB 699 (90 day utility relocation law), once right-of-way is clear to award the project, a notice will be sent to the utility companies instructing them to have their facilities relocated within 90 days. Estimated date relocation complete = Letting Date + 135 days.

CADD data will be available to Contractors and Consultants working on this project. This information will be provided upon request as MicroStation CADD files and Geopak coordinate geometry files **ONLY**. If data is required in other formats it will be your responsibility to make these conversions. If any discrepancy or inconsistency arises between the electronic data and the information on the hard copy, the information on the hard copy should be used. Contact the District's Project Engineer to request these files.

It shall be the Contractor's responsibility to contact the municipality to determine approved methods of utility structure adjustment. Utility structures may include, but are not limited to, manholes, water valves, handholes, etc. All materials and work necessary to complete adjustments per municipality requirements shall be considered included in the cost of the associated adjustment pay item.

From Lt. Sta. 663+50 to Lt. Sta. 684+00, the Contractor shall cut off the trees and brush flush with the ground surface and leave the root system in place to prevent erosion. If earthwork and removal of roots and stumps are required for construction activities, no additional compensation shall be provided.

The underdrain system scheduled on this project is to be constructed in accordance with Section 601 of the Standard Specifications for Road and Bridge Construction, except when the Recurring Special Provision Pipe Underdrains is included, the fabric envelope encasement of the pipe shall be omitted.

The color and pattern for the Retaining Wall, Special shall be pre-approved by the Resident Engineer and Phase II Project Engineer.

The temporary concrete barrier shall be anchored to the pavement with 6 anchors per section at the following locations:

- Sta. 677+75 to 679+00 (Stage 2)
- Sta. 674+50 to 679+00 (Stage 3)
- Sta. 614+69.97 to 615+70.21 (Stage 6)
- Sta. 614+20.03 to 616+20.02 (Stage 7)

The Contractor shall not disturb the landings and/or stairs that access the Rock River from Rt. Sta. 604+00 to 635+00.

The Contractor shall be responsible for coordination with the City of Oregon and their Contractor(s) regarding installation of a sanitary sewer line from Fair Street to Access Road A and B intersections with IL 2.

## POLICY GUIDELINES

1. All trees removed from the project area (1,500 trees, max. plus 6.3 acres) for construction or maintenance purposes will be replaced with deciduous tree species which are native to the District 2 area. Trees will be replaced according to the IDOT Departmental Policy D&E-18 (September 18, 2002). The location of the replacement trees shall be determined by the District 2 Landscape Architect.
2. According to IDOT BDE Procedure Memorandum 99-34 and Operations Policy 5-1800, all unmowed areas should be designated in the plans and seeded with the appropriate native seeding selections from Class 4, per directive of the December 8, 1999 Studies and Plans Engineer's Memorandum.

## COMMITMENTS

1. There is one (1) regulatory wetland which will be impacted by this proposed project. These areas are listed below by stationing. No construction activities, including equipment and material storage, driving vehicles and equipment, shall take place beyond the construction limits shown on the contract plans in these areas so as to avoid further wetland impacts to the wetlands listed below:

Site #	Station
12	Station 666+00 to 668+50 Left

2. There is one (1) regulatory wetlands which will not be impacted by the proposed roadway project. No construction activities, including equipment and material storage, driving vehicles and equipment, shall take place beyond the construction limits shown on the contract plans in these areas so as to avoid any impacts to those wetland. These areas are listed below:

Site #	Station
14	Station 669+00 to 678+00 Right

3. The area located Right Station 669+00 to 678+00 is a proposed boat ramp and parking area to be built by others. Construction of this facility will potentially impact Wetland Sites #13 and 14. Therefore, any construction in this area beyond that shown for the entrance in the contract plans may impact wetlands which have not been mitigated by this project. This construction will potentially require additional mitigation and a 404 Permit.
4. The proposed IL 2 projects will impact a maximum total of 1.49 acres in eight different regulatory wetland sites. This will be mitigated by purchasing 2.283 acres of mitigation bank credits at the Kilbuck Creek Wetland Mitigation Bank, which is off-site, but in-basin.
5. There are four (4) areas along the proposed project which contain high quality natural plant communities. No construction activities, including equipment and material storage, driving vehicles and equipment, shall take place beyond the construction limits shown on the contract plans in these areas so as to avoid impacts or further impacts to these areas. These areas are listed below:

Site #	Station
1	Station 626+50 to 637+00 Right
2	Station 666+00 to 672+00 Left
3	Station 672+50 to 678+50 Left
4	Station 679+00 to 704+00 Left

6. Curb and gutter and/or retaining walls will be installed in the areas listed below to minimize impacts to the adjacent wetlands or high quality natural plant community:

Station
Station 666+00 to 672+00 Left (curb & gutter)
Station 672+50 to 678+50 Left (wall)
Station 679+00 to 704+00 Left (curb & gutter)

# GENERAL NOTES

ROUTE NO.	SEC.	COUNTY	TOTAL SHEETS	SHEET NO.
FAP 742	37R-3	Ogle	345	12
FED ROAD DIST. NO.	ILLINOIS	PROJECT		
Contract #84788				

7. One area along the proposed project will require the construction of retaining walls. This will decrease the amount of fill in the river, avoid impacts to the surrounding area, and make the river bank more aesthetically pleasing, as requested by IDNR. The locations of the retaining walls are as follows:

Station  
Station 633+50 to 637+00

8. Retaining walls throughout the project will have a rock face similar to those already along IL 2.
9. Only those trees shown to be removed on the contract plans shall be removed. All other trees shall be saved.
10. Any underground utilities shall be directionally bored to avoid further tree loss.
11. No trees shall be removed until after a field meeting with the Resident Engineer, the Landscape Architect, all affected utilities, and members of the Environment Unit.
12. Trees close to the construction limits shall be protected with Tree Trunk Protection per Standard Specification Section 201.10(c)(2). The contract shall contain 500 pay items (each). The exact location shall be determined during the field meeting per Commitment #11.
13. All trees agreed to be removed will be marked only with paint on their back side.
14. All trees cut down or trimmed will be removed by the Contractor from the view of the motorists on this highway within the same day as they are cut.
15. The Department will coordinate with Illinois Department of Natural Resources and the Oregon Park District regarding a possible public boat ramp north of Oregon.
16. The Department will coordinate with the Oregon Women's Club regarding the relocation of the World War I marker located on the west side of IL 2 adjacent to the Riverview Cemetery entrance (Sta. 618+00). This commitment has been revised by the Project Engineer. The Department will contact Curtis Cook, Ogle County Engineer, regarding ownership of the plaque.
17. The Department will coordinate with the City of Oregon regarding possible city sewer and water main work that will extend to the Stillman Bank/Maxson Manor area along IL 2.
18. The Department will reduce the amount of proposed right of way necessary from the intersection, Sta. 677+00, so there will be adequate room for the Stronghold sign on the property owned by the Presbytery of Blackhawk.
19. The Department will require flatter slopes (1:4 ratio) at the ditch for the culvert to ease mowing at the property previously owned by Hugh and Joyce McCleery on Cartwright Lane and currently owned by Emory and Virginia Cragg (Sta. 37+75 to Sta. 39+50). This commitment was made by the project engineer. The Department will remove three trees located on the Cragg property at Lt. Sta. 37+81, Lt. Sta. 37+87, and Lt. Sta. 38+06. A Temporary Use Permit was secured by the Land Acquisition Representative. This commitment was made by the Land Acquisition Representative.
20. The Department will save several trees located on the property owned by Connie Miller (Rt. Sta. 47+00). This commitment was made by the project engineer.
21. The Department will include rumble strips on the shoulders as suggested by Arlene Kocher, FHWA Field Engineer. This commitment was made by the project engineer.

22. A commitment was made to the IL Route 2 Citizens' Committee that they would be involved in the landscaping for this section of IL 2 as they had been on the first section from Dixon to Oregon. This commitment was made by the project engineer.
23. A commitment was made to the IL Route 2 Citizens' Committee that the committee would be contacted before Phase III so they would be aware of any changes that were made to the project. This commitment was made by the project engineer.
24. Tree removal for the project will be conducted between August 30<sup>th</sup> and April 1<sup>st</sup> to avoid impacting neo-tropical migratory birds during their nesting season.
25. Commitments were made stating that the Contractor will not park or store any equipment or material on your property except while working; the Contractor will not disturb the storage building nor the trees within the TE areas, unless marked as removal; the Contractor will place tree protection on the trees marked as save; the Department will limit the purchase of Proposed Right-of-Way necessary for the retaining wall and leave approximately 100 feet of river frontage in your ownership; and the Contractor will use an erosion control barrier or silt fence along the property line at the property owned by Lance and Helena Sue Harrod (Sta. 633+00 to Sta. 634+75). These commitments were made by the project engineer.
26. A commitment was made to the Oregon Postmaster regarding the relocation of mailboxes. All mailboxes affected by the project shall be relocated on the approach side of the entrance they serve. Any questions shall be directed to the Oregon Postmaster at 815/732-2418. This commitment was made by the project engineer.
27. Commitments were made to the Presbytery of Blackhawk of the Presbyterian Church (U.S.A.) regarding their river access. See the "Commitment File". These commitments were made by the Land Acquisition Representative.
28. The Contractor shall contact the District Landscape Architect regarding placement of Prairie Restoration signs in the areas with Seeding, Class 4. This commitment was made by the Project Engineer.
29. A commitment was made to Michael K. and Linda A. Connelly (Lt. & Rt. Sta. 605+00) stating that state employees and contractor employees shall not trespass on private steps, decks or docks and shall work around improvements in the temporary easement areas. This commitment was made by the Land Acquisition Representative.
30. A commitment was made to Dallas A. Huntley regarding informational signs. See the "Commitment File". This commitment was made by the Land Acquisition Representative.
31. A commitment was made to Dorothy E. Cultra regarding her field entrance. The Department will construct the field entrance at a 13% grade with an HMA surface to the existing State right-of-way, then transition to aggregate for the remainder of the field entrance. See "Commitment File" for Temporary Use Permit. This commitment was made by the Land Acquisition Representative.
32. Commitment were made to Harry E. and Karly Spell (Lt. & Rt. Sta. 625+00) regarding trees and their entrance. See the "Commitment File". Proposed flare will need to be adjusted by the Resident Engineer to match and align with the new concrete driveway. These commitments were made by the Land Acquisition Representative.
33. A commitment was made to Steven and Cynthia Wennmaker (Lt. & Rt. Sta. 610+00) regarding trees. See the "Commitment File". This commitment was made by the Land Acquisition Representative.

Program #5  
(Arch. Size)  
Enlarge  
200%  
Enlarge 107%

STRUCTURAL DESIGN INFORMATION - RIGID PAVEMENT		
STRUCTURAL DESIGN TRAFFIC:	YEAR	2015
PV =	8920	SU = 340 MU = 390
ROAD/STREET CLASSIFICATION:	Class	II
PERCENT OF STRUCTURAL DESIGN TRAFFIC IN DESIGN LANE:		
P =	50	S = 50 M = 50
TRAFFIC FACTOR:	Actual TF =	5.51
MINIMUM SOIL SUPPORT:		
IBR =	2	(Sta. 603+08 to Sta. 680+00)

# TYPICAL SECTIONS

STA. 603+07.85 - 603+50

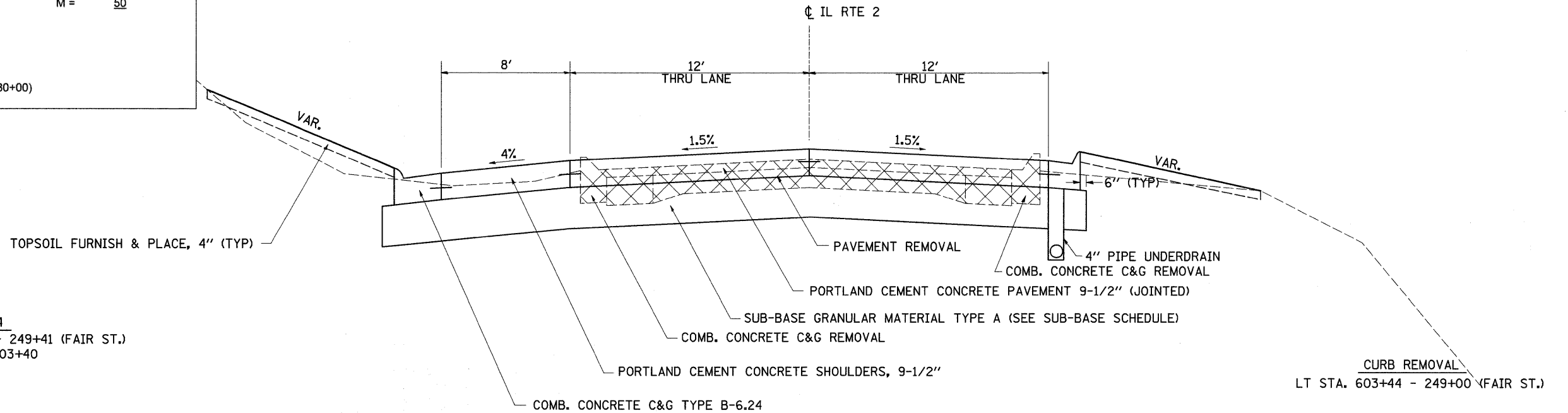

CC&G, TYPE B-6.24  
 LT STA. 603+07.85 - 249+41 (FAIR ST.)  
 RT STA. 603+08 - 603+40

CURB REMOVAL  
 LT STA. 603+44 - 249+00 (FAIR ST.)

COMBINATION CURB AND GUTTER REMOVAL  
 LT STA. 603+08 - 603+44  
 RT STA. 603+08 - 603+80

**PROTECTIVE COAT:**  
 IF CURB AND GUTTER OR PCC PAVEMENT IS CONSTRUCTED AFTER OCTOBER 15TH AND THE ROAD WILL BE OPEN TO TRAFFIC PRIOR TO THE FOLLOWING APRIL 15TH, PROTECTIVE COAT SHALL BE INSTALLED.

STA. 603+50 - 612+05 S.E.=2.4%

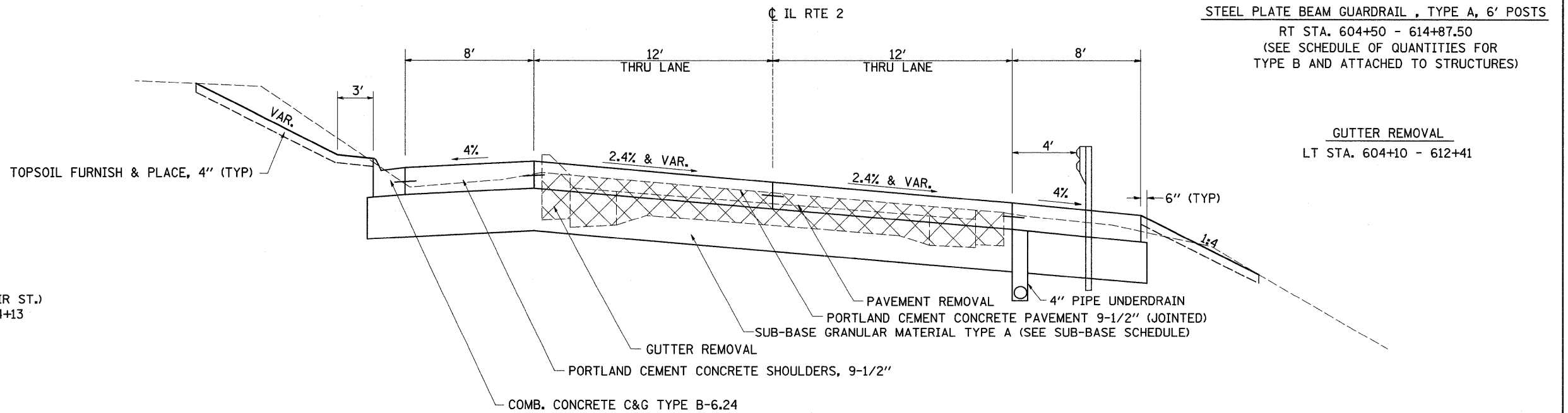

STEEL PLATE BEAM GUARDRAIL, TYPE A, 6' POSTS  
 RT STA. 604+50 - 614+87.50  
 (SEE SCHEDULE OF QUANTITIES FOR TYPE B AND ATTACHED TO STRUCTURES)

GUTTER REMOVAL  
 LT STA. 604+10 - 612+41

CC&G, TYPE B-6.24  
 LT STA. 604+13 - 612+50  
 LT STA. 603+07.85 - 249+41 (FAIR ST.)  
 LT STA. 249+00 (FAIR ST.) - 604+13

FILE NAME =	USER NAME = cushmanbw	DESIGNED -	REVISED -
ct:\pw\work\VP\WIDOT\CUSHMANBW\dms34123\dms34123\6486typ69.dgn		DRAWN -	REVISED -
PLOT SCALE = 50.0000' / IN.		CHECKED -	REVISED -
PLOT DATE = Thu Apr 30 14:52:07 2009		DATE -	REVISED -

STATE OF ILLINOIS  
 DEPARTMENT OF TRANSPORTATION

## TYPICAL SECTIONS

SCALE: SHEET NO. OF SHEETS STA. TO STA.

F.A.P. RTE.	SECTION	COUNTY	TOTAL SHEETS	SHEET NO.
742	37R-3	OGLE	345	13
FED. ROAD DIST. NO. ILLINOIS FED. AID PROJECT			CONTRACT NO. 84788	

# TYPICAL SECTIONS

STA. 612+05 - 614+56

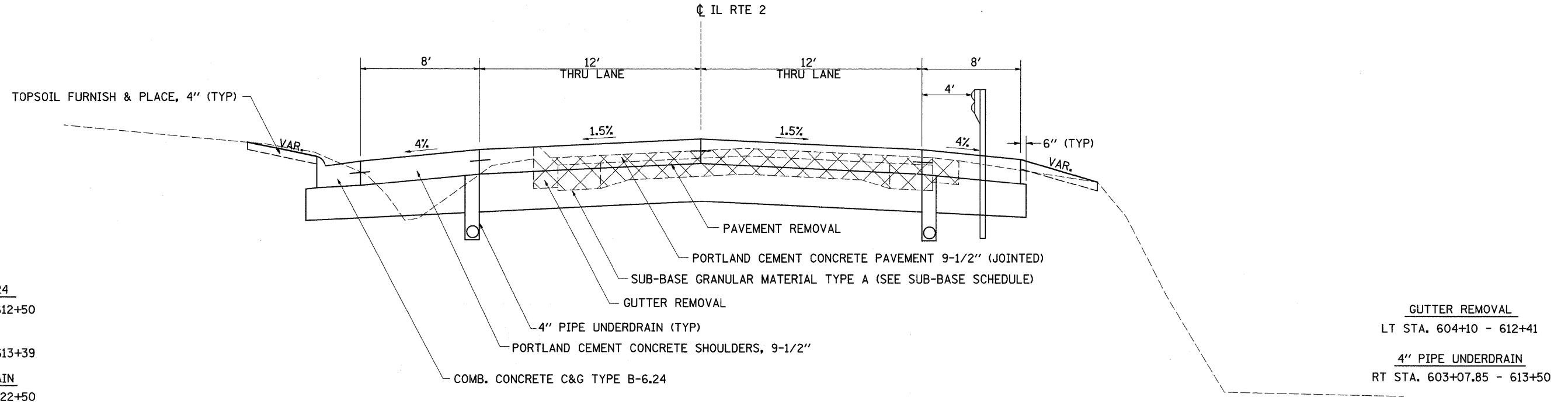

CC&G, TYPE B-6.24  
 LT STA. 604+13 - 612+50  
DITCH  
 LT STA. 613+00 - 613+39  
4" PIPE UNDERDRAIN  
 LT STA. 611+00 - 622+50

GUTTER REMOVAL  
 LT STA. 604+10 - 612+41  
4" PIPE UNDERDRAIN  
 RT STA. 603+07.85 - 613+50

PROTECTIVE COAT:  
 IF CURB AND GUTTER OR PCC PAVEMENT IS CONSTRUCTED AFTER OCTOBER 15TH AND THE ROAD WILL BE OPEN TO TRAFFIC PRIOR TO THE FOLLOWING APRIL 15TH, PROTECTIVE COAT SHALL BE INSTALLED.

STEEL PLATE BEAM GUARDRAIL, TYPE A, 6' POSTS  
 RT STA. 604+50 - 614+87.50  
 RT STA. 615+56.25 - 626+31.25  
 (SEE SCHEDULE OF QUANTITIES FOR TYPE B AND ATTACHED TO STRUCTURES)

STA. 614+56 - 621+35 S.E.=3.4%

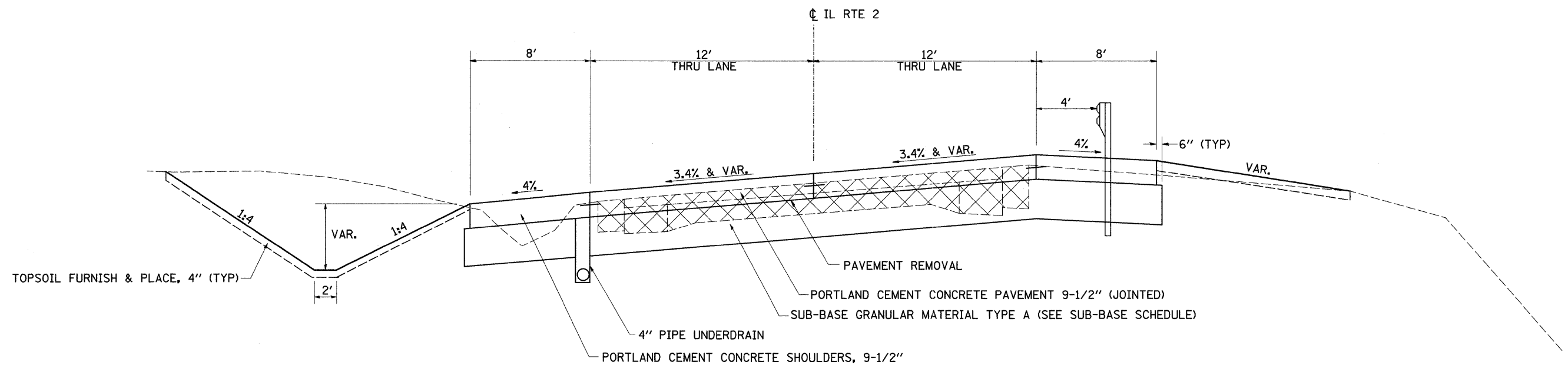

FILE NAME =	USER NAME = cushmanbw	DESIGNED -	REVISED -
ct:\pw_work\VPWIDOT\CUSHMANBW\dms34123\6486typ69.dgn		DRAWN -	REVISED -
PLOT SCALE = 50.0000' / IN.		CHECKED -	REVISED -
PLOT DATE = Thu Apr 30 14:52:10 2009		DATE -	REVISED -

STATE OF ILLINOIS  
 DEPARTMENT OF TRANSPORTATION

## TYPICAL SECTIONS

SCALE: SHEET NO. OF SHEETS STA. TO STA.

F.A.P. RTE. 742	SECTION 37R-3	COUNTY OGLE	TOTAL SHEETS 345	SHEET NO. 14
FED. ROAD DIST. NO. ILLINOIS FED. AID PROJECT			CONTRACT NO. 84788	

# TYPICAL SECTIONS

STA. 621+35 - 626+34

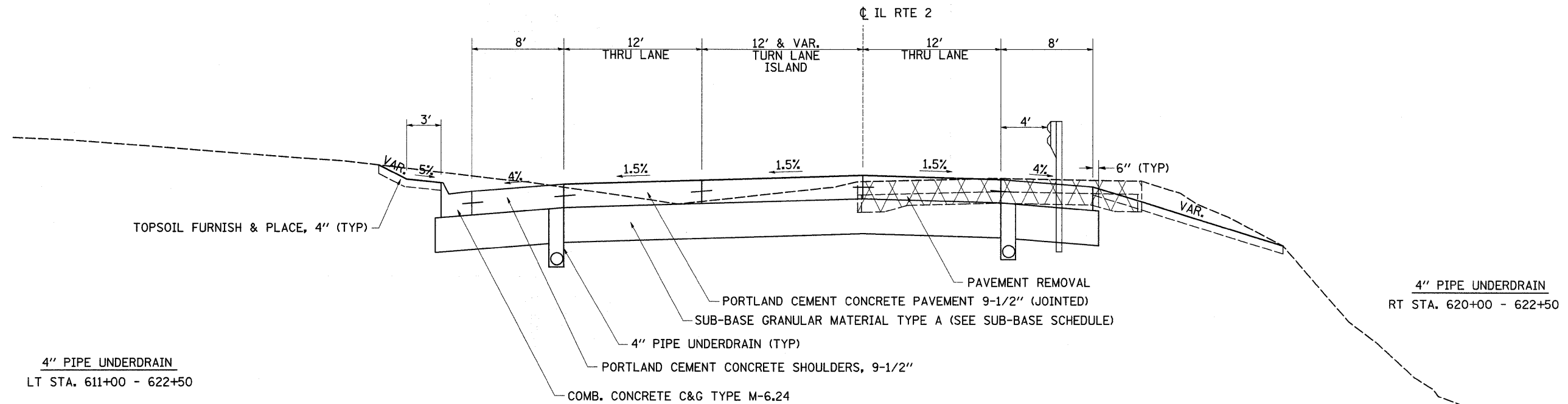

**PROTECTIVE COAT:**

IF CURB AND GUTTER OR PCC PAVEMENT IS CONSTRUCTED AFTER OCTOBER 15TH AND THE ROAD WILL BE OPEN TO TRAFFIC PRIOR TO THE FOLLOWING APRIL 15TH, PROTECTIVE COAT SHALL BE INSTALLED.

STA. 626+34 - 628+06 S.E.=3.8%  
 STA. 643+19 - 648+57 S.E.=5.6%  
 STA. 648+57 - 656+69 S.E.=5.6%

**STEEL PLATE BEAM GUARDRAIL, TYPE A, 6' POSTS**

RT STA. 615+56.25 - 626+31.25  
 RT STA. 626+93.75 - 630+06.25  
 (SEE SCHEDULE OF QUANTITIES FOR TYPE B AND ATTACHED TO STRUCTURES)

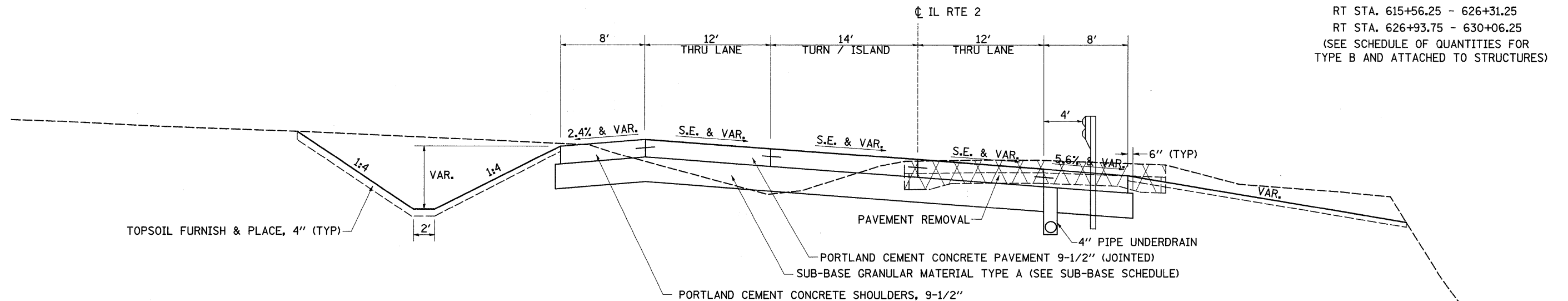

FILE NAME =	USER NAME = cushmanbw	DESIGNED -	REVISED -
os:\pw_work\PWIDOT\CUSHMANBW\dms34123\6486typ69.dgn		DRAWN -	REVISED -
PLOT SCALE = 50,0000' / IN.		CHECKED -	REVISED -
PLOT DATE = Thu Apr 30 14:52:11 2009		DATE -	REVISED -

STATE OF ILLINOIS  
 DEPARTMENT OF TRANSPORTATION

## TYPICAL SECTIONS

SCALE: SHEET NO. OF SHEETS STA. TO STA.

F.A.P. RTE.	SECTION	COUNTY	TOTAL SHEETS	SHEET NO.
742	37R-3	OGLE	345	15
CONTRACT NO. 84788				
FED. ROAD DIST. NO. ILLINOIS FED. AID PROJECT				

# TYPICAL SECTIONS

STA. 628+06 - 631+47

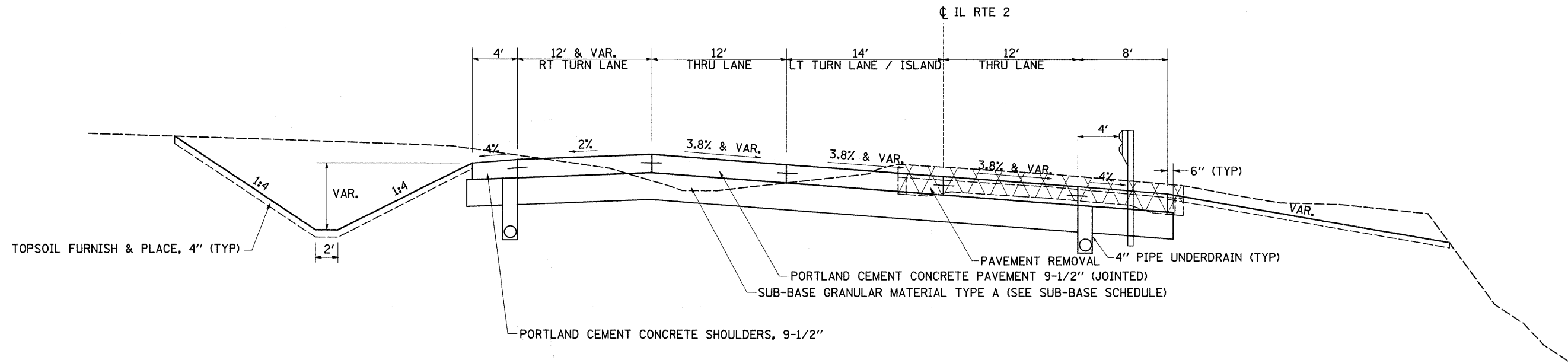

**PROTECTIVE COAT:**

IF CURB AND GUTTER OR PCC PAVEMENT IS CONSTRUCTED AFTER OCTOBER 15TH AND THE ROAD WILL BE OPEN TO TRAFFIC PRIOR TO THE FOLLOWING APRIL 15TH, PROTECTIVE COAT SHALL BE INSTALLED.

**STEEL PLATE BEAM GUARDRAIL, TYPE A, 6' POSTS**

RT STA. 626+93.75 - 630+06.25

RT STA. 630+06.25 - 637+08

(SEE SCHEDULE OF QUANTITIES FOR TYPE B AND ATTACHED TO STRUCTURES)

STA. 631+47 - 638+73

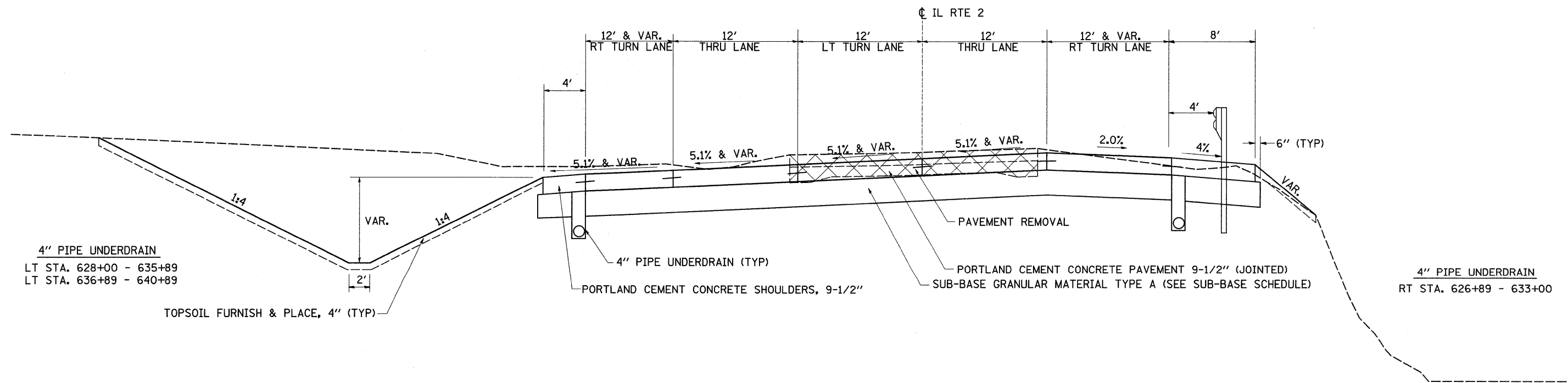

4" PIPE UNDERDRAIN  
RT STA. 626+89 - 633+00

FILE NAME =	USER NAME = cushmanbw	DESIGNED -	REVISED -	<b>STATE OF ILLINOIS DEPARTMENT OF TRANSPORTATION</b>	<b>TYPICAL SECTIONS</b>	F.A.P. RTE.	SECTION	COUNTY	TOTAL SHEETS	SHEET NO.	
ca:\pwwork\pwwid01\CUSHMANBW\dms34123\dms6486typ69.dgn	PLOT SCALE = 50.0000' / IN.	DRAWN -	REVISED -			742	37R-3	OGLE	345	16	
	PLOT DATE = Thu Apr 30 14:52:13 2009	CHECKED -	REVISED -			CONTRACT NO. 84788					
		DATE -	REVISED -			SCALE:	SHEET NO.	OF SHEETS	STA.	TO STA.	FED. ROAD DIST. NO.



# TYPICAL SECTIONS

STA. 638+73 - 643+19

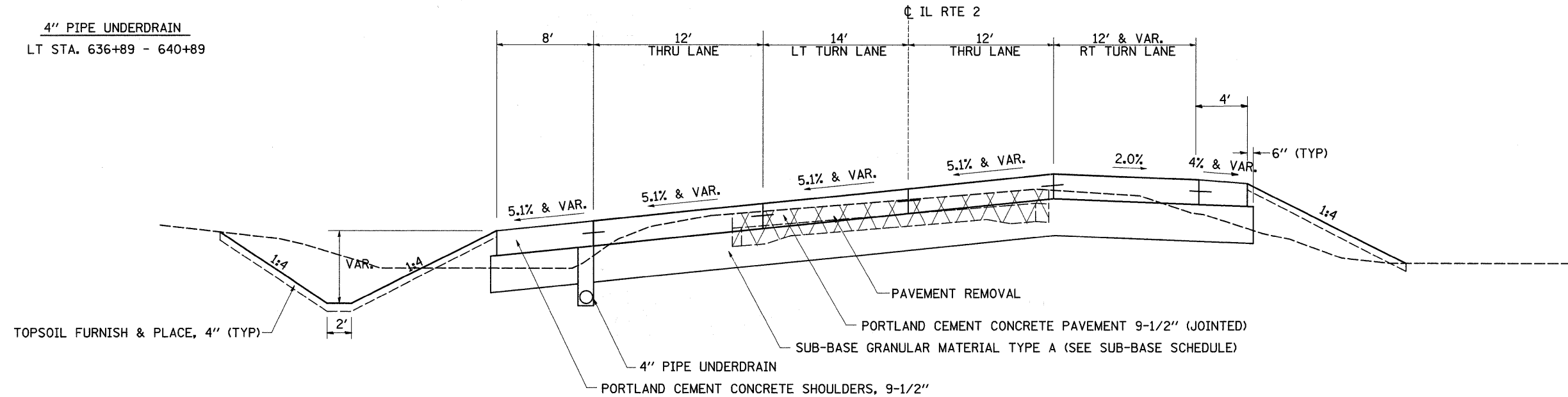

**PROTECTIVE COAT:**

IF CURB AND GUTTER OR PCC PAVEMENT IS CONSTRUCTED AFTER OCTOBER 15TH AND THE ROAD WILL BE OPEN TO TRAFFIC PRIOR TO THE FOLLOWING APRIL 15TH, PROTECTIVE COAT SHALL BE INSTALLED.

STA. 656+69 - 661+75  
STA. 671+00 - 677+04

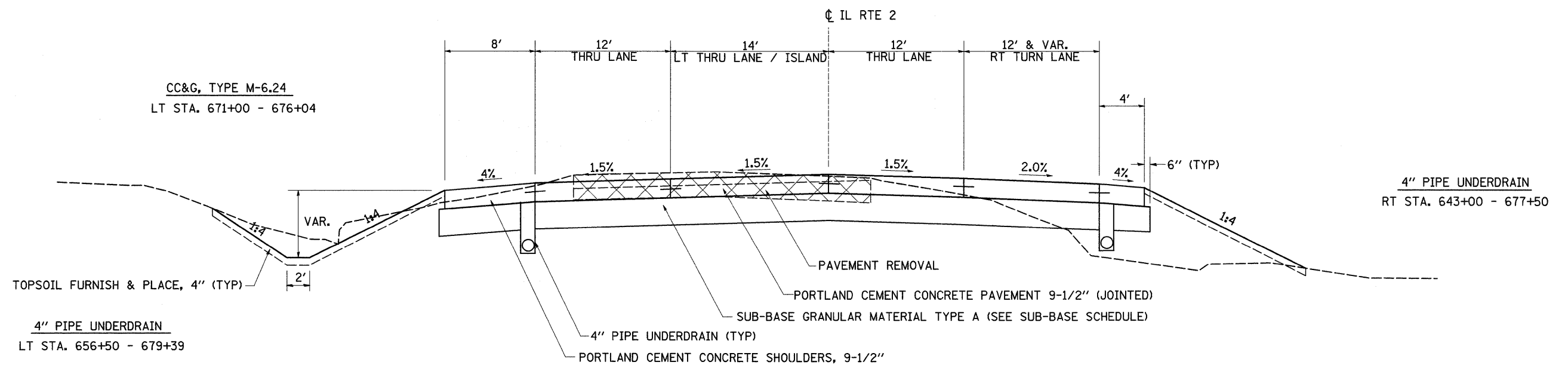

FILE NAME =	USER NAME = cushmanbw	DESIGNED -	REVISED -	<b>STATE OF ILLINOIS DEPARTMENT OF TRANSPORTATION</b>	<b>TYPICAL SECTIONS</b>	F.A.P. RTE.	SECTION	COUNTY	TOTAL SHEETS	SHEET NO.
ct:\pw_work\PIWIDOT\CUSHMANBW\dms34123\6486typ69.dgn		DRAWN -	REVISED -			742	37R-3	OGLE	345	17
PLOT SCALE = 50.0000' / IN.		CHECKED -	REVISED -			CONTRACT NO. 84788				
PLOT DATE = Thu Apr 30 14:52:14 2009		DATE -	REVISED -			FED. ROAD DIST. NO. [ILLINOIS] FED. AID PROJECT				
SCALE: SHEET NO. OF SHEETS STA. TO STA.										

# TYPICAL SECTIONS

STA. 661+75 - 671+00

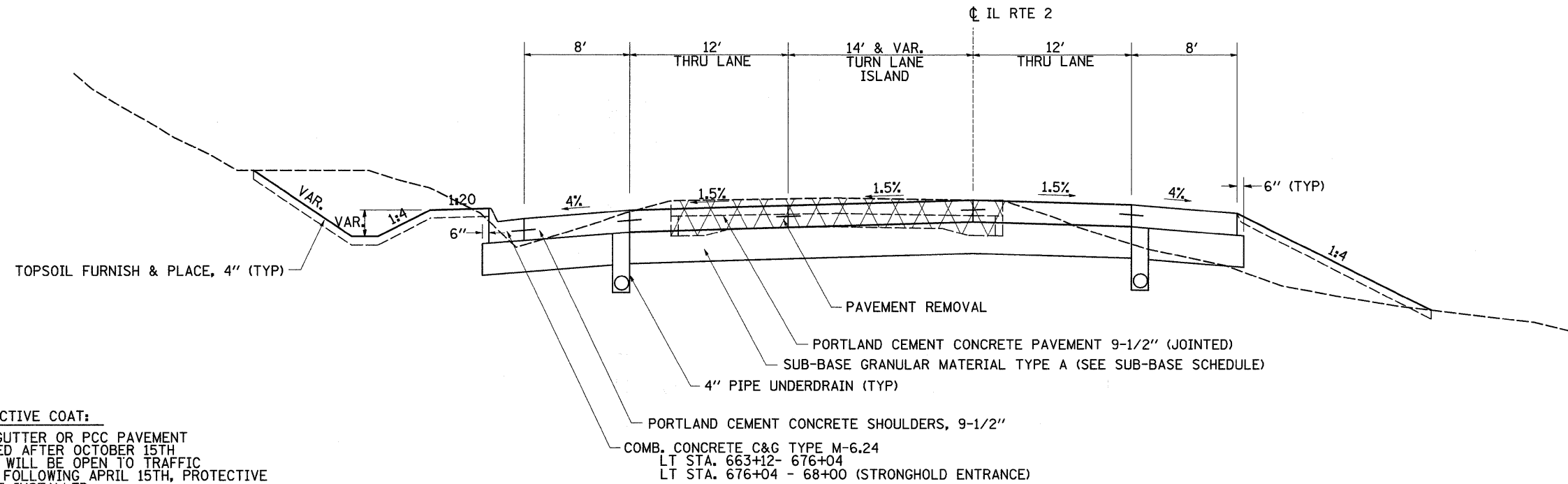

STA. 673+17 - 675+22

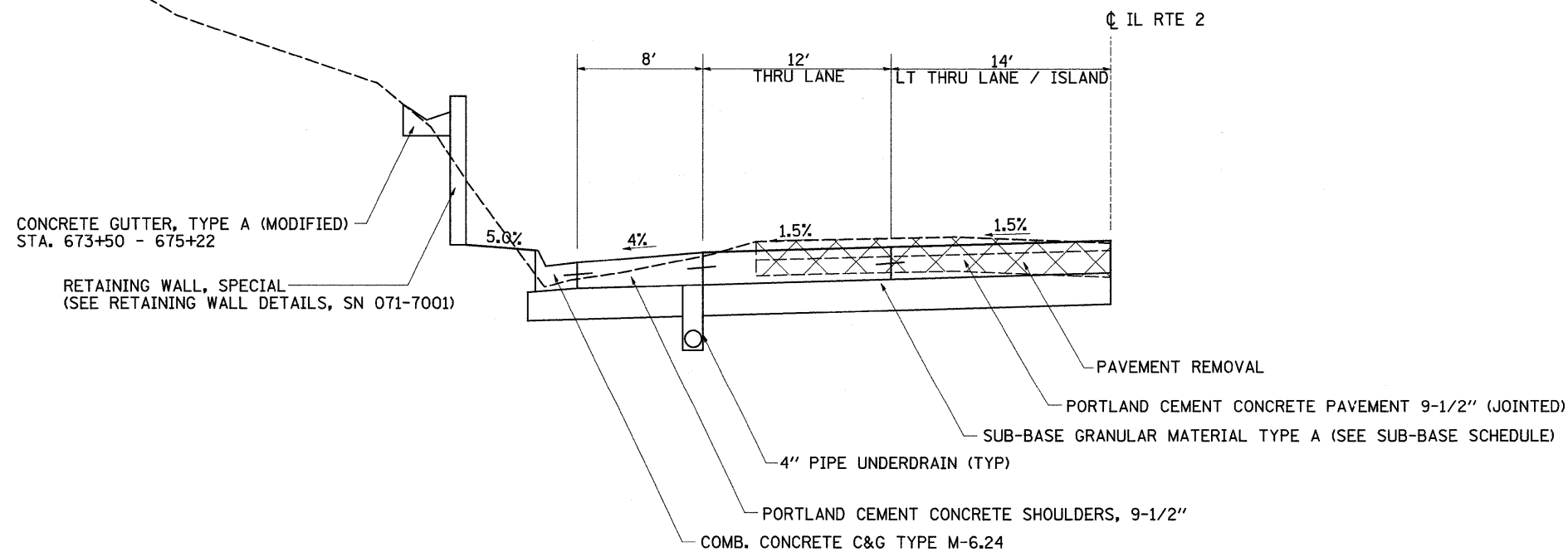

FILE NAME =	USER NAME = cushmanbw	DESIGNED -	REVISED -
ct\pwwork\PIWIDOT\CUSHMANBW\dms34123\6496typ69.dgn		DRAWN -	REVISED -
		CHECKED -	REVISED -
		DATE -	REVISED -

STATE OF ILLINOIS  
 DEPARTMENT OF TRANSPORTATION

## TYPICAL SECTIONS

SCALE: SHEET NO. OF SHEETS STA. TO STA.

F.A.P. RTE.	SECTION	COUNTY	TOTAL SHEETS	SHEET NO.
742	37R-3	OGLE	345	18
CONTRACT NO. 84788				
FED. ROAD DIST. NO. ILLINOIS FED. AID PROJECT				

# TYPICAL SECTIONS

STA. 677+04 - 680+00

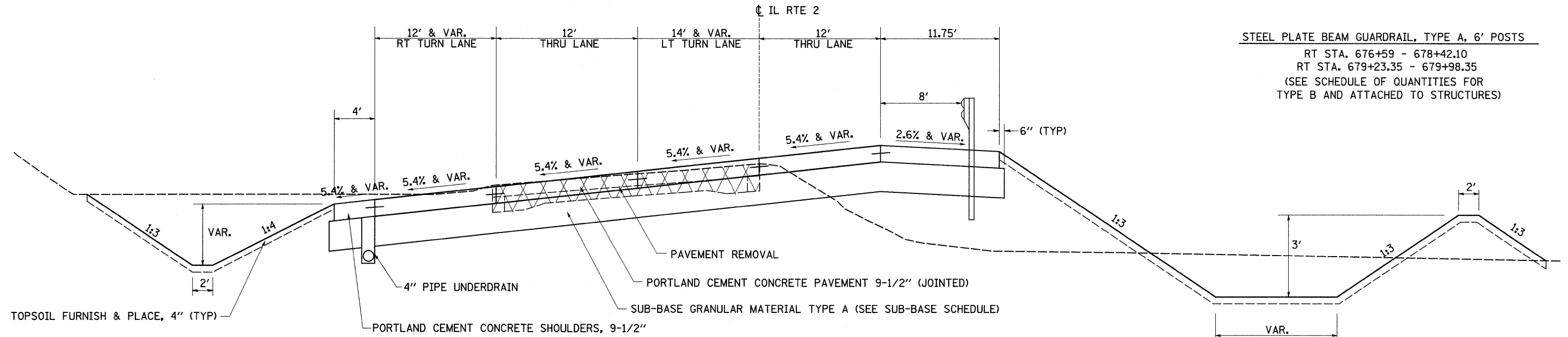

STEEL PLATE BEAM GUARDRAIL, TYPE A, 6' POSTS  
 RT STA. 676+59 - 678+42.10  
 RT STA. 679+23.35 - 679+98.35  
 (SEE SCHEDULE OF QUANTITIES FOR  
 TYPE B AND ATTACHED TO STRUCTURES)

4" PIPE UNDERDRAIN  
 LT STA. 656+50 - 679+39

**PROTECTIVE COAT:**  
 IF CURB AND GUTTER OR PCC PAVEMENT  
 IS CONSTRUCTED AFTER OCTOBER 15TH  
 AND THE ROAD WILL BE OPEN TO TRAFFIC  
 PRIOR TO THE FOLLOWING APRIL 15TH, PROTECTIVE  
 COAT SHALL BE INSTALLED.

STA. 680+00 - 684+50

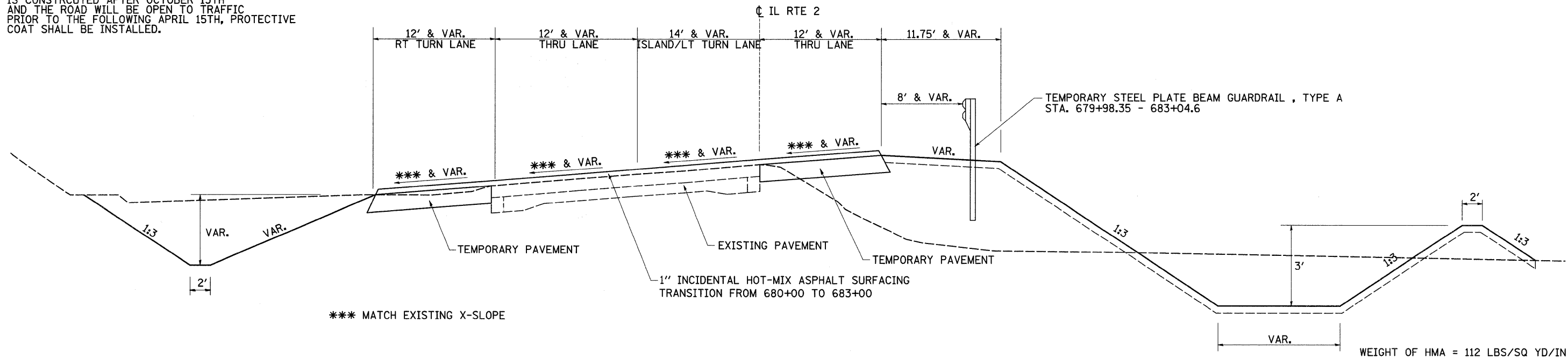

TEMPORARY STEEL PLATE BEAM GUARDRAIL, TYPE A  
 STA. 679+98.35 - 683+04.6

\*\*\* MATCH EXISTING X-SLOPE

WEIGHT OF HMA = 112 LBS/SQ YD/IN

FILE NAME =	USER NAME = oushmanbw	DESIGNED -	REVISED -
ct:\pw_work\PIWIDOT\CUSHMANBW\dms34123\dms34123.dwg	6486typ69.dgn	DRAWN -	REVISED -
PLOT SCALE = 50.0000' / IN.	CHECKED -	REVISED -	REVISED -
PLOT DATE = Thu Apr 30 14:52:16 2009	DATE -	REVISED -	REVISED -

STATE OF ILLINOIS  
 DEPARTMENT OF TRANSPORTATION

## TYPICAL SECTIONS

SCALE: SHEET NO. OF SHEETS STA. TO STA.

F.A.P. RTE	SECTION	COUNTY	TOTAL SHEETS	SHEET NO.
742	37R-3	OGLE	345	19
FED. ROAD DIST. NO. ILLINOIS FED. AID PROJECT			CONTRACT NO. 84788	

# TYPICAL SECTIONS

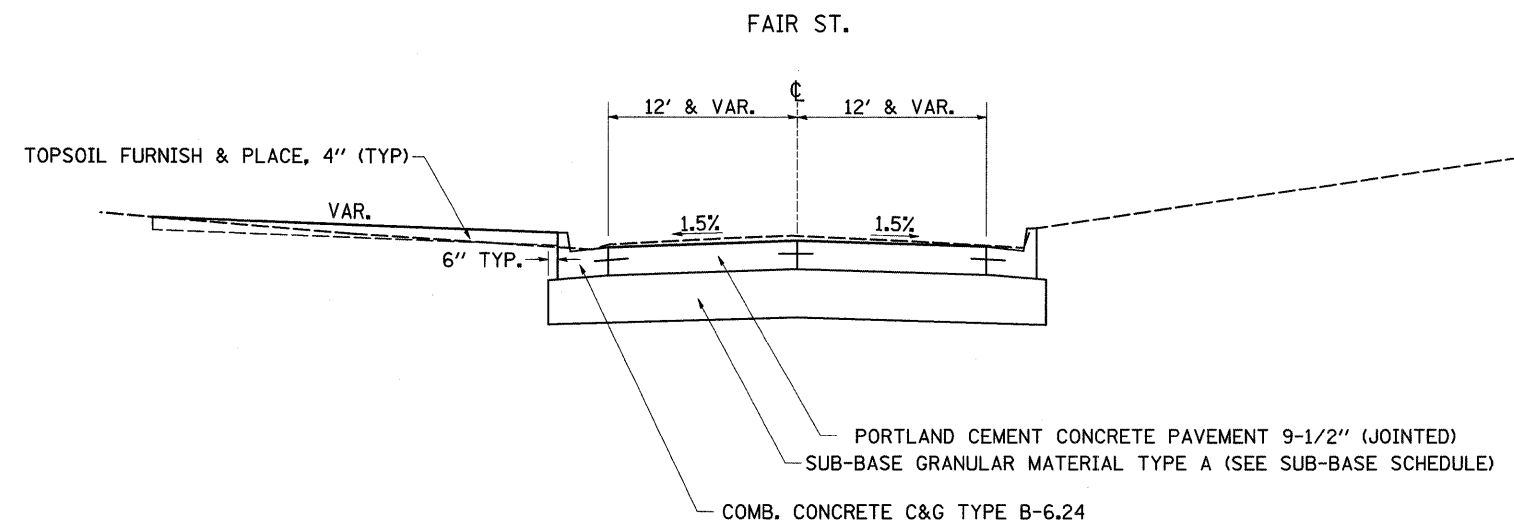

**PROTECTIVE COAT:**  
 IF CURB AND GUTTER OR PCC PAVEMENT IS CONSTRUCTED AFTER OCTOBER 15TH AND THE ROAD WILL BE OPEN TO TRAFFIC PRIOR TO THE FOLLOWING APRIL 15TH, PROTECTIVE COAT SHALL BE INSTALLED.

MARGARET FULLER DR. STA. 16+75.00 TO 18+75.76  
 BLACKHAWK VISTA STA. 27+50.00 TO 28+91.82

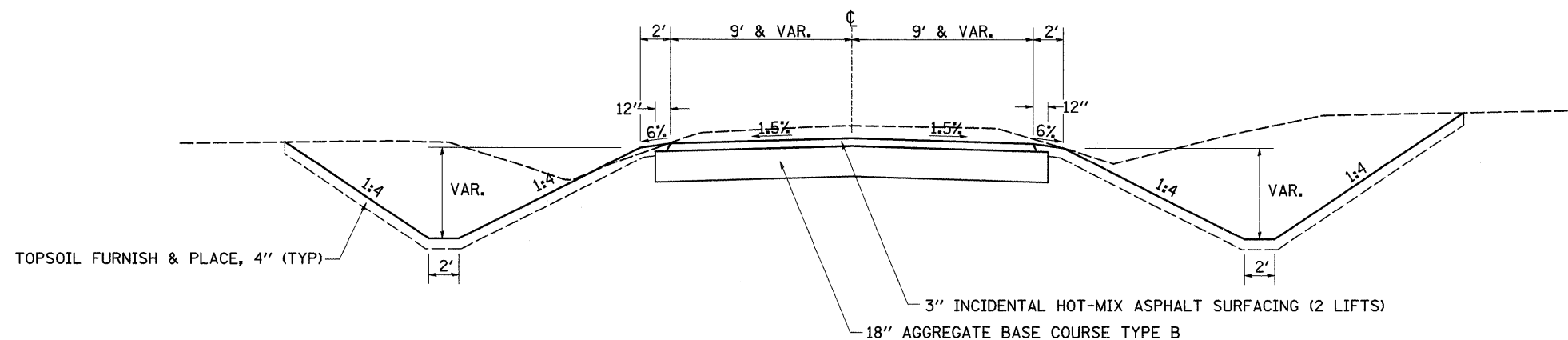

WEIGHT OF HMA = 112 LBS/SQ YD/IN

FILE NAME =	USER NAME = cushmanbw	DESIGNED -	REVISED -	<b>STATE OF ILLINOIS DEPARTMENT OF TRANSPORTATION</b>	SCALE:	SHEET NO.	OF SHEETS	STA.	TO STA.	F.A.P. RTF.	SECTION	COUNTY	TOTAL SHEETS	SHEET NO.
cd:\pw_work\VPWIDOT\CUSHMANBW\dms34123\6486typ69.dgn	DRAWN -	REVISED -	742							37R-3	OGLE	345	20	
PLOT SCALE = 50.0000' / IN.	CHECKED -	REVISED -	CONTRACT NO. 84788											
PLOT DATE = Thu Apr 30 14:52:29 2009	DATE -	REVISED -	FED. ROAD DIST. NO. [ILLINOIS] FED. AID PROJECT											

# TYPICAL SECTIONS

CARTWRIGHT LANE STA. 37+25.00 TO 38+87.04

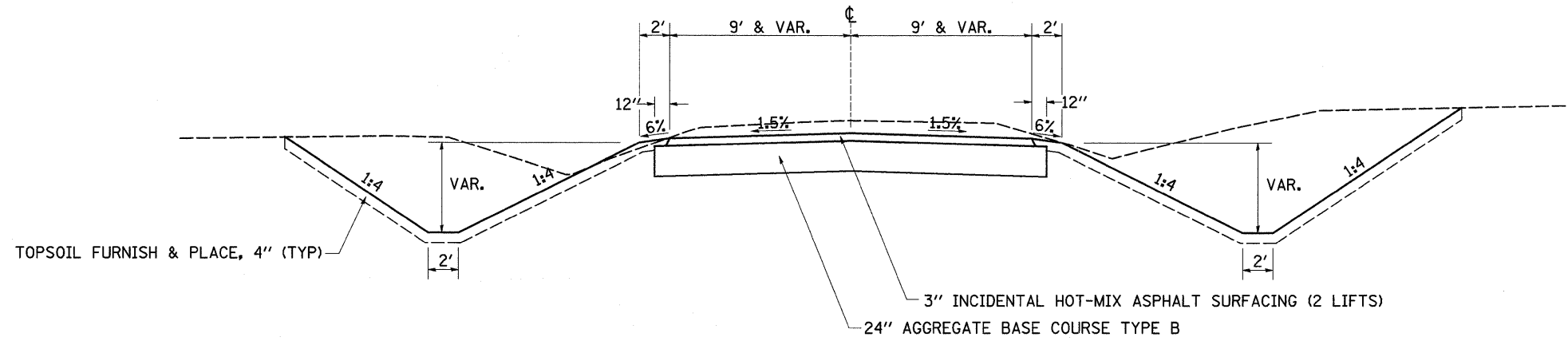

**PROTECTIVE COAT:**  
 IF CURB AND GUTTER OR PCC PAVEMENT IS CONSTRUCTED AFTER OCTOBER 15TH AND THE ROAD WILL BE OPEN TO TRAFFIC PRIOR TO THE FOLLOWING APRIL 15TH, PROTECTIVE COAT SHALL BE INSTALLED.

ACCESS RD. A

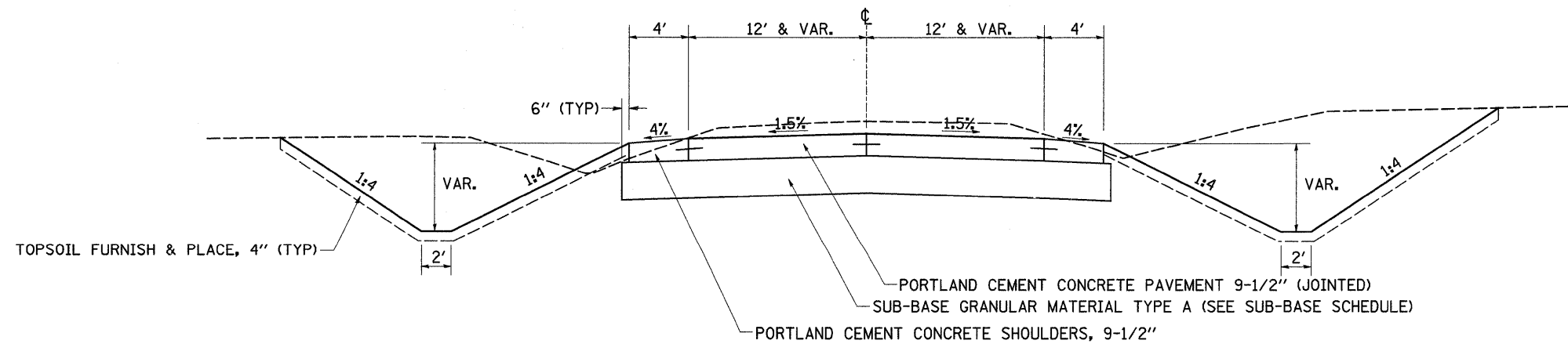

WEIGHT OF HMA = 112 LBS/SQ YD/IN

FILE NAME =	USER NAME = cushmanbw	DESIGNED -	REVISED -	<b>STATE OF ILLINOIS DEPARTMENT OF TRANSPORTATION</b>	SCALE:	SHEET NO. OF SHEETS STA. TO STA.	F.A.P. RTE.	SECTION	COUNTY	TOTAL SHEETS	SHEET NO.
ct:\pw_work\PWIDOT\CUSHMANBW\dms34123\vd6486typ69.dgn	DRAWN -	REVISED -	742				37R-3	OGLE	345	21	
PLOT SCALE = 50.0000' / IN.	CHECKED -	REVISED -	CONTRACT NO. 84788								
PLOT DATE = Thu Apr 30 14:52:28 2009	DATE -	REVISED -	FED. ROAD DIST. NO. ILLINOIS FED. AID PROJECT								

# TYPICAL SECTIONS

ACCESS RD. B STA. 50+85.00 TO 52+42.00

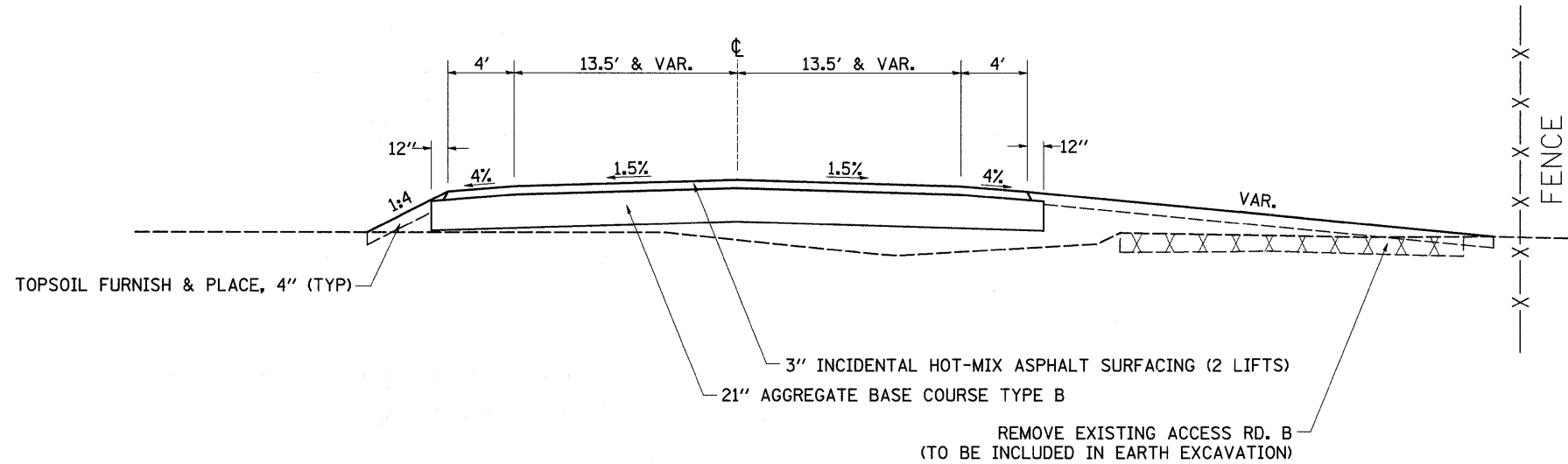

**PROTECTIVE COAT:**

IF CURB AND GUTTER OR PCC PAVEMENT IS CONSTRUCTED AFTER OCTOBER 15TH AND THE ROAD WILL BE OPEN TO TRAFFIC PRIOR TO THE FOLLOWING APRIL 15TH, PROTECTIVE COAT SHALL BE INSTALLED.

CULTRA DR.

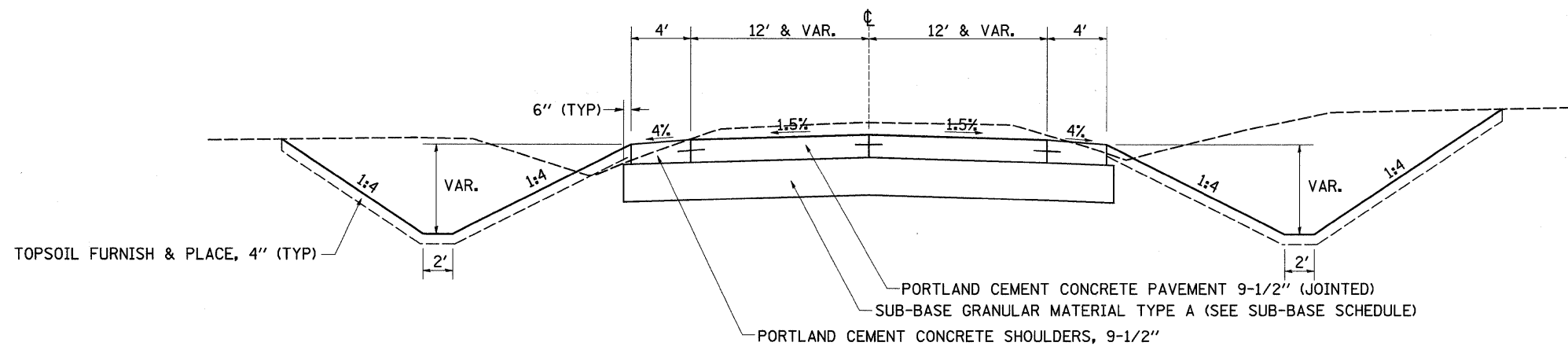

WEIGHT OF HMA = 112 LBS/SQ YD/IN

FILE NAME =	USER NAME = cushmanbw	DESIGNED -	REVISED -	<b>STATE OF ILLINOIS DEPARTMENT OF TRANSPORTATION</b>	<b>TYPICAL SECTIONS</b>	F.A.P. RTE. 742	SECTION 37R-3	COUNTY OGLE	TOTAL SHEETS 345	SHEET NO. 22	
ct:\pw_work\VPWIDOT\CUSHMANBW\dms34123\06486typ69.dgn	PLOT SCALE = 50.0000' / IN.	DRAWN -	REVISED -			SCALE:	SHEET NO. OF SHEETS	STA. TO STA.	FED. ROAD DIST. NO.	ILLINOIS FED. AID PROJECT	CONTRACT NO. 84788
	PLOT DATE = Thu Apr 30 14:52:17 2009	CHECKED -	REVISED -								
		DATE -	REVISED -								

# TYPICAL SECTIONS

STRONGHOLD ENTRANCE STA. 68+00.00 TO 68+96.13

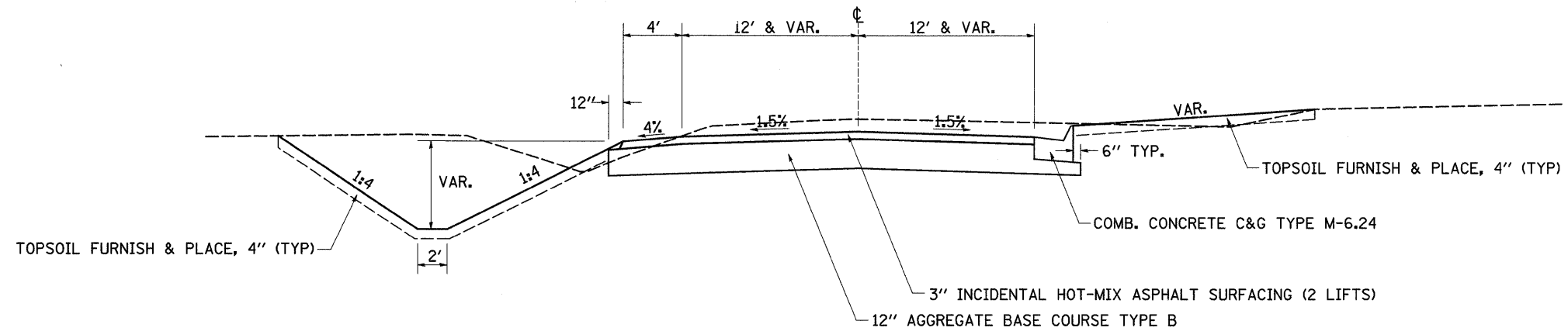

BOAT RAMP ENTRANCE STA. 70+50.00 TO 70+83.82

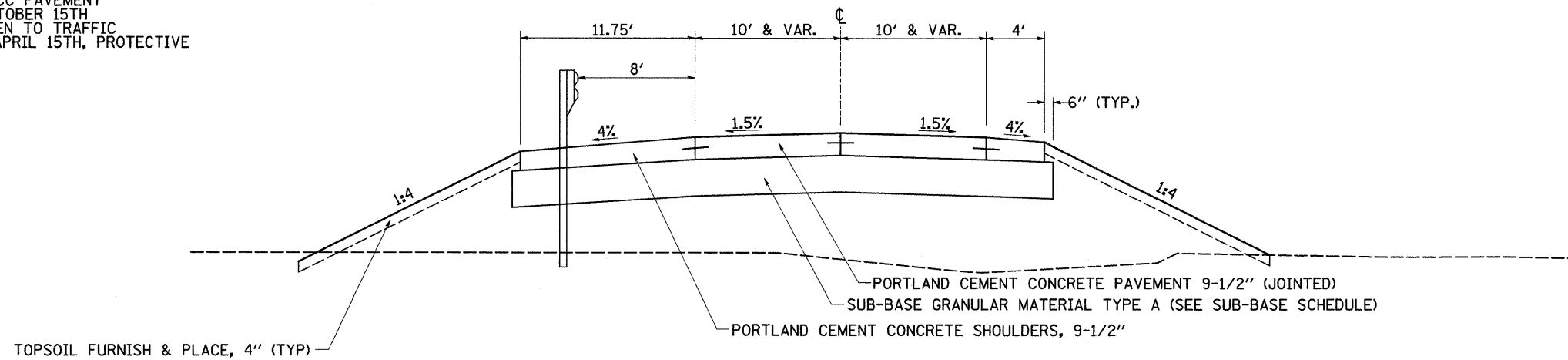

BOAT RAMP ENTRANCE STA. 70+83.82 TO 71+72.00  
(COMMITMENT FOR AGGREGATE ENTRANCE)

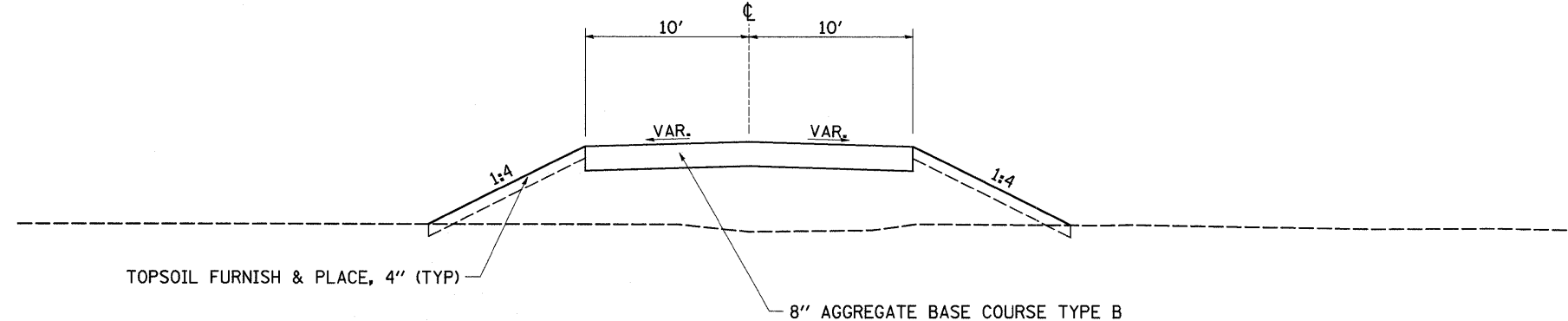

**PROTECTIVE COAT:**  
IF CURB AND GUTTER OR PCC PAVEMENT IS CONSTRUCTED AFTER OCTOBER 15TH AND THE ROAD WILL BE OPEN TO TRAFFIC PRIOR TO THE FOLLOWING APRIL 15TH, PROTECTIVE COAT SHALL BE INSTALLED.

WEIGHT OF HMA = 112 LBS/SQ YD/IN

FILE NAME =	USER NAME = cushmanbw	DESIGNED -	REVISED -	<b>STATE OF ILLINOIS DEPARTMENT OF TRANSPORTATION</b>	<b>TYPICAL SECTIONS</b>	F.A.P. RTE.	SECTION	COUNTY	TOTAL SHEETS	SHEET NO.	
cd:\pw_work\VPWIDOT\CUSHMANBW\dms34123\6486typ69.dgn		DRAWN -	REVISED -			742	37R-3	OGLE	345	23	
PLOT SCALE = 50,0000' / IN.		CHECKED -	REVISED -			CONTRACT NO. 84788					
PLOT DATE = Thu Apr 30 14:52:20 2009		DATE -	REVISED -			FED. ROAD DIST. NO. ILLINOIS FED. AID PROJECT					
					SCALE:	SHEET NO. OF SHEETS STA. TO STA.					

# TYPICAL SECTIONS

SCENIC OVERLOOK NO.1  
STA. 634+73 - 638+15

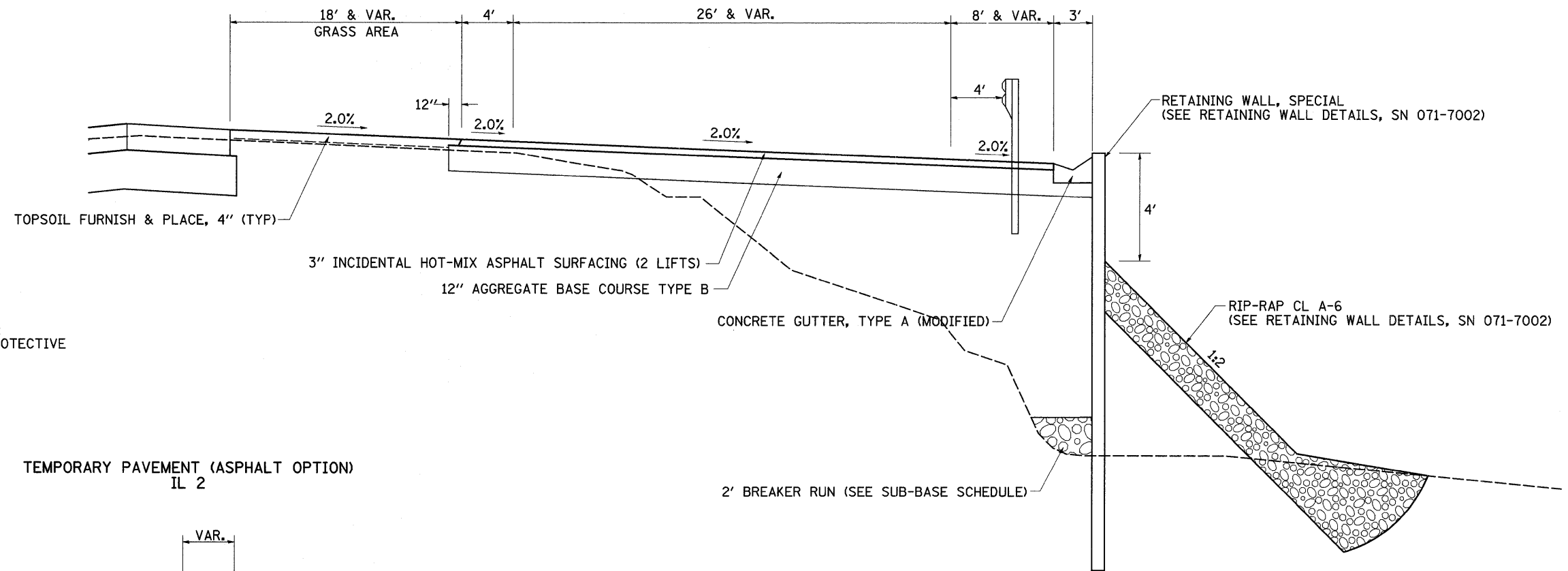

**PROTECTIVE COAT:**  
IF CURB AND GUTTER OR PCC PAVEMENT IS CONSTRUCTED AFTER OCTOBER 15TH AND THE ROAD WILL BE OPEN TO TRAFFIC PRIOR TO THE FOLLOWING APRIL 15TH, PROTECTIVE COAT SHALL BE INSTALLED.

TEMPORARY PAVEMENT (ASPHALT OPTION)  
IL 2

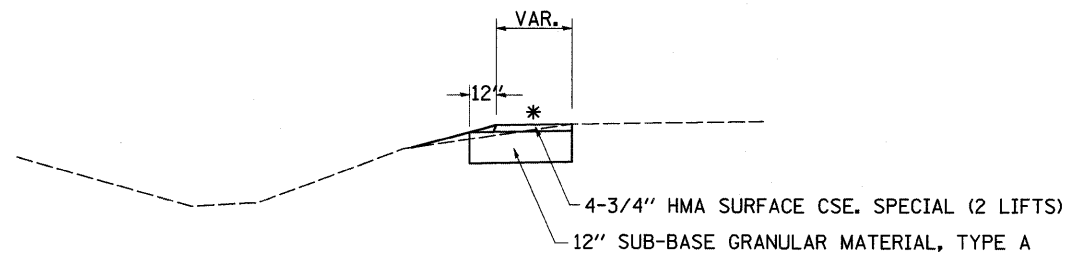

\* MATCH EXISTING CROSS SLOPE

TEMPORARY PAVEMENT (PCC OPTION)  
IL 2

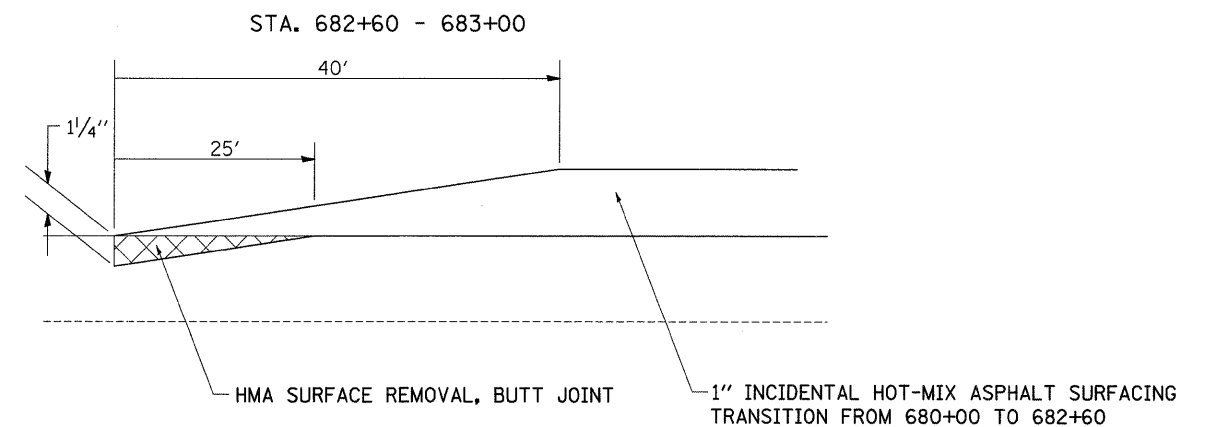
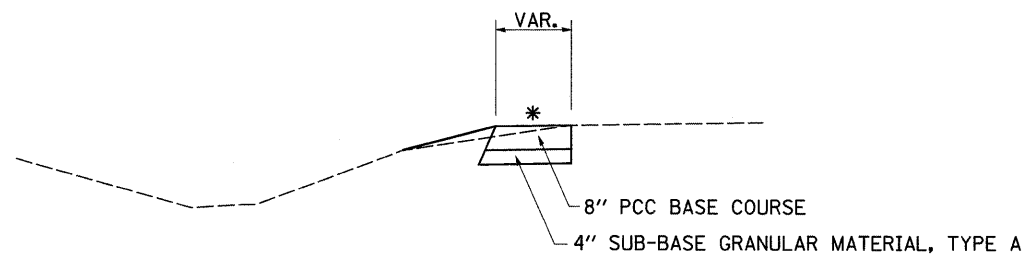

WEIGHT OF HMA = 112 LBS/SQ YD/IN

FILE NAME =	USER NAME = cushmanbw	DESIGNED -	REVISED -
ct:\pw_work\PWIDOT\CUSHMANBW\dms34123\6486typ69.dgn		DRAWN -	REVISED -
PLOT SCALE = 50.0000' / IN.		CHECKED -	REVISED -
PLOT DATE = Thu Apr 30 14:52:21 2009		DATE -	REVISED -

STATE OF ILLINOIS  
DEPARTMENT OF TRANSPORTATION

## TYPICAL SECTIONS

SCALE: SHEET NO. OF SHEETS STA. TO STA.

F.A.P. RTE. 742	SECTION 37R-3	COUNTY OGLE	TOTAL SHEETS 345	SHEET NO. 24
FED. ROAD DIST. NO. ILLINOIS FED. AID PROJECT			CONTRACT NO. 84788	



# TYPICAL SECTIONS

STA. 664+00 - 712+36  
STA. 729+37 - 752+50

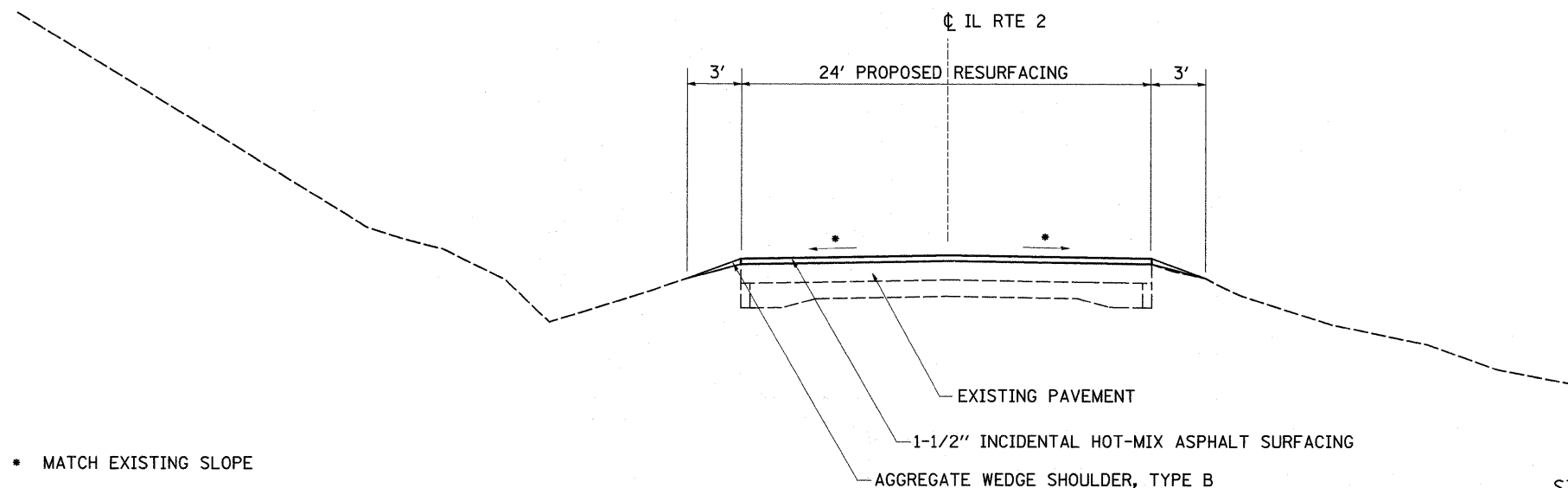

• MATCH EXISTING SLOPE

WEIGHT OF HMA = 112 LBS/SQ YD/IN

STA. 664+00 - 664+30  
STA. 712+06 - 712+36  
STA. 729+37 - 729+67  
STA. 752+20 - 752+50

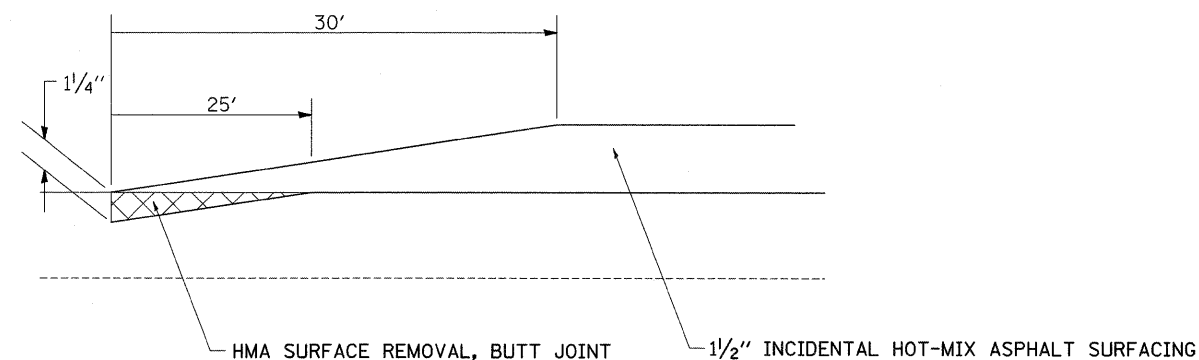

## SUPERELEVATED SECTIONS

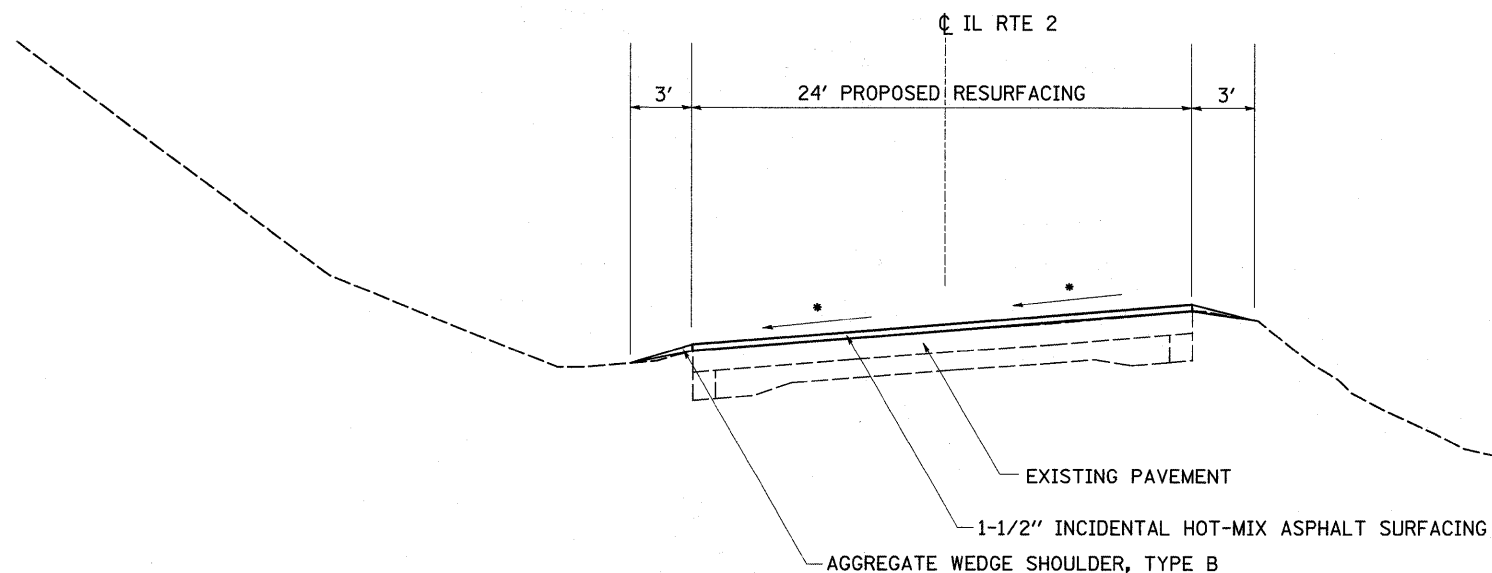

FILE NAME =	USER NAME = perkinsdr	DESIGNED -	REVISED -
ct:\pwork\pwork\perkinsdr\dms34123\dms34123.dgn	486typ69.dgn	DRAWN -	REVISED -
PLOT SCALE = 50,0000' / IN.		CHECKED -	REVISED -
PLOT DATE = Fri Jun 05 15:12:23 2009		DATE -	REVISED -

STATE OF ILLINOIS  
DEPARTMENT OF TRANSPORTATION

## TYPICAL SECTIONS

SCALE: SHEET NO. OF SHEETS STA. TO STA.

F.A.P. RTE.	SECTION	COUNTY	TOTAL SHEETS	SHEET NO.
742	37R-3	OGLE	345	24 A
FED. ROAD DIST. NO.			ILLINOIS FED. AID PROJECT	
			CONTRACT NO. 84788	

# STAGING CULVERT TYPICALS

## 6'x3' Precast Double Box Culvert

STA. 615 + 22

### STAGE 6

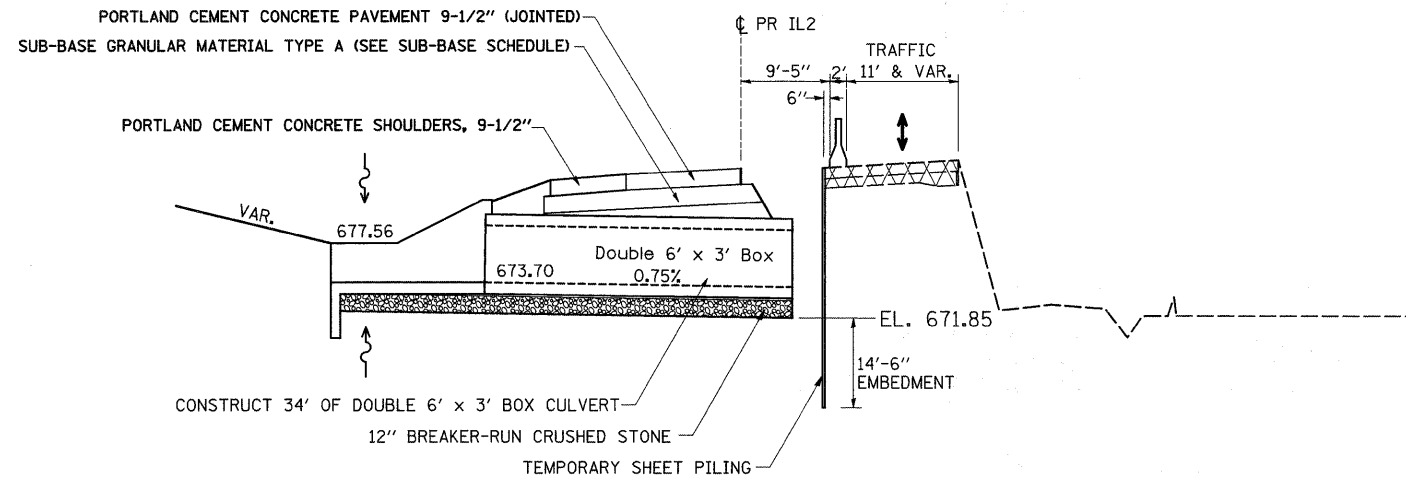

### STAGE 7

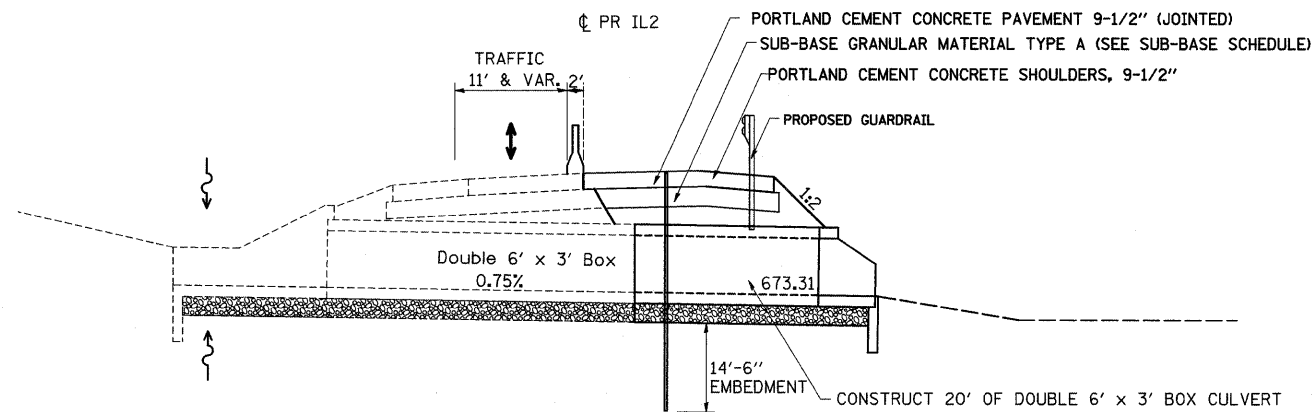

### TEMPORARY SHEET PILING

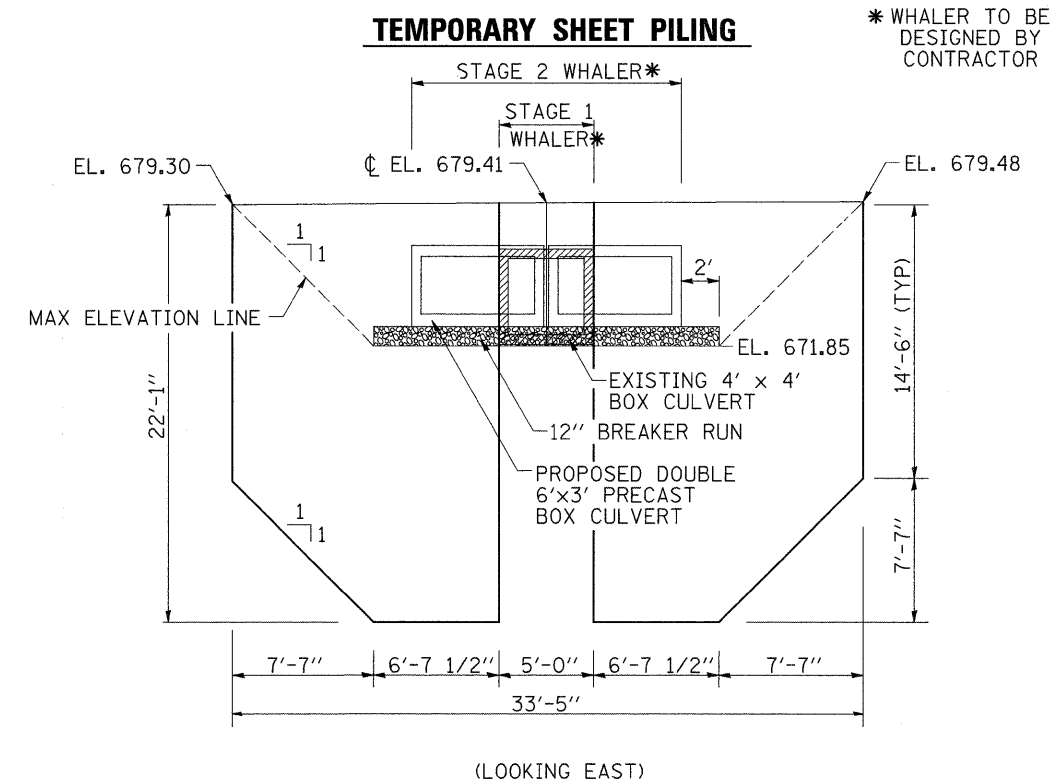

\* WHALER TO BE DESIGNED BY CONTRACTOR

TEMPORARY SHEET PILING DATA:  
 EMBEDMENT: 14'-6" BEYOND MAX. EXCAVATION (MIN.)  
 SECTION MODULUS: 11.4 in<sup>3</sup>/ft.  
 F<sub>y</sub>: 38,500 psi.

#### GENERAL NOTES:

- 1) TRAFFIC CONTROL TO BE SET UP AND PAID FOR ACCORDING TO TRAFFIC CONTROL AND PROTECTION STANDARD 701321.
- 2) THE CONTRACTOR IS RESPONSIBLE FOR MAINTAINING FLOW IN A MANNER ACCEPTABLE TO THE ENGINEER.
- 4) BARRIER WALL AND IMPACT ATTENUATORS SHALL BE SET UP AS SHOWN IN STANDARD 701321

FILE NAME =	USER NAME = cushmanbw	DESIGNED -	REVISED -	<b>STATE OF ILLINOIS DEPARTMENT OF TRANSPORTATION</b>	<b>STAGING CULVERT TYPICALS</b>	F.A.P. RTE. 742	SECTION 37R-3	COUNTY OGLE	TOTAL SHEETS 345	SHEET NO. 25		
CONTRACT NO. 84788	PLOT SCALE = 50.0000' / IN.	CHECKED -	REVISED -			SCALE:	SHEET NO. OF SHEETS STA. TO STA.	FED. ROAD DIST. NO.	ILLINOIS FED. AID PROJECT			
	PLOT DATE = Thu Apr 30 14:52:22 2009	DATE -	REVISED -									

# STAGING CULVERT TYPICALS

## Removal of 12'x3' Box Culvert

STA. 678 + 02

### STAGE 2

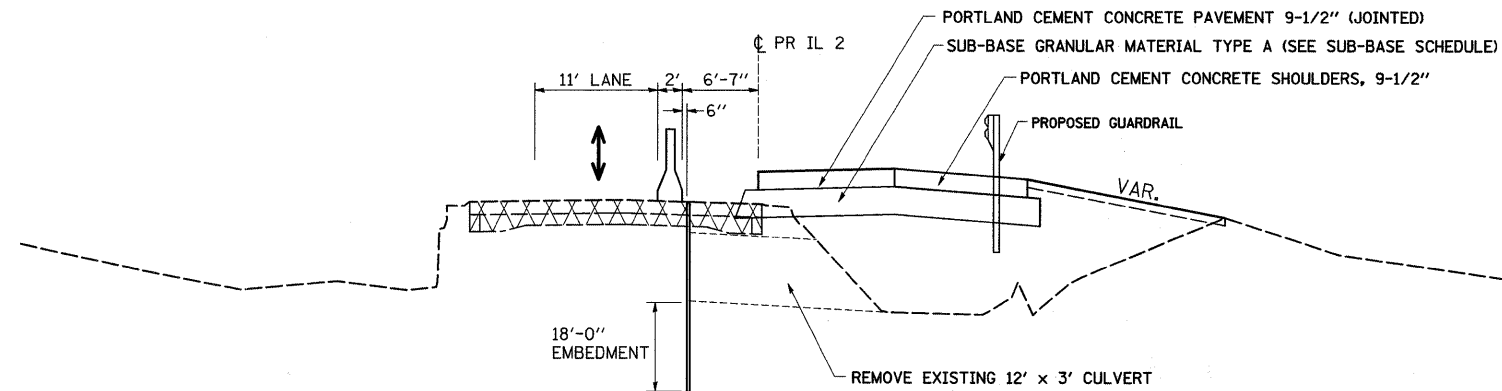

### TEMPORARY SHEET PILING

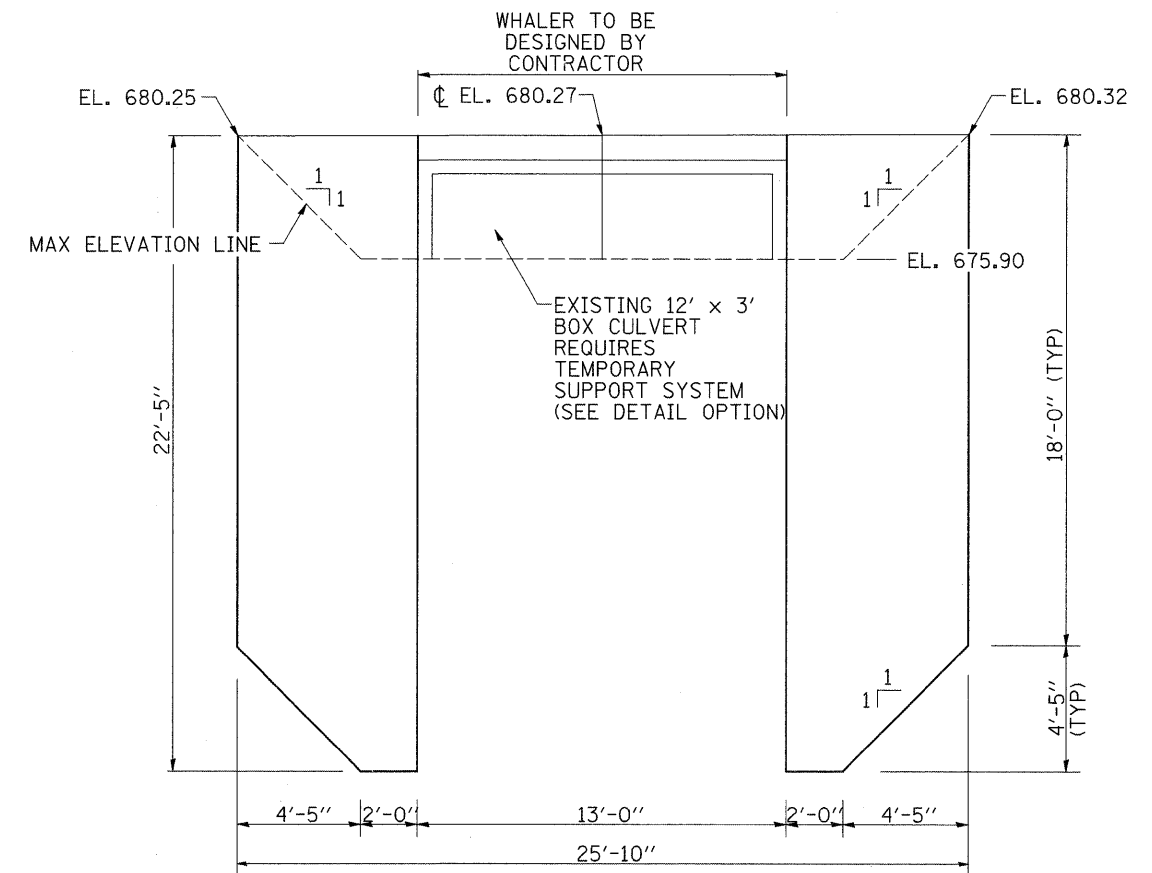

(LOOKING EAST)

#### TEMPORARY SHEET PILING DATA:

EMBEDMENT: 18'-0" BEYOND MAX. EXCAVATION  
(MIN.) SECTION MODULUS: 13.65 in<sup>2</sup>/ft.  
F<sub>y</sub>: 38,500 psi.

### STAGE 3

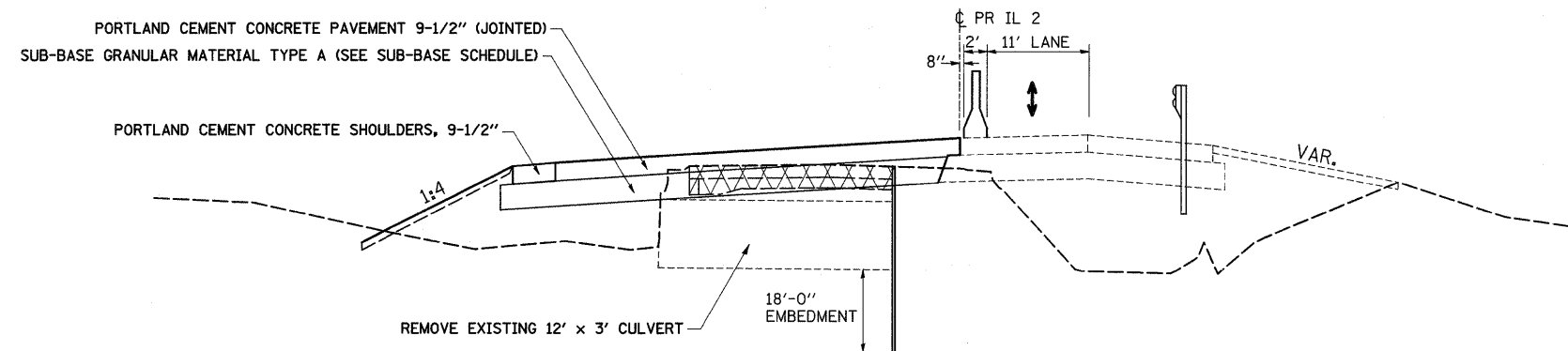

#### GENERAL NOTES:

- 1) TRAFFIC CONTROL TO BE SET UP AND PAID FOR ACCORDING TO TRAFFIC CONTROL AND PROTECTION STANDARD 701321.
- 2) THE CONTRACTOR IS RESPONSIBLE FOR MAINTAINING FLOW IN A MANNER ACCEPTABLE TO THE ENGINEER.
- 4) BARRIER WALL AND IMPACT ATTENUATORS SHALL BE SET UP AS SHOWN IN STANDARD 701321

FILE NAME =	USER NAME = cushmanbw	DESIGNED -	REVISED -	<b>STATE OF ILLINOIS DEPARTMENT OF TRANSPORTATION</b>	<b>STAGING CULVERT TYPICALS</b>			F.A.P RTE. 742	SECTION 37R-3	COUNTY OGLE	TOTAL SHEETS 345	SHEET NO. 26
es:\pw_work\PIWIDOT\CUSHMANBW\dms34123\6486typ69.dgn	PLOT SCALE = 50.0000' / IN.	DRAWN -	REVISED -					SCALE:	SHEET NO.	OF SHEETS	STA.	TO STA.
	PLOT DATE = Thu Apr 30 14:52:25 2009	CHECKED -	REVISED -									
		DATE -	REVISED -									

# STAGING CULVERT TYPICALS

## 7'x3' Double Cast-In-Place Box Culvert @ 35° Skew

### STA. 678 + 70

### STAGE 2

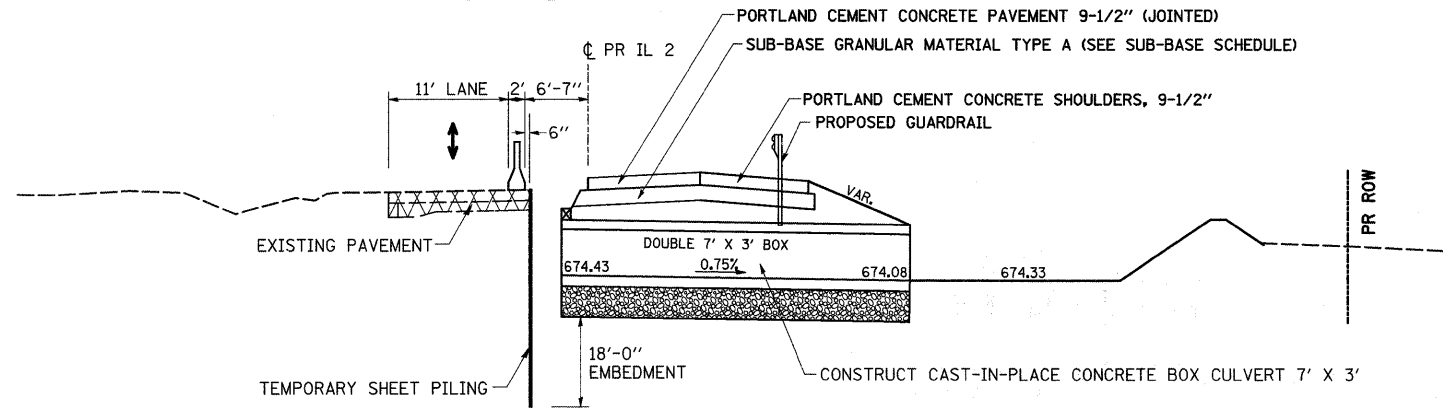

### STAGE 3

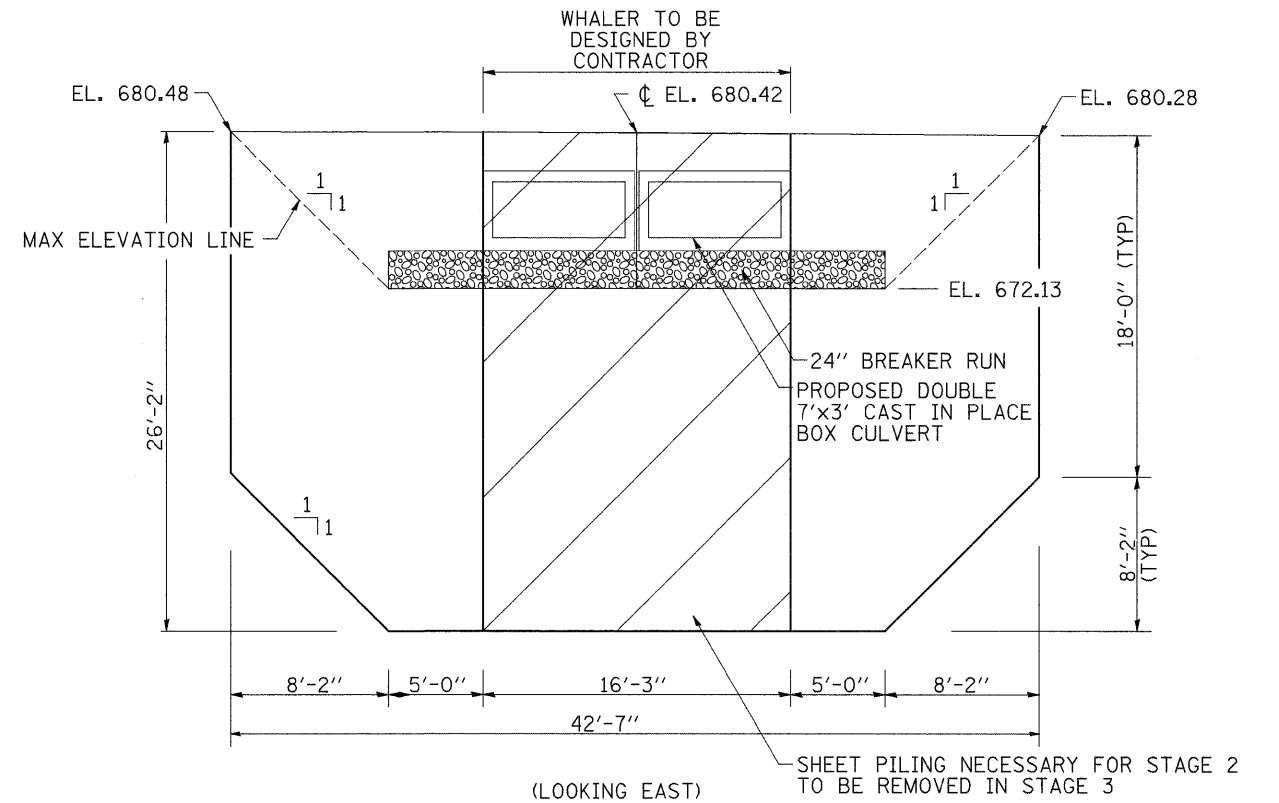
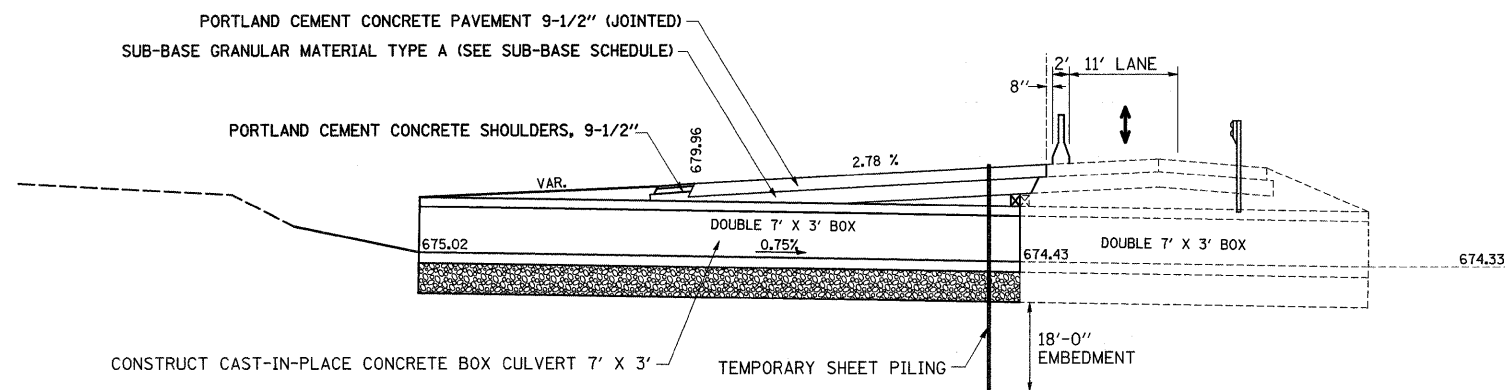

TEMPORARY SHEET PILING DATA:  
 EMBEDMENT: 18'-0" BEYOND MAX. EXCAVATION (MIN.) SECTION MODULUS: 13.65 in/ft.  
 Fy: 38,500 psi.

#### GENERAL NOTES:

- 1) TRAFFIC CONTROL TO BE SET UP AND PAID FOR ACCORDING TO TRAFFIC CONTROL AND PROTECTION STANDARD 701321.
- 2) THE CONTRACTOR IS RESPONSIBLE FOR MAINTAINING FLOW IN A MANNER ACCEPTABLE TO THE ENGINEER.
- 4) BARRIER WALL AND IMPACT ATTENUATORS SHALL BE SET UP AS SHOWN IN STANDARD 701321

FILE NAME =	USER NAME = cushmanbw	DESIGNED -	REVISED -	<b>STATE OF ILLINOIS DEPARTMENT OF TRANSPORTATION</b>	<b>STAGING CULVERT TYPICALS</b>			F.A.P. RTE. 742	SECTION 37R-3	COUNTY OGLE	TOTAL SHEETS 345	SHEET NO. 27
cs:\pw_work\PIWIDOT\CUSHMANBW\dms34123\6486typ69.dgn	PLOT SCALE = 50,0000' / IN.	DRAWN -	REVISED -					SCALE:	SHEET NO.	OF SHEETS	STA.	TO STA.
	PLOT DATE = Thu Apr 30 14:52:23 2009	CHECKED -	REVISED -									
		DATE -	REVISED -									

# STAGING CULVERT TYPICALS

## Culvert Replacement at Flagger Locations

STA. 626 + 61

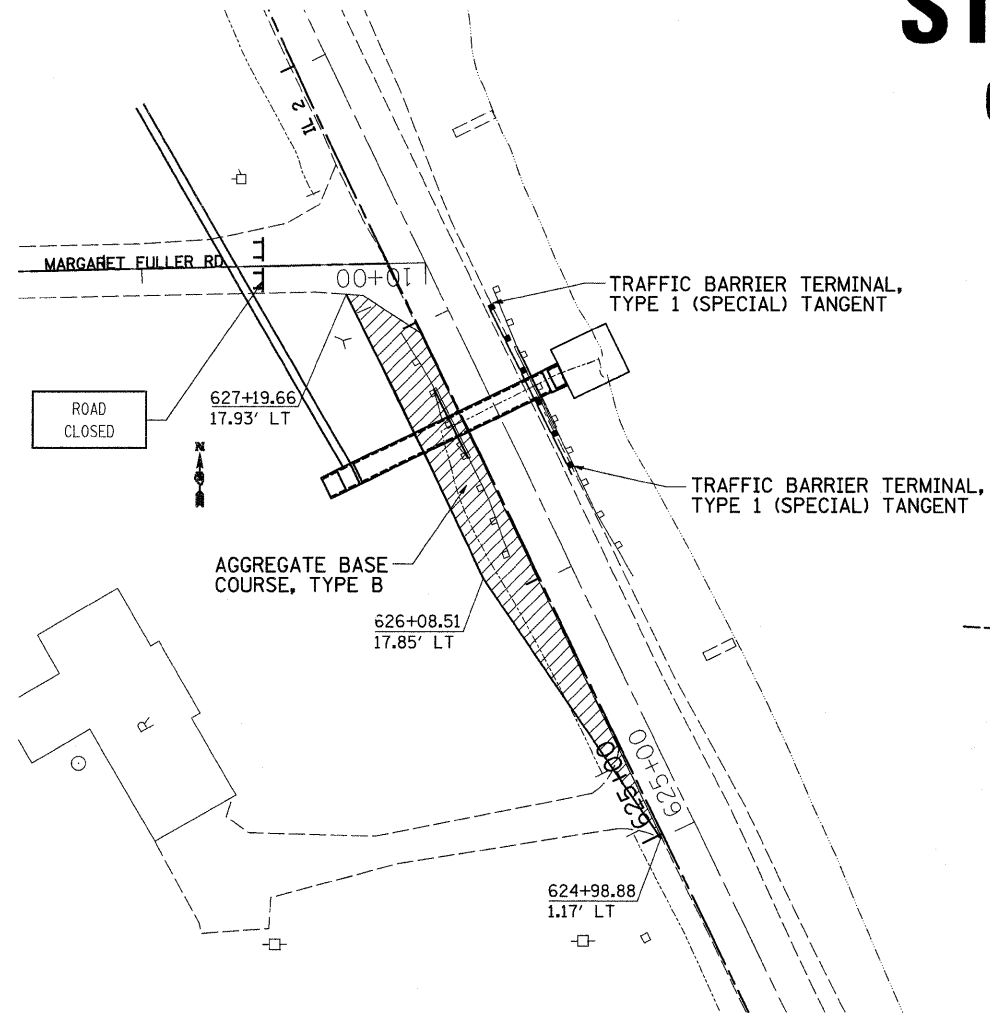

**PLAN VIEW DETAIL - STAGE 1**

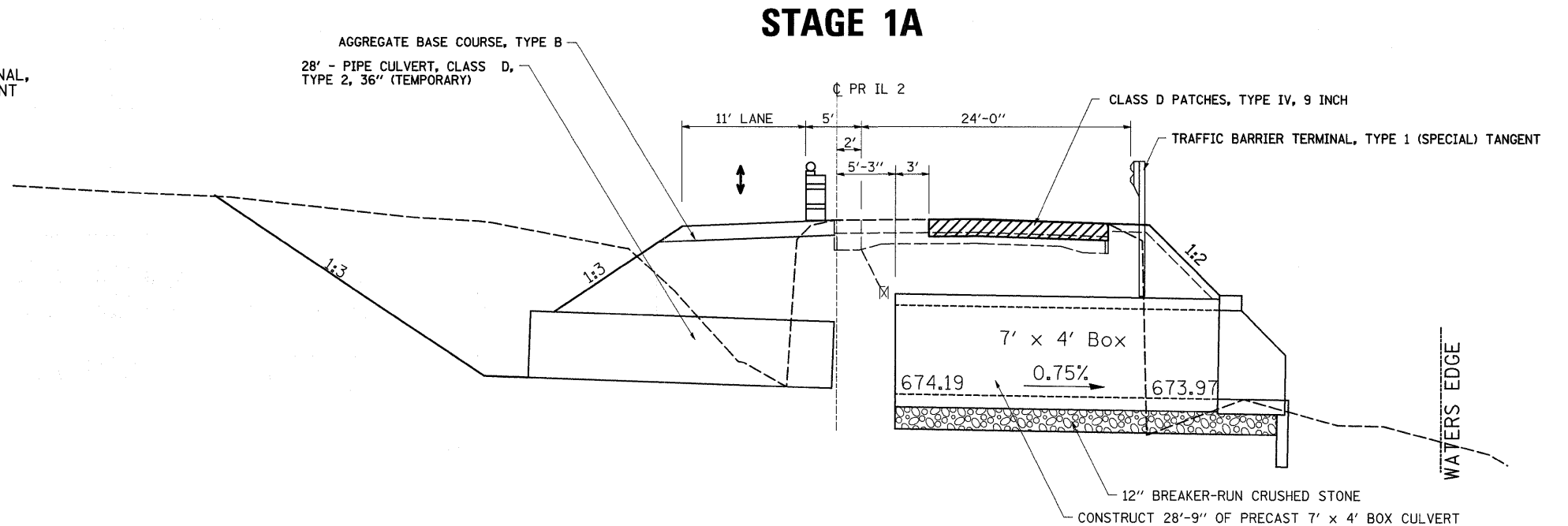

**STAGE 1B**

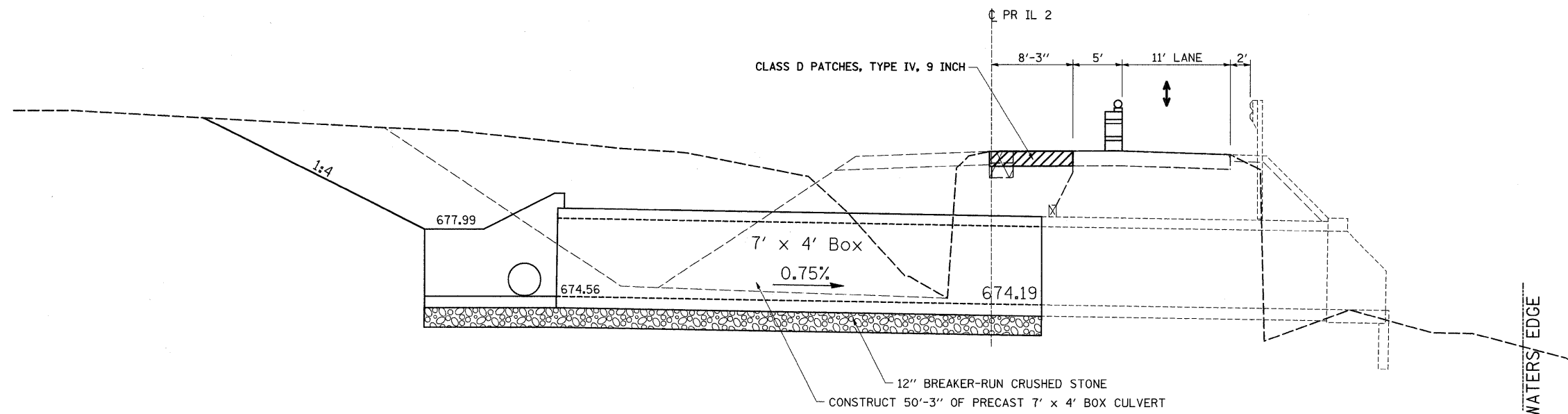

**GENERAL NOTES:**

- 1) MAINTAIN A MINIMUM OF 5 FOOT OF CLEARANCE BETWEEN STAGE LINE AND TRAFFIC.
- 2) PLACEMENT OF AGGREGATE BASE COURSE, TYPE B AS TEMPORAY RUNAROUND FOR STAGING TRAFFIC.
- 3) TRAFFIC CONTROL PROTECTION STANDARD 701201 SHALL BE USED.
- 4) CONSTRUCTION OF PRECAST 7' x 4' BOX CULVERT.
- 5) PLACEMENT OF CLASS D PATCH WHEN CULVERT IS COMPLETED.
- 6) TEMPORARY SUPPORT SYSTEM MAY BE REQUIRED PER INSPECTION.

- PAVEMENT REMOVAL
- PATCHES, TYPE IV, CLASS D, 9 INCH

FILE NAME =	USER NAME = cushmanbw	DESIGNED -	REVISED -	<b>STATE OF ILLINOIS DEPARTMENT OF TRANSPORTATION</b>	<b>STAGING CULVERT TYPICALS</b>			F.A.P. RTE.	SECTION	COUNTY	TOTAL SHEETS	SHEET NO.
ct:\pw_work\PIW\DOT\CUSHMANBW\dms34123\dms34123.dgn	6486typ69.dgn	DRAWN -	REVISED -					742	37R-3	OGLE	345	28
	PLOT SCALE = 50.0000' / IN.	CHECKED -	REVISED -					CONTRACT NO. 84788				
	PLOT DATE = Thu Apr 30 14:52:26 2009	DATE -	REVISED -					FED. ROAD DIST. NO. [ILLINOIS] FED. AID PROJECT				
				SCALE:	SHEET NO.	OF	SHEETS	STA.	TO STA.			

# STAGING CULVERT TYPICALS

## Culvert Replacement at Flagger Locations

STA. 635 + 63.70

### STAGE 1A

GENERAL NOTES:

- 1) MAINTAIN A MINIMUM OF 5 FOOT OF CLEARANCE BETWEEN STAGE LINE AND TRAFFIC.
- 2) PLACEMENT OF AGGREGATE BASE COURSE, TYPE B AS TEMPORAY RUNAROUND FOR STAGING TRAFFIC.
- 3) TRAFFIC CONTROL PROTECTION STANDARD 701201 SHALL BE USED.
- 4) CONSTRUCTION OF PRECAST 7' x 3' BOX CULVERT.
- 5) PLACEMENT OF CLASS D PATCH WHEN CULVERT IS COMPLETED.

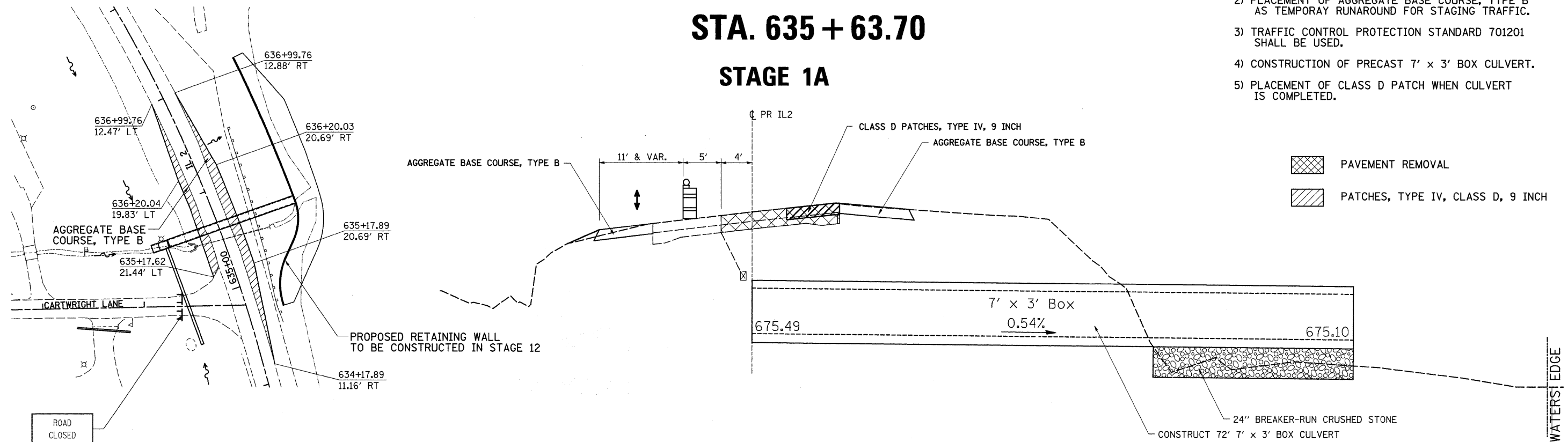

PLAN VIEW DETAIL – STAGE 1

### STAGE 1B

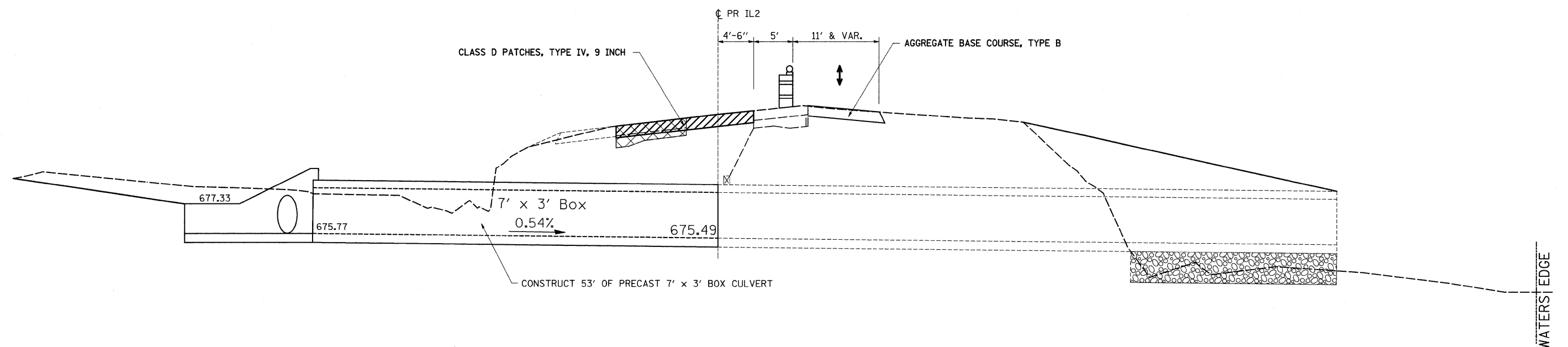

FILE NAME =	USER NAME = cushmanbw	DESIGNED -	REVISED -	<b>STATE OF ILLINOIS DEPARTMENT OF TRANSPORTATION</b>	<b>STAGING CULVERT TYPICALS</b>			F.A.P. RTE.	SECTION	COUNTY	TOTAL SHEETS	SHEET NO.
ci:\pwwork\pwwid\DOT\CUSHMANBW\dms34123\6496typ69.dgn	PLOT SCALE = 50.0000' / IN.	DRAWN -	REVISED -					742	37R-3	OGLE	345	29
	PLOT DATE = Thu Apr 30 14:52:27 2009	CHECKED -	REVISED -		SCALE: SHEET NO. OF SHEETS STA. TO STA.			CONTRACT NO. 84788				
		DATE -	REVISED -		FED. ROAD DIST. NO. ILLINOIS FED. AID PROJECT							

# SCHEDULE OF QUANTITIES

25100630 EROSION CONTROL BLANKET

20101000 TEMPORARY FENCE				REMARKS
EQDT	LOCATION			
122	LT. STA. 633 + 18	TO	634 + 40	Along Harrod property line
217	LT. STA. 666 + 64	TO	667 + 84	Along wetland boundary & construction limits within Existing R.O.W.
178	RT. STA. 37 + 37	TO	39 + 34	Cartwright Ln. - Along Harrod construction limits and temporary easement
517	TOTAL			

20101100 TREE TRUNK PROTECTION				REMARKS
EACH	LOCATION			
1	608 + 93 @ 40.1' LT			
1	611 + 0 @ 52.2' LT			
1	611 + 11 @ 52.4' LT			
1	618 + 43 @ 60.4' LT			
1	618 + 53 @ 72.6' LT			
1	637 + 97 @ 68.2' RT			
1	637 + 94 @ 65.6' RT			
1	662 + 20 @ 79.2' LT			
1	662 + 23 @ 100.7' LT			
1	662 + 30 @ 101.5' LT			
1	662 + 31 @ 77.0' LT			
1	662 + 35 @ 84.7' LT			
1	Margaret Fuller Dr. 17 + 54 @ 38.7' LT			
1	Cartwright Ln. 38 + 90 @ 57.4' RT			
1	39 + 26 @ 58.4' RT			
1	Access Rd. "A" 47 + 40 @ 18.49' RT			
1	47 + 55 @ 29.8' RT			
1	48 + 56 @ 44.7' LT			
1	Cultra Rd. 60 + 65 @ 44.3' LT			
1	60 + 65 @ 40.3' LT			
1	60 + 67 @ 47.8' LT			
1	60 + 67 @ 58.1' LT			
1	60 + 76 @ 34.3' LT			
77	Various Locations on Jobsite			Determined by the IDOT Landscape Architect
100	TOTAL			

25000775 SELECTIVE MOWING STAKES				REMARKS
EACH	LOCATION			
30	654 + 50	TO	662 + 0	
48	663 + 50	TO	675 + 50	
24	678 + 0	TO	684 + 0	
102	TOTAL			

SO_YD	LOCATION			REMARKS
2	RT. STA. 603 + 8			Concrete Headwall for Pipe Drains
2	RT. STA. 604 + 50			Concrete Headwall for Pipe Drains
2	RT. STA. 607 + 50			Concrete Headwall for Pipe Drains
2	RT. STA. 610 + 50			Concrete Headwall for Pipe Drains
2	LT. STA. 613 + 50			Concrete Headwall for Pipe Drains
772	LT. STA. 615 + 22	TO	622 + 0	Ditch ( 12'x579' )
2	LT. STA. 616 + 0			Concrete Headwall for Pipe Drains
2	LT. STA. 618 + 0			Concrete Headwall for Pipe Drains
2	LT. STA. 620 + 50			Concrete Headwall for Pipe Drains
2	LT. STA. 622 + 0			Concrete Headwall for Pipe Drains
2	RT. STA. 620 + 50			Concrete Headwall for Pipe Drains
420	LT. STA. 623 + 0	TO	626 + 61	Ditch ( 12'x315' )
373	LT. STA. 626 + 61	TO	630 + 50	Ditch ( 12'x280' )
2	RT. STA. 629 + 50			Concrete Headwall for Pipe Drains
2	RT. STA. 631 + 75			Concrete Headwall for Pipe Drains
2	RT. STA. 633 + 0			Concrete Headwall for Pipe Drains
2	LT. STA. 628 + 0			Concrete Headwall for Pipe Drains
2	LT. STA. 629 + 50			Concrete Headwall for Pipe Drains
2	LT. STA. 632 + 0			Concrete Headwall for Pipe Drains
365	LT. STA. 632 + 0	TO	635 + 64	Ditch ( 12'x274' )
2	LT. STA. 634 + 50			Concrete Headwall for Pipe Drains
1341	LT. STA. 635 + 64	TO	647 + 0	Ditch ( 12'x1006' )
2	LT. STA. 636 + 89			Concrete Headwall for Pipe Drains
2	LT. STA. 638 + 89			Concrete Headwall for Pipe Drains
2	RT. STA. 643 + 0			Concrete Headwall for Pipe Drains
2	RT. STA. 646 + 0			Concrete Headwall for Pipe Drains
2	RT. STA. 649 + 0			Concrete Headwall for Pipe Drains
2	RT. STA. 652 + 0			Concrete Headwall for Pipe Drains
2	RT. STA. 654 + 0			Concrete Headwall for Pipe Drains
2	RT. STA. 657 + 0			Concrete Headwall for Pipe Drains
2	RT. STA. 660 + 0			Concrete Headwall for Pipe Drains
2	RT. STA. 663 + 0			Concrete Headwall for Pipe Drains
2	RT. STA. 666 + 0			Concrete Headwall for Pipe Drains
2	RT. STA. 669 + 0			Concrete Headwall for Pipe Drains
2	RT. STA. 672 + 0			Concrete Headwall for Pipe Drains
2	RT. STA. 675 + 0			Concrete Headwall for Pipe Drains
2	RT. STA. 677 + 50			Concrete Headwall for Pipe Drains
496	LT. STA. 655 + 50	TO	659 + 22	Ditch ( 12'x372' )
2	LT. STA. 656 + 50			Concrete Headwall for Pipe Drains
371	LT. STA. 659 + 22	TO	662 + 0	Ditch ( 12'x278' )
2	LT. STA. 659 + 50			Concrete Headwall for Pipe Drains
2	LT. STA. 662 + 50			Concrete Headwall for Pipe Drains
280	LT. STA. 663 + 0	TO	667 + 20	Ditch ( 6'x420' )
287	LT. STA. 667 + 20	TO	671 + 50	Ditch ( 6'x430' )
49	LT. STA. 675 + 50	TO	676 + 23	Ditch ( 6'x73' )
2	LT. STA. 677 + 50			Concrete Headwall for Pipe Drains
600	LT. STA. 679 + 0	TO	683 + 50	Ditch ( 12'x450' )
2	LT. STA. 679 + 39			Concrete Headwall for Pipe Drains
256	RT. STA. 682 + 50	TO	683 + 50	Foreslope ( 23'x100' )
101	RT. STA. 48 + 74	TO	49 + 50	Access Rd. "A" Ditch ( 12'x76' )
109	LT. STA. 48 + 18	TO	49 + 0	Access Rd. "A" Ditch ( 12'x82' )
600	WINTER SHUTDOWN			
6486	TOTAL			

25100900 TURF REINFORCEMENT MAT				REMARKS
SO_YD	LOCATION			
28.0	RT. STA. 603 + 74	TO	603 + 97	Outlet of CC&G ( 12'x21' )
276.0	LT. STA. 613 + 15	TO	615 + 22	Outlet of CC&G to AR Culvert 615+22 ( 12'x207' )
52.9	LT. STA. 615 + 22			Drop Box No.1 ( 17'x28' )
64.0	LT. STA. 626 + 61			Drop Box No.2 ( 24'x24' )
60.0	LT. STA. 654 + 30			Drop Box No.4 ( 18'x30' )
50.7	LT. STA. 667 + 20			Drop Box No.5 ( 24'x19' )
249.3	RT. STA. 17 + 63	TO	19 + 50	Margaret Fuller Rd. Ditch ( 12'x187' )
249.3	LT. STA. 17 + 63	TO	19 + 50	Margaret Fuller Rd. Ditch ( 12'x187' )
266.7	RT. STA. 27 + 50	TO	29 + 50	Blackhawk Vista Ditch ( 12'x200' )
200.0	LT. STA. 27 + 50	TO	29 + 50	Blackhawk Vista Ditch ( 12'x150' )
208.0	RT. STA. 37 + 42	TO	39 + 50	Cartwright Ln. ( 12'x156' )
1704.9	TOTAL			

# SCHEDULE OF QUANTITIES

28000400 PERIMETER EROSION BARRIER

EQOT	LOCATION	REMARKS
3644	RT. STA. 603 + 8 TO 638 + 0	
651	RT. STA. 638 + 0 TO 643 + 30	
2134	RT. STA. 643 + 84 TO 661 + 95	
211	LT. STA. 647 + 0 TO 649 + 0	
207	LT. STA. 649 + 51 TO 651 + 42	
103	LT. STA. 651 + 52 TO 652 + 33	
2538	RT. STA. 662 + 27 TO 684 + 50	
200	FOR USE AT CONTRACTOR'S BORROW/WASTE/USE SITE	
900	WINTER SHUTDOWN	
10588	TOTAL	

28000500 INLET AND PIPE PROTECTION

EACH	LOCATION	REMARKS
1	LT. STA. 603 + 37	Inlet
1	LT. STA. 603 + 96	Inlet
1	LT. STA. 604 + 75	Inlet
1	LT. STA. 606 + 50	Inlet
1	LT. STA. 609 + 0	Inlet
1	LT. STA. 611 + 50	Inlet
1	LT. STA. 615 + 22	AR Culvert
1	LT. STA. 616 + 75	Entrance
1	LT. STA. 618 + 81	Entrance
1	LT. STA. 625 + 2	Entrance
1	LT. STA. 626 + 61	AR Culvert
1	LT. STA. 635 + 63	AR Culvert
1	RT. STA. 635 + 64	Inlet
1	LT. STA. 641 + 75	Entrance
1	LT. STA. 651 + 74	Entrance
1	LT. STA. 654 + 30	AR Culvert
1	LT. STA. 659 + 22	AR Culvert
2	LT. STA. 664 + 50	Open back Inlet
2	LT. STA. 666 + 0	Open back Inlet
1	LT. STA. 667 + 20	Inlet
1	LT. STA. 667 + 20	AR Culvert
2	LT. STA. 668 + 50	Open back Inlet
2	LT. STA. 670 + 0	Open back Inlet
2	LT. STA. 671 + 50	Open back Inlet
1	LT. STA. 673 + 50	Inlet
1	LT. STA. 673 + 50	Inlet
2	LT. STA. 675 + 50	Open back Inlet
2	LT. STA. 676 + 23	Open back Inlet
1	LT. STA. 678 + 70	AR Culvert
1	RT. STA. 17 + 3	Margaret Fuller Dr.
1	LT. STA. 17 + 13	Margaret Fuller Dr.
1	LT. STA. 19 + 3	AR Culvert - Margaret Fuller Dr.
1	LT. STA. 28 + 39	Blackhawk Vista
1	RT. STA. 38 + 36	Cartwright Ln.
1	RT. STA. 39 + 51	AR Culvert - Cartwright Ln.
1	RT. STA. 47 + 50	Access Road "A"
1	LT. STA. 47 + 53	Access Road "A"
1	LT. STA. 49 + 0	AR Culvert - Access Road "A"
10	Locations determined by Resident Engineer	Winter Shutdown/ Maintenance Qty.
55	TOTAL	

28100107 STONE RIPRAP, CLASS A4

SQ YD	LOCATION	REMARKS
42.0	RT. STA. 654 + 30	AR Culvert Outlet (18'x21')
47.5	RT. STA. 659 + 22	AR Culvert Outlet (19'x22.5')
45.0	RT. STA. 667 + 20	AR Culvert Outlet (15'x27')
245.9	RT. STA. 678 + 70	AR Culvert Outlet (32'x70') • Quantity duplicated on Culvert Detail Sheet
380.4	TOTAL	

28100111 STONE RIPRAP, CLASS A6

SQ YD	LOCATION	REMARKS
59.7	RT. STA. 615 + 22	AR Culvert Outlet (25'x21.5')
45.4	RT. STA. 626 + 61	AR Culvert Outlet (19'x21.5')
708.3	RT. STA. 634 + 70 TO 637 + 5	Retaining Wall (24.6'x259.6')
813.4	TOTAL	

28200200 FILTER FABRIC

SQ YD	LOCATION	REMARKS
42.0	RT. STA. 654 + 30	AR Culvert Outlet (18'x21')
47.5	RT. STA. 659 + 22	AR Culvert Outlet (19'x22.5')
45.0	RT. STA. 667 + 20	AR Culvert Outlet (15'x27')
245.9	RT. STA. 678 + 70	AR Culvert Outlet (32'x70') • Quantity duplicated on Culvert Detail Sheet
59.7	RT. STA. 615 + 22	AR Culvert Outlet (25'x21.5')
45.4	RT. STA. 626 + 61	AR Culvert Outlet (19'x21.5')
708.3	RT. STA. 634 + 70 TO 637 + 5	Retaining Wall (24.6'x259.6')
1193.8	TOTAL	

28500400 ARTICULATED BLOCK REVETMENT MAT

SQ YD	LOCATION	REMARKS
11.7	LT. STA. 613 + 0 TO 613 + 15	Outlet of CC&G to AR Culvert 615+22 (7'x15')
186.7	LT. STA. 635 + 63	Drop Box No.3 (70'x24')
198.3	TOTAL	

35101400 AGGREGATE BASE COURSE, TYPE B

TON	LOCATION	REMARKS
129	LT. STA. 626 + 61	Temp. Runaround for Staging of AR Culvert 626+61 - STAGE 1
53	LT. STA. 635 + 63	Temp. Runaround for Staging of AR Culvert 635+63 - STAGE 1
90	RT. STA. 635 + 63	Temp. Runaround for Staging of AR Culvert 635+63 - STAGE 1
8	LT/RT 654 + 30	Used to build up existing 3' aggregate shoulders (both sides) for staging
8	LT/RT 659 + 22	Used to build up existing 3' aggregate shoulders (both sides) for staging
6	LT/RT 667 + 20	Used to build up existing 3' aggregate shoulders (both sides) for staging
24	LT/RT 626 + 61 TO 667 + 20	Incidental Quantity for Temporary Patching at the Culverts
317	TOTAL	

40600300 AGGREGATE (PRIME COAT)

TON	LOCATION	REMARKS
19	LT/RT 664 + 0 TO 712 + 36	
9	LT/RT 729 + 37 TO 752 + 50	
29	TOTAL	

40600982 HOT-MIX ASPHALT SURFACE REMOVAL - BUTT JOINT

SQ YD	LOCATION	REMARKS
67	LT/RT 664 + 0 TO 664 + 25	(24'W x 25' L) STAGE 1 SMART Resurfacing
75	LT/RT 682 + 75 TO 683 + 0	(27'W x 25' L) STAGE 3 COMPLETED
67	LT/RT 712 + 11 TO 712 + 36	(24'W x 25' L) STAGE 1 SMART Resurfacing
67	LT/RT 729 + 37 TO 729 + 62	(24'W x 25' L) STAGE 1 SMART Resurfacing
67	LT/RT 752 + 25 TO 752 + 50	(24'W x 25' L) STAGE 1 SMART Resurfacing
342	TOTAL	

40600990 TEMPORARY RAMP

SQ YD	LOCATION	REMARKS
13	LT/RT 664 + 0	STAGE 1
41	LT 676 + 41	STAGE 1 Stronghold Entrance
20	LT 704 + 35	STAGE 1 CE
21	LT 705 + 81	STAGE 1 CE
13	LT/RT 712 + 36	STAGE 1
13	LT/RT 729 + 37	STAGE 1
162	RT 750 + 11	STAGE 1 MB
50	LT 750 + 69	STAGE 1 PE
13	LT/RT 752 + 50	STAGE 1
347	TOTAL	

42001300 PROTECTIVE COAT

SQ YD	LOCATION	REMARKS
1412	618 + 0 TO 628 + 29	STAGE 9 - MAINLINE
4626	628 + 29 TO 673 + 0	STAGE 10 - TEMPORARY PAVEMENT
6037	TOTAL	



# SCHEDULE OF QUANTITIES

ITEM NO.	DESCRIPTION	SQ. YD.	LOCATION	REMARKS
42001300	PROTECTIVE COAT			
		1412	618 + 0 TO	628 + 29
		4626	628 + 29 TO	673 + 0
		6037	TOTAL	
44000100	PAVEMENT REMOVAL			
		23602	LT/RT 603 + 8 TO	680 + 0
		23602	TOTAL	
			Entire Job - Including existing bituminous shoulder Shoulder Lt. Sta. 604+09 to 613+91 Shoulder Rt. Sta. 603+80 to 613+99	
44000300	CURB REMOVAL			
		67	LT. STA. 603 + 44 TO	249 + 0
		67	TOTAL	
			Around SW Radius Fair St.	
44000400	GUTTER REMOVAL			
		831	LT. STA. 604 + 10 TO	612 + 41
		831	TOTAL	
			Near Fair St.	
44000500	COMBINATION CURB AND GUTTER REMOVAL			
		49	LT. STA. 603 + 8 TO	603 + 44
		73	RT. STA. 603 + 8 TO	603 + 80
		122	TOTAL	
			Around SW Radius Fair St. Near Fair St.	
44201759	CLASS D PATCHES, TYPE IV, 9 INCH			
		94	CL 626 + 61	AR Culvert at Sta. 626+61 (done under flaggers)
		91	CL 635 + 63	AR Culvert at Sta. 635+63 (done under flaggers)
		81	CL 654 + 30	AR Culvert at Sta. 654+30 (done under flaggers)
		97	CL 659 + 22	AR Culvert at Sta. 659+22 (done under flaggers)
		62	CL 667 + 20	AR Culvert at Sta. 667+20 (done under flaggers)
		426	TOTAL	
48301000	PROTECTIVE COAT			
		905	LT/RT 618 + 0 TO	628 + 29
		905	TOTAL	
			STAGE 9 - SHOULDERS	
50100300	REMOVAL OF EXISTING STRUCTURES NO.1			
		1	LT/RT 615 + 22	4x4 Concrete Box Culvert • Quantity duplicated on Culvert Detail Sheet
		1	TOTAL	
50100400	REMOVAL OF EXISTING STRUCTURES NO.2			
		1	LT/RT 626 + 61	10x6 Concrete Box Culvert • Quantity duplicated on Culvert Detail Sheet
		1	TOTAL	

ITEM NO.	DESCRIPTION	EACH	LOCATION	REMARKS
50100500	REMOVAL OF EXISTING STRUCTURES NO.3			
		1	LT/RT 635 + 63	5x4 Concrete Box Culvert • Quantity duplicated on Culvert Detail Sheet
		1	TOTAL	
50100600	REMOVAL OF EXISTING STRUCTURES NO.4			
		1	LT/RT 654 + 30	7x2.5 Concrete Box Culvert
		1	TOTAL	
50100700	REMOVAL OF EXISTING STRUCTURES NO.5			
		1	LT/RT 659 + 22	4x2 Concrete Box Culvert • Quantity duplicated on Culvert Detail Sheet
		1	TOTAL	
50100800	REMOVAL OF EXISTING STRUCTURES NO.6			
		1	LT/RT 667 + 20	30" Round Concrete Pipe Culvert
		1	TOTAL	
50100900	REMOVAL OF EXISTING STRUCTURES NO.7			
		1	LT/RT 677 + 98	12x3 Concrete Box Culvert • Quantity duplicated on Culvert Detail Sheet
		1	TOTAL	
50101000	REMOVAL OF EXISTING STRUCTURES NO.8			
		1	LT/RT 618 + 62	24" CMP w/ Drop Structure
		1	TOTAL	
51205200	TEMPORARY SHEET PILING			
		578.4	615 + 22	AR Culvert
		268.2	677 + 98	AR Culvert - Removal of Existing
		1321.8	678 + 70	AR Culvert
		2168.4	TOTAL	
			• Quantities duplicated on Culvert Detail Sheets	
51500100	NAME PLATES			
		1	615 + 22	
		1	626 + 61	
		1	635 + 63	
		1	654 + 30	
		1	659 + 22	
		1	667 + 20	
		1	678 + 70	
		7	TOTAL	
			• Quantity duplicated on Culvert Detail Sheet	
54205305	PIPE CULVERTS, TYPE 1, CORRUGATED STEEL, EQUIVALENT ROUND SIZE 30"			
		146	LT/RT 19 + 44	Margaret Fuller Rd.
		101	LT/RT 39 + 44	Cartwright Ln.
		184	LT/RT 49 + 25	Access Road A (AR Culvert)
		431	TOTAL	

# SCHEDULE OF QUANTITIES

60108100 PIPE UNDERDRAINS 4" (SPECIAL)

54215775 METAL END SECTIONS, EQUIVALENT ROUND SIZE 30"

EACH	LOCATION	REMARKS
1	LT. STA. 19+ 44	Margaret Fuller Rd. Cartwright Ln.
1	RT. STA. 39+ 44	
2	TOTAL	

60100060 CONCRETE HEADWALL FOR PIPE DRAINS

EACH	LOCATION	REMARKS
1	RT. STA. 603+ 8	Outlet
1	RT. STA. 604+ 50	Outlet
1	RT. STA. 607+ 50	Outlet
1	RT. STA. 610+ 50	Outlet
1	RT. STA. 613+ 50	Outlet
1	LT. STA. 613+ 50	Outlet
1	LT. STA. 616+ 0	Outlet
1	LT. STA. 618+ 0	Outlet
1	LT. STA. 620+ 50	Outlet
1	LT. STA. 622+ 0	Outlet
1	RT. STA. 620+ 50	Outlet
1	RT. STA. 629+ 50	Outlet
1	RT. STA. 631+ 75	Outlet
1	RT. STA. 633+ 0	Outlet
1	LT. STA. 628+ 0	Outlet
1	LT. STA. 629+ 50	Outlet
1	LT. STA. 632+ 0	Outlet
1	LT. STA. 634+ 50	Outlet
1	LT. STA. 636+ 89	Outlet
1	LT. STA. 638+ 89	Outlet
1	RT. STA. 643+ 0	Outlet
1	RT. STA. 646+ 0	Outlet
1	RT. STA. 649+ 0	Outlet
1	RT. STA. 652+ 0	Outlet
1	RT. STA. 654+ 0	Outlet
1	RT. STA. 657+ 0	Outlet
1	RT. STA. 660+ 0	Outlet
1	RT. STA. 663+ 0	Outlet
1	RT. STA. 666+ 0	Outlet
1	RT. STA. 669+ 0	Outlet
1	RT. STA. 672+ 0	Outlet
1	RT. STA. 675+ 0	Outlet
1	RT. STA. 677+ 50	Outlet
1	LT. STA. 656+ 50	Outlet
1	LT. STA. 659+ 50	Outlet
1	LT. STA. 662+ 50	Outlet
1	LT. STA. 677+ 50	Outlet
1	LT. STA. 679+ 39	Outlet
38	TOTAL	

60107600 PIPE UNDERDRAINS 4"

FOOT	LOCATION	REMARKS
1042	RT. STA. 603+ 8 TO 613+ 50	Inlet Connection - Dist. Std. (88.4)
1150	LT. STA. 611+ 0 TO 622+ 50	
24	LT. STA. 603+ 30	Inlet Connection - Dist. Std. (88.4)
24	LT. STA. 607+ 77	
250	RT. STA. 620+ 0 TO 622+ 50	Inlet Connection - Dist. Std. (88.4)
611	RT. STA. 626+ 89 TO 633+ 0	
789	LT. STA. 628+ 0 TO 635+ 89	Inlet Connection - Dist. Std. (88.4)
400	LT. STA. 636+ 89 TO 640+ 89	
3450	RT. STA. 643+ 0 TO 677+ 50	Inlet Connection - Dist. Std. (88.4)
2289	LT. STA. 656+ 50 TO 679+ 39	
37	LT. STA. 664+ 50	Inlet Connection - Dist. Std. (88.4)
37	LT. STA. 668+ 57	
37	LT. STA. 671+ 0	
37	LT. STA. 673+ 57	
10177	TOTAL	

FOOT	LOCATION	REMARKS
22	RT. STA. 603+ 8	Outlet
33	RT. STA. 604+ 50	Outlet
25	RT. STA. 607+ 50	Outlet
16	RT. STA. 610+ 50	Outlet
14	RT. STA. 613+ 50	Outlet
18	LT. STA. 613+ 50	Outlet
17	LT. STA. 616+ 0	Outlet
17	LT. STA. 618+ 0	Outlet
20	LT. STA. 620+ 50	Outlet
18	LT. STA. 622+ 0	Outlet
27	RT. STA. 620+ 0	Outlet
43	RT. STA. 629+ 50	Outlet
38	RT. STA. 631+ 75	Outlet
18	RT. STA. 633+ 0	Outlet
18	LT. STA. 628+ 0	Outlet
16	LT. STA. 629+ 50	Outlet
15	LT. STA. 632+ 0	Outlet
18	LT. STA. 634+ 50	Outlet
15	LT. STA. 636+ 89	Outlet
20	LT. STA. 638+ 89	Outlet
14	RT. STA. 643+ 0	Outlet
20	RT. STA. 646+ 0	Outlet
20	RT. STA. 649+ 0	Outlet
20	RT. STA. 652+ 0	Outlet
20	RT. STA. 654+ 0	Outlet
15	RT. STA. 657+ 0	Outlet
15	RT. STA. 660+ 0	Outlet
18	RT. STA. 663+ 0	Outlet
18	RT. STA. 666+ 0	Outlet
18	RT. STA. 669+ 0	Outlet
18	RT. STA. 672+ 0	Outlet
15	RT. STA. 675+ 0	Outlet
24	RT. STA. 677+ 50	Outlet
24	LT. STA. 656+ 50	Outlet
15	LT. STA. 659+ 50	Outlet
18	LT. STA. 662+ 50	Outlet
15	LT. STA. 677+ 50	Outlet
18	LT. STA. 679+ 39	Outlet
753	TOTAL	

60255500 MANHOLES TO BE ADJUSTED

EACH	LOCATION	REMARKS
1	LT. STA. 603+ 60	ø 44.6' LT.
1	RT. STA. 603+ 42	ø 19.3' RT
2	TOTAL	Fair St. Near Fair St.

60406100 FRAMES AND LIDS, TYPE 1, CLOSED LID

EACH	LOCATION	REMARKS
1	To be determined by the RE	Estimated Quantity
1	TOTAL	

60500040 REMOVING MANHOLES

EACH	LOCATION	REMARKS
1	LT. STA. 603+ 40	ø 14.8' LT
1	RT. STA. 603+ 41	ø 24.1' RT.
2	TOTAL	Near Fair St. Across from Fair St.

60500060 REMOVING INLETS

EACH	LOCATION	REMARKS
1	603+ 65	ø 15.4' RT
1	603+ 37	ø 17.4' LT
2	TOTAL	Across from Fair St. SW Radius of Fair St.

# SCHEDULE OF QUANTITIES

CUBIC YARD	LOCATION	REMARKS
3.11	RT. STA. 603 + 50 TO 603 + 87	Across from Fair St. - see plan sheet, build with ExROW Outlet - extend per standard for 3% slope Inlet
4.42	LT. STA. 612 + 50 TO 613 + 0	
1.23	LT. STA. 663 + 0 TO 663 + 12	
8.76	TOTAL	

EQUOT	LOCATION	REMARKS
260.0	RT. STA. 634 + 70 TO 637 + 5	Along Retaining Wall, Special (Overlook No. 1) Along Retaining Wall, Special (Near Stronghold's Entrance) * Quantities duplicated on Retaining Wall Detail Sheets
173.2	LT. STA. 673 + 50 TO 675 + 22	
433.2	TOTAL	

EQUOT	LOCATION	REMARKS
110	LT. STA. 603 + 8 TO 249 + 41	SW Radius of Fair St. Across from Fair St. along IL 2 NW Radius of Fair St. Along IL 2 (North) of Fair St.
42	RT. STA. 603 + 8 TO 603 + 50	
75	LT. STA. 249 + 0 TO 604 + 13	
837	LT. STA. 604 + 13 TO 612 + 50	
1064	TOTAL	

EQUOT	LOCATION	REMARKS
1292	LT. STA. 663 + 12 TO 676 + 4	Along IL2 SW Radius at Stronghold Entrance
175	LT. STA. 676 + 4 TO 68 + 0	
1467	TOTAL	

EQUOT	LOCATION	REMARKS
1037.5	RT. STA. 604 + 50 TO 614 + 87.5	Fair St. - Along IL 2 Along IL 2 Along IL 2 Around Overlook No.1 Around N. Radius of Future Boat Ramp Along IL 2 Along IL 2
1075	RT. STA. 615 + 56.25 TO 626 + 31.25	
312.5	RT. STA. 626 + 93.75 TO 630 + 6.25	
725	RT. STA. 630 + 6.25 TO 637 + 8	
100	RT. STA. 676 + 59 TO 677 + 17.1	
125	RT. STA. 677 + 17.1 TO 678 + 42.10	
75	RT. STA. 679 + 23.35 TO 679 + 98.35	
3450	TOTAL	

EQUOT	LOCATION	REMARKS
25	RT. STA. 614 + 87.5 TO 615 + 12.5	
25	RT. STA. 615 + 31.25 TO 615 + 56.25	
25	RT. STA. 626 + 31.25 TO 626 + 56.25	
25	RT. STA. 626 + 68.75 TO 626 + 93.75	
31.25	RT. STA. 678 + 42.10 TO 678 + 73.35	
25	RT. STA. 678 + 98.35 TO 679 + 23.35	
156.25	TOTAL	

EQUOT	LOCATION	REMARKS
18.75	RT. STA. 615 + 12.5 TO 615 + 31.25	Case IV Case IV Case IV
12.5	RT. STA. 626 + 56.25 TO 626 + 68.75	
25	RT. STA. 678 + 73.35 TO 678 + 98.35	
56.25	TOTAL	

EACH	LOCATION	REMARKS
1	RT. STA. 637 + 8	Overlook Area No.1 Future Boat Ramp Entrance
1	LT. STA. 70 + 84	
2	TOTAL	

EACH	LOCATION	REMARKS
1	RT. STA. 604 + 0 TO 604 + 50	Stage 1 for Construction of AR Culvert at 626+61 Stage 1 for Construction of AR Culvert at 626+61
1	RT. STA. 626 + 11 TO 626 + 61	
1	RT. STA. 626 + 61 TO 627 + 11	
3	TOTAL	

EQUOT	LOCATION	REMARKS
100	LT. STA. 614 + 71 TO 615 + 72	AR Culvert AR Culvert AR Culvert AR Culvert AR Culvert AR Culvert AR Culvert AR Culvert AR Culvert AR Culvert
100	RT. STA. 614 + 71 TO 615 + 72	
87.5	LT. STA. 626 + 12 TO 626 + 98	
112.5	RT. STA. 625 + 86 TO 627 + 0	
200	RT. STA. 634 + 55 TO 636 + 49	
75	LT. STA. 654 + 9 TO 654 + 82	
125	RT. STA. 653 + 62 TO 654 + 87	
125	LT. STA. 677 + 34 TO 678 + 58	
150	RT. STA. 677 + 19 TO 678 + 70	
225	RT. STA. 680 + 84 TO 683 + 4.6	
1300	TOTAL	

EACH	LOCATION	REMARKS
1	RT. STA. 626 + 11 TO 626 + 61	Stage 1 for Construction of AR Culvert at 626+61 Stage 1 for Construction of AR Culvert at 626+61
1	RT. STA. 626 + 61 TO 627 + 11	
2	TOTAL	

EACH	LOCATION	REMARKS
2	LT/RT 615 + 22	AR Culvert AR Culvert AR Culvert AR Culvert AR Culvert AR Culvert AR Culvert At Ends of Type 1 (Special) Tangent - STAGE 1 At End of Type 1 (Special) Tangent At End of Type 2 (Overlook No. 1) At End of Type 2 (Future Boat Ramp Entr.)
2	LT/RT 626 + 61	
2	LT/RT 635 + 64	
2	LT/RT 654 + 30	
2	LT/RT 659 + 22	
2	LT/RT 667 + 20	
2	LT/RT 678 + 70	
2	RT. STA. 626 + 61	
1	RT. STA. 604 + 0	
1	RT. STA. 637 + 27	
1	LT. STA. 70 + 84	
19	TOTAL	

EQUOT	LOCATION	REMARKS	
1300	RT. STA. 644 + 0 TO 657 + 0		
900	RT. STA. 663 + 0 TO 672 + 0		
289	RT. STA. 677 + 11 TO 680 + 0		
150	LT. STA. 647 + 50 TO 649 + 0		
165	LT. STA. 649 + 50 TO 651 + 15		
63	LT. STA. 651 + 56 TO 652 + 19		
62	LT. STA. 653 + 3 TO 653 + 65		
62	LT. STA. 654 + 19 TO 654 + 81		
735	LT. STA. 655 + 16 TO 662 + 51		
1293	LT. STA. 662 + 91 TO 675 + 84		
280	LT. STA. 677 + 20 TO 680 + 0		
5299	TOTAL		

EQUOT	LOCATION	REMARKS
232	LT. STA. 615 + 74 TO 618 + 6	Between Drives to Cemetery Markers North of Entrance 618+44 (PE)
30	LT. STA. 618 + 40	
38	LT. STA. 618 + 86	
300	TOTAL	

EACH	LOCATION	REMARKS
1	610 + 69.06 @ 44' LT.	
1	611 + 0.00 @ 40' LT.	
1	612 + 50.00 @ 40' LT.	
1	613 + 0.00 @ 60' LT.	
1	613 + 50.00 @ 50' LT.	
1	614 + 50.00 @ 50' LT.	
1	614 + 95.00 @ 65' LT.	
1	615 + 50.00 @ 65' LT.	
1	616 + 0.00 @ 50' LT.	
1	617 + 0.00 @ 55' LT.	
1	619 + 0.00 @ 60' LT.	
1	623 + 0.00 @ 65' LT.	
1	625 + 90.03 @ 31.71' RT.	
1	626 + 35.90 @ 53.88' RT.	
1	627 + 0.00 @ 67.99' LT.	
1	628 + 25.00 @ 70' LT.	
1	630 + 75.00 @ 70' LT.	
1	632 + 0.00 @ 85' LT.	
1	633 + 0.00 @ 90' LT.	
1	633 + 18.43 @ 88.16' LT.	
1	633 + 13.78 @ 69.93' LT.	
1	634 + 31.68 @ 70' LT.	
1	635 + 70.00 @ 100' LT.	
1	636 + 0.00 @ 85' LT.	
1	636 + 95.00 @ 90' LT.	
1	637 + 47.00 @ 75' LT.	
1	638 + 47.00 @ 75' LT.	
1	639 + 94.00 @ 75' LT.	
1	641 + 25.00 @ 75' LT.	
1	642 + 19.34 @ 59.98' RT.	
1	642 + 35.60 @ 89.88' LT.	
1	643 + 3.20 @ 59.86' RT.	
1	643 + 75.00 @ 96.92' LT.	
1	654 + 5.00 @ 51.93' RT.	
1	654 + 15.00 @ 44.09' LT.	
1	654 + 15.00 @ 70' LT.	
1	654 + 20.00 @ 70' RT.	
1	654 + 40.00 @ 70' RT.	
1	654 + 50.00 @ 51.64' RT.	
1	654 + 85.47 @ 68.58' LT.	
1	658 + 50.00 @ 51.32' RT.	
1	658 + 75.00 @ 71.73' LT.	
1	659 + 0.00 @ 85' LT.	
1	659 + 0.00 @ 75' RT.	
1	659 + 50.00 @ 75' RT.	
1	659 + 50.00 @ 85' LT.	
1	659 + 75.00 @ 73.58' LT.	
1	660 + 0.00 @ 60' RT.	
1	661 + 50.00 @ 60' RT.	
1	663 + 0.00 @ 50.46' RT.	
1	666 + 75.00 @ 49.74' RT.	
1	667 + 0.00 @ 65' RT.	
1	667 + 50.00 @ 65' RT.	
1	667 + 75.00 @ 49.55' RT.	
1	672 + 0.00 @ 48.83' RT.	
1	673 + 0.00 @ 85' RT.	
1	675 + 50.00 @ 58.68' LT.	
1	676 + 0.00 @ 75' LT.	
1	677 + 0.00 @ 85' LT.	
1	677 + 75.00 @ 105' LT.	
1	678 + 0.00 @ 85' RT.	
1	678 + 50.00 @ 105' LT.	
1	678 + 99.00 @ 90' RT.	
1	679 + 0.00 @ 75' LT.	
1	680 + 0.00 @ 80' LT.	
1	681 + 0.00 @ 52.93' LT.	
1	681 + 0.00 @ 85' RT.	
1	682 + 65.20 @ 85' RT.	
<b>SIDERROADS</b>		
1	18 + 75.00 @ 29.08' RT.	Margaret Fuller Rd.
1	18 + 75.00 @ 30.92' LT.	Margaret Fuller Rd.
1	28 + 90.00 @ 30.32' RT.	Blackhawk Vista
1	28 + 0.00 @ 29.71' LT.	Blackhawk Vista
1	38 + 85.00 @ 29.52' RT.	Cartwright Lane
1	38 + 60.00 @ 30.42' LT.	Cartwright Lane
1	48 + 10.44 @ 35.91' LT.	Access Rd. "A"
1	51 + 0.00 @ 25' LT.	Access Rd. "B"
1	51 + 0.00 @ 25' RT.	Access Rd. "B"
1	51 + 50.00 @ 25' LT.	Access Rd. "B"
1	51 + 50.00 @ 25' RT.	Access Rd. "B"
1	51 + 82.19 @ 24.45' RT.	Access Rd. "B"
1	52 + 0.00 @ 25' LT.	Access Rd. "B"
1	60 + 75.00 @ 30.47' LT.	Cultra Rd.
1	60 + 75.00 @ 35.54' RT.	Cultra Rd.

83 TOTAL

# SCHEDULE OF QUANTITIES

66700305 PERMANENT SURVEY MARKERS, TYPE II

EACH	LOCATION	REMARKS
2	LT/RT 615 + 22	AR Culvert - Location determined by District office - Chief of Surveys
2	LT/RT 626 + 63	AR Culvert - Location determined by District office - Chief of Surveys
2	LT/RT 635 + 52	AR Culvert - Location determined by District office - Chief of Surveys
2	LT/RT 654 + 26	AR Culvert - Location determined by District office - Chief of Surveys
2	LT/RT 659 + 22	AR Culvert - Location determined by District office - Chief of Surveys
2	LT/RT 667 + 20	AR Culvert - Location determined by District office - Chief of Surveys
2	LT/RT 678 + 70	AR Culvert - Location determined by District office - Chief of Surveys
14	TOTAL	

70106500 TEMPORARY BRIDGE TRAFFIC SIGNALS

EACH	LOCATION	REMARKS
1	RT/ LT 670 + 94 & 684 + 5	Stage #2 for Sta. 673+00 to 680+00
1	RT/ LT 600 + 54 & 613 + 93	Stage #4 for Sta. 603+08 to 611+00
1	RT/ LT 608 + 42 & 620 + 68	Stage #6 for Sta. 611+00 to 618+00
3	TOTAL	

70106700 TEMPORARY RUMBLE STRIP

EACH	LOCATION	REMARKS
1	RT. STA. 653 + 94	AR Culvert at Sta. 678+70 (Stage 2)
1	RT. STA. 658 + 94	AR Culvert at Sta. 678+70 (Stage 2)
1	RT. STA. 663 + 94	AR Culvert at Sta. 678+70 (Stage 2)
1	LT. STA. 691 + 5	AR Culvert at Sta. 678+70 (Stage 2)
1	LT. STA. 696 + 5	AR Culvert at Sta. 678+70 (Stage 2)
1	LT. STA. 701 + 5	AR Culvert at Sta. 678+70 (Stage 2)
1	RT. STA. 652 + 6	AR Culvert at Sta. 678+70 (Stage 3)
1	RT. STA. 657 + 6	AR Culvert at Sta. 678+70 (Stage 3)
1	RT. STA. 662 + 6	AR Culvert at Sta. 678+70 (Stage 3)
1	LT. STA. 689 + 79	AR Culvert at Sta. 678+70 (Stage 3)
1	LT. STA. 694 + 79	AR Culvert at Sta. 678+70 (Stage 3)
1	LT. STA. 699 + 79	AR Culvert at Sta. 678+70 (Stage 3)
12	TOTAL	

70300100 SHORT-TERM PAVEMENT MARKING

EQUT	LOCATION	REMARKS
<u>Stage 1 (Sta. 664+00 - 752+50)</u>		
440	CL 664 + 0 TO 712 + 36	Centerline Skips - After Stage 1 complete
212	CL 729 + 37 TO 752 + 50	Centerline Skips - After Stage 1 complete
<u>Stage 3 (Sta. 673+00 - 680+00)</u>		
128	CL 669 + 6 TO 682 + 79	Centerline Skips - After Stage 3 complete
55	LT 669 + 6 TO 682 + 79	Edge Line (45 degrees) - After Stage 3 complete
55	RT 669 + 6 TO 682 + 79	Edge Line (45 degrees) - After Stage 3 complete
<u>Stage 5 (Sta. 603+08 - 611+00)</u>		
124	CL 600 + 54 TO 613 + 93	Centerline Skips - After Stage 5 complete
54	LT 600 + 54 TO 613 + 93	Edge Line (45 degrees) - After Stage 5 complete
54	RT 600 + 54 TO 613 + 93	Edge Line (45 degrees) - After Stage 5 complete
<u>Stage 7 (Sta. 611+00 - 618+00)</u>		
120	CL 608 + 13 TO 621 + 6	Centerline Skips - After Stage 7 complete
52	LT 608 + 13 TO 621 + 6	Edge Line (45 degrees) - After Stage 7 complete
52	RT 608 + 13 TO 621 + 6	Edge Line (45 degrees) - After Stage 7 complete
<u>Stage 9 (Sta. 618+00 - 628+29)</u>		
164	CL 614 + 0 TO 632 + 0	Centerline Skips - After Stage 9 complete
72	LT 614 + 0 TO 632 + 0	Edge Line (45 degrees) - After Stage 9 complete
72	RT 614 + 0 TO 632 + 0	Edge Line (45 degrees) - After Stage 9 complete
<u>Stage 12 (Sta. 628+29 - 673+00)</u>		
484	CL 620 + 1 TO 673 + 25	Centerline Skips - After Stage 12 complete
213	LT 620 + 1 TO 673 + 25	Edge Line (45 degrees) - After Stage 12 complete
213	RT 620 + 1 TO 673 + 25	Edge Line (45 degrees) - After Stage 12 complete
2562	TOTAL	

EQOT	LOCATION	REMARKS
Stage 2 (Sta. 673+00 - 680+00)		
306	LT. STA. 670+ 94 TO 674+ 0	Edge Line (LT)
550	LT. STA. 674+ 0 TO 679+ 50	Edge Line (LT)
450	LT. STA. 679+ 50 TO 684+ 5	Edge Line (LT)
307	RT. STA. 670+ 94 TO 674+ 0	Edge Line (RT)
550	RT. STA. 674+ 0 TO 679+ 50	Edge Line (RT)
458	RT. STA. 679+ 50 TO 684+ 6	Edge Line (RT)
252	CL 682+ 79 TO 684+ 5	Centerline - Dbl. Yellow
Stage 3 (Sta. 673+00 - 680+00)		
498	LT. STA. 669+ 6 TO 674+ 0	Edge Line (LT)
203	LT. STA. 674+ 0 TO 676+ 2	Edge Line (LT)
266	LT. STA. 676+ 85 TO 679+ 50	Edge Line (LT)
332	LT. STA. 679+ 50 TO 682+ 79	Edge Line (LT)
497	RT. STA. 669+ 6 TO 674+ 0	Edge Line (RT)
552	RT. STA. 674+ 0 TO 679+ 50	Edge Line (RT)
333	RT. STA. 679+ 50 TO 682+ 79	Edge Line (RT)
1394	LT. STA. 669+ 6 TO 683+ 0	Edge Line - After Stage 3 complete
1394	RT. STA. 669+ 6 TO 683+ 0	Edge Line - After Stage 3 complete
1189	CL 677+ 5 TO 683+ 0	Centerline - Dbl. Yellow -- After Stage 3 complete
216	RT. STA. 673+ 0 TO 676+ 70	Diagonals at 45 degrees - White
1378	LT. STA. 669+ 57 TO 673+ 0	Median for Taper Area -- After Stage 3 complete
114	LT. STA. 669+ 57 TO 673+ 0	Diagonals at 45 degrees - Double Yellow
524	LT. STA. 673+ 21 TO 675+ 83	Turn Bay Line (Stronghold)
524	RT. STA. 673+ 21 TO 675+ 83	Turn Bay Line (Boat Ramp)
560	LT. STA. 677+ 5 TO 679+ 85	Turn Bay Line (Stronghold)
77	LT. STA. 679+ 85 TO 681+ 38	Turkey Tracks (Stronghold)
560	LT. STA. 677+ 5 TO 679+ 85	Turn Bay Line (Boat Ramp)
120	LT. STA. 679+ 85 TO 682+ 24	Turkey Tracks (Boat Ramp)
Stage 4 (Sta. 603+00 - 611+00)		
449	LT. STA. 600+ 54 TO 605+ 0	Edge Line (LT)
553	LT. STA. 605+ 0 TO 610+ 50	Edge Line (LT)
345	LT. STA. 610+ 50 TO 613+ 93	Edge Line (LT)
449	RT. STA. 600+ 54 TO 605+ 0	Edge Line (RT)
553	RT. STA. 605+ 0 TO 610+ 50	Edge Line (RT)
345	RT. STA. 610+ 50 TO 613+ 93	Edge Line (RT)
Stage 5 (Sta. 603+00 - 611+00)		
449	LT. STA. 600+ 54 TO 605+ 0	Edge Line (LT)
550	LT. STA. 605+ 0 TO 610+ 50	Edge Line (LT)
345	LT. STA. 610+ 50 TO 613+ 93	Edge Line (LT)
449	RT. STA. 600+ 54 TO 605+ 0	Edge Line (RT)
550	RT. STA. 605+ 0 TO 610+ 50	Edge Line (RT)
344	RT. STA. 610+ 50 TO 613+ 93	Edge Line (RT)
Stage 6 (Sta. 611+00 - 618+00)		
411	LT. STA. 608+ 42 TO 612+ 50	Edge Line (LT)
554	LT. STA. 612+ 50 TO 618+ 0	Edge Line (LT)
270	LT. STA. 618+ 0 TO 620+ 68	Edge Line (LT)
407	RT. STA. 608+ 42 TO 612+ 50	Edge Line (RT)
555	RT. STA. 612+ 50 TO 618+ 0	Edge Line (RT)
270	RT. STA. 618+ 0 TO 620+ 68	Edge Line (RT)
Stage 7 (Sta. 611+00 - 618+00)		
439	LT. STA. 608+ 13 TO 612+ 50	Edge Line (LT)
550	LT. STA. 612+ 50 TO 618+ 0	Edge Line (LT)
308	LT. STA. 618+ 0 TO 621+ 6	Edge Line (LT)
435	RT. STA. 608+ 15 TO 612+ 50	Edge Line (RT)
550	RT. STA. 612+ 50 TO 618+ 0	Edge Line (RT)
310	RT. STA. 618+ 0 TO 621+ 6	Edge Line (RT)
Stage 8 (Sta. 618+00 - 628+20)		
400	LT. STA. 614+ 0 TO 618+ 0	Edge Line (LT)
551	LT. STA. 618+ 0 TO 623+ 50	Edge Line (LT)
551	LT. STA. 623+ 50 TO 629+ 0	Edge Line (LT)
448	LT. STA. 629+ 0 TO 633+ 44	Edge Line (LT)
802	CL 614+ 0 TO 618+ 0	Centerline - Dbl. Yellow
1102	CL 618+ 0 TO 623+ 50	Centerline - Dbl. Yellow
1100	CL 623+ 50 TO 629+ 0	Centerline - Dbl. Yellow
890	CL 629+ 0 TO 633+ 44	Centerline - Dbl. Yellow
402	RT. STA. 614+ 0 TO 618+ 0	Edge Line (RT)
552	RT. STA. 618+ 0 TO 623+ 50	Edge Line (RT)
550	RT. STA. 623+ 50 TO 629+ 0	Edge Line (RT)
444	RT. STA. 629+ 0 TO 633+ 44	Edge Line (RT)
36	CL 632+ 0 TO 633+ 44	Centerline (Skips) -- After Stage 8 complete
144	LT. STA. 632+ 0 TO 633+ 44	Edge Line - After Stage 8 complete
144	RT. STA. 632+ 0 TO 633+ 44	Edge Line - After Stage 8 complete
Stage 9 (Sta. 618+00 - 628+20)		
398	LT. STA. 614+ 0 TO 618+ 0	Edge Line (LT)
550	LT. STA. 618+ 0 TO 623+ 50	Edge Line (LT)
552	LT. STA. 623+ 50 TO 629+ 0	Edge Line (LT)
303	LT. STA. 629+ 0 TO 632+ 0	Edge Line (LT)
798	CL 614+ 0 TO 618+ 0	Centerline - Dbl. Yellow
1100	CL 618+ 0 TO 623+ 50	Centerline - Dbl. Yellow
1102	CL 623+ 50 TO 629+ 0	Centerline - Dbl. Yellow
602	CL 629+ 0 TO 632+ 0	Centerline - Dbl. Yellow
400	RT. STA. 614+ 0 TO 618+ 0	Edge Line (RT)
551	RT. STA. 618+ 0 TO 623+ 50	Edge Line (RT)
552	RT. STA. 623+ 50 TO 629+ 0	Edge Line (RT)
300	RT. STA. 629+ 0 TO 632+ 0	Edge Line (RT)

# SCHEDULE OF QUANTITIES

EQOT	LOCATION	REMARKS
Stage 11 (Sta. 628+20 - 673+00)		
63	LT. STA. 620+ 1 TO 624+ 50	Diagonals at 45 degrees - White
76	LT. STA. 624+ 50 TO 626+ 77	Diagonals at 45 degrees - White
448	LT. STA. 620+ 1 TO 624+ 50	Edge Line (LT)
5140	LT. STA. 624+ 50 TO 673+ 50	Edge Line (LT)
501	LT. STA. 673+ 50 TO 678+ 50	Edge Line (LT)
900	CL 620+ 0 TO 624+ 50	Centerline - Dbl. Yellow
9758	CL 624+ 50 TO 673+ 25	Centerline - Dbl. Yellow
1824	CL 673+ 25 TO 678+ 50	Centerline - Dbl. Yellow
354	CL 673+ 50 TO 679+ 0	Diagonals at 45 degrees - Double Yellow
476	CL 679+ 85 TO 682+ 24	Centerline - Dbl. Yellow
260	CL 679+ 0 TO 683+ 0	Diagonals at 45 degrees - Double Yellow
450	RT. STA. 620+ 0 TO 624+ 50	Edge Line (RT)
4900	RT. STA. 624+ 50 TO 673+ 50	Edge Line (RT)
361	RT. STA. 673+ 50 TO 677+ 11	Edge Line (RT)
43	CL 620+ 1 TO 621+ 72	Centerline (Skips) - After Stage 11 complete
170	LT. STA. 620+ 1 TO 621+ 72	Edge Line - After Stage 11 complete
170	RT. STA. 620+ 1 TO 621+ 72	Edge Line - After Stage 11 complete
Stage 12 (Sta. 628+20 - 673+00)		
279	LT. STA. 621+ 72 TO 624+ 50	Edge Line (LT)
4917	LT. STA. 624+ 50 TO 673+ 50	Edge Line (LT)
361	LT. STA. 673+ 50 TO 677+ 11	Edge Line (LT)
558	CL 621+ 72 TO 624+ 50	Centerline - Dbl. Yellow
9774	CL 624+ 50 TO 673+ 25	Centerline - Dbl. Yellow
2040	CL 673+ 25 TO 679+ 58	Centerline - Dbl. Yellow
279	RT. STA. 621+ 72 TO 624+ 50	Edge Line (RT)
4909	RT. STA. 624+ 50 TO 673+ 50	Edge Line (RT)
609	RT. STA. 673+ 50 TO 679+ 58	Edge Line (RT)

88987 TOTAL

70300660 TEMPORARY PAINT PAVEMENT MARKING LINE 24"

EQOT	LOCATION	REMARKS
Stage 2 (Sta. 673+00 - 680+00)		
13	RT. STA. 670+ 94	Stop Bar
20	LT. STA. 676+ 21	Stop Bar at Stronghold Entrance
13	LT. STA. 684+ 5	Stop Bar
Stage 3 (Sta. 673+00 - 680+00)		
13	RT. STA. 669+ 6	Stop Bar
12	LT. STA. 676+ 35	Stop Bar at Stronghold Entrance
13	LT. STA. 682+ 79	Stop Bar
Stage 4 (Sta. 603+00 - 611+00)		
13	RT. STA. 600+ 54	Stop Bar
13	LT. STA. 613+ 93	Stop Bar
Stage 5 (Sta. 603+00 - 611+00)		
13	RT. STA. 613+ 21	Stop Bar
Stage 6 (Sta. 611+00 - 618+00)		
13	RT. STA. 608+ 42	Stop Bar
13	LT. STA. 620+ 68	Stop Bar
Stage 7 (Sta. 611+00 - 618+00)		
12	RT. STA. 608+ 15	Stop Bar
13	LT. STA. 621+ 6	Stop Bar

174 TOTAL

70301000 WORKZONE PAVEMENT MARKING REMOVAL

EQOT	LOCATION	REMARKS
Stage 2 (Sta. 673+00 - 680+00)		
69.0	LT. STA. 670+ 94 TO 673+ 0	Edge Line (LT)
133.7	LT. STA. 680+ 0 TO 684+ 5	Edge Line (LT)
69.3	RT. STA. 670+ 94 TO 673+ 0	Edge Line (RT)
136.0	RT. STA. 680+ 0 TO 684+ 6	Edge Line (RT)
26.0	RT. STA. 670+ 94	Stop Bar
26.0	LT. STA. 684+ 5	Stop Bar
Stage 3 (Sta. 673+00 - 680+00)		
166.0	LT. STA. 669+ 6 TO 674+ 0	Edge Line (LT)
67.5	LT. STA. 674+ 0 TO 676+ 2	Edge Line (LT)
88.7	LT. STA. 676+ 85 TO 679+ 50	Edge Line (LT)
110.7	LT. STA. 679+ 50 TO 682+ 79	Edge Line (LT)
26.7	RT. STA. 673+ 21 TO 674+ 0	Edge Line (RT)
184.0	RT. STA. 674+ 0 TO 679+ 50	Edge Line (RT)
111.0	RT. STA. 679+ 50 TO 682+ 79	Edge Line (RT)
26.0	RT. STA. 669+ 6	Stop Bar
24.0	LT. STA. 676+ 35	Stop Bar at Stronghold Entrance
26.0	LT. STA. 682+ 79	Stop Bar
42.7	CL 669+ 6 TO 682+ 79	Centerline Skips - After Stage 3 complete
18.3	LT 669+ 6 TO 682+ 79	Edge Line (45 degrees) - After Stage 3 complete
18.3	RT 669+ 6 TO 682+ 79	Edge Line (45 degrees) - After Stage 3 complete
Stage 4 (Sta. 603+00 - 611+00)		
85.7	LT. STA. 600+ 54 TO 603+ 8	Edge Line (LT)
98.3	LT. STA. 611+ 0 TO 613+ 93	Edge Line (LT)
85.3	RT. STA. 600+ 54 TO 603+ 8	Edge Line (RT)
98.3	RT. STA. 611+ 0 TO 613+ 93	Edge Line (RT)

# SCHEDULE OF QUANTITIES

Stage 5 (Sta. 603+08 - 611+00)				
149.7	LT. STA.	600 + 54	TO 605 + 0	Edge Line (LT)
183.3	LT. STA.	605 + 0	TO 610 + 50	Edge Line (LT)
115.0	LT. STA.	610 + 50	TO 613 + 93	Edge Line (LT)
149.7	RT. STA.	600 + 54	TO 605 + 0	Edge Line (RT)
183.3	RT. STA.	605 + 0	TO 610 + 50	Edge Line (RT)
114.7	RT. STA.	610 + 50	TO 613 + 93	Edge Line (RT)
26.0	RT. STA.	600 + 54		Stop Bar
26.0	LT. STA.	613 + 93		Stop Bar
26.0	LT. STA.	613 + 21		Stop Bar
41.3	CL	600 + 54	TO 613 + 93	Centerline Skips - After Stage 5 complete
17.9	LT	600 + 54	TO 613 + 93	Edge Line (45 degrees) - After Stage 5 complete
17.9	RT	600 + 54	TO 613 + 93	Edge Line (45 degrees) - After Stage 5 complete
Stage 6 (Sta. 611+00 - 618+00)				
87.0	LT. STA.	608 + 42	TO 611 + 0	Edge Line (LT)
90.0	LT. STA.	618 + 0	TO 620 + 68	Edge Line (LT)
86.0	RT. STA.	608 + 42	TO 611 + 0	Edge Line (RT)
90.0	RT. STA.	618 + 0	TO 620 + 68	Edge Line (RT)
26.0	RT. STA.	608 + 42		Stop Bar
26.0	LT. STA.	620 + 68		Stop Bar
Stage 7 (Sta. 611+00 - 618+00)				
146.3	LT. STA.	608 + 13	TO 612 + 50	Edge Line (LT)
183.3	LT. STA.	612 + 50	TO 618 + 0	Edge Line (LT)
102.7	LT. STA.	618 + 0	TO 621 + 6	Edge Line (LT)
145.0	RT. STA.	608 + 15	TO 612 + 50	Edge Line (RT)
183.3	RT. STA.	612 + 50	TO 618 + 0	Edge Line (RT)
103.3	RT. STA.	618 + 0	TO 621 + 6	Edge Line (RT)
24.0	RT. STA.	608 + 15		Stop Bar
26.0	LT. STA.	621 + 6		Stop Bar
40.0	CL	608 + 13	TO 621 + 6	Centerline Skips - After Stage 7 complete
17.2	LT	608 + 13	TO 621 + 6	Edge Line (45 degrees) - After Stage 7 complete
17.2	RT	608 + 13	TO 621 + 6	Edge Line (45 degrees) - After Stage 7 complete
Stage 8 (Sta. 618+00 - 628+29)				
133.3	LT. STA.	614 + 0	TO 618 + 0	Edge Line (LT)
173.3	LT. STA.	628 + 29	TO 633 + 44	Edge Line (LT)
267.3	CL	614 + 0	TO 618 + 0	Centerline - Dbl. Yellow
172.3	CL	628 + 29	TO 633 + 44	Centerline - Dbl. Yellow
134.0	RT. STA.	614 + 0	TO 618 + 0	Edge Line (RT)
171.7	RT. STA.	628 + 29	TO 633 + 44	Edge Line (RT)
Stage 9 (Sta. 618+00 - 628+29)				
132.7	LT. STA.	614 + 0	TO 618 + 0	Edge Line (LT)
183.3	LT. STA.	618 + 0	TO 623 + 50	Edge Line (LT)
184.0	LT. STA.	623 + 50	TO 629 + 0	Edge Line (LT)
101.0	LT. STA.	629 + 0	TO 632 + 0	Edge Line (LT)
266.0	CL	614 + 0	TO 618 + 0	Centerline - Dbl. Yellow
366.7	CL	618 + 0	TO 623 + 50	Centerline - Dbl. Yellow
367.3	CL	623 + 50	TO 629 + 0	Centerline - Dbl. Yellow
200.7	CL	629 + 0	TO 632 + 0	Centerline - Dbl. Yellow
133.3	RT. STA.	614 + 0	TO 618 + 0	Edge Line (RT)
183.7	RT. STA.	618 + 0	TO 623 + 50	Edge Line (RT)
184.0	RT. STA.	623 + 50	TO 629 + 0	Edge Line (RT)
100.0	RT. STA.	629 + 0	TO 632 + 0	Edge Line (RT)
54.7	CL	614 + 0	TO 632 + 0	Centerline Skips - After Stage 9 complete
24.0	LT	614 + 0	TO 632 + 0	Edge Line (45 degrees) - After Stage 9 complete
24.0	RT	614 + 0	TO 632 + 0	Edge Line (45 degrees) - After Stage 9 complete
12.0	CL	632 + 0	TO 633 + 44	Centerline (Skips) - After Stage 8 complete
47.9	LT. STA.	632 + 0	TO 633 + 44	Edge Line - After Stage 8 complete
47.9	RT. STA.	632 + 0	TO 633 + 44	Edge Line - After Stage 8 complete
Stage 11 (Sta. 628+29 - 673+00)				
21.0	LT. STA.	620 + 1	TO 624 + 50	Diagonals at 45 degrees - White
25.3	LT. STA.	624 + 50	TO 626 + 77	Diagonals at 45 degrees - White
352.3	LT. STA.	620 + 1	TO 628 + 29	Edge Line (LT)
184.0	LT. STA.	673 + 0	TO 678 + 50	Edge Line (LT)
552.7	CL	620 + 0	TO 628 + 29	Centerline - Dbl. Yellow
624.7	CL	673 + 0	TO 678 + 50	Centerline - Dbl. Yellow
276.0	RT. STA.	620 + 0	TO 628 + 29	Edge Line (RT)
137.0	RT. STA.	673 + 0	TO 677 + 11	Edge Line (RT)
72.0	RT. STA.	673 + 0	TO 676 + 70	Diagonals at 45 degrees - White
459.3	LT. STA.	669 + 6	TO 671 + 29	Median for Taper Area -- After Stage 3 complete
38.0	LT. STA.	669 + 57	TO 673 + 18	Diagonals at 45 degrees - Double Yellow
174.8	LT. STA.	673 + 21	TO 675 + 83	Turn Bay Line (Stronghold)
174.8	RT. STA.	673 + 21	TO 675 + 83	Turn Bay Line (Boat Ramp)
39.8	LT. STA.	679 + 85	TO 682 + 24	Turkey Tracks (Boat Ramp)

Stage 12 (Sta. 628+29 - 673+00)				
93.0	LT. STA.	621 + 72	TO 624 + 50	Edge Line (LT)
1639.0	LT. STA.	624 + 50	TO 673 + 50	Edge Line (LT)
120.3	LT. STA.	673 + 50	TO 677 + 11	Edge Line (LT)
186.0	CL	621 + 72	TO 624 + 50	Centerline - Dbl. Yellow
3258.0	CL	624 + 50	TO 673 + 25	Centerline - Dbl. Yellow
680.0	CL	673 + 25	TO 679 + 58	Centerline - Dbl. Yellow
93.0	RT. STA.	621 + 72	TO 624 + 50	Edge Line (RT)
1636.3	RT. STA.	624 + 50	TO 673 + 50	Edge Line (RT)
203.0	RT. STA.	673 + 50	TO 679 + 58	Edge Line (RT)
14.2	CL	620 + 1	TO 621 + 72	Centerline (Skips) - After Stage 11 complete
56.8	LT. STA.	620 + 1	TO 621 + 72	Edge Line - After Stage 11 complete
56.8	RT. STA.	620 + 1	TO 621 + 72	Edge Line - After Stage 11 complete
161.3	CL	620 + 1	TO 673 + 25	Centerline Skips - After Stage 12 complete
71.0	LT	620 + 1	TO 673 + 25	Edge Line (45 degrees) - After Stage 12 complete
71.0	RT	620 + 1	TO 673 + 25	Edge Line (45 degrees) - After Stage 12 complete
118.0	CL	673 + 50	TO 679 + 0	Diagonals at 45 degrees - Double Yellow
158.7	CL	679 + 85	TO 682 + 24	Centerline - Dbl. Yellow
86.7	CL	679 + 0	TO 683 + 0	Diagonals at 45 degrees - Double Yellow

19681.5	TOTAL			
70400100	TEMPORARY CONCRETE BARRIER			
	<b>EQOIT</b>	<b>LOCATION</b>		<b>REMARKS</b>
		Stage 2 (Sta. 673+00 - 680+00)		
25	LT	672 + 50	TO 672 + 75	Taper Section - Stage 2 at AR Culvert 678+70
750	LT	672 + 75	TO 680 + 26	Tangent Section - Stage 2 at AR Culvert 678+70
162.5	LT/RT	680 + 26	TO 681 + 88	Taper - Stage 2 at AR Culvert 678+70 (North)
937.5	TOTAL			
70400200	RELOCATE TEMPORARY CONCRETE BARRIER			
	<b>EQOIT</b>	<b>LOCATION</b>		<b>REMARKS</b>
		Stage 3 (Sta. 673+00 - 680+00)		
175	LT/RT	671 + 0	TO 672 + 75	Taper Section - Stage 3 at AR Culvert 678+70 (South)
287.5	RT	672 + 75	TO 675 + 63	Tangent Section - Stage 3 at AR Culvert 678+70
300	RT	677 + 25	TO 680 + 25	Tangent Section - Stage 3 at AR Culvert 678+70
75	RT/LT	680 + 25	TO 680 + 99	Taper - Stage 3 at AR Culvert 678+70 (North)
		Stage 6 (Sta. 611+00 - 618+00)		
50	LT	614 + 20	TO 614 + 70	Taper Section - Stage 6 at AR Culvert 615+22 (South)
100	LT	614 + 70	TO 615 + 70	Tangent Section - Stage 6 at AR Culvert 615+22
50	LT	615 + 70	TO 616 + 20	Taper - Stage 6 at AR Culvert 615+22 (North)
		Stage 7 (Sta. 611+00 - 618+00)		
200	LT	614 + 20	TO 616 + 20	Tangent Section - Stage 7 at AR Culvert 615+22
1237.5	TOTAL			
70500100	TEMPORARY STEEL PLATE BEAM GUARDRAIL, TYPE A			
	<b>EQOIT</b>	<b>LOCATION</b>		<b>REMARKS</b>
312.5	RT. STA.	679 + 98.4	TO 683 + 4.6	
312.5	TOTAL			
78200410	GUARDRAIL MARKERS, TYPE A			
	<b>EACH</b>	<b>LOCATION</b>		<b>REMARKS</b>
6	RT. STA.	604 + 50	TO 608 + 50	80' spacing
7	RT. STA.	608 + 50	TO 620 + 75	175' spacing
2	RT. STA.	620 + 75	TO 628 + 75	400' spacing
3	RT. STA.	628 + 75	TO 633 + 25	150' spacing
3	RT. STA.	633 + 25	TO 637 + 0	125' spacing
5	RT. STA.	70 + 84	TO 677 + 11	20' spacing (Future Boat ramp)
5	RT. STA.	677 + 11	TO 681 + 11	80' spacing
3	RT. STA.	681 + 11	TO 684 + 86	125' spacing
34	TOTAL			
78201000	TERMINAL MARKER - DIRECT APPLIED			
	<b>EACH</b>	<b>LOCATION</b>		<b>REMARKS</b>
1	RT. STA.	604 + 0		End of Type 1 (Special) Tangent - STAGE 4
1	RT. STA.	626 + 11		End of Type 1 (Special) Tangent - STAGE 1
1	RT. STA.	627 + 11		End of Type 1 (Special) Tangent - STAGE 1
1	RT. STA.	637 + 29		End of Type 2 (Overlook No. 1)
1	LT. STA.	70 + 84		End of Type 2 (Future Boat Ramp Entr.)
5	TOTAL			

# SCHEDULE OF QUANTITIES

SO. FT	LOCATION	REMARKS
Stage 2 (Sta. 673+00 - 680+00)		
437.2	LT. STA. 670 + 94 TO 684 + 6	Edge Line
109.3	CL 670 + 94 TO 684 + 6	Skips
338.2	CL 670 + 94 TO 681 + 9	No passing Line
198.1	CL 681 + 9 TO 684 + 6	Centerline Dbl. Yellow
68.6	RT. STA. 670 + 94 TO 673 + 0	Edge Line
135.3	RT. STA. 680 + 0 TO 684 + 6	Edge Line
Stage 3 (Sta. 673+00 - 680+00)		
15.7	CL 669 + 6 TO 670 + 94	Skips
62.7	CL 669 + 6 TO 670 + 94	No passing Line
62.7	RT. STA. 669 + 6 TO 670 + 94	Edge Line
Stage 4 (Sta. 603+08 - 611+00)		
92.8	LT. STA. 600 + 54 TO 603 + 32	Edge Line
327.8	LT. STA. 604 + 10 TO 613 + 93	Edge Line
42.4	CL 600 + 54 TO 603 + 8	Centerline Dbl. Yellow
48.9	CL 611 + 0 TO 613 + 93	Centerline Dbl. Yellow
Stage 5 (Sta. 603+08 - 611+00)		
84.8	RT. STA. 600 + 54 TO 603 + 8	Edge Line
97.8	RT. STA. 611 + 0 TO 613 + 93	Edge Line
Stage 6 (Sta. 611+00 - 618+00)		
135.6	RT. STA. 613 + 93 TO 618 + 0	Edge Line
89.2	RT. STA. 618 + 0 TO 620 + 68	Edge Line
56.0	CL 613 + 93 TO 615 + 61	No passing Line
33.9	CL 613 + 93 TO 618 + 0	Skips
22.3	CL 618 + 0 TO 620 + 68	Skips
Stage 7 (Sta. 611+00 - 618+00)		
102.2	LT. STA. 618 + 0 TO 621 + 6	Edge Line
3.2	CL 620 + 68 TO 621 + 6	Skips
13.0	RT. STA. 620 + 68 TO 621 + 6	Edge Line
Stage 8 (Sta. 618+00 - 628+29)		
412.4	LT. STA. 621 + 6 TO 633 + 44	Edge Line
106.3	CL 620 + 68 TO 633 + 44	Skips
412.4	RT. STA. 621 + 6 TO 633 + 44	Edge Line
Stage 11 (Sta. 628+29 - 673+00)		
485.4	LT. STA. 633 + 44 TO 648 + 0	Edge Line
329.7	CL 633 + 44 TO 673 + 0	Skips
100.3	CL 669 + 99 TO 673 + 0	No passing Line
1318.8	RT. STA. 633 + 44 TO 673 + 0	Edge Line
5743.0	TOTAL	

Z0030250 IMPACT ATTENUATORS, TEMPORARY (NON-REDIRECTIVE), TEST LEVEL 3

EACH	LOCATION	REMARKS
1	RT. STA. 680 + 0	Stage #1 (Sta. 603+08 to 683+00)
1	RT. STA. 681 + 88	Stage #2 (Sta. 673+00 to 680+00)
1	RT. STA. 675 + 63	Stage #3 (Sta. 673+00 to 680+00) --- Narrow Setup
1	RT. STA. 677 + 25	Stage #3 (Sta. 673+00 to 680+00) --- Narrow Setup
1	LT. STA. 614 + 20	Stage #7 (Sta. 611+00 to 618+00) --- Narrow Setup
5	TOTAL	

Z0030350 IMPACT ATTENUATORS, RELOCATE (NON-REDIRECTIVE), TEST LEVEL 3

EACH	LOCATION	REMARKS
1	LT. STA. 672 + 50	Stage #2 (Sta. 673+00 to 680+00)
1	LT. STA. 671 + 0	Stage #3 (Sta. 673+00 to 680+00)
1	LT. STA. 680 + 99	Stage #3 (Sta. 673+00 to 680+00)
1	RT. STA. 608 + 50	Stage #4 (Sta. 603+08 TO 611+00) --- Narrow Setup
1	RT. STA. 614 + 20	Stage #6 (Sta. 611+00 to 618+00)
1	RT. STA. 616 + 20	Stage #6 (Sta. 611+00 to 618+00)
1	RT. STA. 615 + 50	Stage #7 (Sta. 611+00 to 618+00) --- Narrow Setup
1	LT. STA. 616 + 20	Stage #7 (Sta. 611+00 to 618+00) --- Narrow Setup
1	RT. STA. 627 + 0	Stage #9 (Sta. 618+00 to 628+29) --- Narrow Setup
9	TOTAL	

Z0073400 TEMPORARY SUPPORT SYSTEM

EACH	LOCATION	REMARKS
1	LT. STA. 626 + 61	Stage #1 (If needed per Inspection)
1	LT. STA. 677 + 98	Stage #2 for Sta. 678+03
2	TOTAL	

X0321461 PILLAR REMOVAL

EACH	LOCATION	REMARKS
1	LT. STA. 618 + 71 @ 22' LT	Pillar at Property Corner
1	LT. STA. 622 + 40 @ 23' LT	Pillar at PE with light
1	LT. STA. 622 + 63 @ 23' LT	Pillar at PE with light
1	LT. STA. 624 + 69 @ 21' LT	Pillar at Property Corner
4	TOTAL	

X0325519 DRAIN FOR AGGREGATE BASE COURSE

SO. YD	LOCATION	REMARKS
0.67	LT. STA. 626 + 89	See District Std. (96.4)
2.33	RT. STA. 626 + 89	See District Std. (96.4)
0.67	LT. STA. 635 + 89	See District Std. (96.4)
1.00	LT. STA. 640 + 89	See District Std. (96.4)
0.67	LT. STA. 642 + 25	See District Std. (96.4)
3.33	LT. STA. 680 + 0	See District Std. (96.4)
0.06	LT. STA. 18 + 76	Margaret Fuller Rd.
0.06	RT. STA. 18 + 76	Margaret Fuller Rd.
0.06	LT. STA. 28 + 92	Blackhawk Vista
0.06	RT. STA. 28 + 92	Blackhawk Vista
0.06	LT. STA. 38 + 87	Cartwright Ln.
0.06	RT. STA. 38 + 87	Cartwright Ln.
9.05	TOTAL	

X0325666 CORRUGATED STEEL PIPE MULTIPLE END SECTIONS, EQUIVALENT, DOUBLE, ROUND SIZE 30"

EACH	LOCATION	REMARKS
2	LT/RT 49 + 25	Access Rd. A (AR culvert)
2	TOTAL	

FLAGSTONE WALL REMOVAL

EQOT	LOCATION	REMARKS
23	LT. STA. 654 + 17 @ 52' LT	The Silo
23	TOTAL	

STONE PILLARS TO BE RELOCATED

EACH	LOCATION	REMARKS
1	LT. STA. 618 + 45	Cemetery Entrance (Concrete & Block) Pillars at PE
1	LT. STA. 618 + 63	Cemetery Entrance (Concrete & Block) Pillars at PE
2	TOTAL	

TIMBER RETAINING WALL MODIFICATION

EQOT	LOCATION	REMARKS
13	LT. STA. 611 + 91 @ 20.9' LT	Along South side of Private Entrance 612+05 LT
13	TOTAL	

REMOVE EXISTING MONUMENT

EACH	LOCATION	REMARKS
1	LT. STA. 618 + 95 @ 19' LT	Honor Monument for Ogle County Soldiers & Sailors
1	TOTAL	

# EARTHWORK /SEEDING SCHEDULE

LOCATION	20200100	20400800				25200110	25000100	25000210	25000310	25000400	25000500	25000600	25000750	25100115	25200200	28000250	21101615
	EARTH EXC (CUT)	FURNISHED EXC	EARTH EXC ADJ SHRINK 25% EARTH	EMBANK (FILL)	EARTH WORK BALANCE WASTE (+) SHORTAGE (-)	SODDING SALT TOLERANT	SEEDING CLASS 1	SEEDING CLASS 2A	SEEDING CLASS 4	NITROGEN FERTILIZER NUTRIENTS	PHOSPHOROUS FERTILIZER NUTRIENTS	POTASSIUM FERTILIZER NUTRIENTS	MOWING	MULCH METHOD 2	SUPPLEMENTAL WATERING	TEMPORARY EROSION CONTROL SEEDING	TOPSOIL FURNISH & PLACE 4"
	CU YD	CU YD	CU YD	CU YD	CU YD	SQ YD	ACRE	ACRE	ACRE	POUND	POUND	POUND	ACRE	ACRE	UNIT	POUNDS	SQ YD
603+7.85 - 616+ 50	2629		1972	141	1831	1920		0.18		40.18	40.18	40.18	0.58	0.18	17.28	867.97	2801
616+50 - 630+ 50	8348		6261	81	6180	4293		0.57		104.48	104.48	104.48	1.46	0.57	38.64	2184.81	7050
630+50 - 644+ 50	8123		6093	1725	4368	3954	0.02	0.55		100.82	100.82	100.82	1.39	0.58	35.58	2088.77	6740
644+50 - 658+ 50	3071		2303	1947	356		0.02	0.86	0.07	86.14	86.14	86.14	0.96	0.96		1435.64	4632
658+50 - 672+ 50	3713		2785	1193	1592		0.04	0.77	0.21	91.70	91.70	91.70	1.02	1.02		1528.41	4932
672+50 - 680+00	1893	3882	1419	3831	-2411		0.04	0.71	0.14	80.11	80.11	80.11	0.89	0.89		1335.16	4308
680+00 - 684+ 50	796		597	1235	-638			0.23	0.09	28.96	28.96	28.96	0.32	0.32		482.75	1558
<b>SIDEROADS</b>																	
<b>FAIR ST</b>																	
249+00 - 249+ 75	202		151	2	150	147				1.83	1.83	1.83	0.03		1.33	45.70	147
<b>MARGARET FULLER</b>																	
16+75 - 19+ 50	1282		962	3	959	1077				13.36	13.36	13.36	0.22		9.70	333.92	1077
<b>BLACKHAWK VISTA</b>																	
27+50 - 29+ 50	1011		758	0	758	888				11.01	11.01	11.01	0.18		8.00	275.31	888
<b>CARTWRIGHT LANE</b>																	
37+25 - 39+ 50	1554		1165	2	1163	1105				13.70	13.70	13.70	0.23		9.95	342.49	1105
<b>ACCESS RD. "A"</b>																	
47+50 - 49+ 75	780		585	4	581	559				6.93	6.93	6.93	0.12		5.03	173.31	559
<b>ACCESS RD. "B"</b>																	
50+50 - 52+ 25	190		142	171	-28	587				7.27	7.27	7.27	0.12		5.28	181.82	587
<b>CULTRA RD.</b>																	
60+50 - 60+ 80	84		63	0	63					0.00	0.00	0.00	0.00			0.00	0
<b>STRONGHOLD ENTRANCE</b>																	
68+00 - 69+ 50	348		261	3	258		0.04	0.03		6.22	6.22	6.22	0.07	0.07		103.65	334
<b>FUTURE BOAT RAMP</b>																	
70+50 - 70+ 84	0		0	401	-401			0.03		2.29	2.29	2.29	0.03	0.03		38.09	123
<b>WINTER SHUTDOWN</b>																	
													7.61			1100.00	
<b>TOTAL</b>	<b>34023</b>	<b>3882</b>	<b>25517</b>	<b>10737</b>	<b>14780</b>	<b>14531</b>	<b>0.16</b>	<b>3.93</b>	<b>0.52</b>	<b>595</b>	<b>595</b>	<b>595</b>	<b>15.22</b>	<b>4.61</b>	<b>130.78</b>	<b>12518</b>	<b>36841</b>



# PAVING SCHEDULE

Location	Remarks	Length	Proposed Surface		40600200	40800050	42000411	48300410	X0712400	X0919000
			Width	Sq Yd	Bituminous Materials Prime Coat	Incidental Hot-Mix Asphalt Surfacing	Portland Cement Conc. Pavement 9 1/2" (Jointed)	Portland Cement Conc. Shoulders, 9 1/2"	Temporary Pavement	Temporary Pavement Removal
					Ton	Ton	Sq Yd	Sq Yd	Sq. Yd.	Sq. Yd.
<b>IL 2 - MAIN LINE *</b>										
Lt & Rt Sta 603 + 8 - 604 + 40	Main Line	132	VAR	797			797.00			
Lt & Rt Sta 604 + 40 - 620 + 12	Main Line, Station Equation 620+11.65	1571	24	4191			4190.51			
Lt & Rt Sta 620 + 12 - 620 + 42	Main Line, Station Equation 620+12.36	30	VAR	82			82.24			
Lt & Rt Sta 620 + 42 - 626 + 57	Main Line	615	VAR	2223			2222.78			
Lt & Rt Sta 626 + 57 - 630 + 58	Main Line	401	VAR	2549			2548.78			
Lt & Rt Sta 630 + 58 - 634 + 23	Main Line	365	VAR	2534			2534.00			
Lt & Rt Sta 634 + 23 - 638 + 74	Main Line	450	VAR	2850			2850.40			
Rt Sta	Overlook No.1	-	VAR	978	1.4	191.7				
Lt & Rt Sta 638 + 74 - 648 + 56	Main Line	983	VAR	6219			6219.00			
Lt & Rt Sta 648 + 56 - 656 + 36	Main Line	780	38	3310			3310.00			
Lt & Rt Sta 656 + 36 - 662 + 83	Main Line	646	VAR	3661			3660.89			
Lt & Rt Sta 662 + 83 - 670 + 71	Main Line	788	38	3326			3326.44			
Lt & Rt Sta 670 + 71 - 679 + 83	Main Line	912	VAR	5570			5570.09			
Lt & Rt Sta 679 + 83 - 680 + 0	Main Line	17	VAR	96			96.22			
Lt & Rt Sta 680 + 0 - 683 + 0	Main Line - Transition to Existing	300	VAR	1379	2.0	115.8				
<b>SIDE ROAD'S</b>										
Margaret Fuller Rd. 16 + 75 - 18 + 76		201.08	VAR	421	0.6	82.6				
Blackhawk Vista 27 + 50 - 28 + 92		141.51	VAR	304	0.4	59.5				
Cartwright Ln. 37 + 25 - 38 + 87		162.07	VAR	340	0.5	66.6				
Access Rd. A 47 + 50 - 48 + 30		80	VAR	167			167.2			
Access Rd. B 50 + 93 - 52 + 3		109.58	VAR	476	0.7	93.2				
Stronghold Entrance 67 + 97 - 68 + 95		98.811	VAR	256	0.4	50.2				
<b>Right Side Shoulders</b>										
Rt. Sta 603 + 64 - 604 + 0	Transition	35.78	VAR	29			29.1			
Rt. Sta 604 + 0 - 607 + 80		379.96	8	338			337.7			
Rt. Sta 607 + 80 - 615 + 0	Behind Guardrail	720.04	8	640			640.0			
Rt. Sta 615 + 0 - 630 + 0	Behind Guardrail	1500	8	1333			1333.3			
Rt. Sta 630 + 0 - 632 + 32		231.73	8	206			206.0			
Rt. Sta 632 + 32 - 637 + 17	Behind Guardrail/ Overlook No.1	511	8	454			454.2			
Rt. Sta 634 + 73 - 638 + 15	In front of Overlook No. 1	378	8	336			336.0			
Rt. Sta 637 + 17 - 637 + 89	Around PE at Rt. Sta. 637+93	72.2	VAR	37			37.1			
Rt. Sta 637 + 93 - 637 + 94	Radius at PE at Rt. Sta. 637+93	0.78	VAR	37			37.2			
Rt. Sta 637 + 94 - 638 + 15	Transition	21.55	VAR	16			16.2			
Rt. Sta 638 + 15 - 638 + 69		54	8	48			48.0			
Rt. Sta 638 + 69 - 639 + 43	Transition	73.68	VAR	55			55.1			
Rt. Sta 639 + 43 - 643 + 37	Rt. Turn and Ent. Radius	345	4	221			220.6			
Rt. Sta 643 + 85 - 643 + 74	Ent. Radius/ Transition	305	VAR	146			146.0			
Rt. Sta 643 + 74 - 656 + 36		1262.3	8	1122			1122.0			
Rt. Sta 656 + 36 - 657 + 39	Transition	102.26	VAR	76			75.6			
Rt. Sta 657 + 39 - 661 + 36	Rt. Turn to Cultra Rd.	398.25	4	177			177.0			
Rt. Sta 661 + 36 - 661 + 99	S. Radius of Cultra Rd.	93.3	4	41			41.5			
Rt. Sta 662 + 33 - 662 + 86	N. Radius of Cultra Rd. w/ Transition	53.07	VAR	52			52.4			
Rt. Sta 662 + 86 - 670 + 71		784.72	8	698			697.5			
Rt. Sta 670 + 71 - 671 + 77	Transition	106.77	VAR	79			79.0			
Rt. Sta 671 + 77 - 676 + 31	Rt. Turn to Future Boat Ramp w/ Radius	482	4	215			215.4			
Rt. Sta 676 + 51 - 677 + 11	N. Boat Ramp Radius w/ Transition	87.6	11.75	126			126.4			
Rt. Sta 677 + 11 - 678 + 77		166.73	11.75	218			217.7			
Rt. Sta 678 + 77 - 680 + 0	Behind Guardrail	122.67	11.75	160			160.2			

# PAVING SCHEDULE

Location	Remarks	Length	Proposed Surface		40600200	40800050	42000411	48300410	X0712400	X0919000
			Width	Sq Yd	Bituminous Materials Prime Coat	Incidental Hot-Mix Asphalt Surfacing	Portland Cement Conc. Pavement 9 1/2" (Jointed)	Portland Cement Conc. Shoulders, 9 1/2"	Temporary Pavement	Temporary Pavement Removal
					Ton	Ton	Sq Yd	Sq Yd	Sq. Yd.	Sq. Yd.
<b>Left Side Shoulders</b>										
Lt. Sta. 604 + 14 - 604 + 40	Transition	25.84	VAR	16				0.0		
Lt. Sta. 604 + 40 - 615 + 0		1059.79	8	942				16.4		
Lt. Sta. 615 + 0 - 617 + 73		272.59	8	242				942.0		
Lt. Sta. 617 + 73 - 619 + 0	Around CE/PE at Lt. Sta. 618+04	127.41	8	113				242.3		
Lt. Sta. 619 + 0 - 626 + 57		757.4	8	673				113.3		
Lt. Sta. 626 + 57 - 626 + 86	Transition	28.56	VAR	21				673.2		
Lt. Sta. 626 + 86 - 627 + 64	South Radius (Margaret Fuller Rd.)	119	4	53				20.8		
Lt. Sta. 627 + 86 - 628 + 29	North Radius (Margaret Fuller Rd.)	91	4	40				52.9		
Lt. Sta. 628 + 29 - 630 + 58		229.04	4	104				40.4		
Lt. Sta. 630 + 58 - 631 + 30	South Radius (Blackhawk Vista)	115	4	51				103.5		
Lt. Sta. 631 + 53 - 631 + 99	North Radius (Blackhawk Vista)	84	4	37				51.1		
Lt. Sta. 631 + 99 - 634 + 23		224.55	4	101				37.3		
Lt. Sta. 634 + 23 - 634 + 99	South Radius (Cartwright Lane)	121	4	54				100.9		
Lt. Sta. 635 + 91 - 635 + 76	North Radius (Cartwright Lane)	89	4	40				53.8		
Lt. Sta. 635 + 76 - 638 + 0		223.66	4	99				39.6		
Lt. Sta. 638 + 0 - 638 + 72	Transition	72.32	VAR	53				99.4		
Lt. Sta. 638 + 72 - 641 + 79		306.36	8	272				53.3		
Lt. Sta. 641 + 79 - 642 + 10	Transition	31.46	VAR	22				272.3		
Lt. Sta. 642 + 10 - 643 + 88	South Radius (Access Road A)	127	4	111				21.5		
Lt. Sta. 643 + 47 - 643 + 53	North Radius (Access Road A)	115	4	88				111.0		
Lt. Sta. 643 + 53 - 647 + 54		401.88	4	182				88.2		
Lt. Sta. 647 + 54 - 648 + 57	Transition	102.17	VAR	77				181.6		
Lt. Sta. 648 + 57 - 660 + 0		1143.37	8	1016				77.3		
Lt. Sta. 660 + 0 - 675 + 0		1500	8	1333				1016.3		
Lt. Sta. 675 + 0 - 675 + 75		75.06	8	67				1333.3		
Lt. Sta. 675 + 75 - 676 + 3	Transition	28.1	VAR	18				66.7		
Lt. Sta. 676 + 68 - 677 + 18	North Radius (Stronghold Castle Rd.)	191	4	85				17.9		
Lt. Sta. 677 + 18 - 680 + 0		282.47	4	126				84.9		
<b>Widening for Staging</b>										
Lt. Sta. 680 + 0 - 682 + 79	AR Culvert 678+70 - STAGE 1	279.26	VAR	201				200.7		
Lt. Sta. 676 + 28 - 676 + 28	Stronghold Entrance - STAGE 1	37.50	20	83				83.3	83.3	
Rt. Sta. 669 + 50 - 673 + 0	AR Culvert 678+70 - STAGE 1	350.00	VAR	676				676.0	676.0	
Rt. Sta. 680 + 0 - 683 + 0	AR Culvert 678+70 - STAGE 1	300.00	VAR	316				316.5		
Lt. Sta. 618 + 0 - 619 + 77	STAGE 6 (Sta. 611+00 - 618+00)	177.00	VAR	180				179.9	179.9	
Rt. Sta. 617 + 12 - 618 + 0	STAGE 7 (Sta. 611+00 - 618+00)	87.66	VAR	33				33.2	33.2	
Lt. Sta. 615 + 36 - 621 + 79	STAGE 8 (Sta. 618+00 - 628+29)	643.38	VAR	210				209.9	209.9	
Lt. Sta. 628 + 28 - 630 + 97	STAGE 8 (Sta. 618+00 - 628+29)	268.84	VAR	313				313.1	313.1	
Rt. Sta. 629 + 44 - 635 + 0	STAGE 10 (Sta. 628+29 - 673+00)	556.00	VAR	368				367.7	367.7	
Rt. Sta. 635 + 0 - 640 + 50	STAGE 10 (Sta. 628+29 - 673+00)	550.00	VAR	455				454.9	454.9	
Rt. Sta. 640 + 50 - 646 + 0	STAGE 10 (Sta. 628+29 - 673+00)	550.00	VAR	380				380.3	380.3	
Rt. Sta. 646 + 0 - 651 + 50	STAGE 10 (Sta. 628+29 - 673+00)	550.00	VAR	598				597.9	597.9	
Rt. Sta. 651 + 50 - 657 + 0	STAGE 10 (Sta. 628+29 - 673+00)	550.00	VAR	889				888.6	888.6	
Rt. Sta. 657 + 0 - 661 + 47	STAGE 10 (Sta. 628+29 - 673+00)	446.93	VAR	538				538.0	538.0	
Rt. Sta. 662 + 22 - 662 + 50	STAGE 10 (Sta. 628+29 - 673+00)	28.15	VAR	32				32.0	32.0	
Rt. Sta. 662 + 50 - 668 + 0	STAGE 10 (Sta. 628+29 - 673+00)	550.00	VAR	1086				1085.6	1085.6	
Rt. Sta. 668 + 0 - 669 + 50	STAGE 10 (Sta. 628+29 - 673+00)	150.00	VAR	281				280.7	280.7	
Lt. & Rt. Sta. 626 + 61 - 667 + 20	Incidental Quantity for Temporary Patching at the Culverts (done by flaggers)	VAR	VAR	426			47.7			
<b>INTERMITTENT RESURFACING ON IL 2</b>										
Lt. & Rt. Sta. 664 + 0 - 712 + 36	SMART Resurfacing	4835.73	24	12895	18.4	1588.7				
Lt. & Rt. Sta. 729 + 37 - 752 + 50	SMART Resurfacing	2313.31	24	6169	8.8	760.0				
* Mainline quantities include PCC quantities for radii for all side roads except Access Rd A (see Pavement Joint Sheets)										
<b>TOTALS =</b>					33.2	3,056	37,576	12,898	6638.3	6121.1

# SUB-BASE SCHEDULE

Location	Remarks	Area	Breaker Run Depth	CA-02 Depth	CA-06 Depth	31100910	31100920	31100935	31100965	35101400	70005400
						Sub-base Granular Type A 12"	Sub-base Granular Type A 15"	Sub-base Granular Type A 18"	Sub-base Granular Type A 24"	Aggregate Base Course, Type B	Breaker Run Crushed Stone
		Sq Yd	Inch	Inch	Inch	Sq Yd	Sq Yd	Sq Yd	Sq Yd	Ton	Ton
<b>IL 2</b>											
LT/RT Sta 603 + 8 to 604 + 40	Mainline	984.2		9	3	984.2					
LT/RT Sta 604 + 40 to 615 + 00	Mainline	5149.0		9	3	5149.0					
LT/RT Sta 615 + 00 to 625 + 89	Mainline	5463.4		9	3	5463.4					
LT/RT Sta 625 + 89 to 626 + 89	Mainline	611.4	15		3				611.4		
LT/RT Sta 626 + 89 to 630 + 00	Mainline	2609.6		9	3	2609.6					
LT/RT Sta 630 + 00 to 635 + 89	Mainline	4984.5		9	3	4984.5					
LT/RT Sta 635 + 89 to 636 + 89	Mainline	694.6	15		3			694.6			
LT/RT Sta 636 + 89 to 640 + 89	Mainline	2588.6		9	3	2588.6					
LT/RT Sta 640 + 89 to 642 + 89	Mainline	1779.2	15		3			1779.2			
LT/RT Sta 642 + 89 to 645 + 00	Mainline	2155.7		9	3	2155.7					
LT/RT Sta 645 + 00 to 660 + 00	Mainline	9568.0		9	3	9568.0					
LT/RT Sta 660 + 00 to 675 + 00	Mainline	10280.4		9	3	10280.4					
LT/RT Sta 675 + 00 to 679 + 39	Mainline	3945.5		9	3	3945.5					
LT/RT Sta 679 + 39 to 680 + 00	Mainline	449.7	12		3		449.7				
<b>SIDEROADS</b>											
LT/RT Sta 16 + 75 to 18 + 76	Margaret Fuller Rd.	466.0	15		3					477.6	
LT/RT Sta 27 + 50 to 28 + 92	Blackhawk Vista	335.1	15		3					343.5	
LT/RT Sta 37 + 25 to 38 + 87	Cartwright Ln.	376.1	21		3					514.0	
	Over Look 1	2195.6	24							1500.3	342.9
LT/RT Sta 47 + 25 to 48 + 30	Access Road A	248.2		9	3					169.6	
LT/RT Sta 50 + 93 to 52 + 42	Access Road B	656.8	18		3					785.4	
LT/RT Sta 68 + 00 to 68 + 95	Stronghold Castle	343.6		9	3					234.8	
<b>TOTALS</b>						47729.0	449.7	2473.8	611.4	4025.3	342.9

# ENTRANCE SCHEDULE

Location	Remarks	Existing Surface past R.O.W.	Throat Width	Area	40600200	40800050	44000200	42300300	35101400	35101400			54205905	X0325666	54200220	54213450
					Bituminous Materials Prime Coat	Incidental Hot-Mix Asphalt Surfacing	Driveway Pavement Removal	PCC Driveway PAVT 7"	Aggregate Base Course Type B	Aggregate Base Course Type B (Temp Access)			Pipe Culverts, Type 1, Corrugated Steel, EQRS 30"	CSPMES Equiv. Double Round Size 30"	Pipe Culverts, Class D, Type 1 15"	End Sections 15"
					Ton	Ton	SQ YD	SQ YD	Ton	(PE) Ton	(CE) Ton	(FE) Ton	Foot	Each	Foot	Each
<b>IL 2</b>																
Lt Sta 610 + 73 PE		Concrete	19	66.7			66.7	66.7			30.5					
Lt Sta 612 + 5 PE		HMA	20	22.6	0.01	3.2		30.9	10.3	24.5						
Lt Sta 616 + 50 FE		Aggregate	24	97.4	0.06	13.6			44.6			44.6			52	2
Lt Sta 618 + 56 PE		Conc.w/ HMA Overlay	12	65.2	0.04	9.1	65.2		29.9	29.9					46	2
Lt Sta 622 + 53 PE		HMA	13	65.7	0.04	9.2			30.1	30.1						
Rt Sta 637 + 93 PE		HMA	10	132.0	0.08	18.5			60.4	60.4						
Lt Sta 641 + 57 PE		HMA	12	241.7	0.14	33.8			110.6	110.6			76		2	
Lt Sta 649 + 25 CE		HMA	24	257.3	0.15	36.0			117.8		117.8					
Lt Sta 651 + 36 PE		Aggregate	13	84.1	0.05	11.8			38.5	38.5					58	2
Lt Sta 652 + 37 PE		Aggregate	12	56.0	0.03	7.8			25.6	25.6						
Lt Sta 652 + 76 CE		HMA	30	92.1	0.05	12.9			42.2		42.2					
Lt Sta 653 + 91 CE		HMA	32	100.8	0.06	14.1			46.1		46.1					
Lt Sta 654 + 98 PE		Aggregate	12	62.1	0.04	8.7			28.4	28.4						
Lt Sta 662 + 71 PE		Aggregate	16	159.6	0.09	22.3			73.0	73.0						
Rt Sta 670 + 56 FE	Prop HMA to ExROW	Grass	24	280.0	0.05	13.1			128.2			128.2				
<b>Slideroad Entrances</b>																
Rt Sta 17 + 33 PE	Margaret Fuller Dr.	HMA	29	109.6	0.06	15.3			50.2	50.2					56	2
Lt Sta 17 + 38 PE	Margaret Fuller Dr.	HMA	15	88.8	0.05	12.4			40.6	40.6					124	2
Lt Sta 18 + 00 PE	Margaret Fuller Dr.	Concrete	24	98.0				98.0		44.9						
Lt Sta 28 + 64 PE	Blackhawk Vista	HMA	18	127.2	0.07	17.8			58.2	58.2					50	2
Lt Sta 37 + 93 PE	Cartwright Ln.	HMA	12	82.3	0.05	11.5			37.7	37.7						
Rt Sta 38 + 60 PE	Cartwright Ln.	HMA	18	144.1	0.08	20.2			66.0	66.0					52	2
Rt Sta 47 + 75 PE	Access Road A	Aggregate	11	57.9	0.03	8.1			26.5	26.5						
Lt Sta 47 + 86 CE	Access Road A	Aggregate	35	118.6	0.07	16.6			54.3		54.3				66	2
Rt Sta 48 + 12 PE	Access Road A	HMA	31	83.2	0.05	11.7			38.1	38.1					124	2
Sta 70 + 83 PE	Proposed Boat Ramp	Grass	20	214.3					98.1	98.1						
		Subtotal		2907.2	1.3	327.9	131.9	195.6	1255.6	912.0	260.4	172.8				
		Total		2907.2	1.3	327.9	131.9	195.6	2600.8				76	2	628	18



# PAVEMENT MARKING SCHEDULE

LOCATION	LT / RT	REMARKS	LENGTH (FT)	78008210	78008210	78008240	78008250	78008250	78008270	78008200	X7800610	X7800610	X7800640	70300625	70300660	70300610
				POLYUREA PVT. MARKING TYPE 1 - LINE 4" (WHITE) (FT)	POLYUREA PVT. MARKING TYPE 1 - LINE 4" (YELLOW) (FT)	POLYUREA PVT. MARKING TYPE 1 - LINE 8" (WHITE) (FT)	POLYUREA PVT. MARKING TYPE 1 - LINE 12" (YELLOW) (FT)	POLYUREA PVT. MARKING TYPE 1 - LINE 12" (WHITE) (FT)	POLYUREA PVT. MARKING TYPE 1 - LINE 24" (WHITE) (FT)	POLYUREA PVT. MARKING TYPE 1 - LETTERS & SYMBOLS (SQ FT)	URETHANE PVT. MARKING, LINE 4" (WHITE) (FT)	URETHANE PVT. MARKING, LINE 4" (YELLOW) (FT)	URETHANE PVT. MARKING, LINE 8" (WHITE) (FT)	TEMPORARY PAINT PAVEMENT MARKING LINE, 4" (FT)	TEMPORARY PAINT PAVEMENT MARKING LINE, 24" (FT)	TEMPORARY PVT. MARKING LETTERS & SYMBOLS (SQ FT)
WINTER SHUTDOWN QUANTITIES																
EDGE LINES																
IL 2																
604 + 40 to 620 + 42	RT	EDGE LINE	1602								1602			1602		
604 + 40 to 620 + 42	LT	EDGE LINE	1602								1602			1602		
620 + 42 to 634 + 49	RT	EDGE LINE	1407								1407			1407		
620 + 42 to 626 + 85	LT	EDGE LINE	643								643			643		
628 + 29 to 630 + 70	LT	EDGE LINE	241								241			241		
631 + 99 to 634 + 38	LT	EDGE LINE	239								239			239		
635 + 62 to 637 + 0	RT	EDGE LINE	138								138			138		
635 + 77 to 641 + 82	LT	EDGE LINE	606								606			606		
638 + 15 to 641 + 69	RT	EDGE LINE	354								354			354		
643 + 53 to 645 + 00	LT	EDGE LINE	147								147			147		
643 + 74 to 645 + 00	RT	EDGE LINE	126								126			126		
645 + 00 to 660 + 00	LT	EDGE LINE	1500								1500			1500		
645 + 00 to 660 + 00	RT	EDGE LINE	1500								1500			1500		
660 + 00 to 675 + 00	LT	EDGE LINE	1500								1500			1500		
660 + 00 to 661 + 39	RT	EDGE LINE	139								139			139		
662 + 83 to 675 + 00	RT	EDGE LINE	1217								1217			1217		
675 + 00 to 675 + 64	LT	EDGE LINE	64								64			127		
675 + 00 to 675 + 75	RT	EDGE LINE	75								75			150		
677 + 11 to 680 + 00	RT	EDGE LINE	289								289			579		
677 + 20 to 680 + 00	LT	EDGE LINE	280								280			559		
680 + 00 to 683 + 00	RT	EDGE LINE	300											900		
680 + 00 to 683 + 00	LT	EDGE LINE	300											900		
683 + 00 to 712 + 36	RT	EDGE LINE	2936											2936		
683 + 00 to 712 + 36	LT	EDGE LINE	1936											1936		
729 + 37 to 752 + 50	RT	EDGE LINE	2313											2313		
729 + 37 to 752 + 50	LT	EDGE LINE	2313											2313		
FAIR ST.																
249 + 00 to 249 + 57	LT	EDGE LINE	108		108									108		
249 + 00 to 250 + 00	RT	EDGE LINE	112		112									112		
MARGARET FULLER RD.																
16 + 75 to 19 + 22	LT	EDGE LINE	300		300									300		
16 + 75 to 20 + 3	RT	EDGE LINE	352		352									352		
BLACKHAWK VISTA																
27 + 50 to 29 + 40	LT	EDGE LINE	233		233									233		
27 + 50 to 29 + 84	RT	EDGE LINE	261		261									261		
CARTWRIGHT LANE																
37 + 25 to 39 + 34	LT	EDGE LINE	259		259									259		
37 + 25 to 39 + 88	RT	EDGE LINE	289		289									289		
OVERLOOK NO. 1																
	LT	EDGE LINE	238		238									238		
	RT	EDGE LINE	456		456									456		
ACCESS RD. A																
47 + 50 to 49 + 13	LT	EDGE LINE	204		204									204		
47 + 50 to 50 + 7	RT	EDGE LINE	280		280									280		
ACCESS RD. B																
50 + 45 to 52 + 57	LT	EDGE LINE	309		309									309		
50 + 2 to 52 + 34	RT	EDGE LINE	269		269									269		
CULTRA RD.																
60 + 17 to 60 + 80	LT	EDGE LINE	101		101									101		
60 + 20 to 60 + 80	RT	EDGE LINE	91		91									91		
STRONGHOLD CASTLE																
68 + 00 to 69 + 56	LT	EDGE LINE	196		196									196		
68 + 00 to 69 + 79	RT	EDGE LINE	209		209									209		
FUTURE BOAT RAMP																
70 + 12 to 70 + 84	LT	EDGE LINE	107		107									107		
70 + 24 to 70 + 84	RT	EDGE LINE	95		95									95		
CENTERLINE MAINLINE																
604 + 21 to 620 + 42	CL	DOUBLE YELLOW	1621									3242		3242		
664 + 00 to 687 + 70	CL	DOUBLE YELLOW	2371											4742		
687 + 70 to 692 + 17	CL	(N.B.) PASSING SKIPS	448											120		
687 + 70 to 692 + 17	CL	(S.B.) NO PASSING	448											448		
692 + 17 to 702 + 21	CL	PASSING ZONE	1004											260		
702 + 21 to 712 + 36	CL	(N.B.) NO PASSING	1016											1016		
702 + 21 to 712 + 36	CL	(S.B.) PASSING SKIPS	1016											260		
729 + 37 to 752 + 50	CL	PASSING ZONE	2313											580		

# PAVEMENT MARKING SCHEDULE

LOCATION	LT / RT	REMARKS	LENGTH (FT)	78008210	78008210	78008240	78008250	78008250	78008270	78008200	7800610	7800610	7800640	70300625	70300660	70300610	
				POLYUREA PVT. MARKING TYPE 1 - LINE 4" (WHITE) (FT)	POLYUREA PVT. MARKING TYPE 1 - LINE 4" (YELLOW) (FT)	POLYUREA PVT. MARKING TYPE 1 - LINE 8" (WHITE) (FT)	POLYUREA PVT. MARKING TYPE 1 - LINE 12" (YELLOW) (FT)	POLYUREA PVT. MARKING TYPE 1 - LINE 12" (WHITE) (FT)	POLYUREA PVT. MARKING TYPE 1 - LINE 24" (WHITE) (FT)	POLYUREA PVT. MARKING TYPE 1 - LINE 24" (WHITE) (FT)	POLYUREA PVT. MARKING TYPE 1 - LINE 24" (WHITE) (FT)	POLYUREA PVT. MARKING TYPE 1 - LINE 24" (WHITE) (FT)	POLYUREA PVT. MARKING TYPE 1 - LINE 24" (WHITE) (FT)	POLYUREA PVT. MARKING TYPE 1 - LINE 24" (WHITE) (FT)	URETHANE PVT. MARKING, LINE 4" (WHITE) (FT)	URETHANE PVT. MARKING, LINE 4" (YELLOW) (FT)	URETHANE PVT. MARKING, LINE 8" (WHITE) (FT)
WINTER SHUTDOWN QUANTITIES																	
CENTERLINE SIDEROADS																	
FAIR ST.																	
249 + 00 to 249 + 77	CL	SKIP DASHES	77		20										20		
249 + 70	RT	STOP BAR	15							15						15	
MARGARET FULLER RD.																	
16 + 75 to 19 + 36	CL	SKIP DASHES	261	70										70			
19 + 35	RT	STOP BAR	16							16						16	
BLACKHAWK VISTA																	
27 + 50 to 29 + 43	CL	SKIP DASHES	193	50													
29 + 43	RT	STOP BAR	15							15							
CARTWRIGHT LANE																	
37 + 25 to 39 + 42	CL	SKIP DASHES	217	60													
39 + 42	RT	STOP BAR	15							15							
ACCESS RD. A																	
47 + 50 to 49 + 34	CL	SKIP DASHES	184	50													
49 + 34	RT	STOP BAR	14							14							
ACCESS RD. B																	
50 + 63 to 52 + 42	CL	SKIP DASHES	179	50													
50 + 63	LT	STOP BAR	19							19							
CULTRA RD.																	
60 + 42 to 60 + 80	CL	SKIP DASHES	38	10													
60 + 42	LT	STOP BAR	25							25							
STRONGHOLD CASTLE																	
68 + 00 to 69 + 44	CL	SKIP DASHES	144	40										40			
69 + 44	RT	STOP BAR	19							19						19	
FUTURE BOAT RAMP																	
70 + 42 to 70 + 85	CL	SKIP DASHES	43	20										20			
70 + 42	RT	STOP BAR	20							20						20	
ISLANDS / TURN BAYS																	
620 + 42 to 626 + 77	CL	MEDIAN OUTSIDE LINES	1274		1274										1274		
	CL	MEDIAN INSIDE LINES	666		666										666		
	CL	MEDIAN DIAGONALS	95				95								95		
625 + 62 to 626 + 77	CL	TURN BAY LINE	115										115		115		
625 + 82	RT	LT. TURN ARROWS	-							15.6						15.6	
626 + 20	RT	LT. TURN ARROWS	-							15.6						15.6	
626 + 57	RT	LT. TURN ARROWS	-							15.6						15.6	
627 + 57 to 630 + 70	CL	MEDIAN OUTSIDE LINES	635		635										635		
	CL	MEDIAN INSIDE LINES	304		304										304		
	CL	MEDIAN DIAGONALS	85				85								85		
629 + 55 to 630 + 70	CL	TURN BAY LINE	115										115		115		
628 + 00 to 629 + 55	CL	TURKEY TRACKS	155										52		80		
629 + 75	LT	LT. TURN ARROWS	-							15.6						15.6	
630 + 12	LT	LT. TURN ARROWS	-							15.6						15.6	
630 + 50	LT	LT. TURN ARROWS	-							15.6						15.6	
627 + 51 to 628 + 00	LT	ISLAND OUTSIDE LINES	138			138									138		
627 + 51 to 628 + 00	LT	ISLAND INSIDE LINES	229					229							229		
628 + 00 to 629 + 44	LT	TURN BAY LINE	144			144											
628 + 50	LT	RT. TURN ARROWS	-							15.6						15.6	
628 + 87	LT	RT. TURN ARROWS	-							15.6						15.6	
629 + 24	LT	RT. TURN ARROWS	-							15.6						15.6	
631 + 36 to 634 + 38	CL	MEDIAN OUTSIDE LINES	612		612												
	CL	MEDIAN INSIDE LINES	290		290												
	CL	MEDIAN DIAGONALS	57				57										
633 + 23 to 634 + 38	CL	TURN BAY LINE	115										115				
631 + 70 to 633 + 23	CL	TURKEY TRACKS	153										52				
633 + 43	RT	RT. TURN ARROWS	-							15.6						15.6	
633 + 80	RT	RT. TURN ARROWS	-							15.6						15.6	
634 + 18	RT	RT. TURN ARROWS	-							15.6						15.6	
633 + 43	RT	THRU ARROWS	-							11.5						11.5	
633 + 80	RT	THRU ARROWS	-							11.5						11.5	
634 + 18	RT	THRU ARROWS	-							11.5						11.5	
633 + 43	LT	LT. TURN ARROWS	-							15.6						15.6	
633 + 80	LT	LT. TURN ARROWS	-							15.6						15.6	
634 + 18	LT	LT. TURN ARROWS	-							15.6						15.6	
631 + 33 to 631 + 69	LT	ISLAND OUTSIDE LINES	117			117											
631 + 33 to 631 + 69	LT	ISLAND INSIDE LINES	177					177									
631 + 69 to 633 + 12	LT	TURN BAY LINE	144			144											
631 + 84	LT	RT. TURN ARROWS	-							15.6						15.6	
632 + 37	LT	RT. TURN ARROWS	-							15.6						15.6	
632 + 92	LT	RT. TURN ARROWS	-							15.6						15.6	

# PAVEMENT MARKING SCHEDULE

LOCATION	LT / RT	REMARKS	LENGTH (FT)	78008210	78008210	78008240	78008250	78008250	78008270	78008200	X7800610	X7800610	X7800640	70300625	70300660	70300610	
				POLYUREA PVT. MARKING TYPE 1 - LINE 4" (WHITE) (FT)	POLYUREA PVT. MARKING TYPE 1 - LINE 4" (YELLOW) (FT)	POLYUREA PVT. MARKING TYPE 1 - LINE 8" (WHITE) (FT)	POLYUREA PVT. MARKING TYPE 1 - LINE 12" (YELLOW) (FT)	POLYUREA PVT. MARKING TYPE 1 - LINE 12" (WHITE) (FT)	POLYUREA PVT. MARKING TYPE 1 - LINE 24" (WHITE) (FT)	POLYUREA PVT. MARKING TYPE 1 - LINE 24" (WHITE) (FT)	POLYUREA PVT. MARKING TYPE 1 - LINE 24" (WHITE) (FT)	POLYUREA PVT. MARKING TYPE 1 - LINE 24" (WHITE) (FT)	POLYUREA PVT. MARKING TYPE 1 - LINE 24" (WHITE) (FT)	POLYUREA PVT. MARKING TYPE 1 - LINE 24" (WHITE) (FT)	URETHANE PVT. MARKING, LINE 4" (WHITE) (FT)	URETHANE PVT. MARKING, LINE 4" (YELLOW) (FT)	URETHANE PVT. MARKING, LINE 8" (WHITE) (FT)
WINTER SHUTDOWN QUANTITIES																	
633 + 23 to 634 + 49	RT	TURN BAY LINE	126														126
631 + 43 to 633 + 23	RT	TURKEY TRACKS	180														62
633 + 43	RT	RT. TURN ARROWS	-							15.6							
633 + 80	RT	RT. TURN ARROWS	-							15.6							
634 + 18	RT	RT. TURN ARROWS	-							15.6							
635 + 45 to 637 + 21	LT	MEDIAN LINES	175														
635 + 45 to 637 + 21	LT	THRU LANE	176										354				176
635 + 71	LT	LT. TURN ARROWS	-							15.6							
636 + 23	LT	LT. TURN ARROWS	-							15.6							
636 + 73	LT	LT. TURN ARROWS	-							15.6							
635 + 5 to 635 + 48	LT	ISLAND OUTSIDE LINES	120			120											
635 + 5 to 635 + 48	LT	ISLAND INSIDE LINES	177					177									
635 + 62 to 637 + 2	LT	PARKING (OVERLOOK NO. 1)	140		220												
635 + 47 to 636 + 92	LT	TURN BAY LINE (CARTWRIGHT LN.)	145			145											
636 + 92 to 638 + 54	LT	TURKEY TRACKS	162														56
635 + 71	LT	RT. TURN ARROWS	-							15.6							
636 + 23	LT	RT. TURN ARROWS	-							15.6							
636 + 73	LT	RT. TURN ARROWS	-							15.6							
637 + 92 to 641 + 81	LT	MEDIAN LINES	388														
637 + 92 to 638 + 85	LT	TURN BAY LINE (OVERLOOK NO.1)	93										780				93
638 + 12	LT	LT. TURN ARROWS	-							15.6							
638 + 66	LT	LT. TURN ARROWS	-							15.6							
638 + 85 to 640 + 51	LT	TURKEY TRACKS	166														56
638 + 69 to 640 + 49	RT	TURKEY TRACKS	180														60
640 + 49 to 641 + 81	RT	TURN BAY LINE (ACCESS RD. B)	132														132
640 + 86	RT	RT. TURN ARROWS	-							15.6							
641 + 23	RT	RT. TURN ARROWS	-							15.6							
641 + 60	RT	RT. TURN ARROWS	-							15.6							
640 + 66 to 641 + 81	CL	TURN BAY LINE (ACCESS RD. A)	115														115
638 + 86 to 640 + 66	CL	TURKEY TRACKS	180														62
640 + 86	LT	LT. TURN ARROWS	-							15.6							
641 + 23	LT	LT. TURN ARROWS	-							15.6							
641 + 60	LT	LT. TURN ARROWS	-							15.6							
643 + 13 to 646 + 6	LT	MEDIAN OUTSIDE LINES	585										585				
646 + 6 to 661 + 78	LT	MEDIAN OUTSIDE LINES	3175		3175												
	LT	MEDIAN INSIDE LINES	3080		3080												
	LT	MEDIAN DIAGONALS	749					749									
643 + 13 to 646 + 6	LT	TURN BAY (ACCESS B)	292														292
646 + 6 to 648 + 56	LT	TURKEY TRACKS	250														64
643 + 76	LT	LT. TURN ARROWS	-							15.6							
644 + 47	LT	LT. TURN ARROWS	-							15.6							
645 + 17	LT	LT. TURN ARROWS	-							15.6							
645 + 86	LT	LT. TURN ARROWS	-							15.6							
642 + 86 to 643 + 27	LT	ISLAND OUTSIDE LINES	130			130											
642 + 86 to 643 + 27	LT	ISLAND INSIDE LINES	190					190									
643 + 25 to 646 + 6	LT	TURN BAY (ACCESS A)	281			281											
646 + 6 to 648 + 56	LT	TURKEY TRACKS	250														64
643 + 76	LT	RT. TURN ARROWS	-							15.6							
644 + 47	LT	RT. TURN ARROWS	-							15.6							
645 + 17	LT	RT. TURN ARROWS	-							15.6							
645 + 86	LT	RT. TURN ARROWS	-							15.6							
658 + 86 to 661 + 75	RT	TURN BAY LINE (CULTRA RD.)	288														288
659 + 6	RT	RT. TURN ARROWS	-							15.6							
659 + 76	RT	RT. TURN ARROWS	-							15.6							
660 + 46	RT	RT. TURN ARROWS	-							15.6							
661 + 16	RT	RT. TURN ARROWS	-							15.6							



# PAVEMENT MARKING SCHEDULE

LOCATION	LT / RT	REMARKS	LENGTH (FT)	78008210	78008210	78008240	78008250	78008250	78008270	78008200	X7800610	X7800610	X7800640	70300625	70300660	70300610
				POLYUREA PVT. MARKING TYPE 1 - LINE 4" (WHITE) (FT)	POLYUREA PVT. MARKING TYPE 1 - LINE 4" (YELLOW) (FT)	POLYUREA PVT. MARKING TYPE 1 - LINE 8" (WHITE) (FT)	POLYUREA PVT. MARKING TYPE 1 - LINE 12" (YELLOW) (FT)	POLYUREA PVT. MARKING TYPE 1 - LINE 12" (WHITE) (FT)	POLYUREA PVT. MARKING TYPE 1 - LINE 24" (WHITE) (FT)	POLYUREA PVT. MARKING TYPE 1 - LETTERS & SYMBOLS ( SQ FT)	URETHANE PVT. MARKING, LINE 4" (WHITE) (FT)	URETHANE PVT. MARKING, LINE 4" (YELLOW) (FT)	URETHANE PVT. MARKING, LINE 8" (WHITE) (FT)	TEMPORARY PAINT PAVEMENT MARKING LINE, 4" (FT)	TEMPORARY PAINT PAVEMENT MARKING LINE, 24" (FT)	TEMPORARY PVT. MARKING LETTERS & SYMBOLS ( SQ FT)
WINTER SHUTDOWN QUANTITIES																
662 + 59 to 665 + 9	LT	MEDIAN OUTSIDE LINES	500										500			
665 + 9 to 673 + 21	LT	MEDIAN OUTSIDE LINES	1628		1628											
673 + 21 to 675 + 83	LT	MEDIAN OUTSIDE LINES	525										525			
	LT	MEDIAN INSIDE LINES	1358		1358											
	LT	MEDIAN DIAGONALS	310				310									
662 + 59 to 665 + 9	LT	TURN BAY LINE (CULTRA RD.)	250										250			
662 + 79	LT	LT. TURN ARROWS	-							15.6						
663 + 49	LT	LT. TURN ARROWS	-							15.6						
664 + 19	LT	LT. TURN ARROWS	-							15.6						
664 + 89	LT	LT. TURN ARROWS	-							15.6						
673 + 21 to 675 + 83	LT	TURN BAY LINE (STRONGHOLD)	262										262	262		
673 + 41	LT	LT. TURN ARROWS	-							15.6						15.6
674 + 11	LT	LT. TURN ARROWS	-							15.6						15.6
674 + 81	LT	LT. TURN ARROWS	-							15.6						15.6
675 + 51	LT	LT. TURN ARROWS	-							15.6						15.6
673 + 21 to 675 + 83	RT	TURN BAY LINE (BOAT RAMP)	262										262	262		
673 + 41	RT	RT. TURN ARROWS	-							15.6						15.6
674 + 11	RT	RT. TURN ARROWS	-							15.6						15.6
674 + 81	RT	RT. TURN ARROWS	-							15.6						15.6
675 + 51	RT	RT. TURN ARROWS	-							15.6						15.6
677 + 5 to 680 + 00	LT	DOUBLE YELLOW	295										590		590	
677 + 5 to 679 + 85	LT	TURN BAY LINE (F. BOAT RAMP)	280										280	280		
679 + 85 to 680 + 00	LT	TURKEY TRACKS	15										4	4		
677 + 29	LT	LT. TURN ARROWS	-							15.6						15.6
678 + 5	LT	LT. TURN ARROWS	-							15.6						15.6
678 + 96	LT	LT. TURN ARROWS	-							15.6						15.6
679 + 66	LT	LT. TURN ARROWS	-							15.6						15.6
677 + 5 to 679 + 85	LT	TURN BAY LINE (STRONGHOLD)	280										280	280		
679 + 85 to 680 + 00	LT	TURKEY TRACKS	15										4	4		
677 + 29	LT	RT. TURN ARROWS	-							15.6						15.6
678 + 5	LT	RT. TURN ARROWS	-							15.6						15.6
678 + 96	LT	RT. TURN ARROWS	-							15.6						15.6
679 + 66	LT	RT. TURN ARROWS	-							15.6						15.6
680 + 00 to 684 + 6	LT	DOUBLE YELLOW	406												1624	
680 + 00 to 682 + 24	LT	TURKEY TRACKS	224												116	
680 + 00 to 681 + 38	LT	TURKEY TRACKS	138												72	
Subtotal				4,469	13,612		1,296	773			13,670	6,576				
TOTAL				18,081		1,218	2,069		158	1,080	20,246	3,437	49,410	70	343	

FILE NAME =	USER NAME = perknsdr	DESIGNED -	REVISED -	<b>STATE OF ILLINOIS DEPARTMENT OF TRANSPORTATION</b>	<b>PAVEMENT MARKING SCHEDULE</b>	F.A.P. RTE. 742	SECTION 37R-3	COUNTY OGLE	TOTAL SHEETS 345	SHEET NO. 48		
	PLOT SCALE = 50,0000' / IN.	CHECKED -	REVISED -			CONTRACT NO. 84788						
	PLOT DATE = Mon Jun 08 11:19:09 2009	DATE -	REVISED -			SCALE:		SHEET NO. OF SHEETS STA. TO STA.		FED. ROAD DIST. NO. ILLINOIS FED. AID PROJECT		

# RAISED REFLECTOR SCHEDULE

										78100100
LOCATION										RAISED REFLECTIVE PAVEMENT MARKERS (EACH)
										(EACH)
IL 2										
LOCATION	LT /	SPACING	REMARKS	TYPE						
603 + 60 to 620 + 42	CL	80' o.c.	CENTERLINE	TWO-WAY AMBER						21
620 + 42 to 626 + 77	LT	40' o.c.	MEDIAN	TWO-WAY AMBER						17
620 + 42 to 624 + 00	LT	40' o.c.	MEDIAN	TWO-WAY AMBER						10
624 + 20 to 626 + 77	LT	20' o.c.	MEDIAN	TWO-WAY AMBER						13
625 + 62 to 626 + 77	RT	20' o.c.	TURN-BAY	ONE-WAY CRYSTAL						7
627 + 57 to 630 + 70	LT	40' o.c.	MEDIAN	TWO-WAY AMBER						9
627 + 57 to 628 + 20	LT	40' o.c.	MEDIAN	TWO-WAY AMBER						4
628 + 20 to 630 + 70	LT	20' o.c.	MEDIAN	TWO-WAY AMBER						13
627 + 51 to 629 + 44	RT	20' o.c.	TURN-BAY	ONE-WAY CRYSTAL						11
629 + 55 to 630 + 70	RT	20' o.c.	TURN-BAY	ONE-WAY CRYSTAL						7
631 + 36 to 634 + 48	LT	40' o.c.	MEDIAN	TWO-WAY AMBER						9
631 + 36 to 631 + 64	LT	20' o.c.	MEDIAN	TWO-WAY AMBER						3
631 + 64 to 634 + 38	LT	20' o.c.	MEDIAN	TWO-WAY AMBER						14
631 + 33 to 633 + 12	LT	20' o.c.	TURN-BAY	ONE-WAY CRYSTAL						10
633 + 23 to 634 + 38	RT	20' o.c.	TURN-BAY	ONE-WAY CRYSTAL						7
633 + 23 to 634 + 49	RT	20' o.c.	TURN-BAY	ONE-WAY CRYSTAL						7
635 + 5 to 636 + 94	LT	20' o.c.	TURN-BAY	ONE-WAY CRYSTAL						10
635 + 45 to 637 + 21	LT	20' o.c.	TURN-BAY	ONE-WAY CRYSTAL						10
635 + 45 to 637 + 21	RT	40' o.c.	MEDIAN	TWO-WAY AMBER						6
637 + 92 to 640 + 52	LT	20' o.c.	MEDIAN	TWO-WAY AMBER						14
640 + 52 to 641 + 80	LT	40' o.c.	MEDIAN	TWO-WAY AMBER						3
637 + 92 to 638 + 85	LT	20' o.c.	TURN-BAY	ONE-WAY CRYSTAL						6
637 + 92 to 638 + 72	RT	40' o.c.	MEDIAN	TWO-WAY AMBER						3
638 + 72 to 641 + 80	LT	20' o.c.	MEDIAN	TWO-WAY AMBER						15
640 + 49 to 641 + 80	RT	20' o.c.	TURN-BAY	ONE-WAY CRYSTAL						8
640 + 66 to 641 + 80	RT	20' o.c.	TURN-BAY	ONE-WAY CRYSTAL						7
642 + 86 to 646 + 6	LT	20' o.c.	TURN-BAY	ONE-WAY CRYSTAL						17
643 + 13 to 646 + 6	LT	20' o.c.	TURN-BAY	ONE-WAY CRYSTAL						17
643 + 13 to 661 + 78	RT	40' o.c.	MEDIAN	TWO-WAY AMBER						48
643 + 13 to 648 + 75	LT	20' o.c.	MEDIAN	TWO-WAY AMBER						29
648 + 75 to 661 + 78	LT	40' o.c.	MEDIAN	TWO-WAY AMBER						34
658 + 86 to 661 + 75	RT	20' o.c.	TURN-BAY	ONE-WAY CRYSTAL						15
662 + 59 to 665 + 9	LT	20' o.c.	TURN-BAY	ONE-WAY CRYSTAL						14
662 + 59 to 667 + 79	LT	20' o.c.	MEDIAN	TWO-WAY AMBER						27
667 + 79 to 675 + 83	LT	40' o.c.	MEDIAN	TWO-WAY AMBER						20
662 + 59 to 671 + 00	RT	40' o.c.	MEDIAN	TWO-WAY AMBER						22
671 + 00 to 675 + 83	RT	20' o.c.	MEDIAN	TWO-WAY AMBER						24
673 + 21 to 675 + 83	RT	20' o.c.	TURN-BAY	ONE-WAY CRYSTAL						14
673 + 21 to 675 + 83	RT	20' o.c.	TURN-BAY	ONE-WAY CRYSTAL						14
677 + 5 to 679 + 85	LT	20' o.c.	TURN-BAY	ONE-WAY CRYSTAL						15
677 + 5 to 679 + 85	LT	20' o.c.	TURN-BAY	ONE-WAY CRYSTAL						15
677 + 5 to 680 + 00	LT	20' o.c.	MEDIAN	TWO-WAY AMBER						15
677 + 5 to 680 + 00	RT	40' o.c.	MEDIAN	TWO-WAY AMBER						8
Subtotal Two-way Amber										391
Subtotal One-way Crystal										211
TOTAL										602

# TREE REMOVAL SCHEDULE

20100110 TREE REMOVAL (6 TO 15 UNITS DIAMETER)

STATION	LT/RT	OFFSET	UNIT
603+79.52	RT	26.26	7.2
603+96.28	RT	25.16	6.3
608+76.14	RT	26.17	8
608+77.76	RT	24.63	8
608+78.80	RT	26.90	8
608+80.07	RT	25.76	10
610+59.55	LT	43.10	15
610+63.68	LT	46.89	6
613+41.56	LT	34.68	10
615+10.98	RT	40.17	6.4
615+22.98	RT	38.12	12.8
615+23.77	RT	38.12	12.2
615+29.14	RT	41.77	8.3
615+40.61	RT	32.71	6.2
615+41.49	RT	32.71	6.2
615+76.34	LT	30.75	13.5
615+77.87	LT	31.84	9
618+37.93	LT	47.05	7
626+50.53	RT	42.04	6.2
626+75.87	RT	34.97	6.7
627+03.18	RT	46.99	7.5
627+03.49	LT	57.86	11
627+04.45	RT	46.28	6
627+74.20	LT	38.87	8
627+76.17	LT	46.46	6.4
627+76.28	LT	45.76	7.2
627+77.40	LT	46.78	6.3
627+82.19	LT	58.77	6.1
627+85.94	LT	37.57	7.2
627+92.34	LT	39.84	8.6
627+93.19	LT	72.20	10.5
627+94.90	LT	73.12	10.5
627+95.06	LT	37.88	10
628+28.82	LT	50.03	10
628+44.61	LT	37.95	6.2
628+54.26	LT	39.61	9.8
628+92.23	RT	41.52	12.6
629+17.26	LT	39.83	13.1
629+17.54	LT	44.05	8.6
629+60.65	LT	39.63	9.3
629+61.27	LT	40.56	10
629+71.15	LT	40.64	8
629+80.91	LT	40.20	7.8
629+86.87	LT	41.31	12.2
629+96.13	LT	54.39	14.3
630+19.41	LT	68.54	7.1
630+32.34	LT	61.01	11
630+54.59	LT	59.73	8.2
630+59.32	RT	53.75	14.7
630+62.55	LT	43.90	6.2
630+77.97	LT	49.58	14.4
634+72.53	LT	84.36	6.7
634+79.38	LT	127.43	14.7
634+90.13	RT	37.77	10.2
635+09.85	RT	50.31	6.5
635+12.96	RT	49.75	11.8
635+14.78	RT	56.82	6.7
635+15.89	RT	57.41	8.7
635+17.65	RT	64.41	7.5
635+18.46	RT	53.32	8.7
635+20.15	RT	54.65	8.8
635+20.73	RT	53.90	8.8
635+23.18	RT	52.06	8.7
635+23.54	RT	52.89	10.2
635+23.67	RT	67.78	6.6
635+30.94	RT	71.75	7.2
635+31.39	RT	68.56	6.3
635+34.13	RT	70.59	6
635+53.61	RT	63.17	6.2
635+54.55	RT	60.43	6.2
635+54.62	RT	62.75	9.1

635+54.80	RT	67.07	6.6
635+55.39	RT	42.99	6.2
635+56.37	RT	44.12	7.6
635+58.05	RT	66.89	7
635+58.38	RT	51.86	8.2
635+63.93	RT	68.67	6.3
635+63.97	RT	64.01	7.2
635+67.00	RT	68.25	7.5
635+68.39	RT	66.06	9.1
635+89.10	RT	60.38	7
635+94.64	RT	67.85	6
636+07.99	RT	63.88	10.6
636+13.66	RT	70.98	6.2
636+14.52	RT	67.16	6.1
636+15.98	RT	67.22	8.7
636+17.81	RT	63.03	10
636+20.30	RT	58.72	6
636+22.47	RT	70.92	7.5
636+27.51	RT	71.19	8.2
637+13.10	RT	88.00	10.4
637+30.46	RT	89.31	14.7
642+85.50	LT	130.64	14.4
643+01.74	LT	146.12	9.8
651+99.89	LT	46.62	14.1
652+08.85	LT	43.13	12.8
652+18.26	LT	43.23	10.8
652+20.99	LT	43.41	10.3
654+26.14	LT	55.32	9.3
659+17.09	RT	62.54	13.4
662+41.00	RT	63.53	12.7
662+94.75	LT	51.80	6.1
663+05.73	LT	60.98	9.7
663+08.61	LT	61.61	6
663+17.27	LT	62.21	8.4
663+37.87	LT	57.61	6.2
663+69.61	LT	58.39	6.2
665+01.98	LT	53.71	9.5
667+10.98	RT	50.57	6.1
667+16.12	RT	48.37	12
667+33.19	LT	58.06	6.2
667+62.67	LT	54.25	11.2
670+41.38	RT	94.87	12.5
670+44.56	RT	59.55	10.7
673+16.57	LT	44.68	11.8
673+46.79	LT	43.44	9.5
673+71.99	LT	38.04	6
673+88.82	RT	69.72	13.1
673+89.25	LT	38.82	15
673+89.31	RT	58.34	10.2
673+95.15	RT	69.40	13
673+95.92	RT	57.52	14.6
674+02.48	RT	69.01	12.6
674+02.54	RT	58.04	12.8
674+28.49	RT	66.47	12.2
674+31.33	RT	56.42	13.1
674+42.35	RT	67.71	14
674+53.70	RT	68.03	12.2
674+62.99	LT	44.60	6.2
674+69.24	RT	68.91	14.1
674+72.49	RT	69.15	9.8
674+73.66	RT	67.92	9.8
675+12.05	RT	66.78	7.7
675+13.96	RT	67.01	12.7
675+14.94	RT	64.15	9
675+15.28	RT	66.18	12.1
675+15.66	RT	67.96	12.3
675+16.60	RT	64.41	11.3
675+19.16	RT	66.75	11
675+20.50	RT	64.14	7.1
675+27.87	RT	54.11	13.2
675+28.02	RT	54.09	13.2
675+38.04	RT	65.68	7.5
675+40.91	LT	47.96	9.7
675+46.00	RT	66.40	9.8
675+46.14	LT	54.35	6.5
675+50.67	RT	65.72	11.8

675+63.47	RT	65.21	11.2
675+80.61	RT	64.37	10.9
675+83.19	RT	64.57	9.2
675+89.37	RT	64.60	10.5
675+95.47	RT	64.36	12
676+08.12	RT	63.76	9.1
676+11.61	RT	74.77	9.4
676+12.19	RT	76.82	9.2
676+12.51	RT	73.66	7.4
676+13.58	RT	72.65	6.2
676+14.36	RT	73.92	9.5
676+14.43	RT	63.76	10
676+14.75	RT	77.53	9.7
676+15.25	RT	76.36	9.3
676+15.46	RT	75.64	7
676+15.84	RT	73.23	15
676+52.97	RT	83.43	9.6
676+53.63	RT	85.39	14.2
676+53.98	RT	63.43	14.2
676+56.22	RT	73.35	8.8
676+61.95	RT	84.85	12.8
676+62.42	RT	85.78	13.6
676+73.98	RT	72.45	14.5
677+25.87	LT	75.89	6.1
677+26.42	LT	75.05	12.3
677+26.72	LT	76.44	6.1
677+29.12	LT	75.61	6.2
677+43.16	LT	69.86	14.7
677+70.85	LT	68.19	7.8
677+74.41	LT	68.23	7
677+78.31	RT	32.53	11.4
677+80.59	RT	50.48	7.1
677+81.48	LT	92.38	12.1
677+83.93	RT	52.78	9.7
677+85.58	RT	37.74	14.3
677+94.94	LT	81.55	8.7
677+97.80	RT	63.93	11.2
677+98.19	LT	57.47	11.4
678+01.06	RT	33.02	6.8
678+02.45	LT	86.68	10.7
678+05.59	RT	39.99	10.2
678+06.58	RT	39.48	6
678+13.18	RT	56.97	13.2
678+20.02	LT	68.23	13.7
678+25.71	RT	75.66	7.2
678+26.62	RT	75.16	12.6
678+27.92	RT	75.64	8.6
678+28.15	LT	57.80	8.4
678+29.23	RT	71.77	12.5
678+31.53	LT	77.00	10.9
678+51.98	LT	70.70	7.7
678+59.47	RT	70.08	6.5
678+97.75	LT	64.18	6.7
678+98.69	RT	64.09	9.1
679+00.85	LT	63.48	11
679+03.89	LT	67.31	10.8
679+08.31	RT	59.06	6
679+13.87	RT	40.84	6.2
679+14.66	RT	50.57	6.2
679+21.06	LT	63.13	10.8
679+23.98	RT	59.13	9.8
679+27.62	RT	63.87	7.3
679+30.75	RT	53.48	6.8
679+37.99	RT	68.49	12.2
679+38.00	RT	68.38	11.7
679+48.17	LT	66.48	6.8
679+50.76	LT	56.76	12.6
679+56.35	RT	62.32	8.7
679+61.87	LT	58.70	6.2
679+70.67	RT	78.26	11.8
679+73.20	LT	69.34	9.2

FILE NAME =	USER NAME = cushmanbw	DESIGNED -	REVISED -	<b>STATE OF ILLINOIS DEPARTMENT OF TRANSPORTATION</b>	<b>TREE REMOVAL SCHEDULE</b>	F.A.P. RTE.	SECTION	COUNTY	TOTAL SHEETS	SHEET NO.
cs\pwwork\PIWIDOT\CUSHMANBW\dms34123\dms34123.dgn	6486covr.dgn	DRAWN -	REVISED -			742	37R-3	OGLE	345	50
PLOT SCALE = 50.0000' / IN.	CHECKED -	REVISED -	CONTRACT NO. 84788			FED. ROAD DIST. NO. ILLINOIS FED. AID PROJECT				
PLOT DATE = Thu Apr 30 14:18:12 2009	DATE -	REVISED -	SCALE:			SHEET NO.	OF SHEETS	STA.	TO STA.	

# TREE REMOVAL SCHEDULE

20100210 TREE REMOVAL (OVER 15 UNITS DIAMETER)

679+83.14	RT	66.33	8.6
679+87.65	RT	60.09	7.7
679+89.78	RT	39.07	6.3
679+95.88	RT	71.85	9.1
679+98.32	RT	63.71	8.4
679+99.30	RT	62.74	8.8
679+99.83	RT	39.51	8.4
680+05.50	RT	44.11	9.1
680+14.58	RT	59.36	12.2
680+16.14	RT	43.45	9.3
680+32.55	LT	57.18	7.8
680+34.76	RT	53.41	10.2
680+36.68	RT	57.69	11.9
680+36.83	RT	57.53	11
680+77.99	RT	60.82	6
681+68.22	LT	37.26	6.6
682+50.45	LT	42.45	8.3
682+51.75	LT	41.94	6.9
682+87.38	LT	37.11	7
683+78.46	LT	34.50	6.2
683+86.17	LT	34.17	6

Margaret Fuller Rd.

17+87.09	LT	33.89	14
18+01.65	LT	34.55	12

Cartwright Lane

37+81.00	LT	36.40	14
37+87.76	LT	71.01	12
38+06.22	LT	35.80	12
38+35.05	RT	29.70	8
38+44.08	RT	37.30	6
38+78.21	RT	37.60	14.7

Access Rd. "A"

47+47.23	RT	17.57	10
47+50.12	RT	17.59	6
47+62.08	RT	26.98	8

TOTAL = 2364.6

STATION	LT/RT	OFFSET	UNIT
611+44.28	LT	45.56	25.2
611+76.14	LT	32.74	25
611+82.54	LT	31.31	19.7
612+83.09	LT	27.66	16
613+67.07	LT	38.11	26.7
614+01.19	LT	13.48	24
614+40.08	LT	33.47	21.9
614+56.19	LT	34.64	29.5
614+70.86	RT	28.95	17.2
615+40.72	LT	32.87	30.6
620+30.75	LT	16.93	16.5
622+80.09	LT	18.28	18.3
624+79.72	LT	17.87	23.2
626+58.69	LT	48.86	23.3
626+80.46	RT	33.73	19.2
628+02.00	LT	97.61	18
628+09.76	LT	123.42	20.9
628+31.50	LT	39.13	20.1
628+54.35	LT	38.54	16.4
628+78.54	LT	48.38	32.3
628+90.46	RT	41.89	16.2
629+28.86	LT	52.30	17
629+39.35	LT	68.60	18.8
630+11.83	LT	44.44	16.1
630+64.01	RT	47.93	16.4
630+97.78	LT	78.29	17.3
631+07.52	LT	113.79	17.7
631+17.32	LT	149.39	22.1
631+67.75	LT	62.61	19.5
632+10.24	LT	65.73	23.2
632+51.93	RT	42.22	21.8
632+54.51	LT	66.94	22.4
632+78.63	RT	35.29	23.1
634+49.21	RT	41.02	17
634+51.06	RT	39.70	19.4
641+70.98	LT	67.71	15.3
642+53.52	LT	100.51	15.6
642+92.90	LT	139.36	23.2
643+19.42	LT	90.93	22.4
643+50.34	LT	132.99	33.1
652+14.74	LT	43.58	16.2
654+86.14	LT	59.27	36.7
655+09.12	LT	57.84	27
657+47.96	RT	24.49	34
659+23.20	RT	62.79	19.8
663+10.44	LT	66.22	15.9
663+41.76	RT	15.99	30.7
663+94.99	RT	15.17	25.2
664+35.57	RT	14.40	31.2
664+87.49	RT	16.44	29.6
670+41.38	RT	93.40	22.2
672+95.95	RT	51.79	20.2
672+98.79	RT	55.10	24.3
673+25.53	LT	46.54	26.1
673+28.18	LT	44.26	27.5
673+48.91	RT	56.88	28.3
673+64.56	LT	41.31	16.3
673+66.37	RT	69.23	15.9
673+72.13	LT	42.24	26.5
673+73.43	RT	58.25	19.6
673+80.52	LT	49.67	16.9
673+81.84	RT	58.12	18.8
674+13.52	LT	44.11	36
674+16.69	RT	68.66	23
674+40.88	LT	41.14	29.2

674+60.61	RT	67.92	19
674+80.29	LT	42.52	19
674+98.69	LT	52.48	17.2
675+02.48	RT	54.73	16
675+23.21	LT	40.31	18.5
675+27.50	LT	38.34	35.1
675+33.27	LT	50.64	15.6
676+56.82	RT	85.05	15.4
676+67.05	RT	62.65	15.2
677+52.16	LT	78.33	19.1
677+76.60	LT	70.65	23.2
677+99.01	LT	54.47	25.2
678+12.86	LT	51.77	18.4
678+29.35	LT	63.69	24.5
678+53.06	LT	58.03	16.5
678+63.93	RT	25.42	30.3
678+75.25	RT	28.63	32.8
679+54.42	RT	29.78	21.7
679+57.69	LT	62.79	16.1
679+87.99	LT	55.75	19.6
680+08.51	LT	63.90	16.6
680+20.46	LT	53.54	21.1
680+61.97	LT	38.21	32.8
680+69.07	RT	50.77	20.4
683+39.68	RT	17.14	19
683+86.61	RT	27.37	16.7

Margaret Fuller Rd.

17+72.62	LT	33.28	32
18+51.17	LT	30.20	16

Blackhawk St.

28+54.59	RT	35.00	22.1
28+91.65	RT	34.90	17.7

Access Rd. "A"

47+88.53	RT	22.16	25
48+11.92	RT	22.84	22

TOTAL = 2138.5

# HORIZONTAL & VERTICAL CONTROL

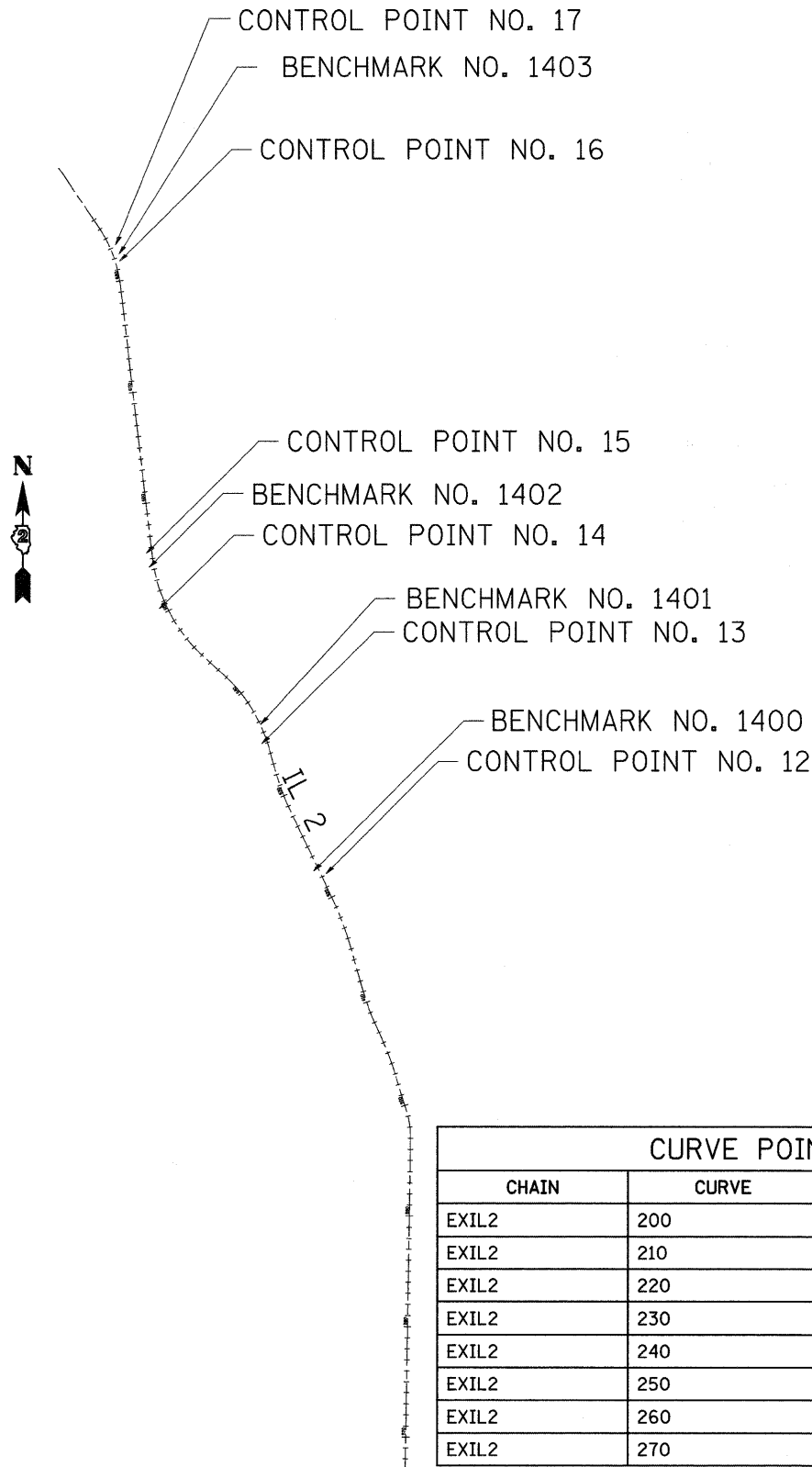

Chain EXIL2 contains:  
 60 CUR 200 CUR 210 CUR 220 CUR 230 CUR 240 CUR 250 CUR 260 CUR 270 CUR 280 CUR-  
 290 CUR 300 CUR 310 CUR 320 CUR 330 CUR 340 CUR 350 CUR 360 CUR 370 CUR 380 CU-  
 R 390 CUR 400 CUR 410 CUR 420 CUR 430 CUR 440 CUR 450 CUR 460 CUR 470 CUR 480 C-  
 UR 490 114

Beginning chain EXIL2 description  
 =====

Point 60 N 1,945,719.68 E 726,654.57 Sta 538+74.25

Course from 60 to PC 200 0° 53' 05.31" Dist 5,814.61'

Curve Data  
 -----

**Curve 200**  
 P.I. Station 598+16.73 N 1,951,661.45 E 726,746.33  
 Delta = 17° 45' 27.23" (LT)  
 Degree = 7° 00' 00.03"  
 Tangent = 127.86'  
 Length = 253.68'  
 Radius = 818.51'  
 External = 9.93'  
 Long Chord = 252.67'  
 Mid. Ord. = 9.81'  
 P.C. Station 596+88.86 N 1,951,533.60 E 726,744.36  
 P.T. Station 599+42.54 N 1,951,783.81 E 726,709.22  
 C.C. N 1,951,546.24 E 725,925.95

Course from PT 200 to PC 210 343° 07' 38.08" Dist 359.08'

Curve Data  
 -----

**Curve 210**  
 P.I. Station 604+39.28 N 1,952,259.16 E 726,565.04  
 Delta = 6° 52' 28.13" (LT)  
 Degree = 2° 30' 00.00"  
 Tangent = 137.65'  
 Length = 274.98'  
 Radius = 2,291.83'  
 External = 4.13'  
 Long Chord = 274.81'  
 Mid. Ord. = 4.12'  
 P.C. Station 603+01.62 N 1,952,127.43 E 726,605.00  
 P.T. Station 605+76.60 N 1,952,385.16 E 726,509.61  
 C.C. N 1,951,462.24 E 724,411.82

Course from PT 210 to PC 220 336° 15' 09.95" Dist 216.99'

Curve Data  
 -----

**Curve 220**  
 P.I. Station 609+49.15 N 1,952,726.17 E 726,359.58  
 Delta = 7° 45' 57.61" (RT)  
 Degree = 2° 30' 00.00"  
 Tangent = 155.56'  
 Length = 310.64'  
 Radius = 2,291.83'  
 External = 5.27'  
 Long Chord = 310.40'  
 Mid. Ord. = 5.26'  
 P.C. Station 607+93.60 N 1,952,583.78 E 726,422.22  
 P.T. Station 611+04.24 N 1,952,875.72 E 726,316.75  
 C.C. N 1,953,506.71 E 728,520.01

Course from PT 220 to PC 230 344° 01' 07.55" Dist 409.84'

Curve Data  
 -----

**Curve 230**  
 P.I. Station 617+60.09 N 1,953,506.22 E 726,136.18  
 Delta = 9° 48' 58.62" (LT)  
 Degree = 2° 00' 00.00"  
 Tangent = 246.01'  
 Length = 490.81'  
 Radius = 2,864.79'  
 External = 10.54'  
 Long Chord = 490.21'  
 Mid. Ord. = 10.50'  
 P.C. Station 615+14.08 N 1,953,269.72 E 726,203.91  
 P.T. Station 620+04.89 N 1,953,727.71 E 726,029.12  
 C.C. N 1,952,480.98 E 723,449.84

Course from PT 230 to PC 240 334° 12' 08.93" Dist 865.22'

Curve Data  
 -----

**Curve 240**  
 P.I. Station 630+51.33 N 1,954,669.86 E 725,573.72  
 Delta = 10° 14' 29.72" (RT)  
 Degree = 2° 49' 59.99"  
 Tangent = 181.22'  
 Length = 361.47'  
 Radius = 2,022.21'  
 External = 8.10'  
 Long Chord = 360.99'  
 Mid. Ord. = 8.07'  
 P.C. Station 628+70.11 N 1,954,506.70 E 725,652.59  
 P.T. Station 632+31.58 N 1,954,844.43 E 725,525.12  
 C.C. N 1,955,386.75 E 727,473.25

Course from PT 240 to PC 250 344° 26' 38.65" Dist 200.34'

Curve Data  
 -----

**Curve 250**  
 P.I. Station 638+41.48 N 1,955,431.99 E 725,361.56  
 Delta = 31° 54' 49.09" (LT)  
 Degree = 3° 59' 59.99"  
 Tangent = 409.56'  
 Length = 797.84'  
 Radius = 1,432.40'  
 External = 57.40'  
 Long Chord = 787.57'  
 Mid. Ord. = 55.19'  
 P.C. Station 634+31.31 N 1,955,037.43 E 725,471.40  
 P.T. Station 642+29.75 N 1,955,708.85 E 725,059.74  
 C.C. N 1,954,653.29 E 724,091.47

Course from PT 250 to PC 260 312° 31' 49.56" Dist 258.24'

Curve Data  
 -----

**Curve 260**  
 P.I. Station 650+19.25 N 1,956,242.54 E 724,477.95  
 Delta = 40° 41' 54.26" (RT)  
 Degree = 3° 59' 59.99"  
 Tangent = 531.26'  
 Length = 1,017.46'  
 Radius = 1,432.40'  
 External = 95.35'  
 Long Chord = 996.20'  
 Mid. Ord. = 89.39'  
 P.C. Station 644+88.00 N 1,955,883.42 E 724,869.44  
 P.T. Station 655+05.46 N 1,956,770.09 E 724,415.31  
 C.C. N 1,956,938.98 E 725,837.71

Course from PT 260 to PC 270 353° 13' 43.82" Dist 2,440.91'

Curve Data  
 -----

**Curve 270**  
 P.I. Station 682+46.40 N 1,959,491.92 E 724,092.14  
 Delta = 27° 27' 51.62" (LT)  
 Degree = 4° 40' 00.00"  
 Tangent = 300.03'  
 Length = 588.52'  
 Radius = 1,227.77'  
 External = 36.13'  
 Long Chord = 582.90'  
 Mid. Ord. = 35.09'  
 P.C. Station 679+46.37 N 1,959,193.98 E 724,127.52  
 P.T. Station 685+34.89 N 1,959,739.96 E 723,923.35  
 C.C. N 1,959,049.22 E 722,908.31

Course from PT 270 to PC 280 325° 45' 52.20" Dist 626.27'

CURVE POINT NUMBERS					
CHAIN	CURVE	PI	CC	PC	PT
EXIL2	200	200	201	202	203
EXIL2	210	210	211	212	213
EXIL2	220	220	221	222	223
EXIL2	230	230	231	232	233
EXIL2	240	240	241	242	243
EXIL2	250	250	251	252	253
EXIL2	260	260	261	262	263
EXIL2	270	270	271	272	273

FILE NAME =	USER NAME = cushmanbw	DESIGNED -	REVISED -	<b>STATE OF ILLINOIS DEPARTMENT OF TRANSPORTATION</b>	<b>HORIZONTAL &amp; VERTICAL CONTROL</b>	F.A.P RTE.	SECTION	COUNTY	TOTAL SHEETS	SHEET NO.	
ci:\pwwork\pwwid\DOT\CUSHMANBW\dms34123\dms34123v04486hvc.dgn		DRAWN -	REVISED -			742	3TR-3	OGLE	345	52	
PLOT SCALE = 50.0000' / IN.		CHECKED -	REVISED -			CONTRACT NO. 84788					
PLOT DATE = Thu Apr 30 15:31:44 2009		DATE -	REVISED -			FED. ROAD DIST. NO. [ILLINOIS] FED. AID PROJECT					

# HORIZONTAL & VERTICAL CONTROL

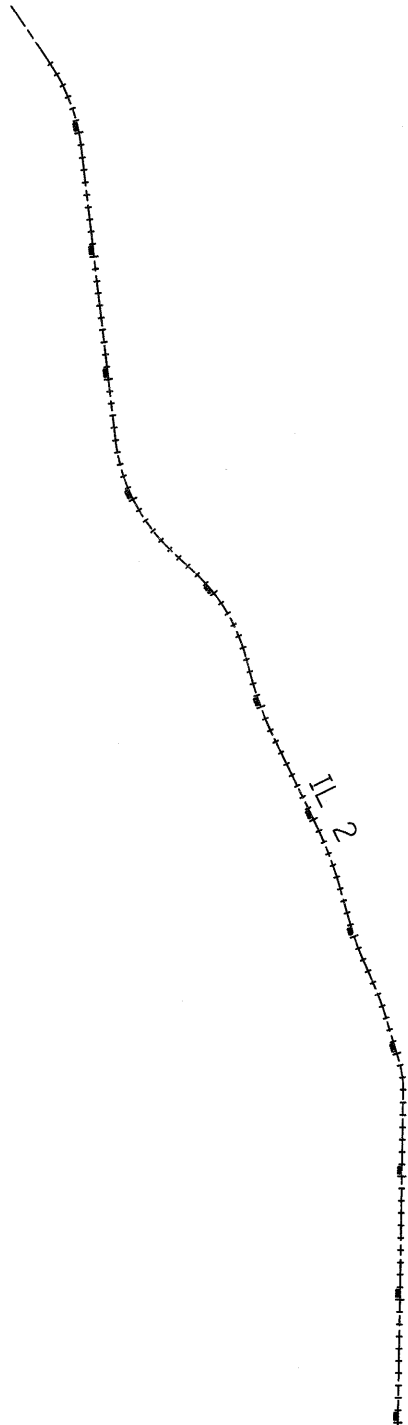

Chain PRIL2D contains:  
 70000 CUR 70200 CUR 70210 CUR 60210 CUR 60220 100001 CUR 70240 CUR 70250 CUR 7-  
 0260 CUR 70270 CUR 70280 CUR 70290 CUR 70300 CUR 70310 CUR 70320 CUR 70330 CUR -  
 70340 CUR 70350 CUR 70360 CUR 70370 CUR 71300 CUR 71310 CUR 50200 CUR 50210 CUR-  
 71200 CUR 71210 CUR 71220 CUR 72300 CUR 72310 CUR 72320 CUR 72330 CUR 72340 CU-  
 R 71280 CUR 71290 70005

Beginning chain PRIL2D description  
 =====

Point 70000 N 1,945,719.68 E 726,654.57 Sta 538+74.25  
 Course from 70000 to PC 70200 0° 53' 05.40" Dist 5,814.61'

Point 100001 N 1,953,730.20 E 726,014.60 Sta 620+12.36  
 Course from 100001 to PC 70240 334° 12' 08.86" Dist 747.43'

Curve Data  
 -----  
 Curve 70200  
 P.I. Station 598+16.73 N 1,951,661.45 E 726,746.33  
 Delta = 17° 45' 27.34" (LT)  
 Degree = 7° 00' 00.03"  
 Tangent = 127.86'  
 Length = 253.68'  
 Radius = 818.51'  
 External = 9.93'  
 Long Chord = 252.67'  
 Mid. Ord. = 9.81'  
 P.C. Station 596+88.86 N 1,951,533.60 E 726,744.36  
 P.T. Station 599+42.54 N 1,951,783.81 E 726,709.22  
 C.C. N 1,951,546.24 E 725,925.95

Curve Data  
 -----  
 Curve 70240  
 P.I. Station 629+83.82 N 1,954,604.83 E 725,591.83  
 Delta = 10° 14' 28.79" (RT)  
 Degree = 2° 17' 30.59"  
 Tangent = 224.03'  
 Length = 446.86'  
 Radius = 2,500.00'  
 External = 10.02'  
 Long Chord = 446.27'  
 Mid. Ord. = 9.98'  
 P.C. Station 627+59.79 N 1,954,403.13 E 725,689.32  
 P.T. Station 632+06.65 N 1,954,820.65 E 725,531.75  
 C.C. N 1,955,491.11 E 727,940.17

Course from PT 70200 to PC 70210 343° 07' 38.06" Dist 359.10'

Course from PT 70240 to PC 70250 344° 26' 37.65" Dist 225.03'

Curve Data  
 -----  
 Curve 70210  
 P.I. Station 604+39.30 N 1,952,259.18 E 726,565.04  
 Delta = 6° 52' 29.31" (LT)  
 Degree = 2° 30' 00.00"  
 Tangent = 137.66'  
 Length = 274.99'  
 Radius = 2,291.83'  
 External = 4.13'  
 Long Chord = 274.83'  
 Mid. Ord. = 4.12'  
 P.C. Station 603+01.64 N 1,952,127.45 E 726,605.00  
 P.T. Station 605+76.63 N 1,952,385.19 E 726,509.60  
 C.C. N 1,951,462.25 E 724,411.82

Curve Data  
 -----  
 Curve 70250  
 P.I. Station 638+41.23 N 1,955,431.99 E 725,361.56  
 Delta = 31° 54' 45.88" (LT)  
 Degree = 3° 59' 59.99"  
 Tangent = 409.55'  
 Length = 797.82'  
 Radius = 1,432.40'  
 External = 57.40'  
 Long Chord = 787.55'  
 Mid. Ord. = 55.19'  
 P.C. Station 634+31.68 N 1,955,037.44 E 725,471.40  
 P.T. Station 642+29.50 N 1,955,708.84 E 725,059.76  
 C.C. N 1,954,653.29 E 724,091.47

Course from PT 70210 to PC 60210 336° 15' 08.75" Dist 207.21'

Course from PT 70250 to PC 70260 312° 31' 51.78" Dist 246.01'

Curve Data  
 -----  
 Curve 60210  
 P.I. Station 609+61.74 N 1,952,737.69 E 726,354.52  
 Delta = 6° 47' 14.35" (RT)  
 Degree = 1° 54' 35.49"  
 Tangent = 177.90'  
 Length = 355.38'  
 Radius = 3,000.00'  
 External = 5.27'  
 Long Chord = 355.18'  
 Mid. Ord. = 5.26'  
 P.C. Station 607+83.84 N 1,952,574.85 E 726,426.16  
 P.T. Station 611+39.22 N 1,952,907.85 E 726,302.62  
 C.C. N 1,953,782.98 E 729,172.14

Curve Data  
 -----  
 Curve 70260  
 P.I. Station 650+08.08 N 1,956,235.15 E 724,486.01  
 Delta = 40° 47' 28.59" (RT)  
 Degree = 4° 00' 00.05"  
 Tangent = 532.58'  
 Length = 1,019.78'  
 Radius = 1,432.39'  
 External = 95.80'  
 Long Chord = 998.38'  
 Mid. Ord. = 89.80'  
 P.C. Station 644+75.50 N 1,955,875.14 E 724,878.47  
 P.T. Station 654+95.28 N 1,956,764.12 E 724,424.08  
 C.C. N 1,956,930.68 E 725,846.75

Course from PT 60210 to PC 60220 343° 02' 23.09" Dist 409.71'

Course from PT 70260 to PC 70270 353° 19' 20.37" Dist 2,382.05'

Curve Data  
 -----  
 Curve 60220  
 P.I. Station 617+80.75 N 1,953,521.48 E 726,115.48  
 Delta = 8° 50' 14.23" (LT)  
 Degree = 1° 54' 35.49"  
 Tangent = 231.82'  
 Length = 462.72'  
 Radius = 3,000.00'  
 External = 8.94'  
 Long Chord = 462.26'  
 Mid. Ord. = 8.92'  
 P.C. Station 615+48.93 N 1,953,299.74 E 726,183.11  
 P.T. Station 620+11.65 N 1,953,730.20 E 726,014.60  
 C.C. N 1,952,424.62 E 723,313.58

Curve Data  
 -----  
 Curve 70270  
 P.I. Station 682+45.19 N 1,959,495.37 E 724,104.31  
 Delta = 27° 33' 30.48" (LT)  
 Degree = 3° 49' 10.99"  
 Tangent = 367.86'  
 Length = 721.48'  
 Radius = 1,500.00'  
 External = 44.45'  
 Long Chord = 714.54'  
 Mid. Ord. = 43.17'  
 P.C. Station 678+77.33 N 1,959,130.00 E 724,147.09  
 P.T. Station 685+98.81 N 1,959,799.49 E 723,897.35  
 C.C. N 1,958,955.58 E 722,657.26

Equation: Sta 620+11.65 (BK) = Sta 620+12.36 (AH) -----  
 End Region 1  
 Begin Region 2

Course from PT 70270 to PC 70280 325° 45' 49.89" Dist 562.63'

CURVE POINT NUMBERS					
CHAIN	CURVE	PI	CC	PC	PT
PRIL2D	70200	70200	70201	70202	70203
PRIL2D	70210	70210	70211	70212	70213
PRIL2D	60210	60210	60211	60212	60213
PRIL2D	60220	60220	60221	60222	60223
PRIL2D	70240	70240	70241	70242	70243
PRIL2D	70250	70250	70251	70252	70253
PRIL2D	70260	70260	70261	70262	70263
PRIL2D	70270	70270	70271	70272	70273

# HORIZONTAL & VERTICAL CONTROL

## FAIR ST.

Chain FAIR contains:  
15450000 15450200

Beginning chain FAIR description  
=====

Point 15450000 N 1,952,173.7340 E 726,448.9950 Sta 248+57.7177  
Course from 15450000 to 15450200 91° 01' 51.1146" Dist 142.2823'  
Point 15450200 N 1,952,171.1742 E 726,591.2543 Sta 250+00.0000  
=====

Ending chain FAIR description

Chain PFAIR contains:  
15450000 15450200

Beginning chain PFAIR description  
=====

Point 15450000 N 1,952,173.7340 E 726,448.9950 Sta 248+57.7177  
Course from 15450000 to 15450200 91° 01' 51.1146" Dist 142.2823'  
Point 15450200 N 1,952,171.1742 E 726,591.2543 Sta 250+00.0000  
=====

Ending chain PFAIR description

## BLACKHAWK ST.

Chain EBLKHWK contains:  
64 66

Beginning chain EBLKHWK description  
=====

Point 64 N 1,954,728.1740 E 725,561.2910 Sta 20+00.0000  
Course from 64 to 66 268° 43' 26.5480" Dist 673.2129'  
Point 66 N 1,954,713.1830 E 724,888.2450 Sta 26+73.2130  
=====

Ending chain EBLKHWK description

Chain PBLKHWK contains:  
70007 50102

Beginning chain PBLKHWK description  
=====

Point 70007 N 1,954,713.1830 E 724,888.2450 Sta 23+28.6402  
Course from 70007 to 50102 88° 43' 26.4356" Dist 671.3598'  
Point 50102 N 1,954,728.1331 E 725,559.4383 Sta 30+00.0000  
=====

Ending chain PBLKHWK description

## ACCESS RD. A

Chain ACCESRDA contains:  
70009 CUR 71340 51000

Beginning chain ACCESRDA description  
=====

Point 70009 N 1,955,671.9863 E 724,780.8678 Sta 47+25.6985  
Course from 70009 to PC 71340 88° 38' 39.7493" Dist 86.8968'

Curve Data  
-----\*

Curve 71340  
P.I. Station 48+55.0596 N 1,955,675.0467 E 724,910.1927  
Delta = 16° 06' 47.3747" (LT)  
Degree = 19° 05' 54.9354"  
Tangent = 42.4644'  
Length = 84.3683'  
Radius = 300.0000'  
External = 2.9905'  
Long Chord = 84.0906'  
Mid. Ord. = 2.9610'  
P.C. Station 48+12.5953 N 1,955,674.0421 E 724,867.7402  
P.T. Station 48+96.9636 N 1,955,687.7939 E 724,950.6987  
C.C. N 1,955,973.9581 E 724,860.6429

Course from PT 71340 to 51000 72° 31' 52.3746" Dist 103.0364'

Point 51000 N 1,955,718.7241 E 725,048.9832 Sta 50+00.0000  
=====

Ending chain ACCESRDA description

## MARGARET FULLER

Chain EMARGFUL contains:  
63 61

Beginning chain EMARGFUL description  
=====

Point 63 N 1,954,370.3330 E 725,718.5000 Sta 10+00.0000  
Course from 63 to 61 268° 43' 07.5770" Dist 763.1108'  
Point 61 N 1,954,353.2700 E 724,955.5800 Sta 17+63.1108  
=====

Ending chain EMARGFUL description

Chain PMARGFUL contains:  
70006 50101

Beginning chain PMARGFUL description  
=====

Point 70006 N 1,954,353.2700 E 724,955.5800 Sta 12+50.0745  
Course from 70006 to 50101 88° 43' 07.6264" Dist 749.9255'  
Point 50101 N 1,954,370.0380 E 725,705.3180 Sta 20+00.0000  
=====

Ending chain PMARGFUL description

## CARTWRIGHT ST.

Chain ECRTWRT contains:  
67 69

Beginning chain ECRTWRT description  
=====

Point 67 N 1,955,084.8290 E 725,457.1920 Sta 30+00.0000  
Course from 67 to 69 268° 53' 34.4914" Dist 683.7606'  
Point 69 N 1,955,071.6180 E 724,773.5590 Sta 36+83.7606  
=====

Ending chain ECRTWRT description

Chain PCRTWRT contains:  
70008 50103

Beginning chain PCRTWRT description  
=====

Point 70008 N 1,955,071.6180 E 724,773.5590 Sta 33+16.1131  
Course from 70008 to 50103 88° 53' 34.5935" Dist 683.8869'  
Point 50103 N 1,955,084.8311 E 725,457.3182 Sta 40+00.0000  
=====

Ending chain PCRTWRT description

## ACCESS RD. B

Chain ACCESRDB contains:  
70004 CUR 71350 70010

Beginning chain ACCESRDB description  
=====

Point 70004 N 1,955,718.7241 E 725,048.9832 Sta 50+00.0000  
Course from 70004 to PC 71350 27° 31' 49.0434" Dist 39.5023'

Curve Data  
-----\*

Curve 71350  
P.I. Station 51+64.6891 N 1,955,864.7646 E 725,125.1057  
Delta = 34° 45' 24.4465" (LT)  
Degree = 14° 19' 26.2016"  
Tangent = 125.1868'  
Length = 242.6482'  
Radius = 400.0000'  
External = 19.1321'  
Long Chord = 238.9448'  
Mid. Ord. = 18.2588'  
P.C. Station 50+39.5023 N 1,955,753.7534 E 725,067.2418  
P.T. Station 52+82.1505 N 1,955,988.9571 E 725,109.3586  
C.C. N 1,955,938.6415 E 724,712.5358

Course from PT 71350 to 70010 352° 46' 25.2790" Dist 66.1898'

Point 70010 N 1,956,054.6212 E 725,101.0327 Sta 53+48.3403  
=====

Ending chain ACCESRDB description

FILE NAME =	USER NAME = cushmanbw	DESIGNED -	REVISED -	<b>STATE OF ILLINOIS DEPARTMENT OF TRANSPORTATION</b>	<b>HORIZONTAL &amp; VERTICAL CONTROL</b>	F.A.P RTE. 742	SECTION 37R-3	COUNTY OGLE	TOTAL SHEETS 345	SHEET NO. 54		
ct:\pw_work\VPWIDOT\CUSHMANBW\dms34123\dms34123.dgn	0486hvac.dgn	DRAWN -	REVISED -			SCALE:	SHEET NO. OF SHEETS	STA. TO STA.	CONTRACT NO. 84788			
PLOT SCALE = 50.0000' / IN.	CHECKED -	REVISED -	REVISED -									
PLOT DATE = Thu Apr 30 15:31:46 2009	DATE -	REVISED -	REVISED -			FED. ROAD DIST. NO. ILLINOIS FED. AID PROJECT						

# HORIZONTAL & VERTICAL CONTROL

## CULTRA DR.

Chain PCULTRA contains:  
71360 70011

Beginning chain PCULTRA description  
=====

Point 71360 N 1,957,470.0588 E 724,341.4317 Sta 60+00.0000

Course from 71360 to 70011 79° 40' 51.0440" Dist 286.6897'

Point 70011 N 1,957,521.4138 E 724,623.4843 Sta 62+86.6897

=====

Ending chain PCULTRA description

## STRONGHOLD

Chain STRGHOLD contains:  
70013 CUR 72430 72420

Beginning chain STRGHOLD description  
=====

Point 70013 N 1,958,826.9890 E 723,766.1260 Sta 65+82.4262

Course from 70013 to PC 72430 71° 44' 48.5049" Dist 145.7796'

Curve Data  
\*-----\*

Curve 72430

P.I. Station 67+70.3781 N 1,958,885.8587 E 723,944.6205

Delta = 16° 00' 13.5457" (RT)

Degree = 19° 05' 54.9354"

Tangent = 42.1723'

Length = 83.7955'

Radius = 300.0000'

External = 2.9497'

Long Chord = 83.5234'

Mid. Ord. = 2.9210'

P.C. Station 67+28.2058 N 1,958,872.6496 E 723,904.5702

P.T. Station 68+12.0013 N 1,958,887.5139 E 723,986.7603

C.C. N 1,958,587.7451 E 723,998.5353

Course from PT 72430 to 72420 87° 45' 02.0506" Dist 187.9987'

Point 72420 N 1,958,894.8929 E 724,174.6141 Sta 70+00.0000

=====

Ending chain STRGHOLD description

## BOATRAMP

Chain PBTRAMP contains:  
72400 CUR 72400 72401

Beginning chain PBTRAMP description  
=====

Point 72400 N 1,958,894.8911 E 724,174.6152 Sta 70+00.0000

Course from 72400 to PC 72400 83° 19' 21.0288" Dist 148.9420'

Curve Data  
\*-----\*

Curve 72400

P.I. Station 71+67.0962 N 1,958,914.3220 E 724,340.5778

Delta = 39° 54' 18.6820" (LT)

Degree = 114° 34' 32.5111"

Tangent = 18.1542'

Length = 34.8287'

Radius = 50.0069'

External = 3.1933'

Long Chord = 34.1290'

Mid. Ord. = 3.0017'

P.C. Station 71+48.9420 N 1,958,912.2101 E 724,322.5468

P.T. Station 71+83.7706 N 1,958,927.5092 E 724,353.0546

C.C. N 1,958,961.8775 E 724,316.7295

Course from PT 72400 to 72401 43° 24' 51.9811" Dist 133.1086'

Point 72401 N 1,959,024.1995 E 724,444.5362 Sta 73+16.8792

=====

Ending chain PBTRAMP description

FILE NAME =	USER NAME = cushmanbw	DESIGNED -	REVISED -	<b>STATE OF ILLINOIS DEPARTMENT OF TRANSPORTATION</b>	<b>HORIZONTAL &amp; VERTICAL CONTROL</b>	F.A.P. RTE.	SECTION	COUNTY	TOTAL SHEETS	SHEET NO.	
ct:\pw_work\VP\WIDOT\CUSHMANBW\dms34123\dms34123.dwg	6486hvc.dgn	DRAWN -	REVISED -			742	37R-3	OGLE	345	55	
PLOT SCALE = 50.0000' / IN.	CHECKED -	REVISED -	REVISED -			SCALE: SHEET NO. OF SHEETS STA. TO STA.		CONTRACT NO. 84788			
PLOT DATE = Thu Apr 30 15:31:46 2009	DATE -	REVISED -	REVISED -			FED. ROAD DIST. NO. ILLINOIS FED. AID PROJECT					



# HORIZONTAL & VERTICAL CONTROL

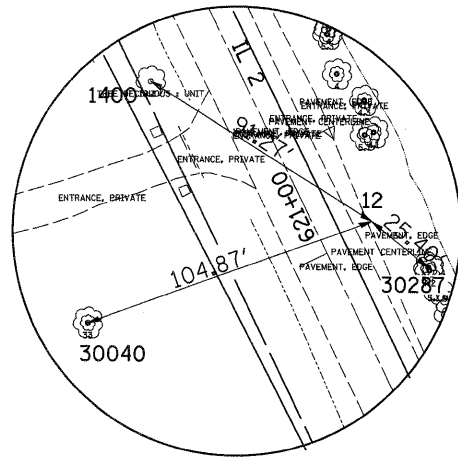

HORIZONTAL CONTROL POINT NO. 12

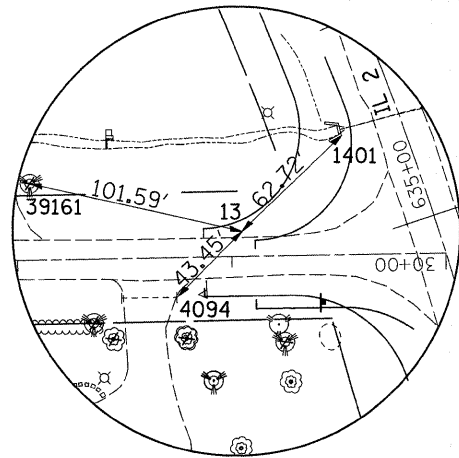

HORIZONTAL CONTROL POINT NO. 13

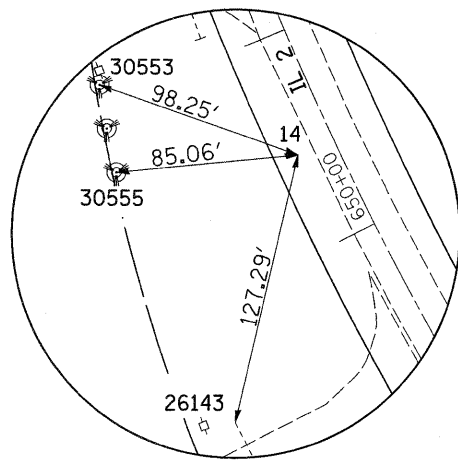

HORIZONTAL CONTROL POINT NO. 14

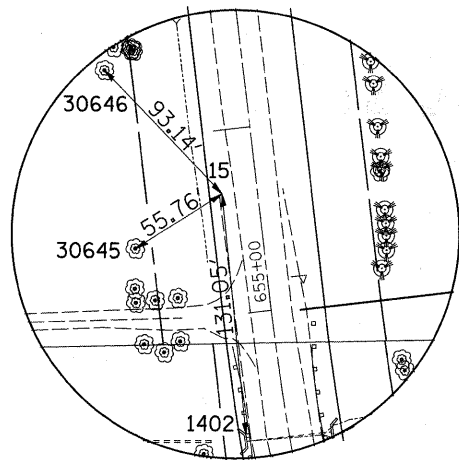

HORIZONTAL CONTROL POINT NO. 15

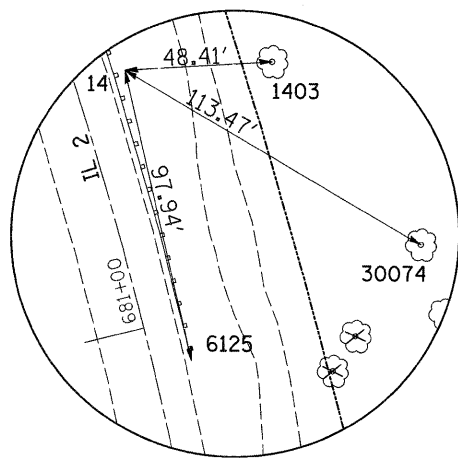

HORIZONTAL CONTROL POINT NO. 16

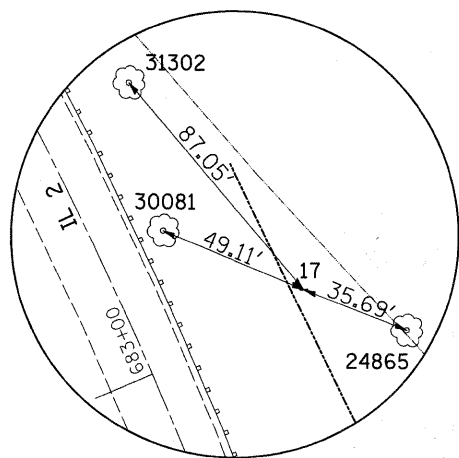

HORIZONTAL CONTROL POINT NO. 17

REFERENCE TIES				
POINT	CHAIN	STATION	OFFSET	DESCRIPTION
1400	EXIL2	622+80.74	29.25' LT	TREE DECIDUOUS
1401	EXIL2	635+49.93	28.32' LT	CROSS-CUT IN HEADWALL
1402	EXIL2	654+35.63	23.28' LT	CROSS-CUT IN HEADWALL
1403	EXIL2	681+71.11	64.04' RT	RAILROAD SPIKE IN TREE
4094	EXIL2	679+33.49	10.36' RT	CULVERT PIPE
6125	EXIL2	680+86.12	12.70' RT	GUARDRAIL STEEL PLATE BEAM
24865	EXIL2	682+81.95	80.97' RT	TREE DECIDUOUS
26143	EXIL2	649+50.69	100.48' LT	PIPE CULVERT
30040	EXIL2	622+14.57	85.44' LT	TREE DECIDUOUS
30074	EXIL2	681+04.64	95.92' RT	TREE DECIDUOUS
30081	EXIL2	683+40.63	22.17' RT	TREE DECIDUOUS
30287	EXIL2	621+80.09	29.44' RT	TREE DECIDUOUS
30553	EXIL2	651+09.10	89.49' LT	TREE EVERGREEN
30555	EXIL2	650+70.86	98.49' LT	TREE EVERGREEN
30645	EXIL2	655+41.74	69.72' LT	TREE DECIDUOUS
30646	EXIL2	656+40.02	75.19' LT	TREE DECIDUOUS
31302	EXIL2	683+87.02	33.25' RT	TREE DECIDUOUS
39161	EXIL2	655+15.37	11.16' LT	TREE EVERGREEN

BENCH MARKS							
POINT	NORTH	EAST	ELEVATION	CHAIN	STATION	OFFSET	DESCRIPTION
1400	1953963.3400	725882.7390	683.8990	EXIL2	622+80.74	29.25' LT	TREE DECIDUOUS
1401	1955139.8830	725408.5390	680.1680	EXIL2	635+49.93	28.32' RT	CROSS-CUT IN HEADWALL
1402	1956697.1100	724402.2780	694.4350	EXIL2	654+35.63	23.28' LT	CROSS-CUT IN HEADWALL
1403	1959432.4910	724141.9480	675.7380	EXIL2	681+71.11	64.04' RT	RAILROAD SPIKE IN TREE

HORIZONTAL CONTROL POINTS							
POINT	NORTH	EAST	ELEVATION	CHAIN	STATION	OFFSET	DESCRIPTION
12	1953914.4200	725959.7800	682.2350	EXIL2	622+03.17	18.8241' RT	PHOTO CONTROL HORIZONTAL
13	1955094.8430	725362.0540	683.1500	EXIL2	635+22.10	87.2755' LT	PHOTO CONTROL HORIZONTAL
14	1956320.6500	724525.5390	693.9250	EXIL2	650+43.96	18.1669' LT	PHOTO CONTROL HORIZONTAL
15	1956827.4930	724389.0840	693.8700	EXIL2	655+65.5502	19.2747' LT	PHOTO CONTROL HORIZONTAL
16	1959429.8950	724093.6280	679.1100	EXIL2	681+82.8071	17.1772' RT	PHOTO CONTROL HORIZONTAL
17	1959561.9550	724084.9170	674.2050	EXIL2	683+05.8388	55.7028' RT	PHOTO CONTROL HORIZONTAL

SURVEY WORK POINTS							
POINT	NORTH	EAST	ELEVATION	CHAIN	STATION	OFFSET	DESCRIPTION
1114	1962977.7160	722352.7270	687.5664	EXIL2	722+00.88	28.5631' LT	TRAVERSE STATION
1116	1963393.5480	722555.1440	682.8425	EXIL2	726+58.77	34.4271' RT	TRAVERSE STATION
1121	1966155.8520	724055.1670	691.2700	EXIL2	758+33.93	20.613' RT	PAVEMENT
1104	1957190.0100	724341.8320	691.2470	EXIL2	659+31.11	23.4548' LT	TRAVERSE STATION
1106	1958304.0680	724258.3170	687.2190	EXIL2	670+47.24	24.9648' RT	TRAVERSE STATION

FILE NAME =	USER NAME = cushmanbw	DESIGNED -	REVISED -
ct:\pw_work\VP\IDOT\CUSHMANBW\dms34123\d6486hvc.dgn		DRAWN -	REVISED -
		CHECKED -	REVISED -
		DATE -	REVISED -

STATE OF ILLINOIS  
DEPARTMENT OF TRANSPORTATION

## HORIZONTAL & VERTICAL CONTROL

SCALE: SHEET NO. OF SHEETS STA. TO STA.

F.A.P. RTE. 742	SECTION 37R-3	COUNTY OGLE	TOTAL SHEETS 345	SHEET NO. 56
CONTRACT NO. 84788				
FED. ROAD DIST. NO. [ILLINOIS] FED. AID PROJECT				



PLAN	SURVEYED	DATE
	PLOTTED	
	NOTES CHECKED	
	NO. OF WAY CHECKED	
	CADD FILE NAME	

PROFILE	SURVEYED	DATE
	PLOTTED	
	NOTES CHECKED	
	NO. OF WAY CHECKED	
	STRUCTURE NOTATIONS CHECKED	

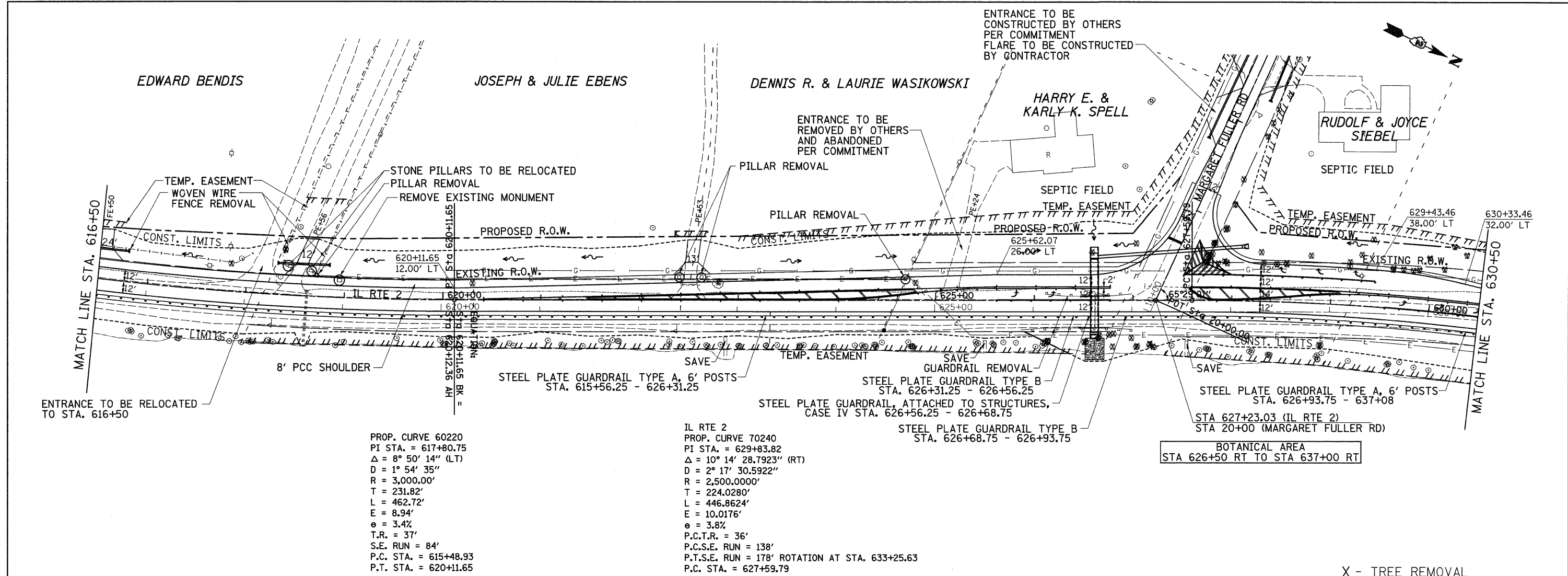

PROP. CURVE 60220  
 PI STA. = 617+80.75  
 $\Delta = 8^\circ 50' 14''$  (LT)  
 $D = 1^\circ 54' 35''$   
 $R = 3,000.00'$   
 $T = 231.82'$   
 $L = 462.72'$   
 $E = 8.94'$   
 $e = 3.4\%$   
 $T.R. = 37'$   
 $S.E. RUN = 84'$   
 $P.C. STA. = 615+48.93$   
 $P.T. STA. = 620+11.65$

IL RTE 2  
 PROP. CURVE 70240  
 PI STA. = 629+83.82  
 $\Delta = 10^\circ 14' 28.7923''$  (RT)  
 $D = 2^\circ 17' 30.5922''$   
 $R = 2,500.0000'$   
 $T = 224.0280'$   
 $L = 446.8624'$   
 $E = 10.0176'$   
 $e = 3.8\%$   
 $P.C.T.R. = 36'$   
 $P.C.S.E. RUN = 138'$   
 $P.T.S.E. RUN = 178'$  ROTATION AT STA. 633+25.63  
 $P.C. STA. = 627+59.79$   
 $P.T. STA. = 632+06.65$

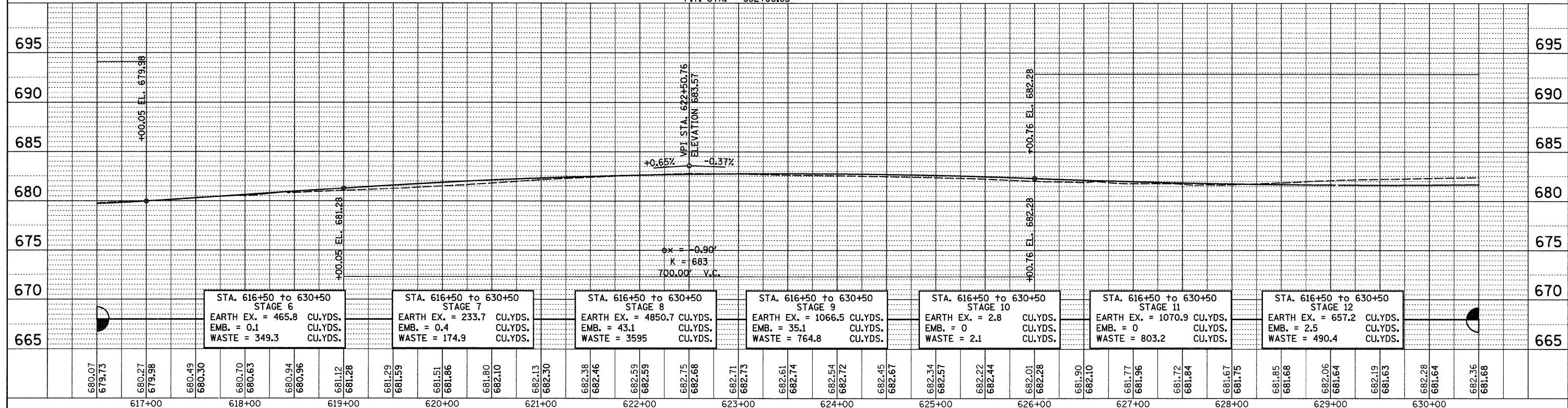

STATION	STAGE	EARTH EX. CU.YDS.	EMB. CU.YDS.	WASTE CU.YDS.
STA. 616+50 to 630+50	STAGE 6	465.8	0.1	349.3
STA. 616+50 to 630+50	STAGE 7	233.7	0.4	174.9
STA. 616+50 to 630+50	STAGE 8	4850.7	43.1	3595
STA. 616+50 to 630+50	STAGE 9	1066.5	35.1	764.8
STA. 616+50 to 630+50	STAGE 10	2.8	0	2.1
STA. 616+50 to 630+50	STAGE 11	1070.9	0	803.2
STA. 616+50 to 630+50	STAGE 12	657.2	2.5	490.4

FILE NAME =	USER NAME = cushmanbw	DESIGNED -	REVISED -	STATE OF ILLINOIS DEPARTMENT OF TRANSPORTATION		PLAN & PROFILE		F.A.P. RTE. 742	SECTION 37R-3	COUNTY OGLE	TOTAL SHEETS 345	SHEET NO. 58
ca:\pwwork\KFWIDOT\CUSHMANBW\dms34123\d06186p1n.Ldgn		DRAWN -	REVISED -			SCALE:					CONTRACT NO. 84788	
PLOT SCALE = 50.0000' / IN.		CHECKED -	REVISED -			SHEET NO. OF SHEETS STA. TO STA.		FED. ROAD DIST. NO. ILLINOIS FED. AID PROJECT				
PLOT DATE = Thu Apr 30 15:38:43 2009		DATE -	REVISED -									

PLAN	SURVEYED	DATE
	PLOTTED	
	CHECKED	
	BY	
	NO.	
	DATE	

PROFILE	SURVEYED	DATE
	PLOTTED	
	CHECKED	
	BY	
	NO.	
	DATE	

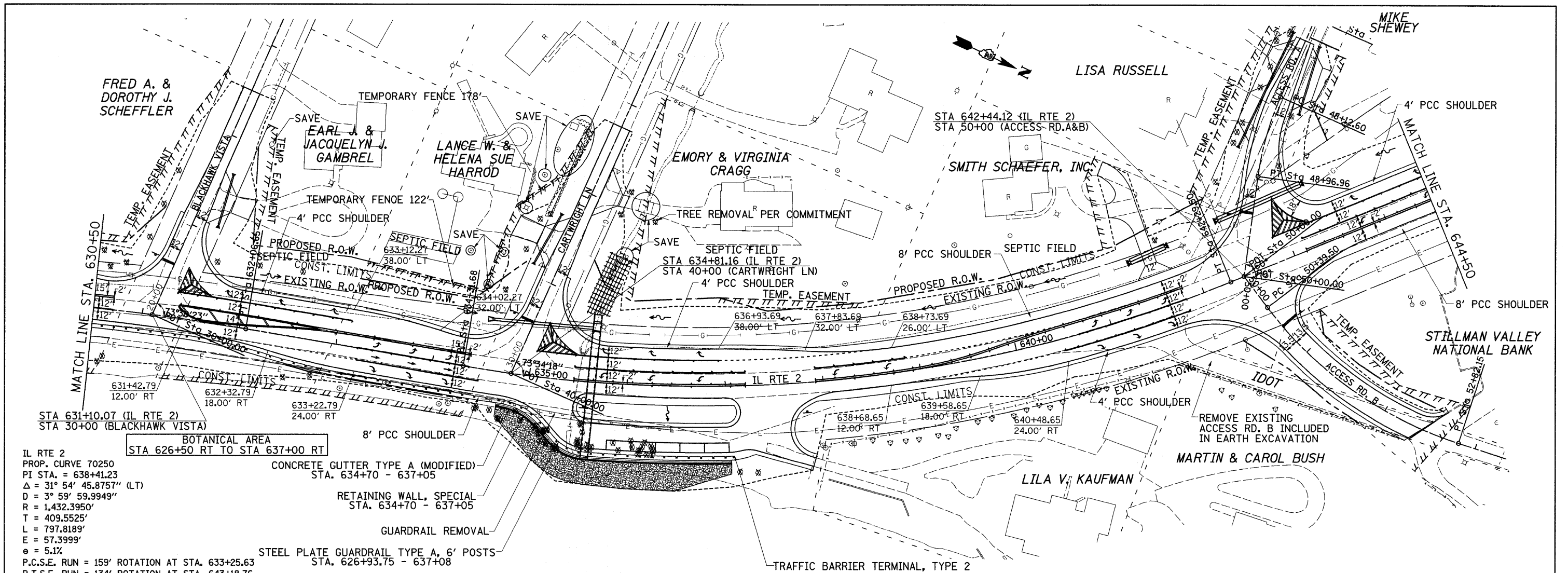

IL RTE 2  
 PROP. CURVE 70250  
 PI STA. = 638+41.23  
 $\Delta = 31^\circ 54' 45.8757''$  (LT)  
 $D = 3^\circ 59' 59.9949''$   
 $R = 1,432.3950'$   
 $T = 409.5525'$   
 $L = 797.8189'$   
 $E = 57.3999'$   
 $e = 5.1\%$   
 P.C.S.E. RUN = 159' ROTATION AT STA. 633+25.63  
 P.T.S.E. RUN = 134' ROTATION AT STA. 643+18.76  
 P.C. STA. = 634+31.68  
 P.T. STA. = 642+29.50

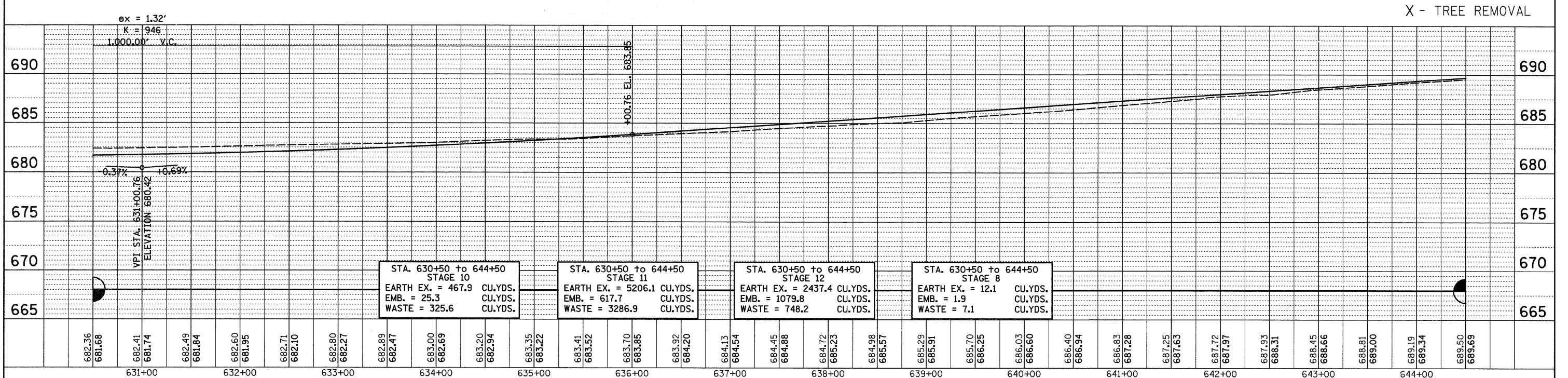

FILE NAME =	USER NAME = cushmanbw	DESIGNED -	REVISED -	STATE OF ILLINOIS DEPARTMENT OF TRANSPORTATION		PLAN & PROFILE		F.A.P. RTE. 742	SECTION 37R-3	COUNTY OGLE	TOTAL SHEETS 345	SHEET NO. 59
CONTRACT NO. 84788	SCALE:	SHEET NO. OF SHEETS	STA. TO STA.	FED. ROAD DIST. NO. (ILLINOIS) FED. AID PROJECT								

PLAN	SURVEYED	DATE
	PLOTTED	
	CHECKED	
	BY	
	NO. OF MAY CHECKED	
	CADD FILE NAME	
	NO.	

PROFILE	SURVEYED	DATE
	PLOTTED	
	CHECKED	
	BY	
	NO. OF MAY CHECKED	
	STRUCTURE NOTATIONS CHKD	
	NO.	

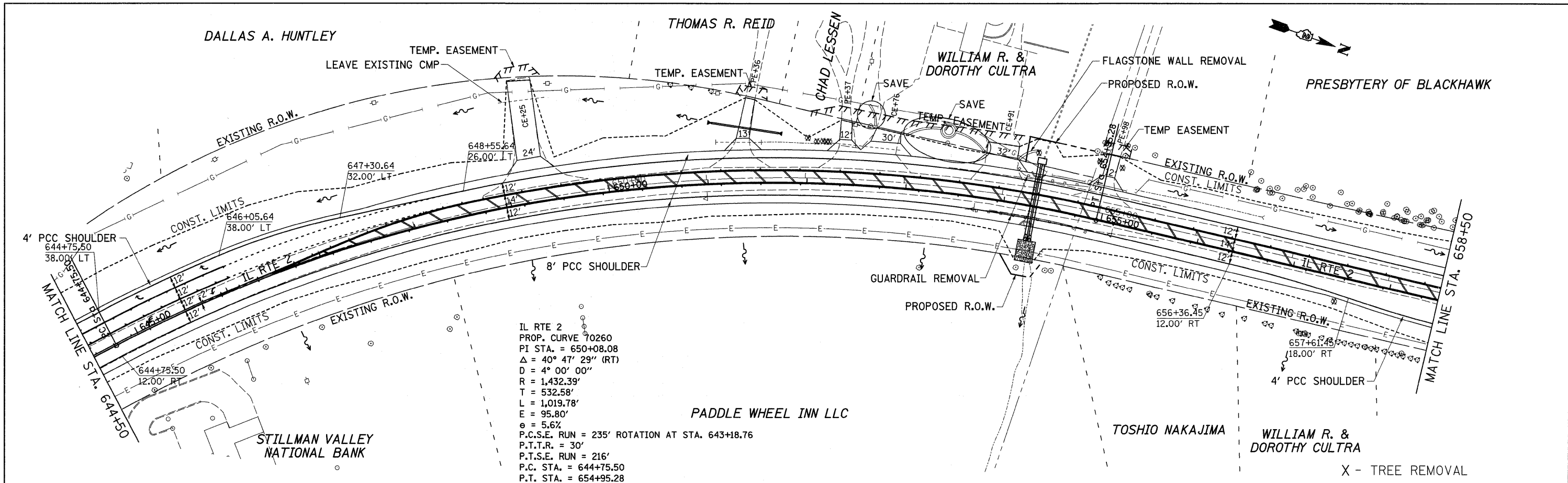

IL RTE 2  
 PROP. CURVE 70260  
 PI STA. = 650+08.08  
 $\Delta = 40^\circ 47' 29''$  (RT)  
 $D = 4^\circ 00' 00''$   
 $R = 1,432.39'$   
 $T = 532.58'$   
 $L = 1,019.78'$   
 $E = 95.80'$   
 $\theta = 5.6\%$   
 P.C.S.E. RUN = 235' ROTATION AT STA. 643+18.76  
 P.T.T.R. = 30'  
 P.T.S.E. RUN = 216'  
 P.C. STA. = 644+75.50  
 P.T. STA. = 654+95.28

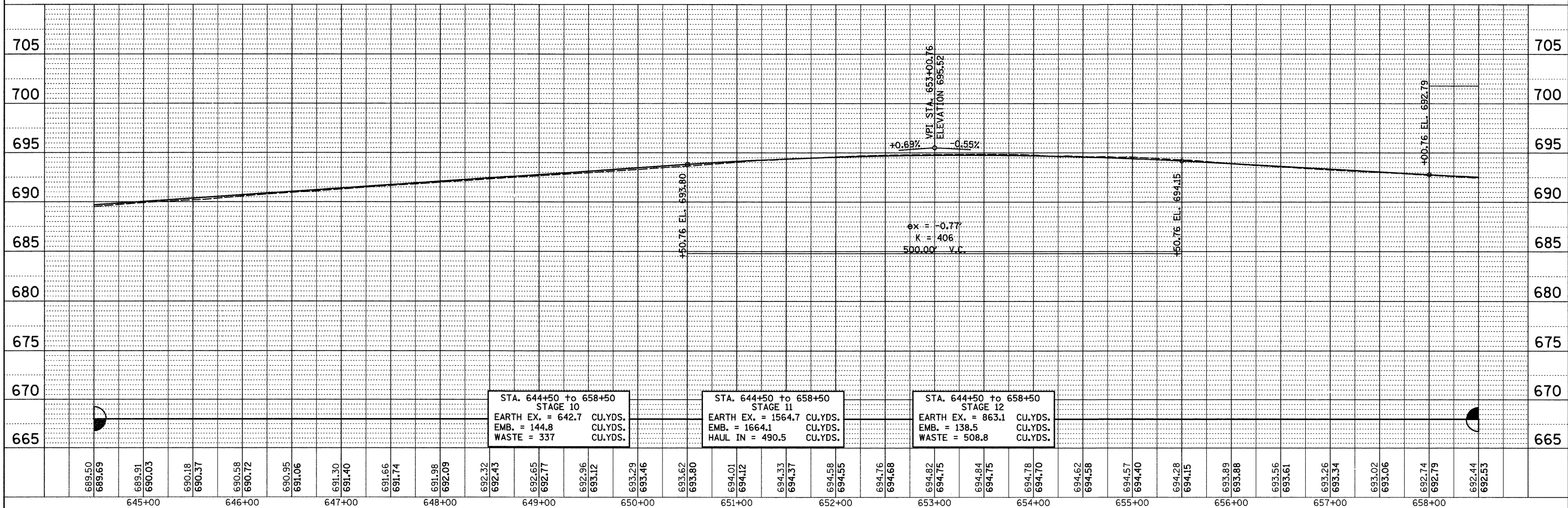

STA. 644+50 to 658+50  
 STAGE 10  
 EARTH EX. = 642.7 CU.YDS.  
 EMB. = 144.8 CU.YDS.  
 WASTE = 337 CU.YDS.

STA. 644+50 to 658+50  
 STAGE 11  
 EARTH EX. = 1564.7 CU.YDS.  
 EMB. = 1664.1 CU.YDS.  
 HAUL IN = 490.5 CU.YDS.

STA. 644+50 to 658+50  
 STAGE 12  
 EARTH EX. = 863.1 CU.YDS.  
 EMB. = 138.5 CU.YDS.  
 WASTE = 508.8 CU.YDS.

FILE NAME =	USER NAME = cushmanbw	DESIGNED -	REVISED -	F.A.P. RTE. 742	SECTION 37R-3	COUNTY OGLE	TOTAL SHEETS 345	SHEET NO. 60
c:\pwwork\KPIWIDOT\CUSHMANBW\dms34123\d06186p1n1.dgn		DRAWN -	REVISED -	SCALE: SHEET NO. OF SHEETS STA. TO STA.		CONTRACT NO. 84788		
PLOT SCALE = 50.0000' / IN.		CHECKED -	REVISED -	FED. ROAD DIST. NO. (ILLINOIS) FED. AID PROJECT				
PLOT DATE = Thu Apr 30 15:38:57 2009		DATE -	REVISED -					

STATE OF ILLINOIS  
 DEPARTMENT OF TRANSPORTATION

PLAN & PROFILE



PLAN	SURVEYED	DATE
	PLOTTED	
	NOTED	
	REVISIONS	
	BY	
	DATE	
	NO.	

PROFILE	SURVEYED	DATE
	PLOTTED	
	NOTED	
	REVISIONS	
	BY	
	DATE	
	NO.	

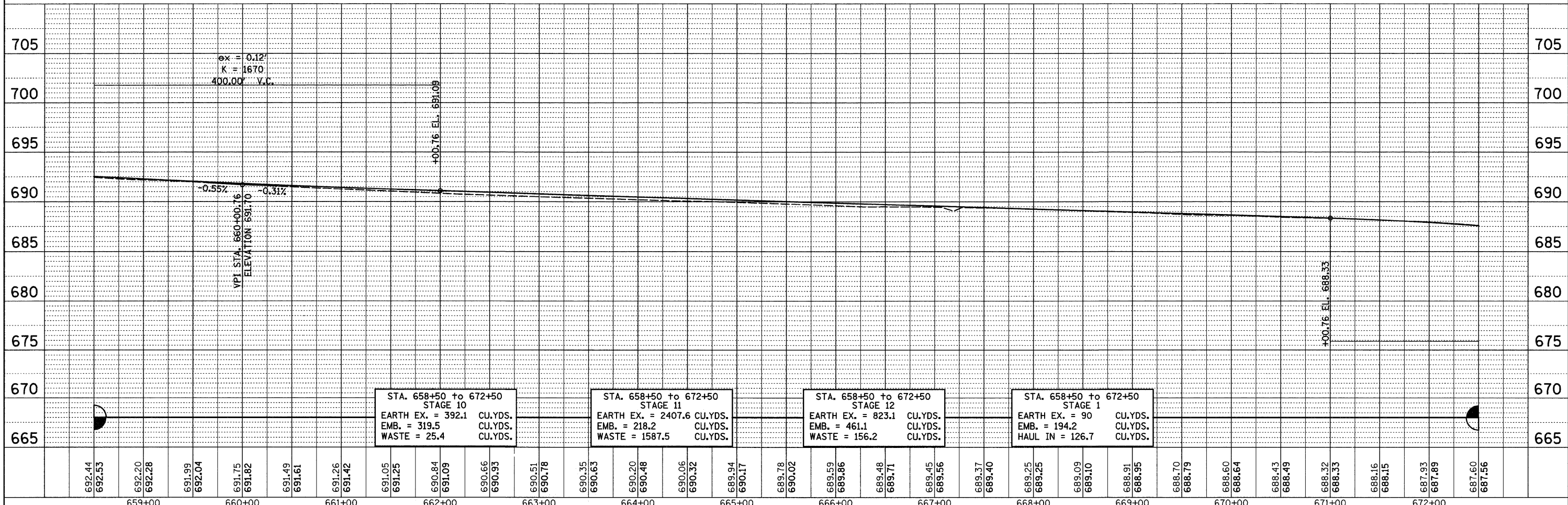
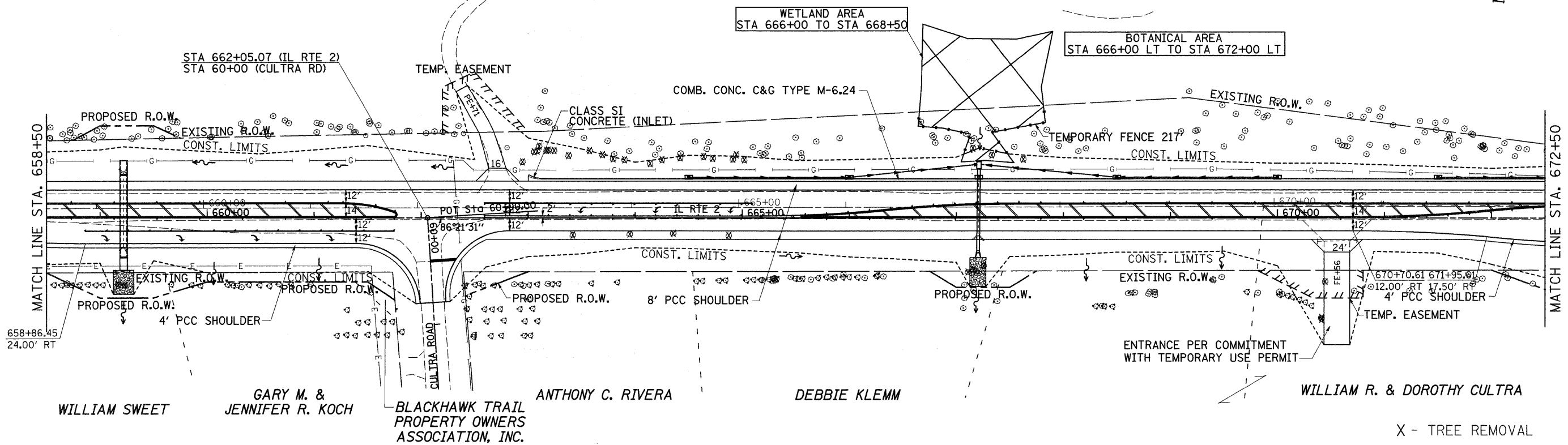

FILE NAME =	USER NAME = cushmanbw	DESIGNED -	REVISED -	F.A.P. RTE.	SECTION	COUNTY	TOTAL SHEETS	SHEET NO.
es:\pw\work\PIWIDOT\CUSHMANBW\dms34123\ad0586p1n1.dgn		DRAWN -	REVISED -	742	37R-3	OGLE	345	61
PLOT SCALE = 50.0000' / IN.		CHECKED -	REVISED -	CONTRACT NO. 84788				
PLOT DATE = Thu Apr 30 15:38:58 2009		DATE -	REVISED -	SCALE:	SHEET NO.	OF SHEETS	STA.	TO STA.
								FED. ROAD DIST. NO. ILLINOIS FED. AID PROJECT

STATE OF ILLINOIS  
DEPARTMENT OF TRANSPORTATION

PLAN & PROFILE

DATE	BY
REVISIONS	PLANNED
NOTE BOOK	CHECKED
NO.	DATE

DATE	BY
REVISIONS	PLANNED
NOTE BOOK	CHECKED
NO.	DATE

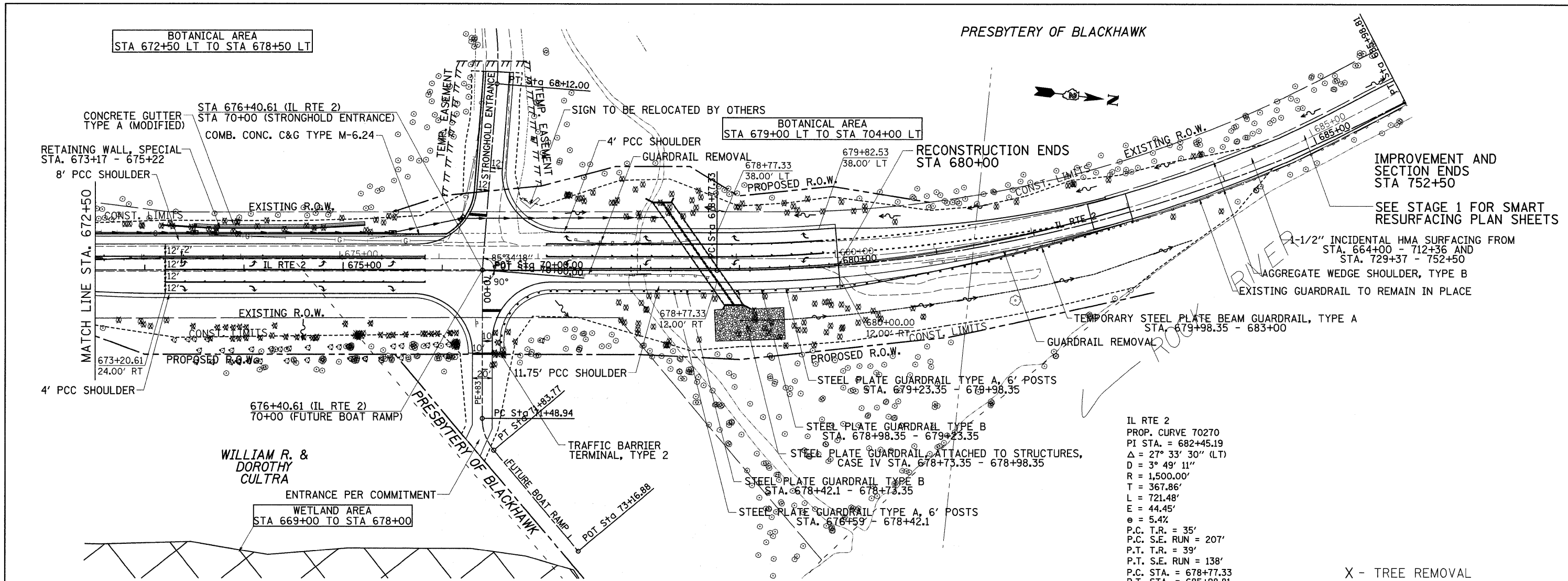

IL RTE 2  
 PROP. CURVE 70270  
 PI STA. = 682+45.19  
 $\Delta = 27^\circ 33' 30''$  (LT)  
 $D = 3^\circ 49' 11''$   
 $R = 1,500.00'$   
 $T = 367.86'$   
 $L = 721.48'$   
 $E = 44.45'$   
 $e = 5.4\%$   
 P.C. T.R. = 35'  
 P.C. S.E. RUN = 207'  
 P.T. T.R. = 39'  
 P.T. S.E. RUN = 138'  
 P.C. STA. = 678+77.33  
 P.T. STA. = 685+98.81

X - TREE REMOVAL

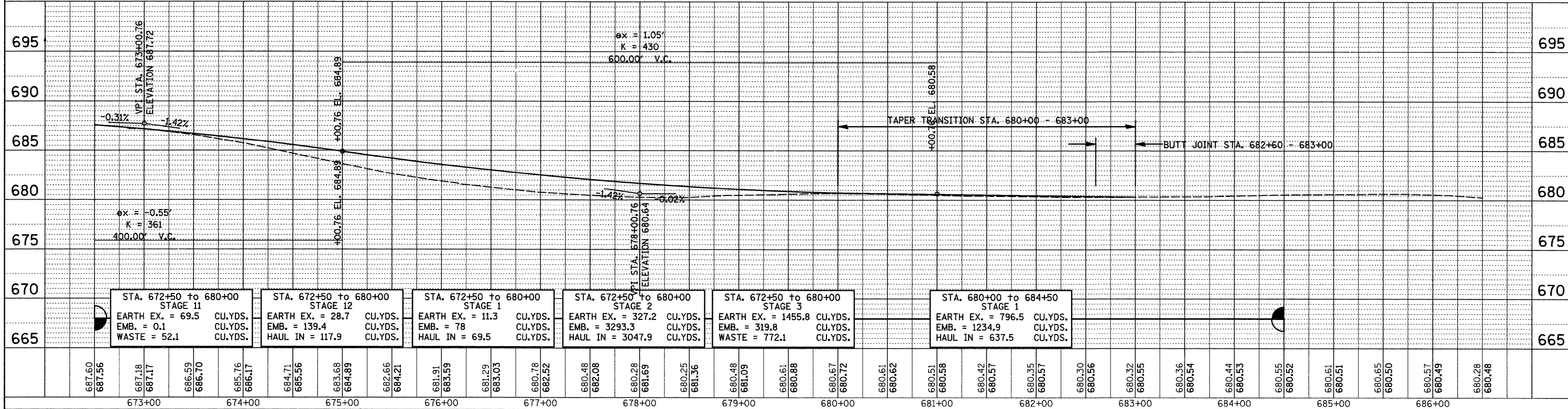

STA. 672+50 to 680+00 STAGE 11 EARTH EX. = 69.5 CU.YDS. EMB. = 0.1 CU.YDS. WASTE = 52.1 CU.YDS.	STA. 672+50 to 680+00 STAGE 12 EARTH EX. = 28.7 CU.YDS. EMB. = 139.4 CU.YDS. HAUL IN = 117.9 CU.YDS.	STA. 672+50 to 680+00 STAGE 1 EARTH EX. = 11.3 CU.YDS. EMB. = 78 CU.YDS. HAUL IN = 69.5 CU.YDS.	STA. 672+50 to 680+00 STAGE 2 EARTH EX. = 327.2 CU.YDS. EMB. = 3293.3 CU.YDS. HAUL IN = 3047.9 CU.YDS.	STA. 672+50 to 680+00 STAGE 3 EARTH EX. = 1455.8 CU.YDS. EMB. = 319.8 CU.YDS. WASTE = 772.1 CU.YDS.	STA. 680+00 to 684+50 STAGE 1 EARTH EX. = 796.5 CU.YDS. EMB. = 1234.9 CU.YDS. HAUL IN = 637.5 CU.YDS.
---	--	---	--	---	---

FILE NAME =	USER NAME = perkinsdr	DESIGNED -	REVISED -	<b>STATE OF ILLINOIS DEPARTMENT OF TRANSPORTATION</b>		<b>PLAN &amp; PROFILE</b>		F.A.P. RTE.	SECTION	COUNTY	TOTAL SHEETS	SHEET NO.
os:\pwork\pwork\perkinsdr\dms34123\d86496pInl.dgn	DRAWN -	REVISED -	742					37R-3	OGLE	345	62	
PLOT SCALE = 58.0000' / IN.	CHECKED -	REVISED -	CONTRACT NO. 84788									
PLOT DATE = Fri Jun 05 14:42:47 2009	DATE -	REVISED -	ILLINOIS FED. AID PROJECT									
SCALE:		SHEET NO. OF SHEETS		STA. TO STA.								

# FAIR ST.

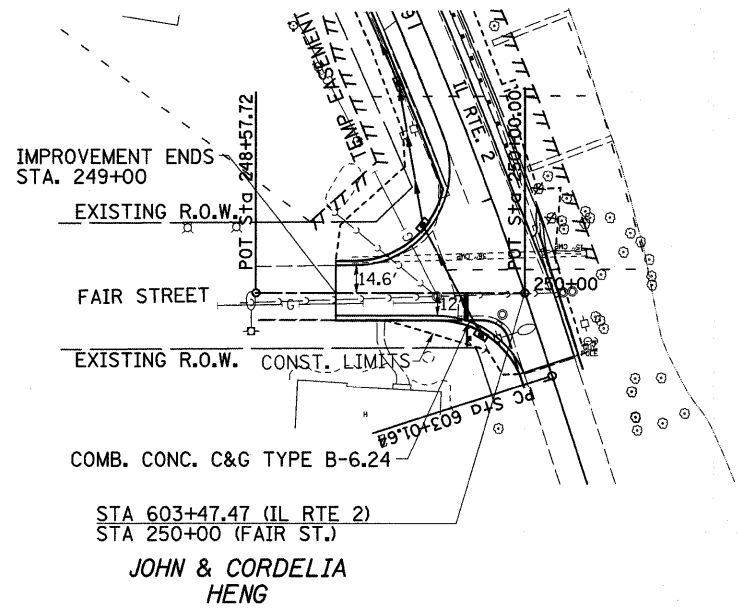

X - TREE REMOVAL

# MARGARET FULLER DR.

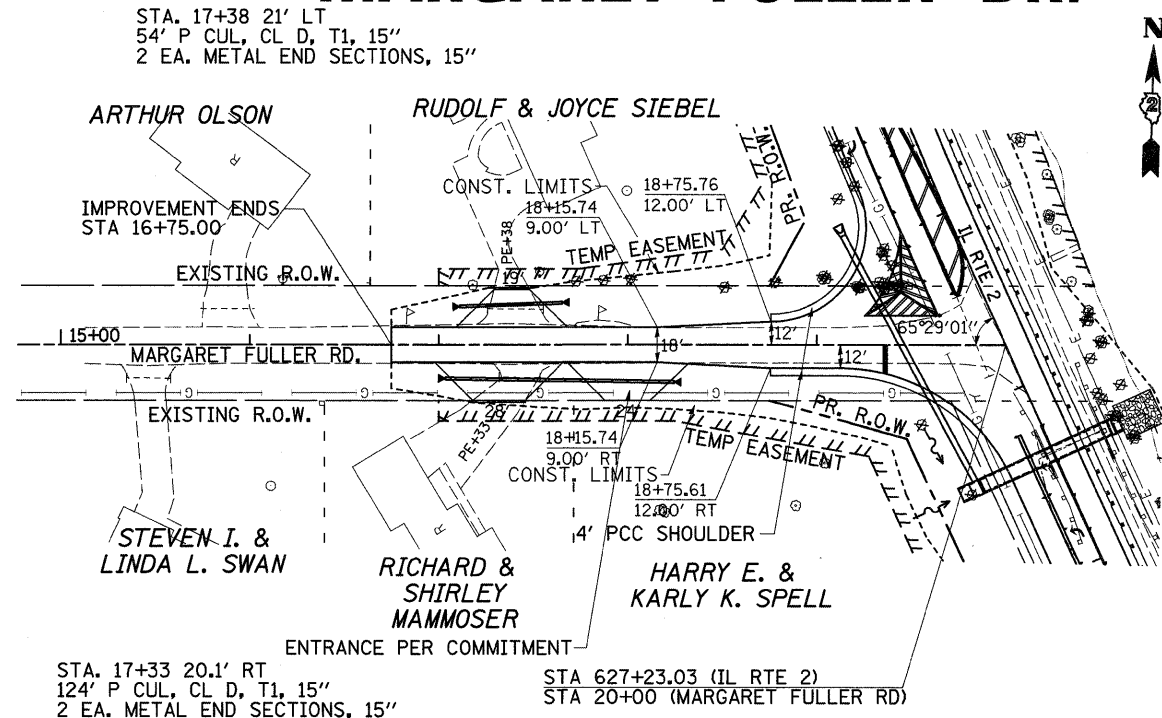

X - TREE REMOVAL

PLAN	SURVEYED	DATE
	PLOTTED	
	NOTED	
	CAD FILE NAME	

PROFILE	SURVEYED	DATE
	PLOTTED	
	NOTED	
	STRUCTURE NOTATIONS CHKD	

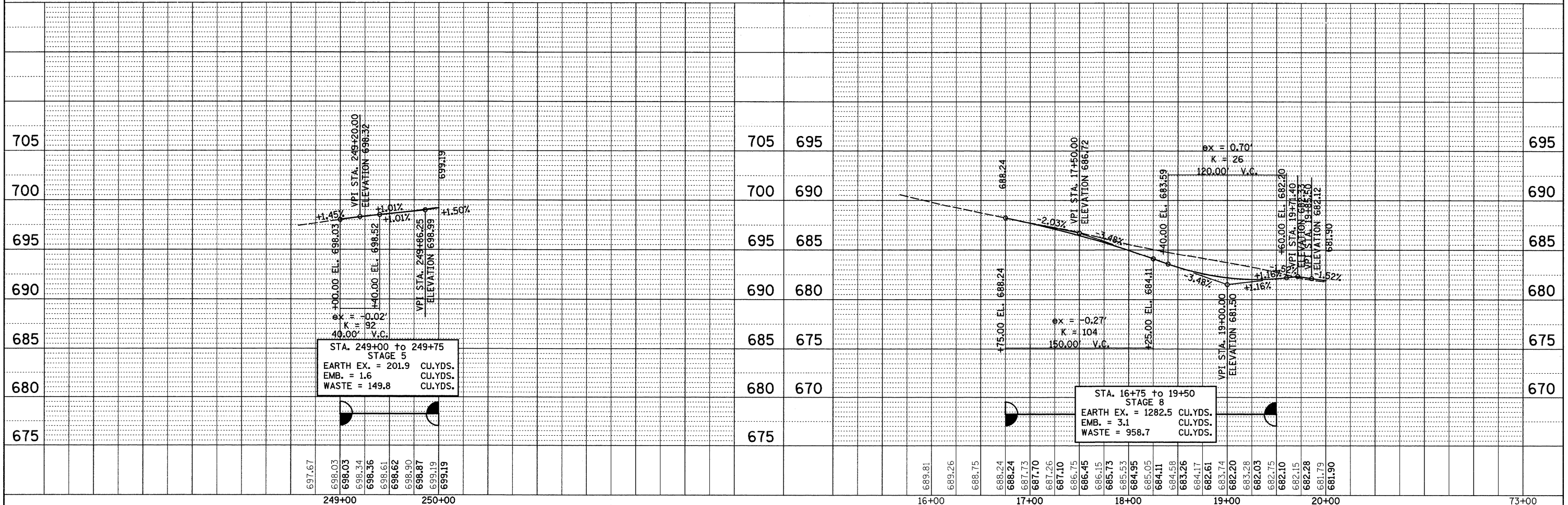

FILE NAME =	USER NAME = cushmanbw	DESIGNED -	REVISED -	<b>STATE OF ILLINOIS DEPARTMENT OF TRANSPORTATION</b>	<b>PLAN &amp; PROFILE</b>			F.A.P. RTE. 742	SECTION 37R-3	COUNTY OGLE	TOTAL SHEETS 345	SHEET NO. 63
ca:\pwwork\p\fidot\CUSHMANBW\dms34123\vd26186p1n3.dgn		DRAWN -	REVISED -		SCALE:	SHEET NO.	OF SHEETS	STA.	TO STA.	CONTRACT NO.		
		CHECKED -	REVISED -		FED. ROAD DIST. NO. [ILLINOIS] FED. AID PROJECT							
		DATE	REVISED -									



# BLACKHAWK VISTA

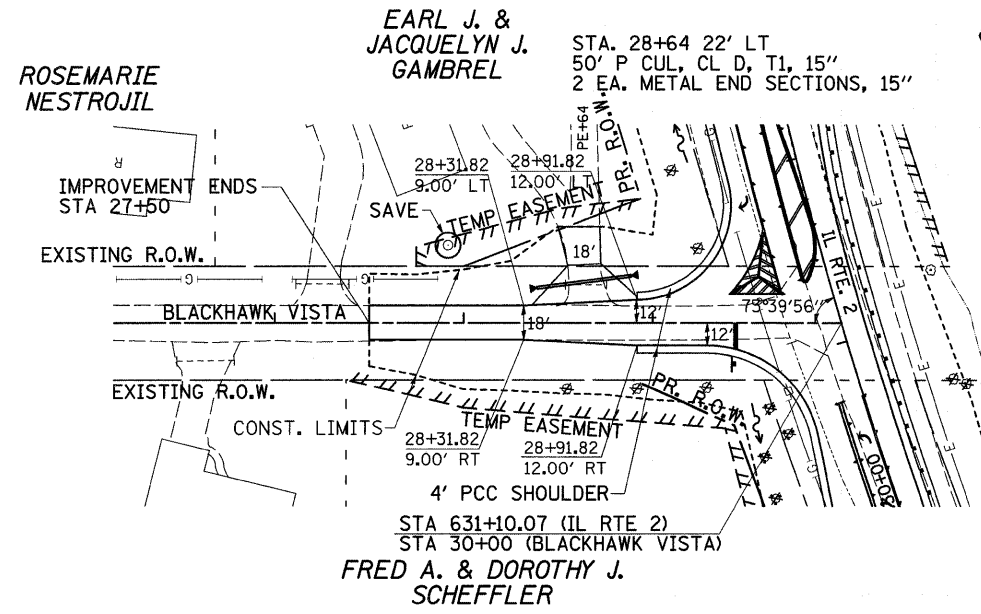

X - TREE REMOVAL

# CARTWRIGHT LN.

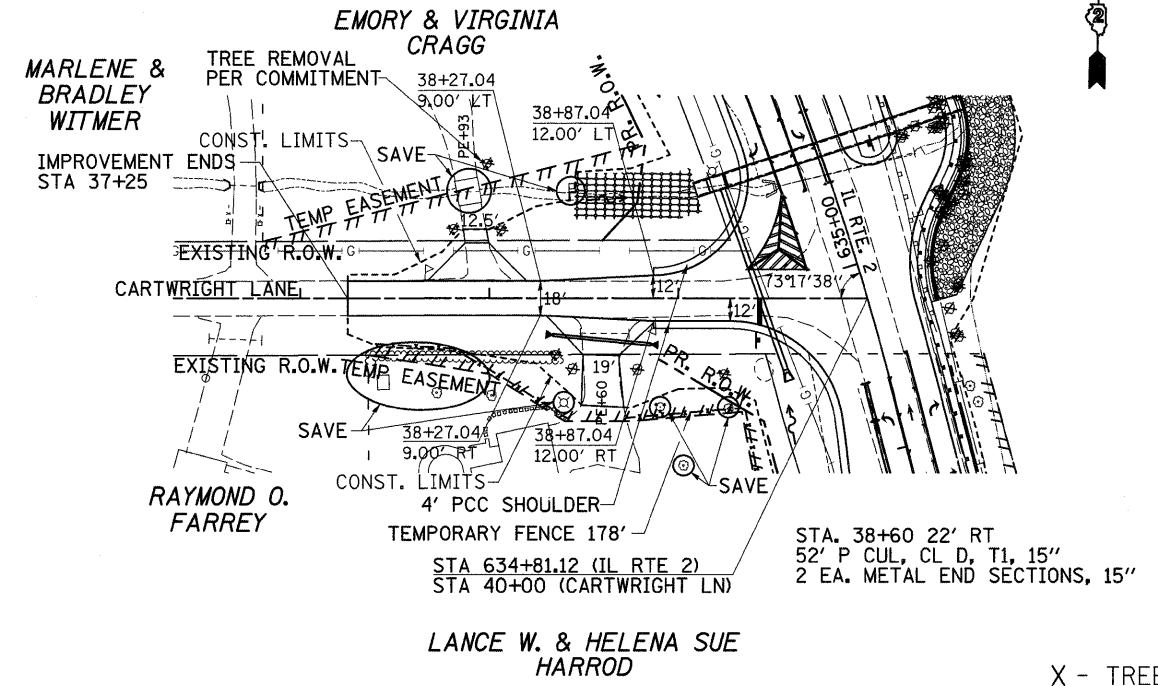

X - TREE REMOVAL

DATE	
BY	
SURVEYED	
PLOTTED	
FILED	
NOTE BOOK	
NO.	
CADD FILE NAME	

DATE	
BY	
SURVEYED	
PLOTTED	
FILED	
NOTE BOOK	
NO.	
STRUCTURE NOTATIONS CTRD	

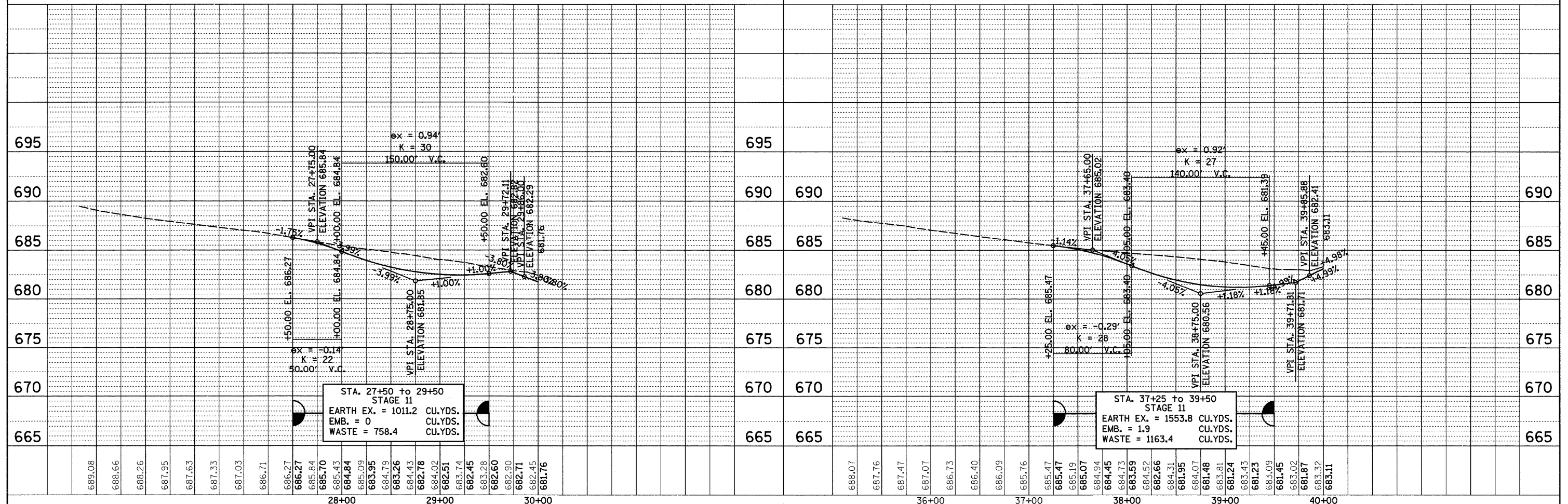

FILE NAME =	USER NAME = cushmanbw	DESIGNED -	REVISED -	<b>STATE OF ILLINOIS DEPARTMENT OF TRANSPORTATION</b>	<b>PLAN &amp; PROFILE</b>	F.A.P. RTE. 742	SECTION 37R-3	COUNTY OGLE	TOTAL SHEETS 345	SHEET NO. 64		
ct:\pw_wor-k\PIWIDOT\CUSHMANBW\dms34123\dl0686pln3.dgn	PLLOT SCALE = 50.0000' / IN.	DRAWN -	REVISED -			SCALE:	SHEET NO. OF SHEETS	STA. TO STA.	CONTRACT NO.			
	PLLOT DATE = Thu Apr 30 15:44:30 2009	CHECKED -	REVISED -			FED. ROAD DIST. NO. [ILLINOIS] FED. AID PROJECT						
		DATE -	REVISED -									

DATE	
BY	
SURVEYED	
PLOTTED	
NOTED	
NO.	

DATE	
BY	
SURVEYED	
PLOTTED	
NOTED	
NO.	

FILE NAME	USER NAME	DESIGNED	REVISED
DRAWN	CHECKED	REVISED	REVISED
DATE			

SCALE	SHEET NO.	OF SHEETS	STA.	TO STA.
-------	-----------	-----------	------	---------

# ACCESS ROAD A

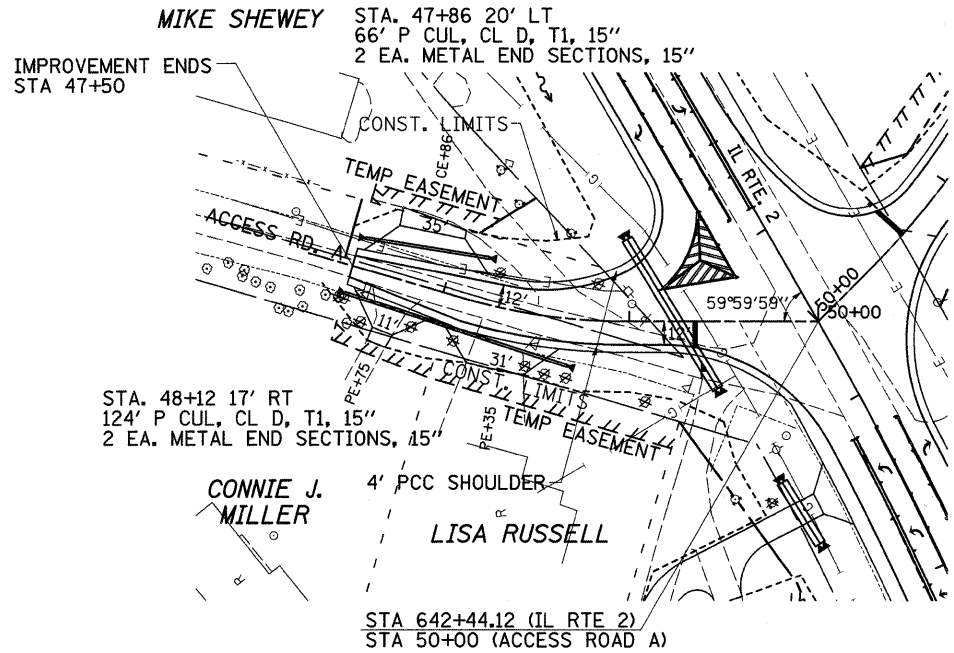

PROP. CURVE 71340  
 PI STA. = 48+55.06  
 $\Delta = 16^\circ 06' 47''$  (LT)  
 $D = 19^\circ 05' 55''$   
 $R = 300.00'$   
 $T = 42.46'$   
 $L = 84.37'$   
 $E = 2.99'$   
 $e = \text{---}$   
 $T.R. = \text{---}$   
 $S.E. RUN = \text{---}$   
 $P.C. STA. = 48+12.60$   
 $P.T. STA. = 48+96.96$

X - TREE REMOVAL

# ACCESS ROAD B

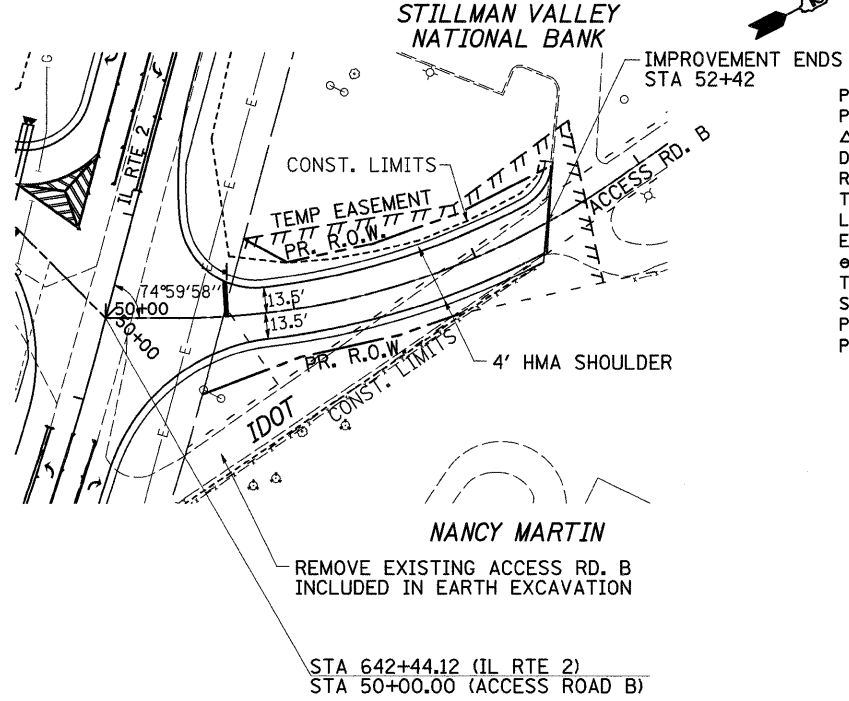

PROP. CURVE 71350  
 PI STA. = 51+64.69  
 $\Delta = 34^\circ 45' 24''$  (LT)  
 $D = 14^\circ 19' 26''$   
 $R = 400.00'$   
 $T = 125.19'$   
 $L = 242.65'$   
 $E = 19.13'$   
 $e = \text{---}$   
 $T.R. = \text{---}$   
 $S.E. RUN = \text{---}$   
 $P.C. STA. = 50+39.50$   
 $P.T. STA. = 52+82.15$

X - TREE REMOVAL

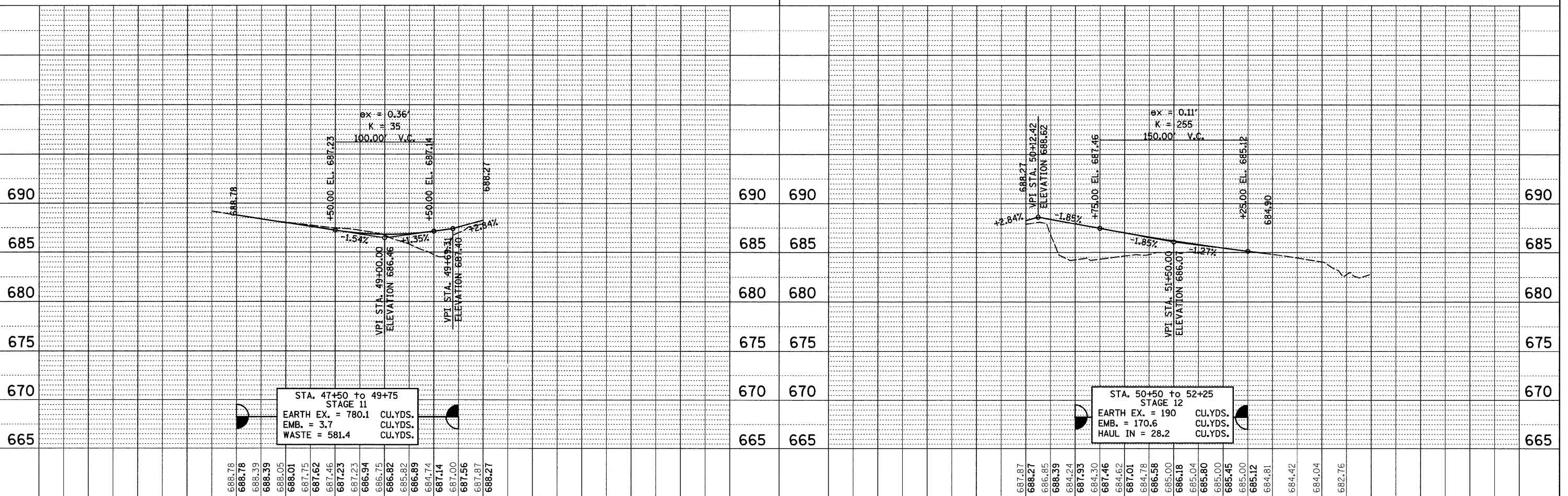

STA. 47+50 to 49+75  
 STAGE 11  
 EARTH EX. = 780.1 CU.YDS.  
 EMB. = 3.7 CU.YDS.  
 WASTE = 581.4 CU.YDS.

STA. 50+50 to 52+25  
 STAGE 12  
 EARTH EX. = 190 CU.YDS.  
 EMB. = 170.6 CU.YDS.  
 HAUL IN = 28.2 CU.YDS.

STATE OF ILLINOIS  
 DEPARTMENT OF TRANSPORTATION

## PLAN & PROFILE

F.A.P. RTE.	SECTION	COUNTY	TOTAL SHEETS	SHEET NO.
742	37R-3	OGLE	345	65
FED. ROAD DIST. NO.		ILLINOIS FED. AID PROJECT		

SCALE:	SHEET NO.	OF SHEETS	STA.	TO STA.
--------	-----------	-----------	------	---------



# STAGE 1

## STA. 603 + 08 - 752 + 50

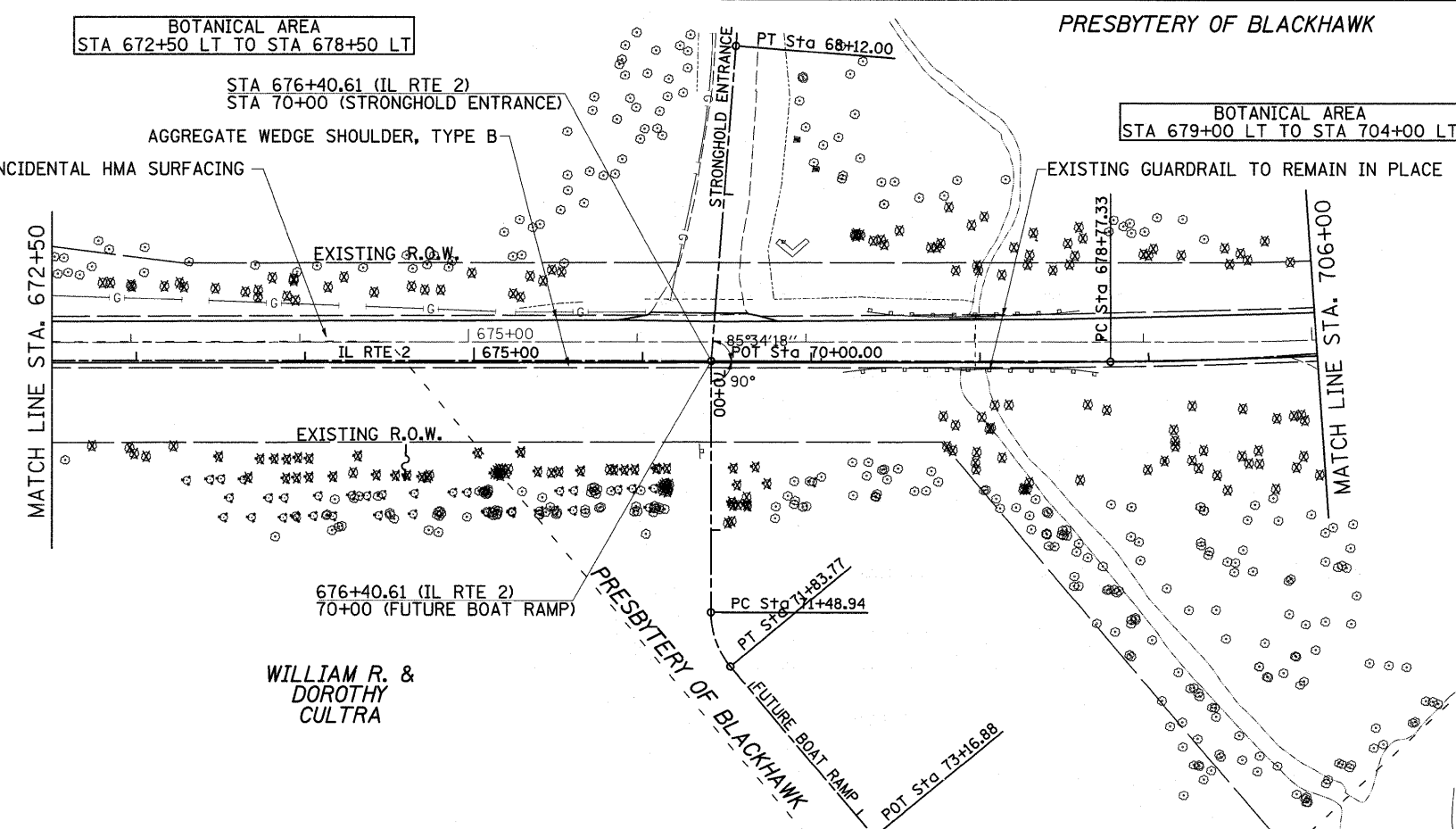
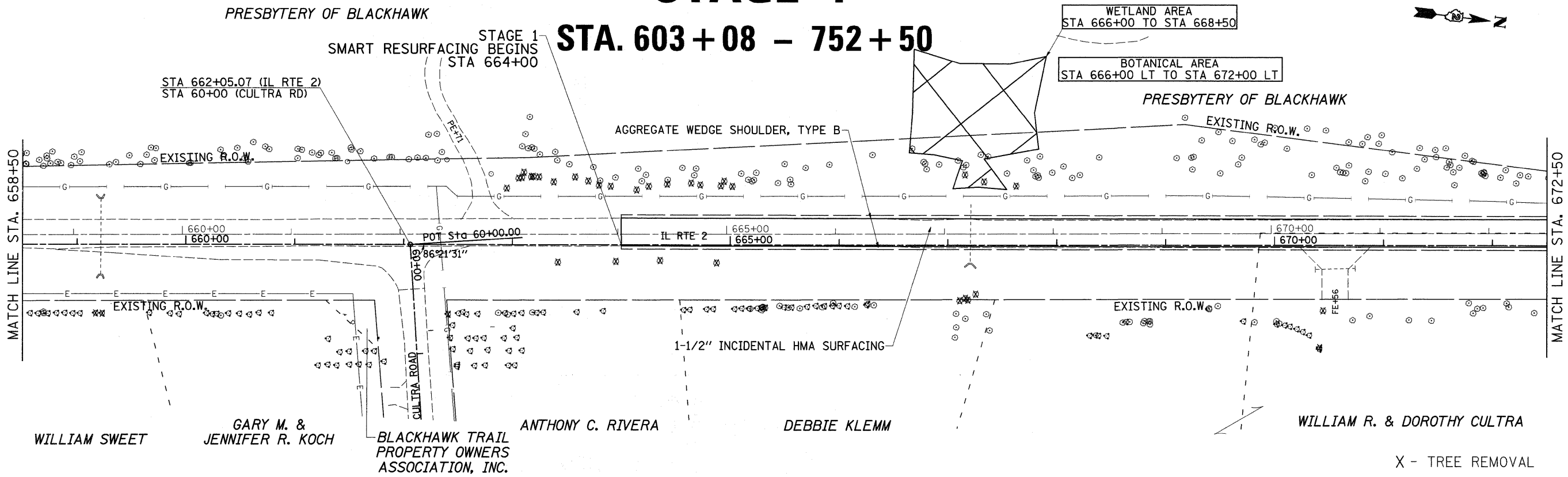

### STAGE 1 NOTES

1. USE STANDARD 701306 TO CONSTRUCT SMART RESURFACING FROM STA. 664+00 TO STA. 752+50. SEE STANDARDS FOR ADDITIONAL SIGNING AND DEVICES NOT SHOWN IN DETAILS.
2. USE STANDARD 701326 TO CONSTRUCT TEMPORARY PAVEMENT FROM STA. 669+50 TO 673+00 RT. AND FROM STA. 680+00 TO 683+00 RT. SIDE THEN LT. SIDE. SEE STANDARDS FOR ADDITIONAL SIGNING AND DEVICES NOT SHOWN IN DETAILS.
3. CONSTRUCT TEMPORARY PAVEMENT FROM LT. STA. 676+18 TO 676+41 IN STRONGHOLD ENTRANCE (SEE STAGE 2).
4. REMOVE EXISTING GUARDRAIL STA. 680+84 - 683+00.
5. INSTALL TEMPORARY STEEL PLATE BEAM GUARDRAIL, TYPE A FROM STA. 680+00 - 683+00.
6. INSTALL IMPACT ATTENUATOR, TEMPORARY AT STA. 680+00 RT.
7. USE STANDARD 701201 TO CONSTRUCT DOWNSTREAM ENDS OF CULVERTS LOCATED AT STA. 626+61, STA. 635+63, STA. 654+30, STA. 659+22, AND STA. 667+20. (MAINTAIN EXISTING FLOW)
8. USE STANDARD 701201 TO CONSTRUCT UPSTREAM ENDS OF CULVERTS LOCATED AT STA. 626+61, STA. 635+63, STA. 654+30, STA. 659+22, AND STA. 667+20 AND ANY SIDE ROAD CULVERTS NECESSARY. (MAINTAIN EXISTING FLOW)
9. PLACE CLASS D PATCH FOR WORK AREAS (MATCH EXISTING PAVEMENT).
10. INSTALL TRAFFIC BARRIER TERMINALS FROM STA. 626+11 TO 627+11.

ROCK RIVER

X - TREE REMOVAL

FILE NAME =	USER NAME = perkinsdr	DESIGNED -	REVISED -	<b>STATE OF ILLINOIS DEPARTMENT OF TRANSPORTATION</b>	<b>STAGE 1</b>	F.A.P. RTE.	SECTION	COUNTY	TOTAL SHEETS	SHEET NO.	
ca:\pw_work\pwsdot\perkinsdr\dms34123\dms486stg69.dgn		DRAWN -	REVISED -			742	37R-3	OGLE	345	66 A	
PLOT SCALE = 50,0000' / IN.		CHECKED -	REVISED -			CONTRACT NO. 84788					
PLOT DATE = Fri Jun 05 14:07:26 2009		DATE -	REVISED -			ILLINOIS FED. AID PROJECT					
SCALE: SHEET NO. OF SHEETS STA. TO STA.											

# STAGE 1

## STA. 603 + 08 - 752 + 50

PRESBYTERY OF BLACKHAWK

BOTANICAL AREA  
STA 679+00 LT TO STA 704+00 LT

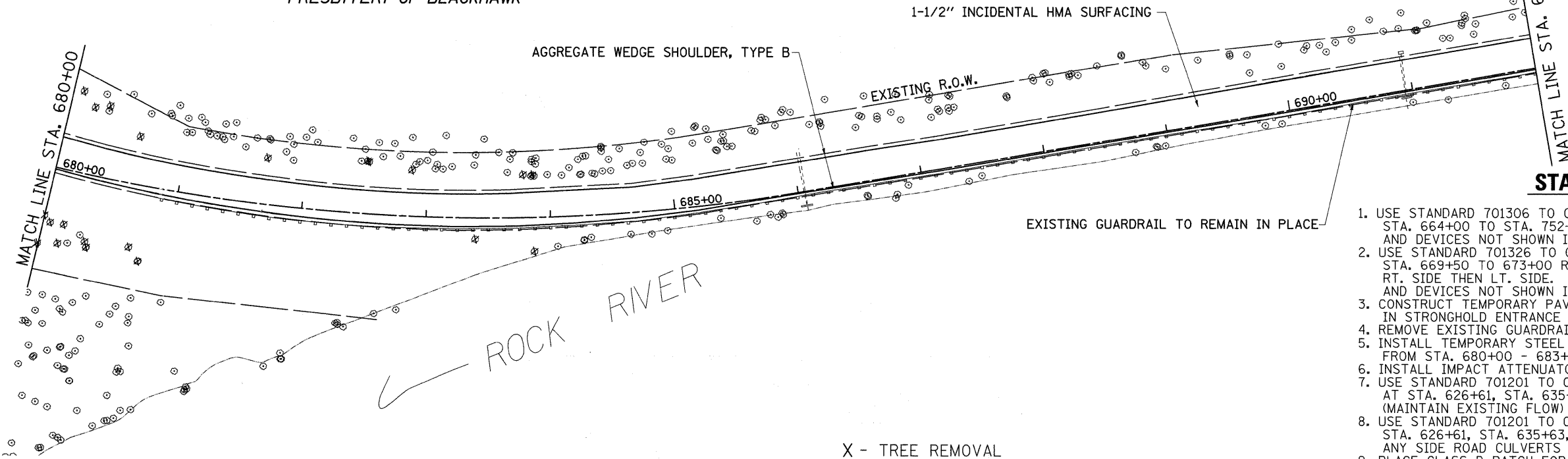

### STAGE 1 NOTES

1. USE STANDARD 701306 TO CONSTRUCT SMART RESURFACING FROM STA. 664+00 TO STA. 752+50. SEE STANDARDS FOR ADDITIONAL SIGNING AND DEVICES NOT SHOWN IN DETAILS.
2. USE STANDARD 701326 TO CONSTRUCT TEMPORARY PAVEMENT FROM STA. 669+50 TO 673+00 RT. AND FROM STA. 680+00 TO 683+00 RT. SIDE THEN LT. SIDE. SEE STANDARDS FOR ADDITIONAL SIGNING AND DEVICES NOT SHOWN IN DETAILS.
3. CONSTRUCT TEMPORARY PAVEMENT FROM LT. STA. 676+18 TO 676+41 IN STRONGHOLD ENTRANCE (SEE STAGE 2).
4. REMOVE EXISTING GUARDRAIL STA. 680+84 - 683+00.
5. INSTALL TEMPORARY STEEL PLATE BEAM GUARDRAIL, TYPE A FROM STA. 680+00 - 683+00.
6. INSTALL IMPACT ATTENUATOR, TEMPORARY AT STA. 680+00 RT.
7. USE STANDARD 701201 TO CONSTRUCT DOWNSTREAM ENDS OF CULVERTS LOCATED AT STA. 626+61, STA. 635+63, STA. 654+30, STA. 659+22, AND STA. 667+20. (MAINTAIN EXISTING FLOW)
8. USE STANDARD 701201 TO CONSTRUCT UPSTREAM ENDS OF CULVERTS LOCATED AT STA. 626+61, STA. 635+63, STA. 654+30, STA. 659+22, AND STA. 667+20 AND ANY SIDE ROAD CULVERTS NECESSARY. (MAINTAIN EXISTING FLOW)
9. PLACE CLASS D PATCH FOR WORK AREAS (MATCH EXISTING PAVEMENT).
10. INSTALL TRAFFIC BARRIER TERMINALS FROM STA. 626+11 TO 627+11.

DATE	
BY	
REVISIONS	
NO.	
DESCRIPTION	
DATE	
BY	
NO.	
DESCRIPTION	
DATE	
BY	
NO.	
DESCRIPTION	

DATE	
BY	
REVISIONS	
NO.	
DESCRIPTION	
DATE	
BY	
NO.	
DESCRIPTION	
DATE	
BY	
NO.	
DESCRIPTION	

PRESBYTERY OF BLACKHAWK

PRESBYTERY OF BLACKHAWK

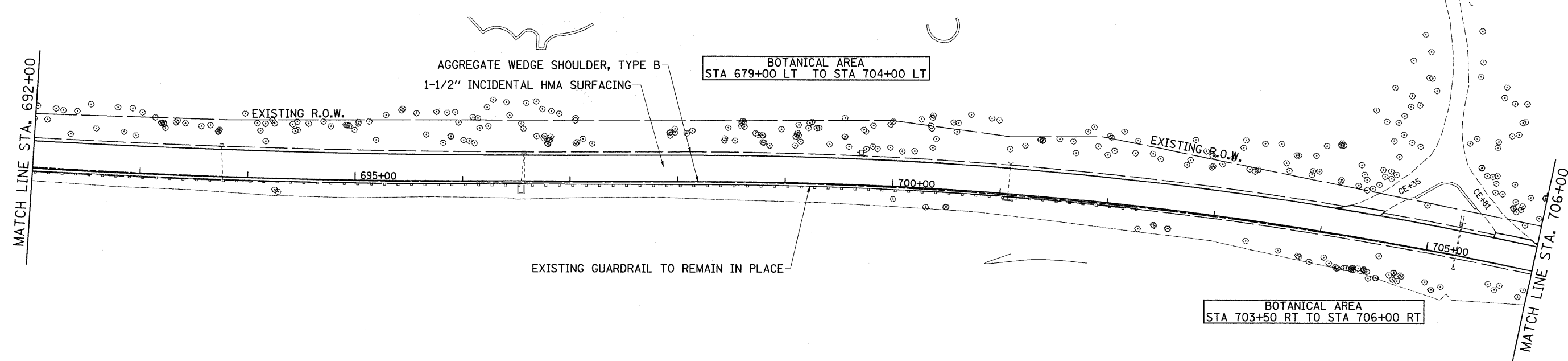

X - TREE REMOVAL

FILE NAME =	USER NAME = perkinsdr	DESIGNED -	REVISED -	<b>STATE OF ILLINOIS DEPARTMENT OF TRANSPORTATION</b>	<b>STAGE 1</b>	F.A.P. RTE.	SECTION	COUNTY	TOTAL SHEETS	SHEET NO.	
cr:\pw\work\p1\dot\perkinsdr\dms34123\486	486stg69.dgn	DRAWN -	REVISED -			742	37R-3	OGLE	345	66 B	
	PLOT SCALE = 50,0000' / IN.	CHECKED -	REVISED -			CONTRACT NO. 84788					
	PLOT DATE = Fri Jun 05 14:07:23 2009	DATE -	REVISED -			ILLINOIS FED. AID PROJECT					
						SCALE:	SHEET NO.	OF	SHEETS	STA.	TO STA.

# STAGE 1

## STA. 603+08 - 752+50

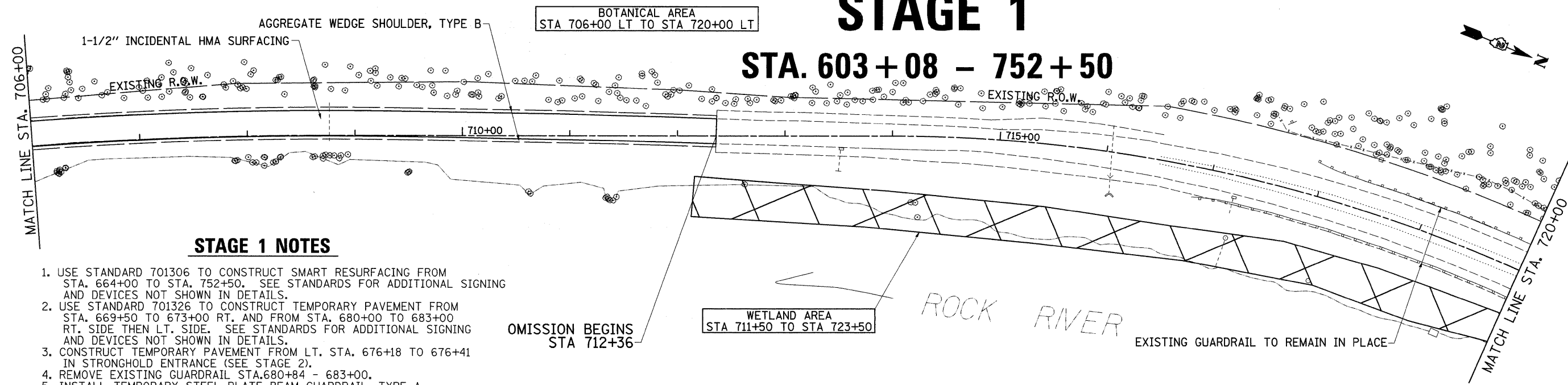

### STAGE 1 NOTES

1. USE STANDARD 701306 TO CONSTRUCT SMART RESURFACING FROM STA. 664+00 TO STA. 752+50. SEE STANDARDS FOR ADDITIONAL SIGNING AND DEVICES NOT SHOWN IN DETAILS.
2. USE STANDARD 701326 TO CONSTRUCT TEMPORARY PAVEMENT FROM STA. 669+50 TO 673+00 RT. AND FROM STA. 680+00 TO 683+00 RT. SIDE THEN LT. SIDE. SEE STANDARDS FOR ADDITIONAL SIGNING AND DEVICES NOT SHOWN IN DETAILS.
3. CONSTRUCT TEMPORARY PAVEMENT FROM LT. STA. 676+18 TO 676+41 IN STRONGHOLD ENTRANCE (SEE STAGE 2).
4. REMOVE EXISTING GUARDRAIL STA.680+84 - 683+00.
5. INSTALL TEMPORARY STEEL PLATE BEAM GUARDRAIL, TYPE A FROM STA. 680+00 - 683+00.
6. INSTALL IMPACT ATTENUATOR, TEMPORARY AT STA. 680+00 RT.
7. USE STANDARD 701201 TO CONSTRUCT DOWNSTREAM ENDS OF CULVERTS LOCATED AT STA. 626+61, STA. 635+63, STA. 654+30, STA. 659+22, AND STA. 667+20. (MAINTAIN EXISTING FLOW)
8. USE STANDARD 701201 TO CONSTRUCT UPSTREAM ENDS OF CULVERTS LOCATED AT STA. 626+61, STA. 635+63, STA. 654+30, STA. 659+22, AND STA. 667+20 AND ANY SIDE ROAD CULVERTS NECESSARY. (MAINTAIN EXISTING FLOW)
9. PLACE CLASS D PATCH FOR WORK AREAS (MATCH EXISTING PAVEMENT).
10. INSTALL TRAFFIC BARRIER TERMINALS FROM STA. 626+11 TO 627+11.

OMISSION BEGINS STA 712+36

WETLAND AREA STA 711+50 TO STA 723+50

ROCK RIVER

EXISTING GUARDRAIL TO REMAIN IN PLACE

X - TREE REMOVAL

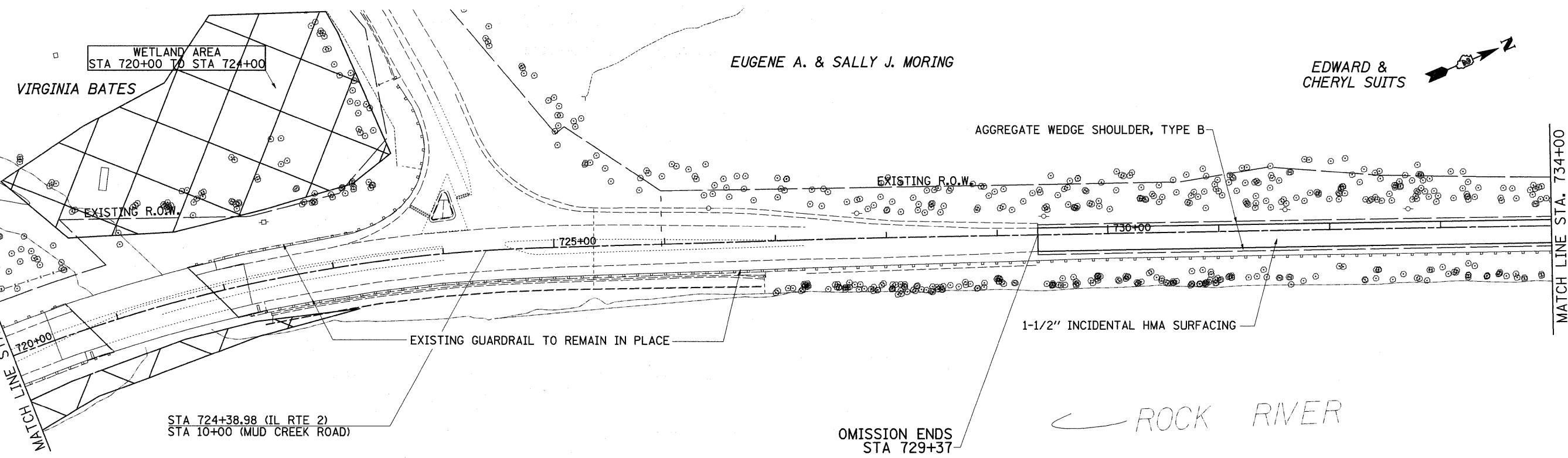

WETLAND AREA STA 720+00 TO STA 724+00

EUGENE A. & SALLY J. MORING

EDWARD & CHERYL SUITS

AGGREGATE WEDGE SHOULDER, TYPE B

EXISTING R.O.W.

1-1/2" INCIDENTAL HMA SURFACING

EXISTING GUARDRAIL TO REMAIN IN PLACE

STA 724+38.98 (IL RTE 2)  
STA 10+00 (MUD CREEK ROAD)

OMISSION ENDS STA 729+37

ROCK RIVER

X - TREE REMOVAL

FILE NAME =	USER NAME = perknsdr	DESIGNED -	REVISED -	<b>STATE OF ILLINOIS DEPARTMENT OF TRANSPORTATION</b>	<b>STAGE 1</b>			F.A.P. RTE.	SECTION	COUNTY	TOTAL SHEETS	SHEET NO.
ct:\pw_work\p1dot\perknsdr\dms34123\d08496stg69.dgn		DRAWN -	REVISED -		742	37R-3	OGLE	345	66 C			
		CHECKED -	REVISED -		CONTRACT NO. 84788							
		DATE -	REVISED -		ILLINOIS FED. AID PROJECT							
				SCALE:	SHEET NO.	OF	SHEETS	STA.	TO STA.			

# STAGE 1

STA. 603+08 - 752+50

EDWARD & CHERYL SUITS

EUGENE A. & SALLY J. MORING

BARBARA A. GAERTNER

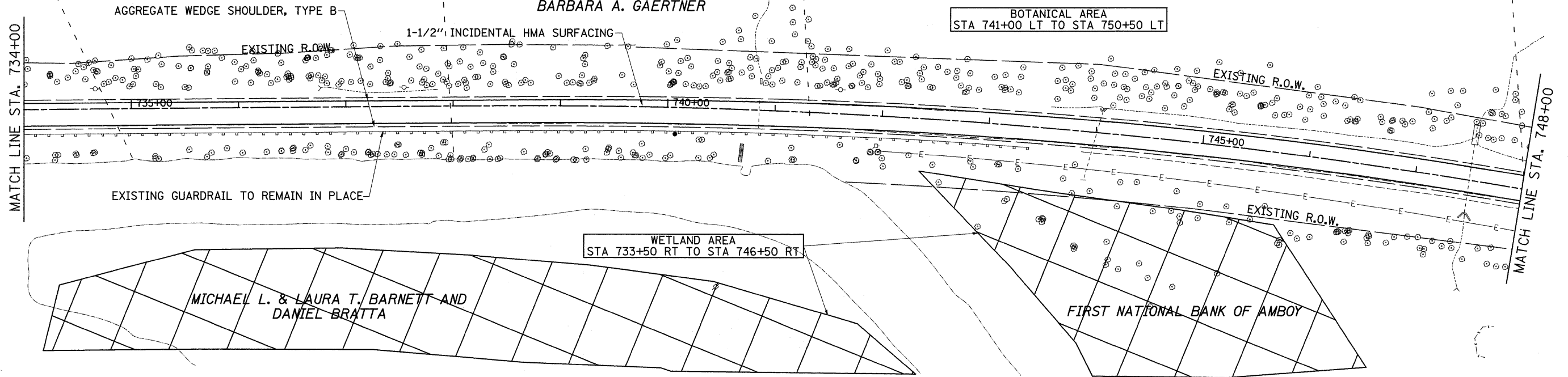

X - TREE REMOVAL

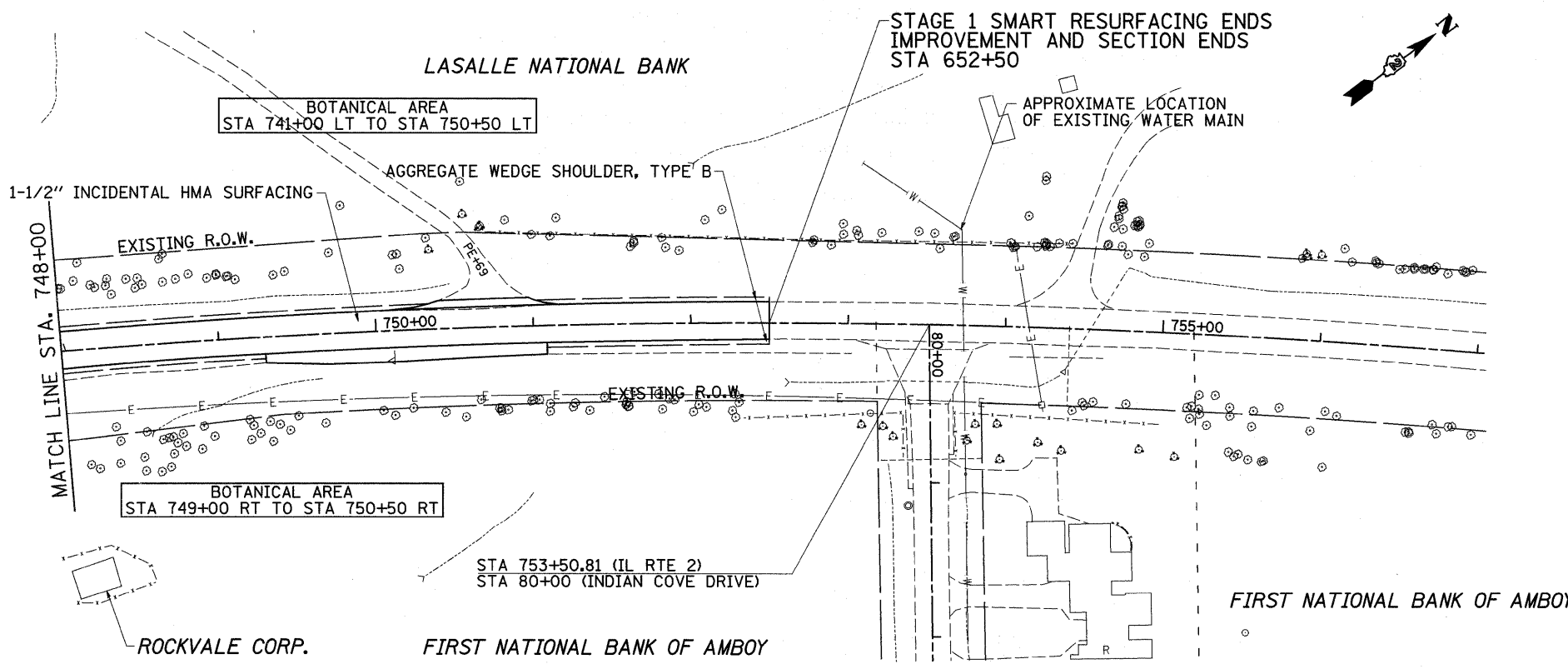

X - TREE REMOVAL

## STAGE 1 NOTES

1. USE STANDARD 701306 TO CONSTRUCT SMART RESURFACING FROM STA. 664+00 TO STA. 752+50. SEE STANDARDS FOR ADDITIONAL SIGNING AND DEVICES NOT SHOWN IN DETAILS.
2. USE STANDARD 701326 TO CONSTRUCT TEMPORARY PAVEMENT FROM STA. 669+50 TO 673+00 RT. AND FROM STA. 680+00 TO 683+00 RT. SIDE THEN LT. SIDE. SEE STANDARDS FOR ADDITIONAL SIGNING AND DEVICES NOT SHOWN IN DETAILS.
3. CONSTRUCT TEMPORARY PAVEMENT FROM LT. STA. 676+18 TO 676+41 IN STRONGHOLD ENTRANCE (SEE STAGE 2).
4. REMOVE EXISTING GUARDRAIL STA. 680+84 - 683+00.
5. INSTALL TEMPORARY STEEL PLATE BEAM GUARDRAIL, TYPE A FROM STA. 680+00 - 683+00.
6. INSTALL IMPACT ATTENUATOR, TEMPORARY AT STA. 680+00 RT.
7. USE STANDARD 701201 TO CONSTRUCT DOWNSTREAM ENDS OF CULVERTS LOCATED AT STA. 626+61, STA. 635+63, STA. 654+30, STA. 659+22, AND STA. 667+20. (MAINTAIN EXISTING FLOW)
8. USE STANDARD 701201 TO CONSTRUCT UPSTREAM ENDS OF CULVERTS LOCATED AT STA. 626+61, STA. 635+63, STA. 654+30, STA. 659+22, AND STA. 667+20 AND ANY SIDE ROAD CULVERTS NECESSARY. (MAINTAIN EXISTING FLOW)
9. PLACE CLASS D PATCH FOR WORK AREAS (MATCH EXISTING PAVEMENT).
10. INSTALL TRAFFIC BARRIER TERMINALS FROM STA. 626+11 TO 627+11.

FILE NAME =	USER NAME = perknsdr	DESIGNED -	REVISED -	<b>STATE OF ILLINOIS DEPARTMENT OF TRANSPORTATION</b>	<b>STAGE 1</b>	F.A.P. RTE.	SECTION	COUNTY	TOTAL SHEETS	SHEET NO.	
ca:\pw_work\p\stod\perknsdr\dms34123\d8486stg6r.dgn	PLOT SCALE = 50.0000' / IN.	DRAWN -	REVISED -			742	37R-3	OGLE	345	66 D	
	PLOT DATE = Fri Jun 05 14:07:25 2009	CHECKED -	REVISED -			CONTRACT NO. 84788					
		DATE -	REVISED -			ILLINOIS FED. AID PROJECT					

# STAGE 1

## STA. 603 + 08 - 752 + 50

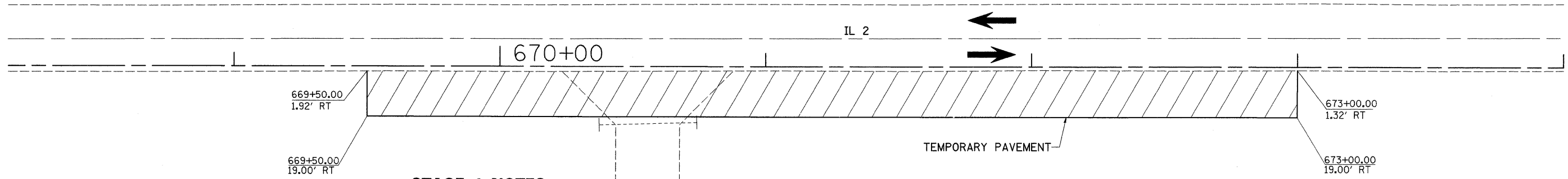

### STAGE 1 NOTES

1. USE STANDARD 701306 TO CONSTRUCT SMART RESURFACING FROM STA. 664+00 TO STA. 752+50. SEE STANDARDS FOR ADDITIONAL SIGNING AND DEVICES NOT SHOWN IN DETAILS.
2. USE STANDARD 701326 TO CONSTRUCT TEMPORARY PAVEMENT FROM STA. 669+50 TO 673+00 RT. AND FROM STA. 680+00 TO 683+00 RT. SIDE THEN LT. SIDE. SEE STANDARDS FOR ADDITIONAL SIGNING AND DEVICES NOT SHOWN IN DETAILS.
3. CONSTRUCT TEMPORARY PAVEMENT FROM LT. STA. 676+18 TO 676+41 IN STRONGHOLD ENTRANCE (SEE STAGE 2).
4. REMOVE EXISTING GUARDRAIL STA.680+84 - 683+00.
5. INSTALL TEMPORARY STEEL PLATE BEAM GUARDRAIL, TYPE A FROM STA. 680+00 - 683+00.
6. INSTALL IMPACT ATTENUATOR, TEMPORARY AT STA. 680+00 RT.
7. USE STANDARD 701201 TO CONSTRUCT DOWNSTREAM ENDS OF CULVERTS LOCATED AT STA. 626+61, STA. 635+63, STA. 654+30, STA. 659+22, AND STA. 667+20. (MAINTAIN EXISTING FLOW)
8. USE STANDARD 701201 TO CONSTRUCT UPSTREAM ENDS OF CULVERTS LOCATED AT STA. 626+61, STA. 635+63, STA. 654+30, STA. 659+22, AND STA. 667+20 AND ANY SIDE ROAD CULVERTS NECESSARY. (MAINTAIN EXISTING FLOW)
9. PLACE CLASS D PATCH FOR WORK AREAS (MATCH EXISTING PAVEMENT).
10. INSTALL TRAFFIC BARRIER TERMINALS FROM STA. 626+11 TO 627+11.

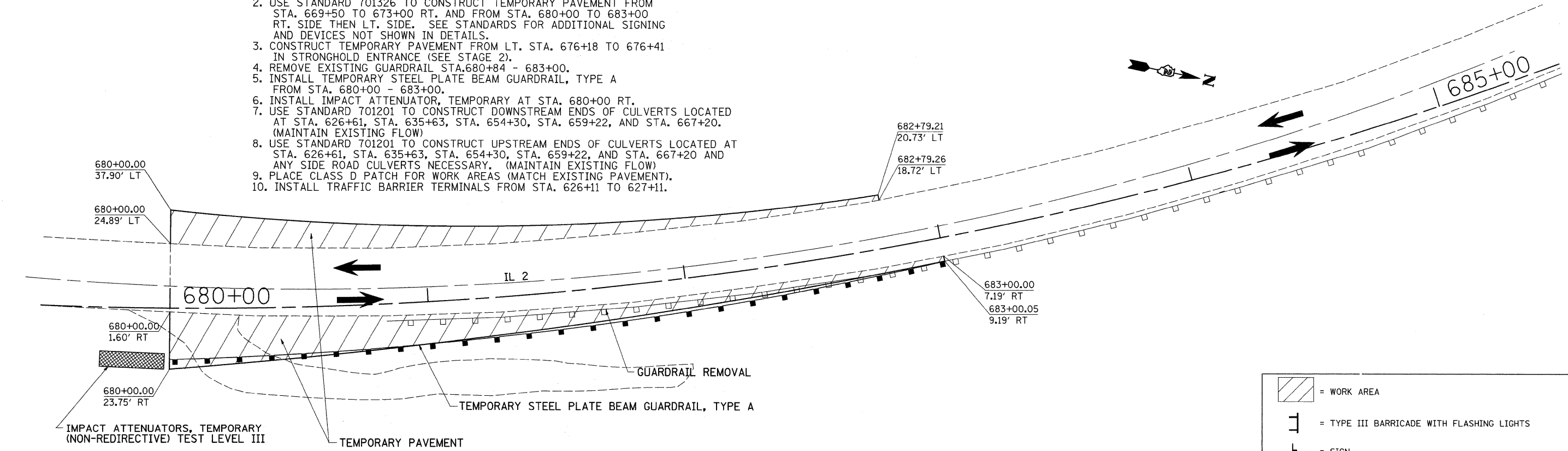

FILE NAME =	USER NAME = perknsdr	DESIGNED -	REVISED -	<b>STATE OF ILLINOIS DEPARTMENT OF TRANSPORTATION</b>	<b>STAGE 1</b>	F.A.P. RTE.	SECTION	COUNTY	TOTAL SHEETS	SHEET NO.	
ca:\pwork\pwork\perknsdr\dms34123\dms486stg69.dgn	486stg69.dgn	DRAWN -	REVISED -			742	37RS-3	OGLE	345	67	
PLOT SCALE = 20.0000' / IN.	CHECKED -	REVISED -	REVISED -			CONTRACT NO. 84788					
PLOT DATE = Fri Jun 05 14:07:26 2009	DATE -	REVISED -	REVISED -			ILLINOIS FED. AID PROJECT					



# STAGE 2

## STA. 673+00 - 680+00

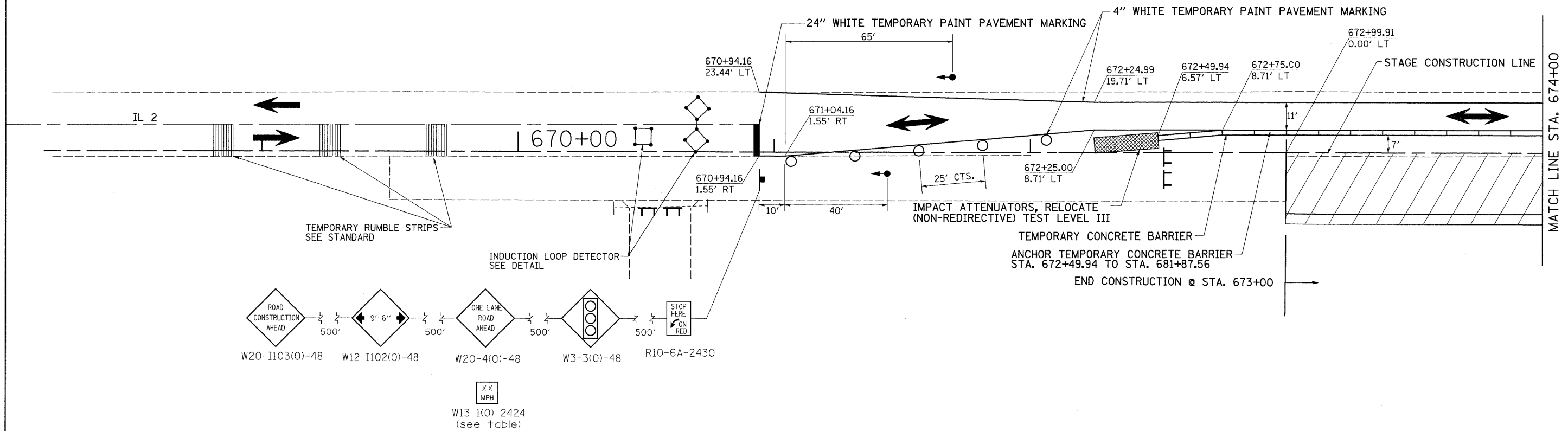

1. USE STANDARD 701321. SEE STANDARDS FOR ADDITIONAL SIGNING AND DEVICES NOT SHOWN IN DETAILS.
2. REMOVAL OF GUARDRAIL AT RT. STA. 677+19 TO 678+70.
3. REMOVAL OF EXISTING PAVEMENT FROM STA. 673+00 TO STA. 680+00 TO THE STAGE CONSTRUCTION LINE.
4. PLACE TEMPORARY SHEET PILING.
5. CONSTRUCT DOWNSTREAM END OF CAST-IN-PLACE DOUBLE 7' X 3' BOX CULVERT.
6. REMOVAL OF DOWNSTREAM PORTION OF EXISTING 12' X 3' BOX CULVERT, (MAINTAIN EXISTING FLOW).
7. CONSTRUCT SUB-BASE GRANULAR MATERIAL, TYPE A.
8. CONSTRUCT PCC PAVEMENT (JOINTED) & PCC SHOULDERS.
9. INSTALL STEEL PLATE BEAM GUARDRAIL, TYPE A AT RT. STA. 676+59 TO 680+00.
10. RELOCATE IMPACT ATTENUATOR FROM STA. 680+00 TO 672+50.
11. INSTALL IMPACT ATTENUATOR AT STA. 681+88.

	= WORK AREA
	= TYPE III BARRICADE WITH FLASHING LIGHTS
	= SIGN
	= BARRICADE, OR DRUM WITH STEADY BURNING LIGHTS
	= INDUCTION LOOP DETECTOR
	= TRAFFIC SIGNAL
	= TEMPORARY RUMBLE STRIPS

FILE NAME =	USER NAME = cushmanbw	DESIGNED -	REVISED -	<b>STATE OF ILLINOIS</b>	<b>STAGE 2</b>	F.A.P. RTE.	SECTION	COUNTY	TOTAL SHEETS	SHEET NO.
ct\pw_work\PWIDOT\CUSHMANBW\dms34123\dms34123.dwg	6486stg69.dgn	DRAWN -	REVISED -	<b>DEPARTMENT OF TRANSPORTATION</b>		742	37RS-3	OGLE	345	68
	PLOT SCALE = 20.0000' / IN.	CHECKED -	REVISED -						CONTRACT NO. 84788	
	PLOT DATE = Fri May 01 07:29:43 2009	DATE -	REVISED -		SCALE:	SHEET NO.	OF	SHEETS	STA.	TO STA.
									FED. ROAD DIST. NO.	ILLINOIS FED. AID PROJECT

# STAGE 2

## STA. 673+00 - 680+00

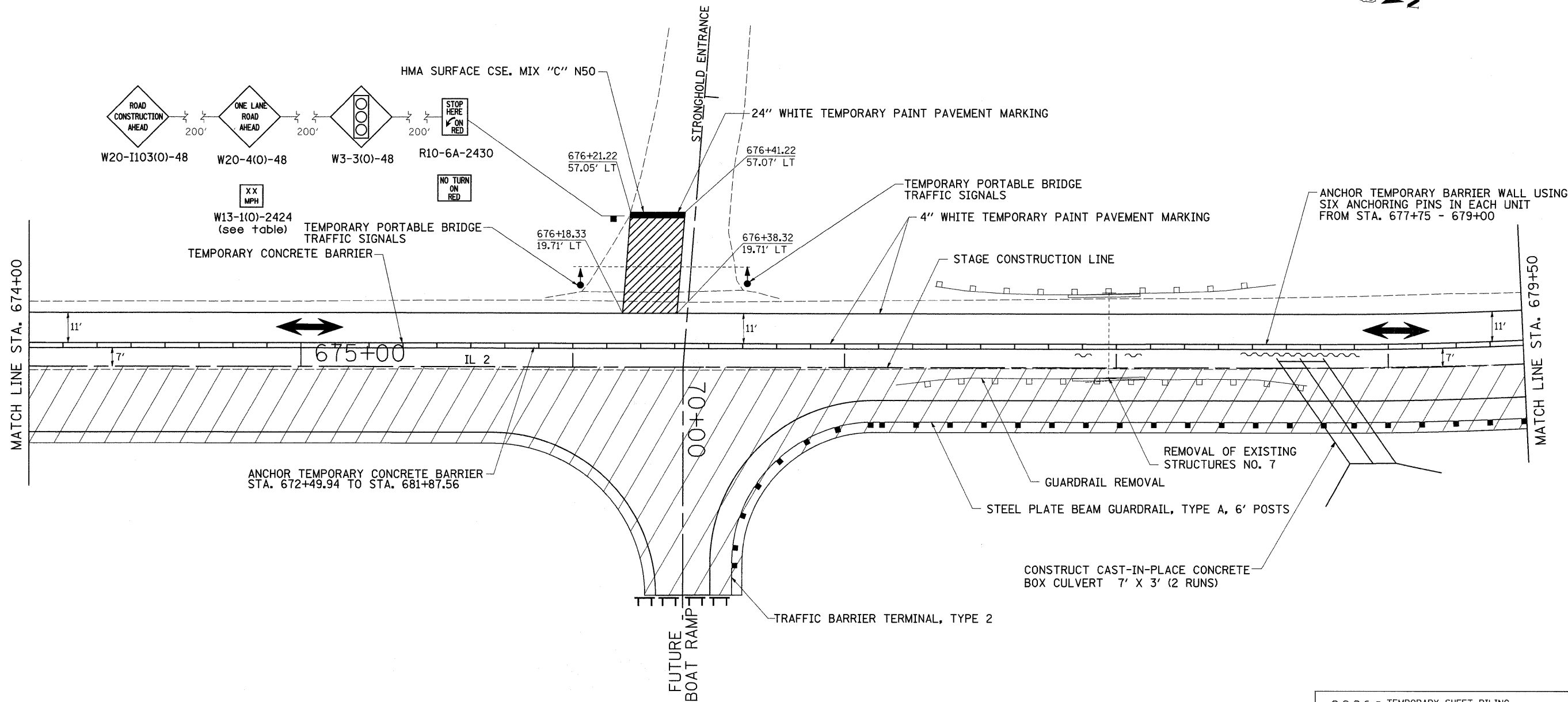

### STAGE 2 NOTES

1. USE STANDARD 701321. SEE STANDARDS FOR ADDITIONAL SIGNING AND DEVICES NOT SHOWN IN DETAILS.
2. REMOVAL OF GUARDRAIL AT RT. STA. 677+19 TO 678+70.
3. REMOVAL OF EXISTING PAVEMENT FROM STA. 673+00 TO STA. 680+00 TO THE STAGE CONSTRUCTION LINE.
4. PLACE TEMPORARY SHEET PILING.
5. CONSTRUCT DOWNSTREAM END OF CAST-IN-PLACE DOUBLE 7' X 3' BOX CULVERT.
6. REMOVAL OF DOWNSTREAM PORTION OF EXISTING 12' X 3' BOX CULVERT, (MAINTAIN EXISTING FLOW).
7. CONSTRUCT SUB-BASE GRANULAR MATERIAL, TYPE A.
8. CONSTRUCT PCC PAVEMENT (JOINTED) & PCC SHOULDERS.
9. INSTALL STEEL PLATE BEAM GUARDRAIL, TYPE A AT RT. STA. 676+59 TO 680+00.
10. RELOCATE IMPACT ATTENUATOR FROM STA. 680+00 TO 672+50.
11. INSTALL IMPACT ATTENUATOR AT STA. 681+88.

	= TEMPORARY SHEET PILING
	= WORK AREA
	= TYPE III BARRICADE WITH FLASHING LIGHTS
	= SIGN
	= BARRICADE, OR DRUM WITH STEADY BURNING LIGHTS
	= INDUCTION LOOP DETECTOR
	= TRAFFIC SIGNAL
	= TEMPORARY RUMBLE STRIPS

FILE NAME =	USER NAME = cushmanbw	DESIGNED -	REVISED -	<b>STATE OF ILLINOIS</b> <b>DEPARTMENT OF TRANSPORTATION</b>	<b>STAGE 2</b>	F.A.P. RTE.	SECTION	COUNTY	TOTAL SHEETS	SHEET NO.	
cs:\pw_work\PWIDOT\CUSHMANBW\dms34123\6496stg69.dgn		DRAWN -	REVISED -			742	37RS-3	OGLE	345	69	
PLOT SCALE = 20.0000' / IN.		CHECKED -	REVISED -			CONTRACT NO. 84788					
PLOT DATE = Fri May 01 07:29:56 2009		DATE -	REVISED -			FED. ROAD DIST. NO. ILLINOIS FED. AID PROJECT					

# STAGE 2

## STA. 673+00 - 680+00

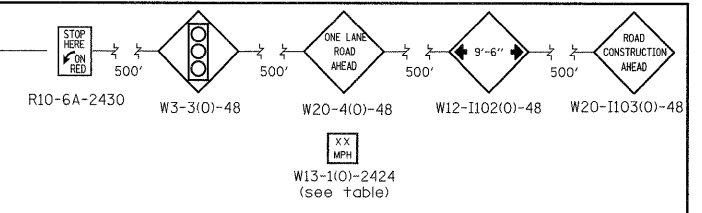
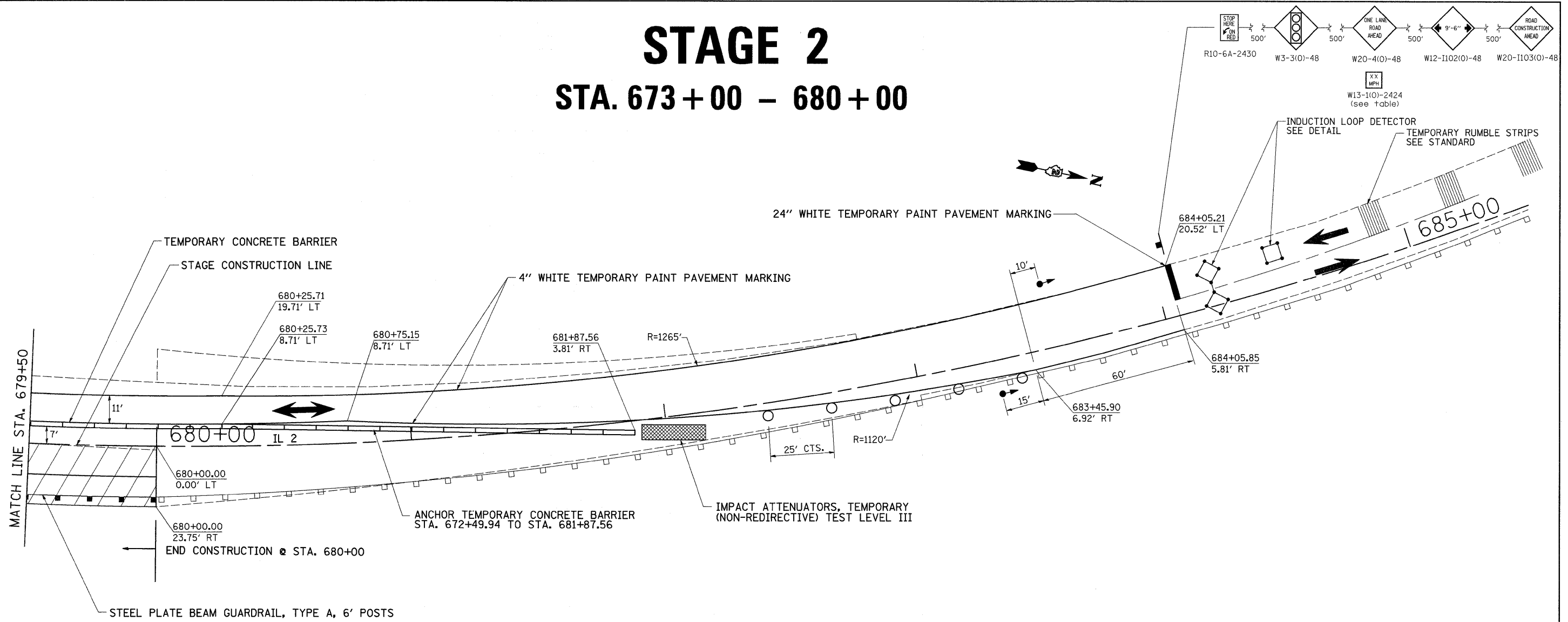

### STAGE 2 NOTES

1. USE STANDARD 701321. SEE STANDARDS FOR ADDITIONAL SIGNING AND DEVICES NOT SHOWN IN DETAILS.
2. REMOVAL OF GUARDRAIL AT RT. STA. 677+19 TO 678+70.
3. REMOVAL OF EXISTING PAVEMENT FROM STA. 673+00 TO STA. 680+00 TO THE STAGE CONSTRUCTION LINE.
4. PLACE TEMPORARY SHEET PILING.
5. CONSTRUCT DOWNSTREAM END OF CAST-IN-PLACE DOUBLE 7' X 3' BOX CULVERT.
6. REMOVAL OF DOWNSTREAM PORTION OF EXISTING 12' X 3' BOX CULVERT, (MAINTAIN EXISTING FLOW).
7. CONSTRUCT SUB-BASE GRANULAR MATERIAL, TYPE A.
8. CONSTRUCT PCC PAVEMENT (JOINTED) & PCC SHOULDERS.
9. INSTALL STEEL PLATE BEAM GUARDRAIL, TYPE A AT RT. STA. 676+59 TO 680+00.
10. RELOCATE IMPACT ATTENUATOR FROM STA. 680+00 TO 672+50.
11. INSTALL IMPACT ATTENUATOR AT STA. 681+88.

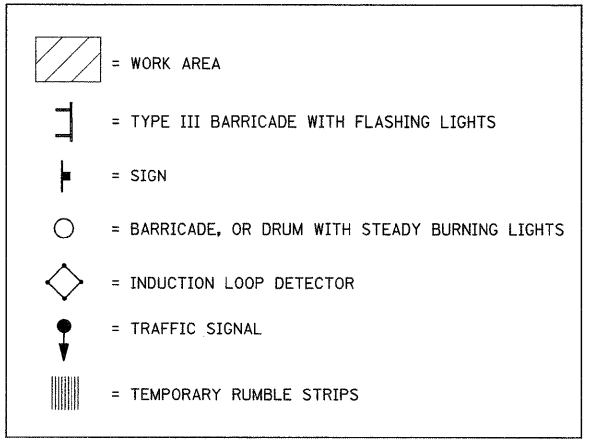

FILE NAME =	USER NAME = cushmanbw	DESIGNED -	REVISED -	<b>STATE OF ILLINOIS DEPARTMENT OF TRANSPORTATION</b>	<b>STAGE 2</b>	F.A.P. RTE. 742	SECTION 37RS-3	COUNTY OGLE	TOTAL SHEETS 345	SHEET NO. 70		
ci:\pw_work\PIWIDOT\CUSHMANBW\dms34123\6486atg69.dgn	PLOT SCALE = 20,0000' / IN.	DRAWN -	REVISED -			SCALE:	SHEET NO. OF SHEETS	STA. TO STA.	CONTRACT NO. 84788			
	PLOT DATE = Fri May 01 07:30:08 2009	CHECKED -	REVISED -									
		DATE -	REVISED -									

# STAGE 3

## STA. 673+00 - 680+00

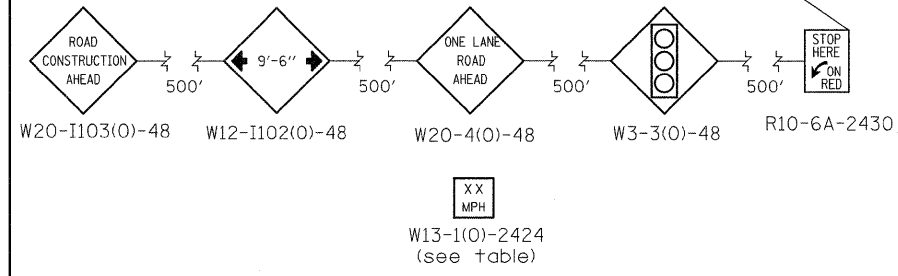
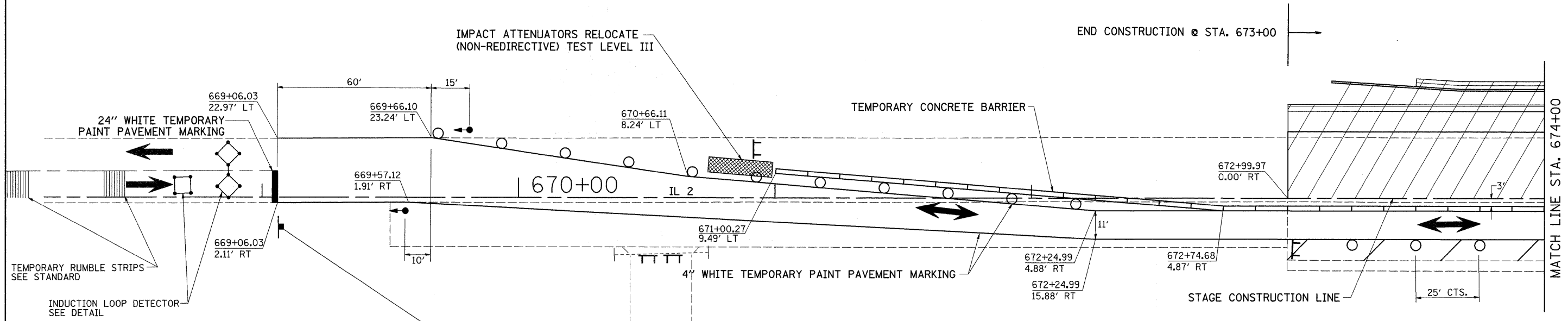

### STAGE 3 NOTES

1. USE STANDARD 701321. SEE STANDARDS FOR ADDITIONAL SIGNING AND DEVICES NOT SHOWN IN DETAILS.
2. REMOVAL OF GUARDRAIL @ LT STA. 677+34 TO 678+58.
3. CONSTRUCT UPSTREAM END OF CAST-IN-PLACE DOUBLE 7' X 3' BOX CULVERT.
4. REMOVAL OF REMAINING UPSTREAM PORTION OF EXISTING 12' X 3' BOX CULVERT.
5. CONSTRUCT SUB-BASE GRANULAR MATERIAL, TYPE A.
6. CONSTRUCT STORM SEWER, INLETS, COMBINATION CONCRETE CURB & GUTTER, RETAINING WALL AND TYPE A GUTTER.
7. CONSTRUCT PCC PAVEMENT (JOINTED) & PCC SHOULDERS.
8. CONSTRUCT TRANSITION AND BUTT JOINT FROM STA. 680+00 TO STA. 683+00.

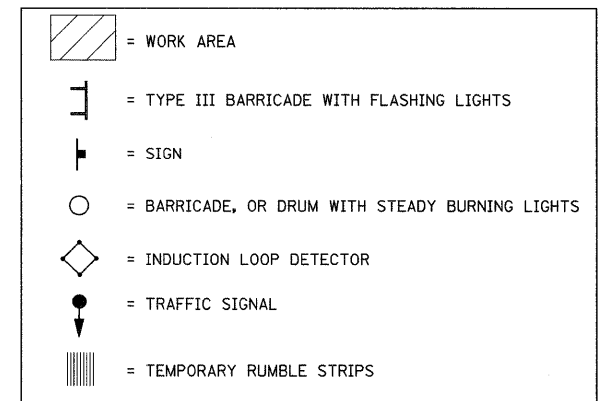

FILE NAME =	USER NAME = cushmanbw	DESIGNED -	REVISED -	<b>STATE OF ILLINOIS DEPARTMENT OF TRANSPORTATION</b>	<b>STAGE 3</b>	F.A.P. RTE. 742	SECTION 37RS-3	COUNTY OGLE	TOTAL SHEETS 345	SHEET NO. 71		
ci\pwork\PIWIDOT\CUSHMANBW\dms34123\6486stg69.dgn	6486stg69.dgn	DRAWN -	REVISED -			SCALE:	SHEET NO. OF SHEETS	STA. TO STA.	CONTRACT NO. 84788			
	PLOT SCALE = 20,0000' / IN.	CHECKED -	REVISED -						FED. ROAD DIST. NO. [ILLINOIS] FED. AID PROJECT			
	PLOT DATE = Fri May 01 07:30:19 2009	DATE -	REVISED -									

# STAGE 3

## STA. 673+00 - 680+00

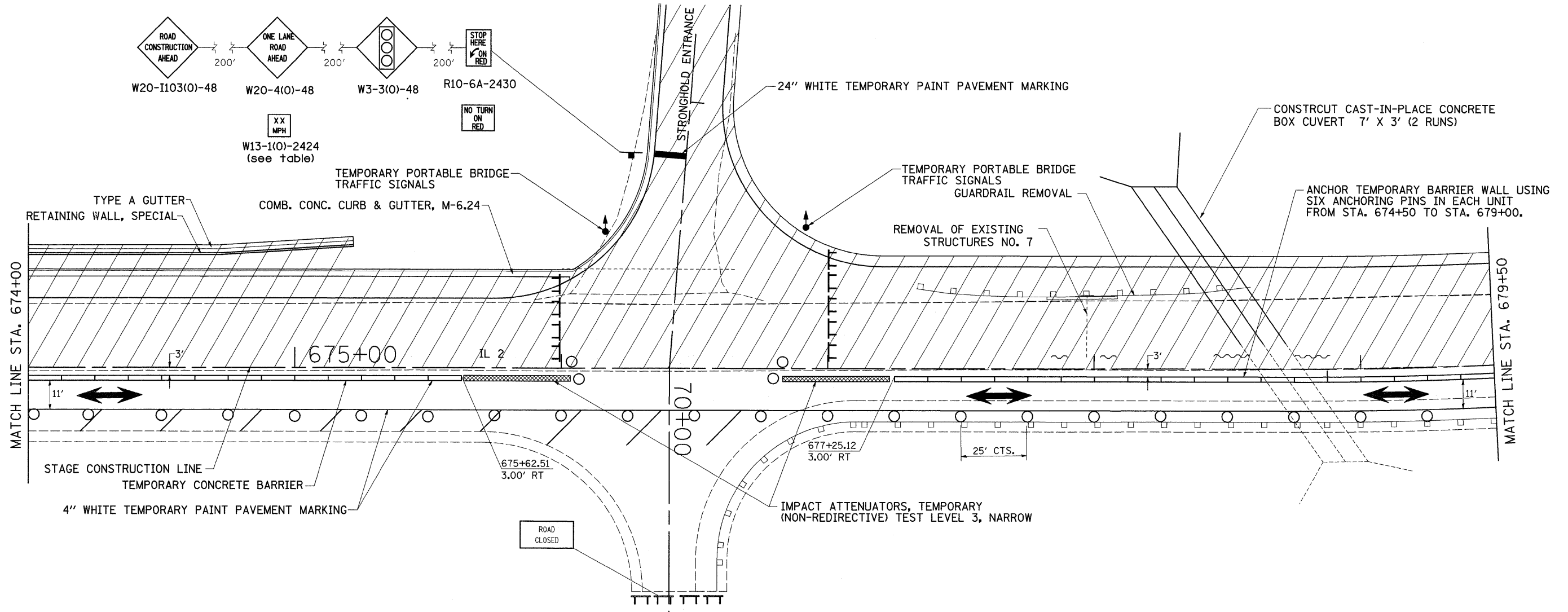

### STAGE 3 NOTES

1. USE STANDARD 701321. SEE STANDARDS FOR ADDITIONAL SIGNING AND DEVICES NOT SHOWN IN DETAILS.
2. REMOVAL OF GUARDRAIL @ LT STA. 677+34 TO 678+58.
3. CONSTRUCT UPSTREAM END OF CAST-IN-PLACE DOUBLE 7' X 3' BOX CULVERT.
4. REMOVAL OF REMAINING UPSTREAM PORTION OF EXISTING 12' X 3' BOX CULVERT.
5. CONSTRUCT SUB-BASE GRANULAR MATERIAL, TYPE A.
6. CONSTRUCT STORM SEWER, INLETS, COMBINATION CONCRETE CURB & GUTTER, RETAINING WALL AND TYPE A GUTTER.
7. CONSTRUCT PCC PAVEMENT (JOINTED) & PCC SHOULDERS.
8. CONSTRUCT TRANSITION AND BUTT JOINT FROM STA. 680+00 TO STA. 683+00.

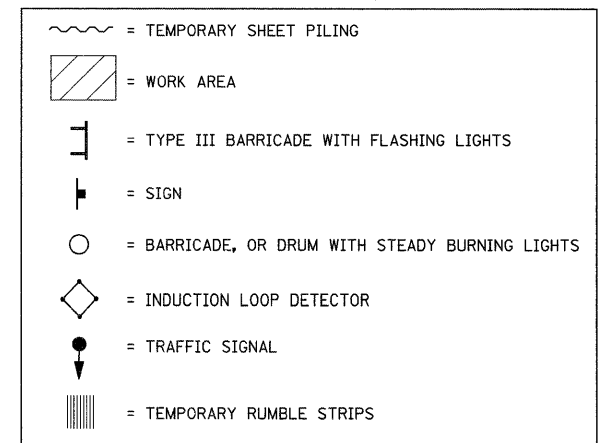

FILE NAME =	USER NAME = cushmanbw	DESIGNED -	REVISED -	<b>STATE OF ILLINOIS DEPARTMENT OF TRANSPORTATION</b>	<b>STAGE 3</b>	F.A.P. RTE.	SECTION	COUNTY	TOTAL SHEETS	SHEET NO.	
ci:\pw_work\PIWIDOT\CUSHMANBW\dms34123\6486atg69.dgn		DRAWN -	REVISED -			742	37RS-3	OGLE	345	72	
PLOT SCALE = 20,0000' / IN.		CHECKED -	REVISED -			CONTRACT NO. 84788					
PLOT DATE = Fri May 01 07:30:31 2009		DATE -	REVISED -			FED. ROAD DIST. NO. ILLINOIS FED. AID PROJECT					





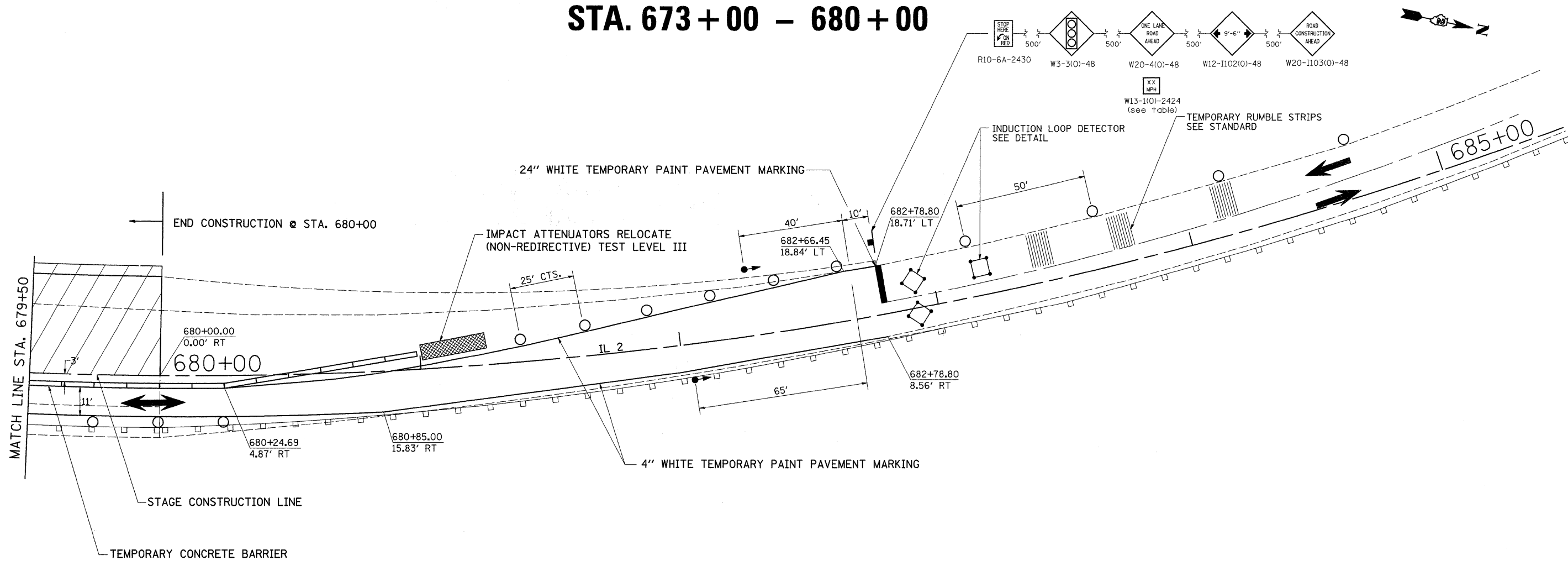

# STAGE 3

## STA. 673+00 - 680+00



### STAGE 3 NOTES

1. USE STANDARD 701321. SEE STANDARDS FOR ADDITIONAL SIGNING AND DEVICES NOT SHOWN IN DETAILS.
2. REMOVAL OF GUARDRAIL @ LT STA. 677+34 TO 678+58.
3. CONSTRUCT UPSTREAM END OF CAST-IN-PLACE DOUBLE 7' X 3' BOX CULVERT.
4. REMOVAL OF REMAINING UPSTREAM PORTION OF EXISTING 12' X 3' BOX CULVERT.
5. CONSTRUCT SUB-BASE GRANULAR MATERIAL, TYPE A.
6. CONSTRUCT STORM SEWER, INLETS, COMBINATION CONCRETE CURB & GUTTER, RETAINING WALL AND TYPE A GUTTER.
7. CONSTRUCT PCC PAVEMENT (JOINTED) & PCC SHOULDERS.
8. CONSTRUCT TRANSITION AND BUTT JOINT FROM STA. 680+00 TO STA. 683+00.

	= WORK ZONE
	= TYPE III BARRICADE WITH FLASHING LIGHTS
	= SIGN
	= BARRICADE, OR DRUM WITH STEADY BURNING LIGHTS
	= INDUCTION LOOP DETECTOR
	= TRAFFIC SIGNAL
	= TEMPORARY RUMBLE STRIPS

FILE NAME =	USER NAME = cushmanbw	DESIGNED -	REVISED -	<b>STATE OF ILLINOIS DEPARTMENT OF TRANSPORTATION</b>	<b>STAGE 3</b>	F.A.P. RTE. 742	SECTION 37RS-3	COUNTY OGLE	TOTAL SHEETS 345	SHEET NO. 73		
ci:\pw_work\PIWIDOT\CUSHMANBW\dms34123\6486atg69.dgn	PLOT SCALE = 20.0000" / IN.	DRAWN -	REVISED -			SCALE:	SHEET NO. OF SHEETS	STA. TO STA.	CONTRACT NO. 84788			
	PLOT DATE = Fri May 01 07:30:44 2009	CHECKED -	REVISED -									
		DATE -	REVISED -									

# STAGE 3

STA. 673 + 00 - 680 + 00

## TEMPORARY PAVEMENT MARKING LAYOUT ON SOUTH SIDE OF COMPLETED STAGE 3

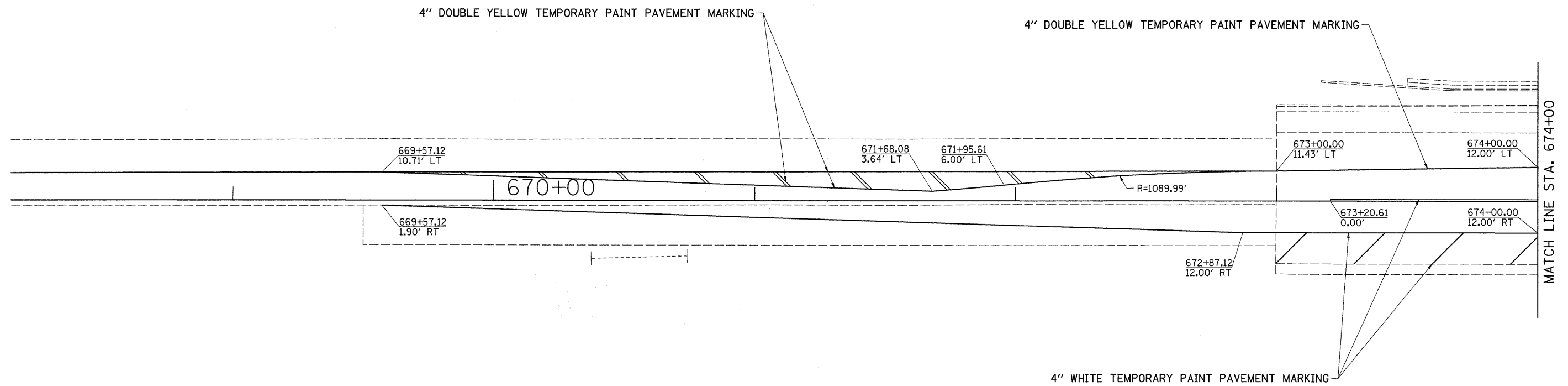
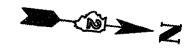

**SEE PAVEMENT MARKING SHEETS FOR TEMPORARY PAVEMENT  
MARKING LAYOUT ON NORTH SIDE OF COMPLETED STAGE 3**

FILE NAME =	USER NAME = oushmanbw	DESIGNED -	REVISED -	<b>STATE OF ILLINOIS DEPARTMENT OF TRANSPORTATION</b>	<b>STAGE 3</b>			F.A.P. RTE. 742	SECTION 37RS-3	COUNTY OGLE	TOTAL SHEETS 345	SHEET NO. 74
ct:\pwwork\pwwid\DOT\CUSHMANBW\dms34123\6486atg69.dgn	PLOT SCALE = 20,0000' / IN.	DRAWN -	REVISED -					SCALE:	SHEET NO.	OF SHEETS	STA.	TO STA.
	PLOT DATE = Fri May 01 07:30:58 2009	CHECKED -	REVISED -									
		DATE -	REVISED -									

# STAGE 4

## STA. 603+08 - 611+00

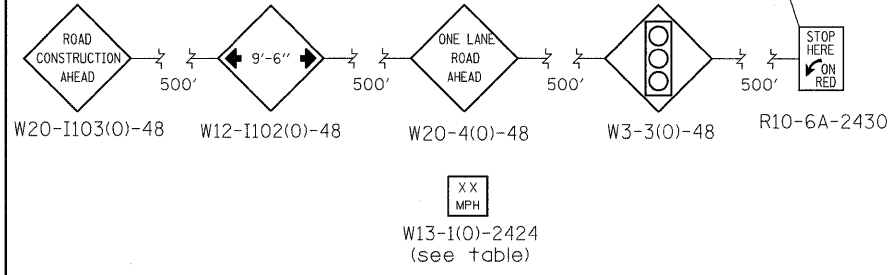
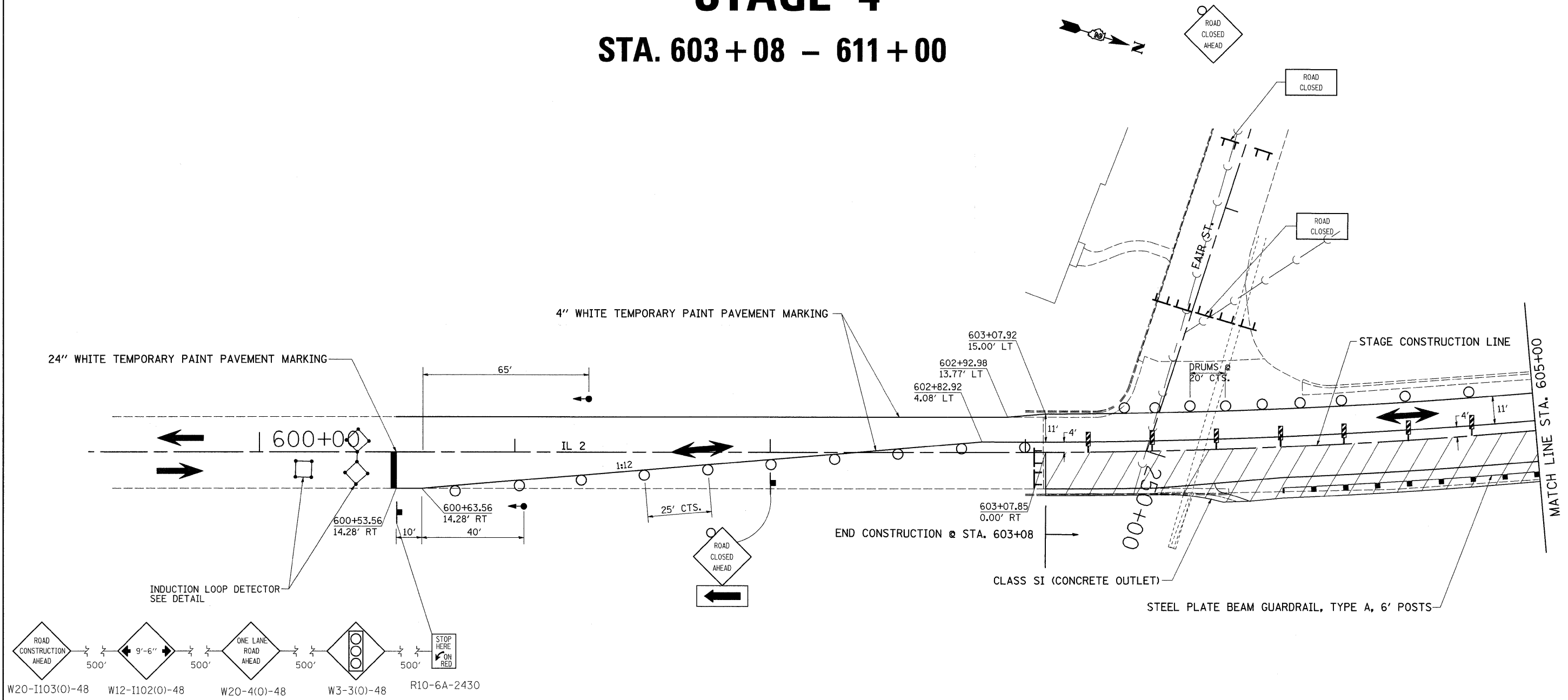

### STAGE 4 NOTES

1. USE STANDARD 701316. SEE STANDARDS FOR ADDITIONAL SIGNING AND DEVICES NOT SHOWN IN DETAILS.
2. CLOSE SIDEROAD "FAIR ST." AS SHOWN.
3. REMOVAL OF EXISTING PAVEMENT FROM STA. 603+08 TO STA. 611+00 TO THE STAGE CONSTRUCTION LINE.
4. CONSTRUCT SUB-BASE GRANULAR MATERIAL, TYPE "A."
5. CONSTRUCT COMBINATION CONCRETE CURB AND GUTTER AND CLASS SI CONCRETE OUTLET.
6. CONSTRUCT PCC PAVEMENT (JOINTED) & PCC SHOULDERS.
7. INSTALL STEEL PLATE BEAM GUARDRAIL, TYPE A, 6' POSTS AT STA. 604+50 TO 608+50 RT.
8. INSTALL TRAFFIC BARRIER TERMINAL, TYPE 1 (SPECIAL) TANGENT AT STA. 604+00 TO 604+50 RT.
9. RELOCATE IMPACT ATTENUATOR, TEMPORARY FROM 675+63 TO 608+50 RT.

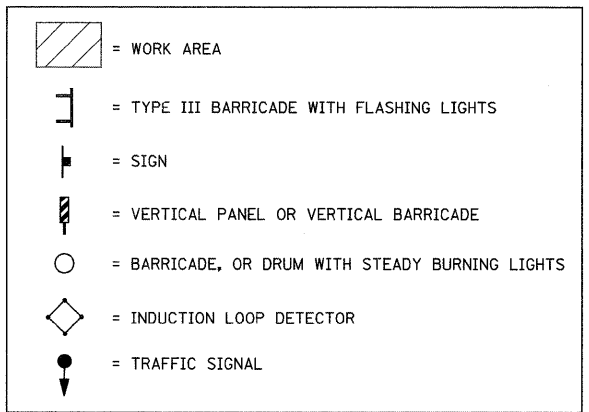

FILE NAME =	USER NAME = cushmanbw	DESIGNED -	REVISED -	<b>STATE OF ILLINOIS DEPARTMENT OF TRANSPORTATION</b>	<b>STAGE 4</b>	F.A.P. RTE. 742	SECTION 37RS-3	COUNTY OGLE	TOTAL SHEETS 345	SHEET NO. 75		
ci:\pwork\PWIDOT\CUSHMANBW\dms34123\6486stg69.dgn	PLOT SCALE = 20,0000' / IN.	DRAWN -	REVISED -			SCALE:	SHEET NO. OF SHEETS STA. TO STA.	CONTRACT NO. 84788				
PLOT DATE = Fri May 01 07:31:26 2009	DATE -	CHECKED -	REVISED -			FED. ROAD DIST. NO. [ILLINOIS] FED. AID PROJECT						
		DATE -	REVISED -									



# STAGE 4

STA. 603+08 - 611+00

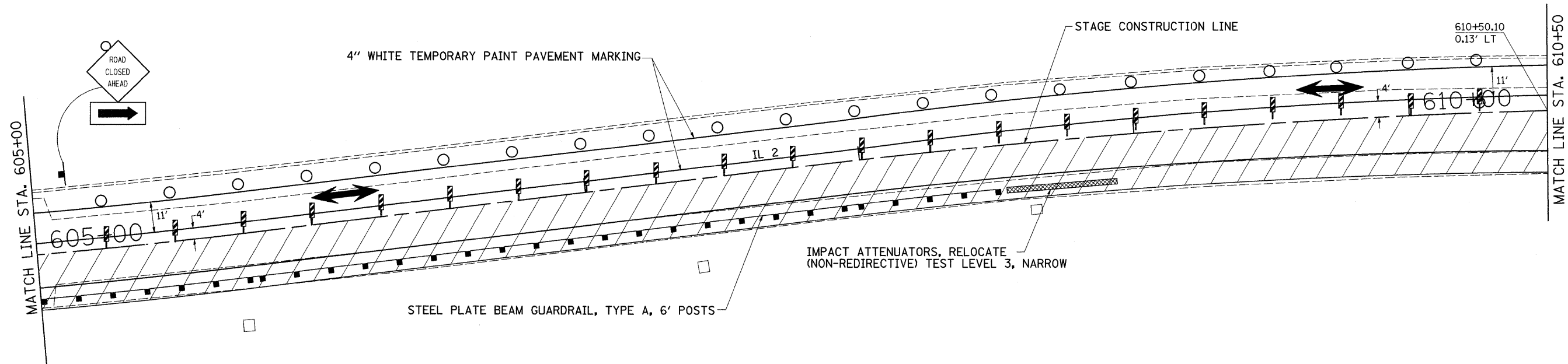

### STAGE 4 NOTES

1. USE STANDARD 701316. SEE STANDARDS FOR ADDITIONAL SIGNING AND DEVICES NOT SHOWN IN DETAILS.
2. CLOSE SIDEROAD "FAIR ST." AS SHOWN.
3. REMOVAL OF EXISTING PAVEMENT FROM STA. 603+08 TO STA. 611+00 TO THE STAGE CONSTRUCTION LINE.
4. CONSTRUCT SUB-BASE GRANULAR MATERIAL, TYPE "A."
5. CONSTRUCT COMBINATION CONCRETE CURB AND GUTTER AND CLASS SI CONCRETE OUTLET.
6. CONSTRUCT PCC PAVEMENT (JOINTED) & PCC SHOULDERS.
7. INSTALL STEEL PLATE BEAM GUARDRAIL, TYPE A, 6' POSTS AT STA. 604+50 TO 608+50 RT.
8. INSTALL TRAFFIC BARRIER TERMINAL, TYPE 1 (SPECIAL) TANGENT AT STA. 604+00 TO 604+50 RT.
9. RELOCATE IMPACT ATTENUATOR, TEMPORARY FROM 675+63 TO 608+50 RT.

	= WORK AREA
	= TYPE III BARRICADE WITH FLASHING LIGHTS
	= SIGN
	= VERTICAL PANEL OR VERTICAL BARRICADE
	= BARRICADE, OR DRUM WITH STEADY BURNING LIGHTS
	= INDUCTION LOOP DETECTOR
	= TRAFFIC SIGNAL

FILE NAME =	USER NAME = cushmanbw	DESIGNED -	REVISED -
ct:\pw_work\VP\IDOT\CUSHMANBW\dms34123\dms34123\6486stg69.dgn		DRAWN -	REVISED -
PLOT SCALE = 20,0000' / IN.		CHECKED -	REVISED -
PLOT DATE = Fri May 01 07:31:39 2009		DATE -	REVISED -

STATE OF ILLINOIS  
DEPARTMENT OF TRANSPORTATION

## STAGE 4

SCALE: SHEET NO. OF SHEETS STA. TO STA.

F.A.P. RTE.	SECTION	COUNTY	TOTAL SHEETS	SHEET NO.
742	37RS-3	OGLE	345	76
FED. ROAD DIST. NO. ILLINOIS FED. AID PROJECT			CONTRACT NO. 84788	

# STAGE 4

## STA. 603+08 - 611+00

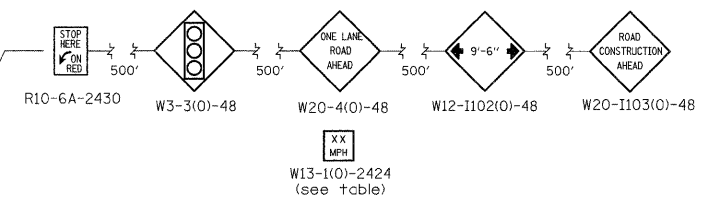
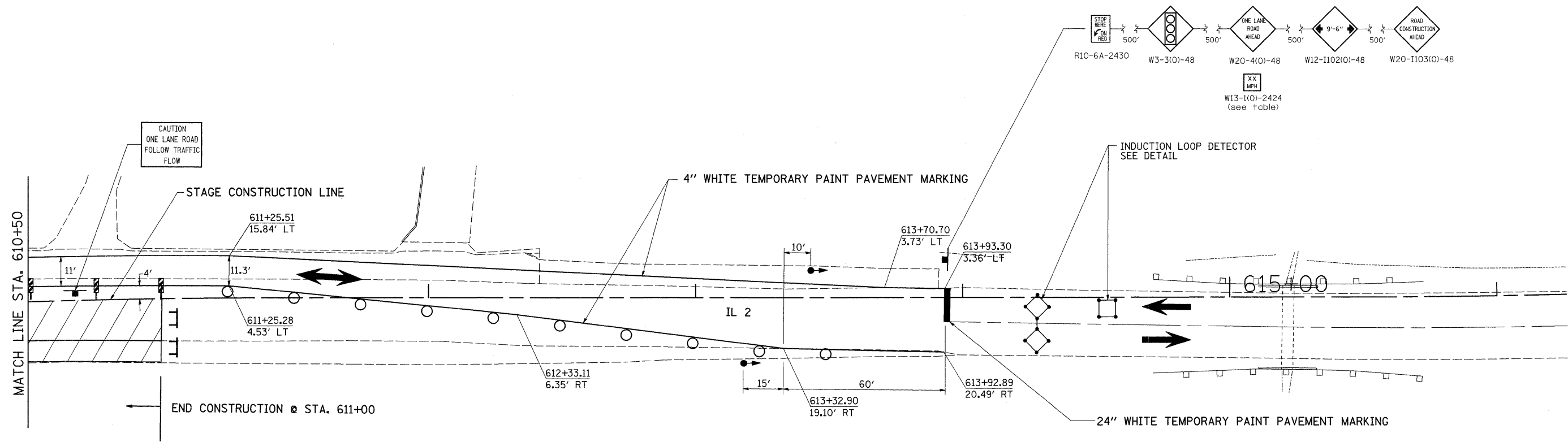

### STAGE 4 NOTES

1. USE STANDARD 701316. SEE STANDARDS FOR ADDITIONAL SIGNING AND DEVICES NOT SHOWN IN DETAILS.
2. CLOSE SIDEROAD "FAIR ST." AS SHOWN.
3. REMOVAL OF EXISTING PAVEMENT FROM STA. 603+08 TO STA. 611+00 TO THE STAGE CONSTRUCTION LINE.
4. CONSTRUCT SUB-BASE GRANULAR MATERIAL, TYPE "A."
5. CONSTRUCT COMBINATION CONCRETE CURB AND GUTTER AND CLASS SI CONCRETE OUTLET.
6. CONSTRUCT PCC PAVEMENT (JOINTED) & PCC SHOULDERS.
7. INSTALL STEEL PLATE BEAM GUARDRAIL, TYPE A, 6' POSTS AT STA. 604+50 TO 608+50 RT.
8. INSTALL TRAFFIC BARRIER TERMINAL, TYPE 1 (SPECIAL) TANGENT AT STA. 604+00 TO 604+50 RT.
9. RELOCATE IMPACT ATTENUATOR, TEMPORARY FROM 675+63 TO 608+50 RT.

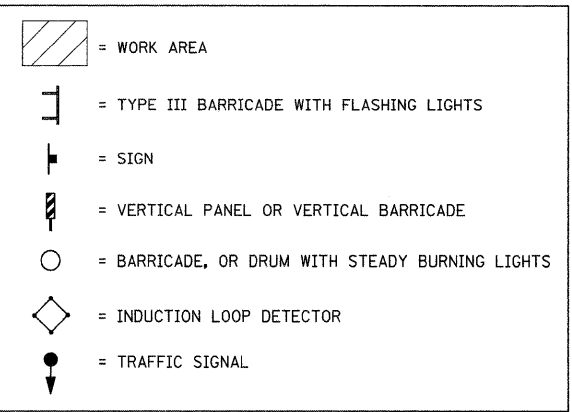

FILE NAME =	USER NAME = cushmanbw	DESIGNED -	REVISED -	<b>STATE OF ILLINOIS DEPARTMENT OF TRANSPORTATION</b>	<b>STAGE 4</b>	F.A.P. RTE.	SECTION	COUNTY	TOTAL SHEETS	SHEET NO.	
cr\pw_work\PWIDOT\CUSHMANBW\dss34123\06486stg69.dgn	6486stg69.dgn	DRAWN -	REVISED -			742	37RS-3	OGLE	345	77	
PLOT SCALE = 28.0000' / IN.	CHECKED -	REVISED -	REVISED -			CONTRACT NO. 84788					
PLOT DATE = Fri May 01 07:31:59 2009	DATE -	REVISED -	REVISED -			FED. ROAD DIST. NO. ILLINOIS FED. AID PROJECT					

# STAGE 5

## STA. 603+08 - 611+00

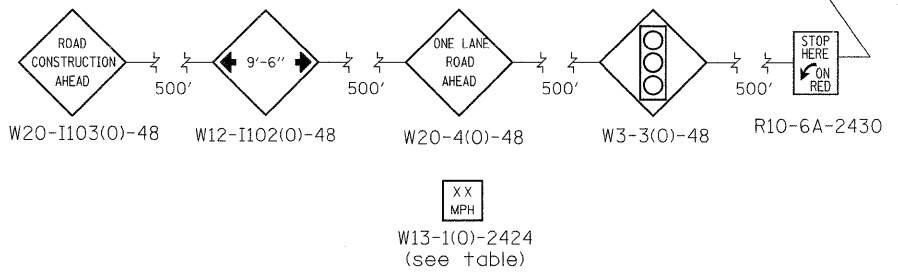
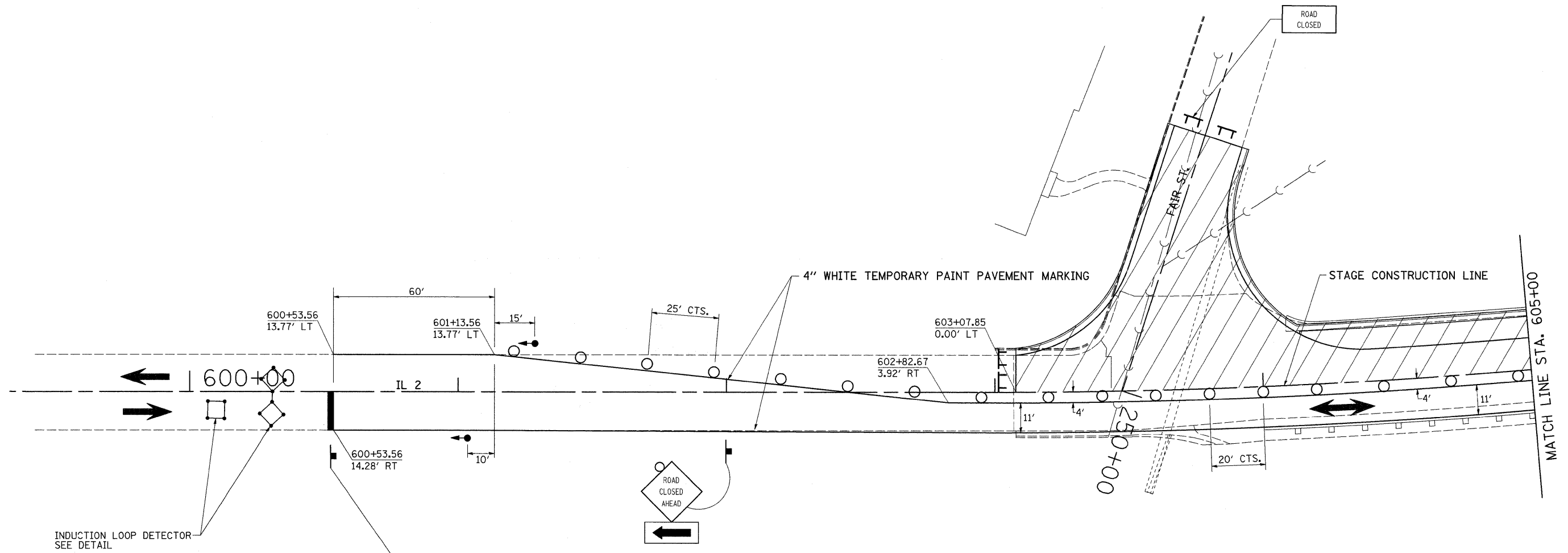

### STAGE 5 NOTES

1. USE STANDARD 701316. SEE STANDARDS FOR ADDITIONAL SIGNING AND DEVICES NOT SHOWN IN DETAILS.
2. CLOSE SIDEROAD "FAIR ST."
3. REMOVAL OF EXISTING PAVEMENT FROM STA. 603+08 TO STA. 611+00 TO THE STAGE CONSTRUCTION LINE.
4. CONSTRUCT SUB-BASE GRANULAR MATERIAL, TYPE "A."
5. CONSTRUCT STORM SEWER, INLETS, AND COMBINATION CONCRETE CURB & GUTTER.
6. CONSTRUCT PCC PAVEMENT (JOINTED) & PCC SHOULDERS.

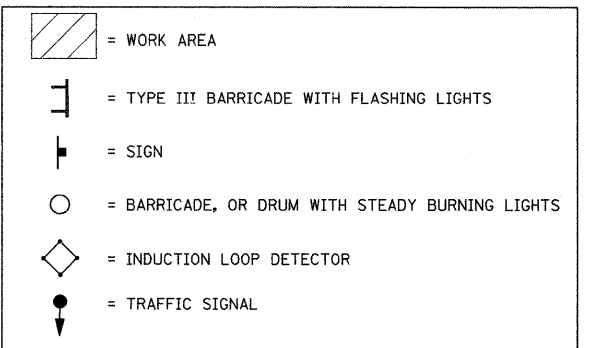

FILE NAME =	USER NAME = cushmanbw	DESIGNED -	REVISED -	<b>STATE OF ILLINOIS DEPARTMENT OF TRANSPORTATION</b>	<b>STAGE 5</b>	F.A.P. RTE.	SECTION	COUNTY	TOTAL SHEETS	SHEET NO.	
ct\pw_work\PWIDOT\CUSHMANBW\dms34123\6486stg69.dgn	6486stg69.dgn	DRAWN -	REVISED -			742	37RS-3	OGLE	345	78	
PLOT SCALE = 20.0000' / IN.		CHECKED -	REVISED -			CONTRACT NO. 84788					
PLOT DATE = Fri May 01 07:32:12 2009		DATE -	REVISED -			FED. ROAD DIST. NO. ILLINOIS FED. AID PROJECT					

# STAGE 5

STA. 603 + 08 - 611 + 00

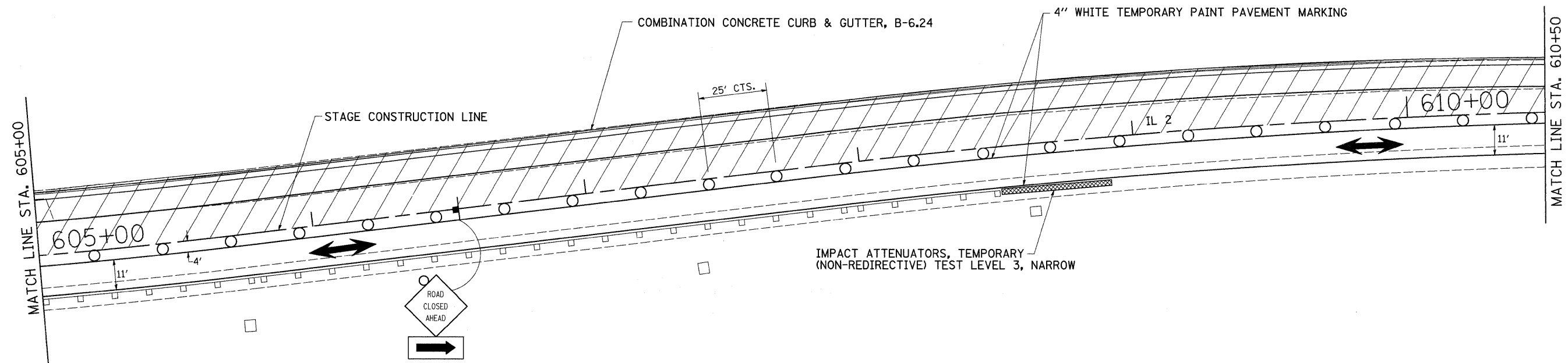

### STAGE 5 NOTES

1. USE STANDARD 701316. SEE STANDARDS FOR ADDITIONAL SIGNING AND DEVICES NOT SHOWN IN DETAILS.
2. CLOSE SIDEROAD "FAIR ST."
3. REMOVAL OF EXISTING PAVEMENT FROM STA. 603+08 TO STA. 611+00 TO THE STAGE CONSTRUCTION LINE.
4. CONSTRUCT SUB-BASE GRANULAR MATERIAL, TYPE "A."
5. CONSTRUCT STORM SEWER, INLETS, AND COMBINATION CONCRETE CURB & GUTTER.
6. CONSTRUCT PCC PAVEMENT (JOINTED) & PCC SHOULDERS.

	= WORK AREA
	= TYPE III BARRICADE WITH FLASHING LIGHTS
	= SIGN
	= BARRICADE, OR DRUM WITH STEADY BURNING LIGHTS
	= INDUCTION LOOP DETECTOR
	= TRAFFIC SIGNAL

FILE NAME =	USER NAME = cushmanbw	DESIGNED -	REVISED -
c:\pw_work\PW\DOT\CUSHMANBW\dms34123\06488stg69.dgn		DRAWN -	REVISED -
		CHECKED -	REVISED -
		DATE -	REVISED -

STATE OF ILLINOIS  
DEPARTMENT OF TRANSPORTATION

## STAGE 5

SCALE: SHEET NO. OF SHEETS STA. TO STA.

F.A.P. RTE.	SECTION	COUNTY	TOTAL SHEETS	SHEET NO.
742	37RS-3	OGLE	345	79
CONTRACT NO. 84788				
FED. ROAD DIST. NO. ILLINOIS FED. AID PROJECT				

# STAGE 5

STA. 603+08 - 611+00

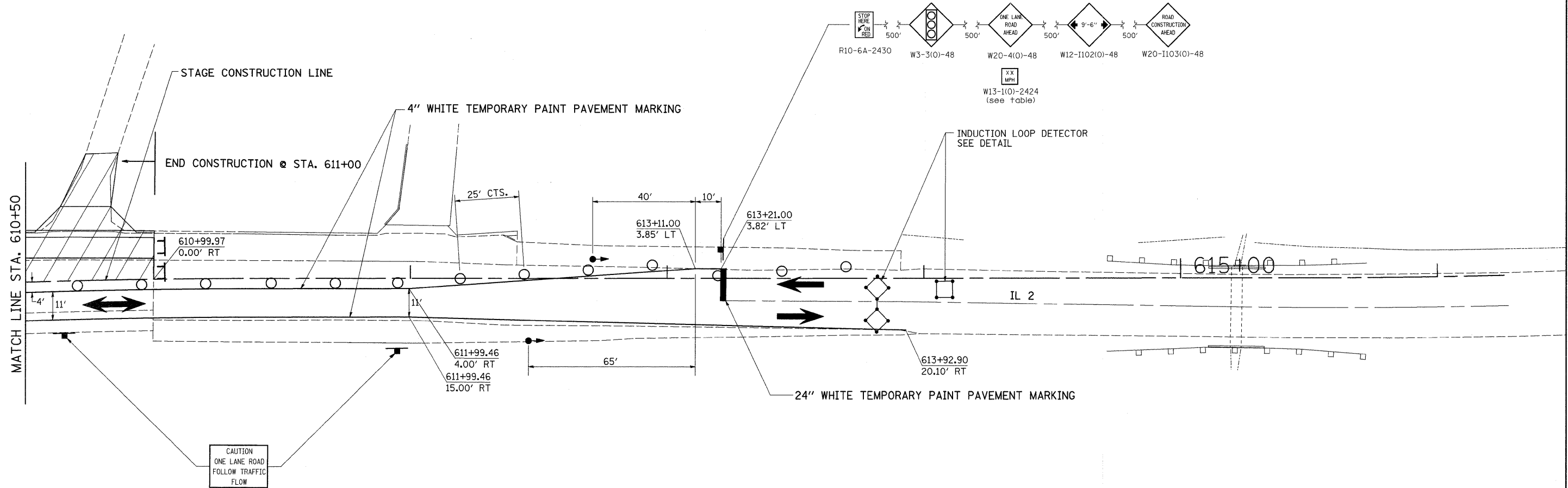

### STAGE 5 NOTES

1. USE STANDARD 701316. SEE STANDARDS FOR ADDITIONAL SIGNING AND DEVICES NOT SHOWN IN DETAILS.
2. CLOSE SIDEROAD "FAIR ST."
3. REMOVAL OF EXISTING PAVEMENT FROM STA. 603+08 TO STA. 611+00 TO THE STAGE CONSTRUCTION LINE.
4. CONSTRUCT SUB-BASE GRANULAR MATERIAL, TYPE "A."
5. CONSTRUCT STORM SEWER, INLETS, AND COMBINATION CONCRETE CURB & GUTTER.
6. CONSTRUCT PCC PAVEMENT (JOINTED) & PCC SHOULDERS.

	= WORK AREA
	= TYPE III BARRICADE WITH FLASHING LIGHTS
	= SIGN
	= BARRICADE, OR DRUM WITH STEADY BURNING LIGHTS
	= INDUCTION LOOP DETECTOR
	= TRAFFIC SIGNAL

FILE NAME =	USER NAME = cushmanbw	DESIGNED -	REVISED -
c:\pw_work\PWIDOT\CUSHMANBW\dms34123\06485stg69.dgn		DRAWN -	REVISED -
	PLOT SCALE = 20.0000' / IN.	CHECKED -	REVISED -
	PLOT DATE = Fri May 01 07:32:36 2009	DATE -	REVISED -

STATE OF ILLINOIS  
DEPARTMENT OF TRANSPORTATION

## STAGE 5

SCALE: SHEET NO. OF SHEETS STA. TO STA.

F.A.P. RTE.	SECTION	COUNTY	TOTAL SHEETS	SHEET NO.
742	37RS-3	OGLE	345	80
CONTRACT NO. 84788				
FED. ROAD DIST. NO. ILLINOIS FED. AID PROJECT				

# STAGE 6

## STA. 611+00 - 618+00

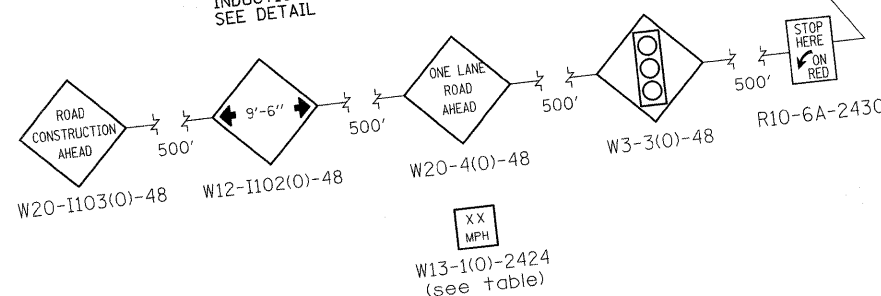
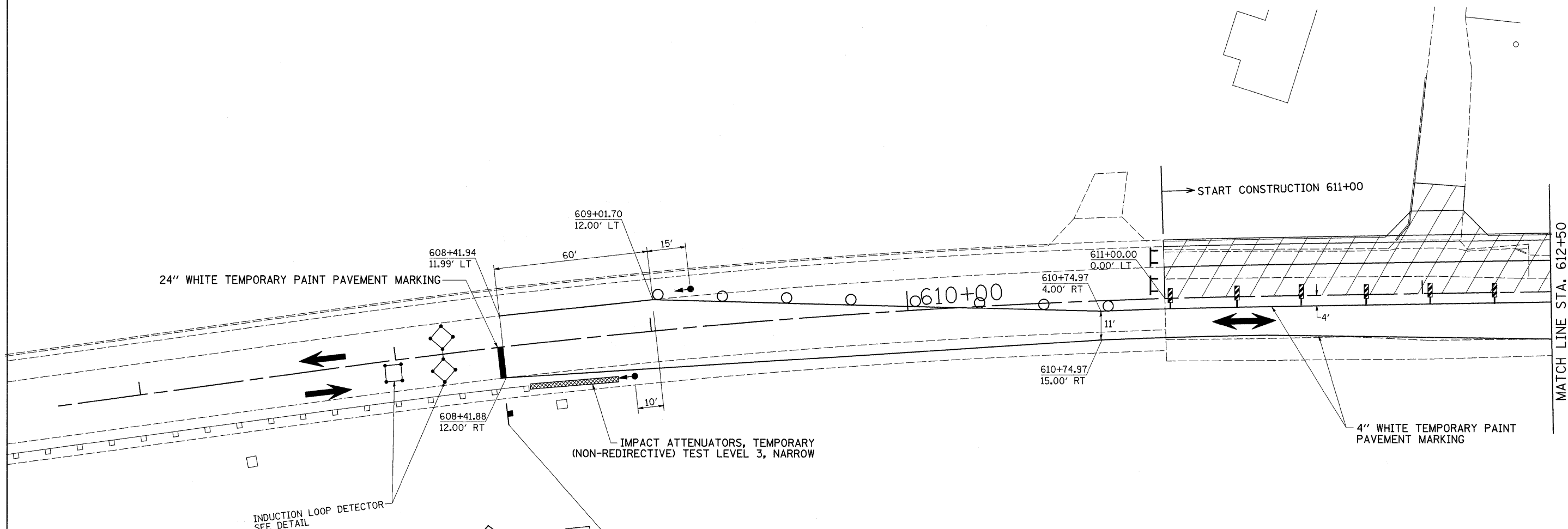

### STAGE 6 NOTES

1. USE STANDARD 701321. SEE STANDARDS FOR ADDITIONAL SIGNING AND DEVICES NOT SHOWN IN DETAILS.
2. REMOVAL OF EXISTING PAVEMENT FROM STA. 611+00 TO 618+00.
3. PLACE TEMPORARY SHEET PILING.
4. REMOVAL OF UPSTREAM PORTION OF EXISTING 4' X 4' BOX CULVERT. (MAINTAIN EXISTING FLOW.)
5. CONSTRUCT UPSTREAM END OF PRECAST DOUBLE 6' X 3' BOX CULVERT AT STA. 615+22.
6. CONSTRUCT SUB-BASE GRANULAR MATERIAL TYPE A.
7. CONSTRUCT COMBINATION CONCRETE CURB & GUTTER AND CLASS SI CONCRETE (OUTLET).
8. CONSTRUCT PCC PAVEMENT (JOINTED) & PCC SHOULDERS.
9. USE STANDARD 701326 TO CONSTRUCT TEMPORARY PAVEMENT FROM STA. 618+00 TO 619+77 LT.

	= WORK AREA
	= TYPE III BARRICADE WITH FLASHING LIGHTS
	= SIGN
	= VERTICAL PANEL OR VERTICAL BARRICADE
	= BARRICADE, OR DRUM WITH STEADY BURNING LIGHTS
	= INDUCTION LOOP DETECTOR
	= TRAFFIC SIGNAL

FILE NAME =	USER NAME = cushmanbw	DESIGNED -	REVISED -	<b>STATE OF ILLINOIS DEPARTMENT OF TRANSPORTATION</b>	<b>STAGE 6</b>	F.A.P. RTE.	SECTION	COUNTY	TOTAL SHEETS	SHEET NO.	
ct\pw_work\PWIDOT\CUSHMANBW\dms34123\0648stg6.dgn	PLOT SCALE = 20.0000' / IN.	DRAWN -	REVISED -			742	37RS-3	OGLE	345	81	
PLOT DATE = Fri May 01 07:32:56 2009	DATE -	CHECKED -	REVISED -			CONTRACT NO. 84788					
						ILLINOIS FED. AID PROJECT					

# STAGE 6

STA. 611+00 - 618+00

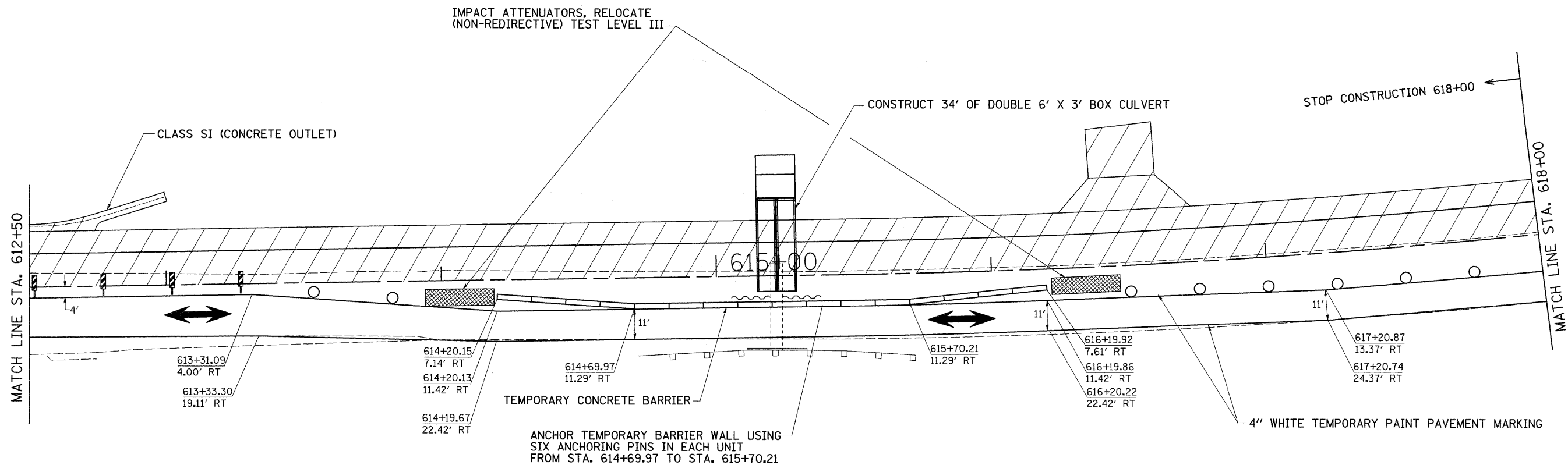

## STAGE 6 NOTES

1. USE STANDARD 701321. SEE STANDARDS FOR ADDITIONAL SIGNING AND DEVICES NOT SHOWN IN DETAILS.
2. REMOVAL OF EXISTING PAVEMENT FROM STA. 611+00 TO 618+00.
3. PLACE TEMPORARY SHEET PILING.
4. REMOVAL OF UPSTREAM PORTION OF EXISTING 4' X 4' BOX CULVERT. (MAINTAIN EXISTING FLOW.)
5. CONSTRUCT UPSTREAM END OF PRECAST DOUBLE 6' X 3' BOX CULVERT AT STA. 615+22.
6. CONSTRUCT SUB-BASE GRANULAR MATERIAL TYPE A.
7. CONSTRUCT COMBINATION CONCRETE CURB & GUTTER AND CLASS SI CONCRETE (OUTLET).
8. CONSTRUCT PCC PAVEMENT (JOINTED) & PCC SHOULDERS.
9. USE STANDARD 701326 TO CONSTRUCT TEMPORARY PAVEMENT FROM STA. 618+00 TO 619+77 LT.

	= TEMPORARY SHEET PILING
	= WORK AREA
	= TYPE III BARRICADE WITH FLASHING LIGHTS
	= SIGN
	= VERTICAL PANEL OR VERTICAL BARRICADE
	= BARRICADE, OR DRUM WITH STEADY BURNING LIGHTS
	= INDUCTION LOOP DETECTOR
	= TRAFFIC SIGNAL

FILE NAME =	USER NAME = cushmanbw	DESIGNED -	REVISED -	<b>STATE OF ILLINOIS DEPARTMENT OF TRANSPORTATION</b>	<b>STAGE 6</b>	F.A.P. RTE.	SECTION	COUNTY	TOTAL SHEETS	SHEET NO.	
ct\pw_work\PWIDOT\CUSHMANBW\dms34123\65486stg69.dgn		DRAWN -	REVISED -			742	37RS-3	OGLE	345	82	
PLOT SCALE = 28.0000' / IN.		CHECKED -	REVISED -			CONTRACT NO. 84788					
PLOT DATE = Fri May 01 07:33:11 2009		DATE -	REVISED -			SCALE:	SHEET NO.	OF	SHEETS	STA.	TO STA.

# STAGE 6

## STA. 611 + 00 - 618 + 00

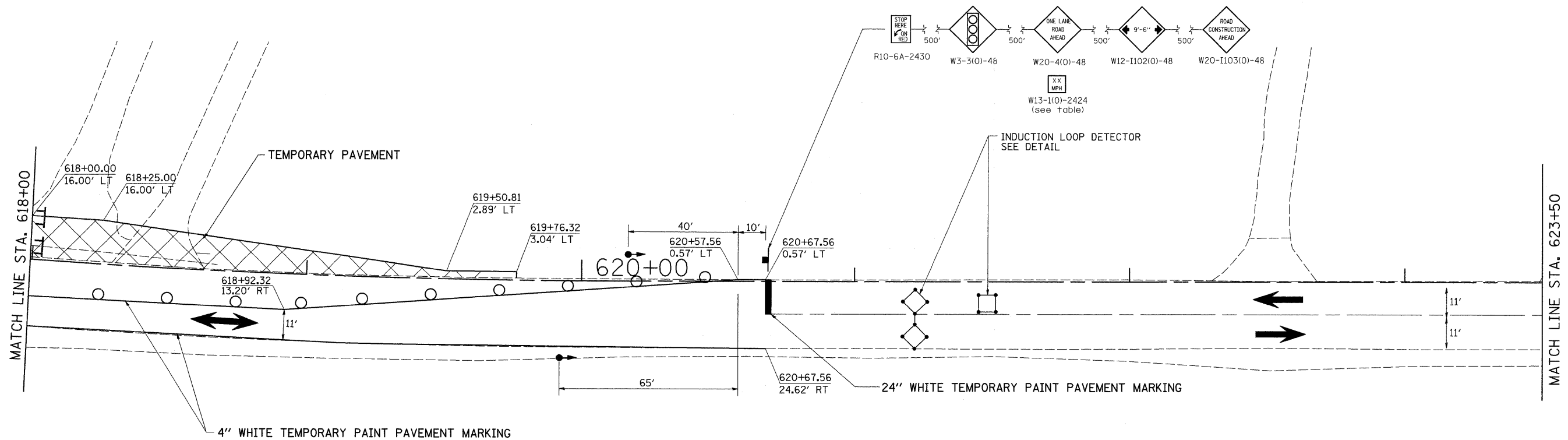

### STAGE 6 NOTES

1. USE STANDARD 701321. SEE STANDARDS FOR ADDITIONAL SIGNING AND DEVICES NOT SHOWN IN DETAILS.
2. REMOVAL OF EXISTING PAVEMENT FROM STA. 611+00 TO 618+00.
3. PLACE TEMPORARY SHEET PILING.
4. REMOVAL OF UPSTREAM PORTION OF EXISTING 4' X 4' BOX CULVERT. (MAINTAIN EXISTING FLOW.)
5. CONSTRUCT UPSTREAM END OF PRECAST DOUBLE 6' X 3' BOX CULVERT AT STA. 615+22.
6. CONSTRUCT SUB-BASE GRANULAR MATERIAL TYPE A.
7. CONSTRUCT COMBINATION CONCRETE CURB & GUTTER AND CLASS SI CONCRETE (OUTLET).
8. CONSTRUCT PCC PAVEMENT (JOINTED) & PCC SHOULDERS.
9. USE STANDARD 701326 TO CONSTRUCT TEMPORARY PAVEMENT FROM STA. 618+00 TO 619+77 LT.

	= WORK AREA
	= TYPE III BARRICADE WITH FLASHING LIGHTS
	= SIGN
	= BARRICADE, OR DRUM WITH STEADY BURNING LIGHTS
	= INDUCTION LOOP DETECTOR
	= TRAFFIC SIGNAL

FILE NAME =	USER NAME = cushmanbw	DESIGNED -	REVISED -	<b>STATE OF ILLINOIS DEPARTMENT OF TRANSPORTATION</b>	<b>STAGE 6</b>	F.A.P. RTE.	SECTION	COUNTY	TOTAL SHEETS	SHEET NO.	
cd\pw_work\PWIDOT\CUSHMANBW\dms34123\dms34123.dwg	6485atg69.dgn	DRAWN -	REVISED -			742	37RS-3	OGLE	345	83	
PLOT SCALE = 28.0000' / IN.	CHECKED -	REVISED -	REVISED -			CONTRACT NO. 84788					
PLOT DATE = Fri May 01 07:33:23 2009	DATE -	REVISED -	REVISED -			FED. ROAD DIST. NO. ILLINOIS FED. AID PROJECT					
SCALE: _____ SHEET NO. _____ OF _____ SHEETS _____ STA. _____ TO STA. _____											



# STAGE 7

## STA. 611 + 00 - 618 + 00

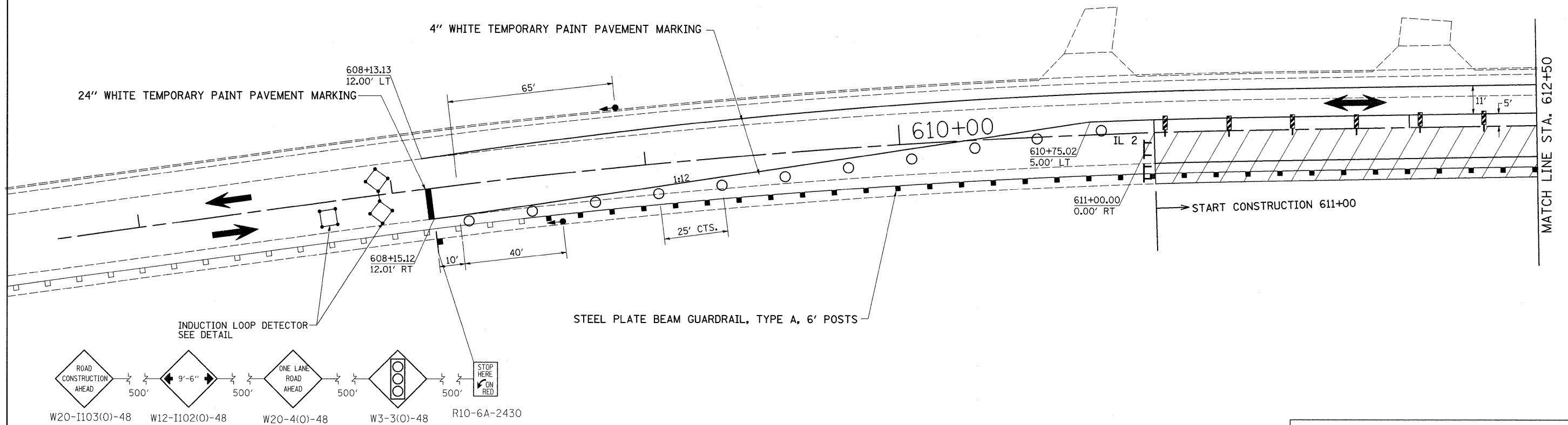

### STAGE 7 NOTES

1. USE STANDARD 701321. SEE STANDARDS FOR ADDITIONAL SIGNING AND DEVICES NOT SHOWN IN DETAILS.
2. REMOVAL OF REMAINING EXISTING PAVEMENT FROM STA. 611+00 TO 618+00.
3. REMOVAL OF DOWNSTREAM PORTION OF EXISTING 4' X 4' BOX CULVERT. (MAINTAIN EXISTING FLOW.)
4. CONSTRUCT DOWNSTREAM END OF PRECAST DOUBLE 6' X 3' BOX CULVERT AT STA. 615+22.
5. CONSTRUCT SUB-BASE GRANULAR MATERIAL TYPE A.
6. CONSTRUCT PCC PAVEMENT (JOINTED) & PCC SHOULDERS.
7. INSTALL STEEL PLATE BEAM GUARDRAIL, TYPE A, 6' POSTS FROM STA. 608+50 TO 615+50.
8. RELOCATE TEMPORARY IMPACT ATTENUATOR FROM STA. 608+50 TO 615+50.
9. USE STANDARD 701326 TO CONSTRUCT TEMPORARY PAVEMENT FROM STA. 617+12 TO 618+00 RT.

	= WORK AREA
	= TYPE III BARRICADE WITH FLASHING LIGHTS
	= SIGN
	= VERTICAL PANEL OR VERTICAL BARRICADE
	= BARRICADE, OR DRUM WITH STEADY BURNING LIGHTS
	= INDUCTION LOOP DETECTOR
	= TRAFFIC SIGNAL

FILE NAME =	USER NAME = cushmanbw	DESIGNED -	REVISED -	<b>STATE OF ILLINOIS DEPARTMENT OF TRANSPORTATION</b>	<b>STAGE 7</b>	F.A.P. RTE.	SECTION	COUNTY	TOTAL SHEETS	SHEET NO.	
ct\pw_work\VPWIDOT\CUSHMANBW\dms34123\066486stg69.dgn		DRAWN -	REVISED -			742	37RS-3	OGLE	345	84	
PLOT SCALE = 20.0000' / IN.		CHECKED -	REVISED -			CONTRACT NO. 84788					
PLOT DATE = Fri May 01 07:33:53 2009		DATE -	REVISED -			FED. ROAD DIST. NO. ILLINOIS FED. AID PROJECT					

# STAGE 7

## STA. 611 + 00 - 618 + 00

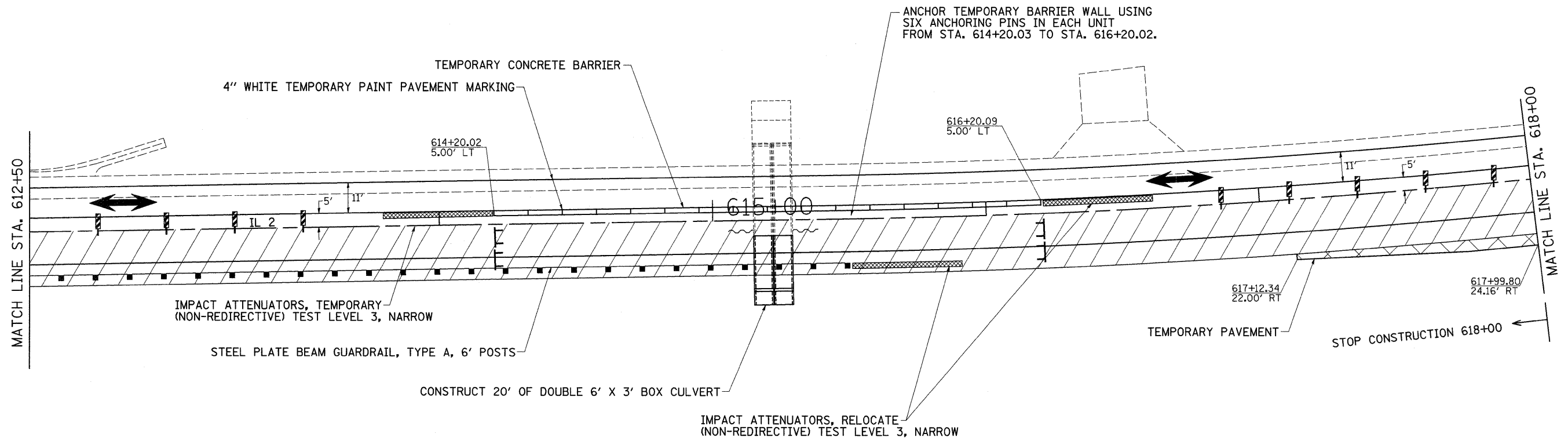

### STAGE 7 NOTES

1. USE STANDARD 701321. SEE STANDARDS FOR ADDITIONAL SIGNING AND DEVICES NOT SHOWN IN DETAILS.
2. REMOVAL OF REMAINING EXISTING PAVEMENT FROM STA. 611+00 TO 618+00.
3. REMOVAL OF DOWNSTREAM PORTION OF EXISTING 4' X 4' BOX CULVERT. (MAINTAIN EXISTING FLOW.)
4. CONSTRUCT DOWNSTREAM END OF PRECAST DOUBLE 6' X 3' BOX CULVERT AT STA. 615+22.
5. CONSTRUCT SUB-BASE GRANULAR MATERIAL TYPE A.
6. CONSTRUCT PCC PAVEMENT (JOINTED) & PCC SHOULDERS.
7. INSTALL STEEL PLATE BEAM GUARDRAIL, TYPE A, 6' POSTS FROM STA. 608+50 TO 615+50.
8. RELOCATE TEMPORARY IMPACT ATTENUATOR FROM STA. 608+50 TO 615+50.
9. USE STANDARD 701326 TO CONSTRUCT TEMPORARY PAVEMENT FROM STA. 617+12 TO 618+00 RT.

	= TEMPORARY SHEET PILING
	= WORK AREA
	= TYPE III BARRICADE WITH FLASHING LIGHTS
	= SIGN
	= VERTICAL PANEL OR VERTICAL BARRICADE
	= BARRICADE, OR DRUM WITH STEADY BURNING LIGHTS
	= INDUCTION LOOP DETECTOR
	= TRAFFIC SIGNAL

FILE NAME =	USER NAME = cushmanbw	DESIGNED -	REVISED -	<b>STATE OF ILLINOIS DEPARTMENT OF TRANSPORTATION</b>	<b>STAGE 7</b>	F.A.P. RTE.:	SECTION	COUNTY	TOTAL SHEETS	SHEET NO.	
ct\pw_work\PWIDOT\CUSHMANBW\dms34123\06486stg69.dgn	6486stg69.dgn	DRAWN -	REVISED -			742	37RS-3	OGLE	345	85	
PLOT SCALE = 20.0000' / IN.	CHECKED -	REVISED -				CONTRACT NO. 84788					
PLOT DATE = Fri May 01 07:34:07 2009	DATE -	REVISED -				FED. ROAD DIST. NO. ILLINOIS FED. AID PROJECT					
SCALE: _____ SHEET NO. _____ OF _____ SHEETS _____ STA. _____ TO STA. _____											

# STAGE 7

## STA. 611 + 00 - 618 + 00

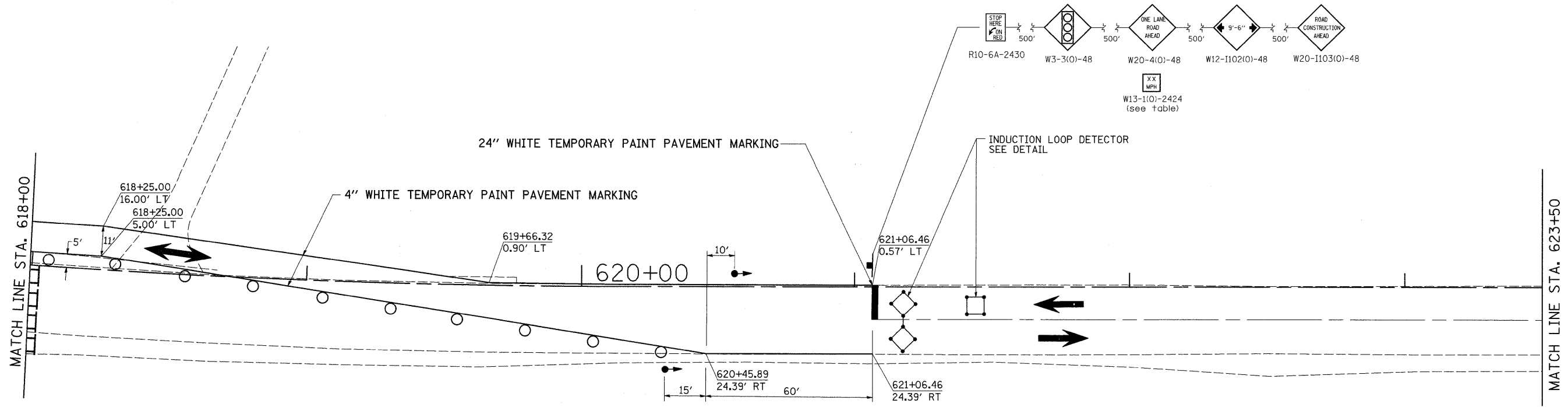

### STAGE 7 NOTES

1. USE STANDARD 701321. SEE STANDARDS FOR ADDITIONAL SIGNING AND DEVICES NOT SHOWN IN DETAILS.
2. REMOVAL OF REMAINING EXISTING PAVEMENT FROM STA. 611+00 TO 618+00.
3. REMOVAL OF DOWNSTREAM PORTION OF EXISTING 4' X 4' BOX CULVERT. (MAINTAIN EXISTING FLOW.)
4. CONSTRUCT DOWNSTREAM END OF PRECAST DOUBLE 6' X 3' BOX CULVERT AT STA. 615+22.
5. CONSTRUCT SUB-BASE GRANULAR MATERIAL TYPE A.
6. CONSTRUCT PCC PAVEMENT (JOINTED) & PCC SHOULDERS.
7. INSTALL STEEL PLATE BEAM GUARDRAIL, TYPE A, 6' POSTS FROM STA. 608+50 TO 615+50.
8. RELOCATE TEMPORARY IMPACT ATTENUATOR FROM STA. 608+50 TO 615+50.
9. USE STANDARD 701326 TO CONSTRUCT TEMPORARY PAVEMENT FROM STA. 617+12 TO 618+00 RT.

	= WORK AREA
	= TYPE III BARRICADE WITH FLASHING LIGHTS
	= SIGN
	= BARRICADE, OR DRUM WITH STEADY BURNING LIGHTS
	= INDUCTION LOOP DETECTOR
	= TRAFFIC SIGNAL

FILE NAME =	USER NAME = cushmanbw	DESIGNED -	REVISED -	<b>STATE OF ILLINOIS</b>	<b>STAGE 7</b>	F.A.P. RTE.	SECTION	COUNTY	TOTAL SHEETS	SHEET NO.
ca\pw_work\PWIDOT\CUSHMANBW\dms34123\066486stg69.dgn		DRAWN -	REVISED -	<b>DEPARTMENT OF TRANSPORTATION</b>		742	37RS-3	OGLE	345	86
	PLOT SCALE = 20.0000' / IN.	CHECKED -	REVISED -						CONTRACT NO. 84788	
	PLOT DATE = Fri May 01 07:34:18 2009	DATE -	REVISED -		SCALE:	SHEET NO.	OF	SHEETS	STA.	TO STA.
									FED. ROAD DIST. NO.	ILLINOIS FED. AID PROJECT

# STAGE 8

## STA. 618 + 00 - 628 + 29

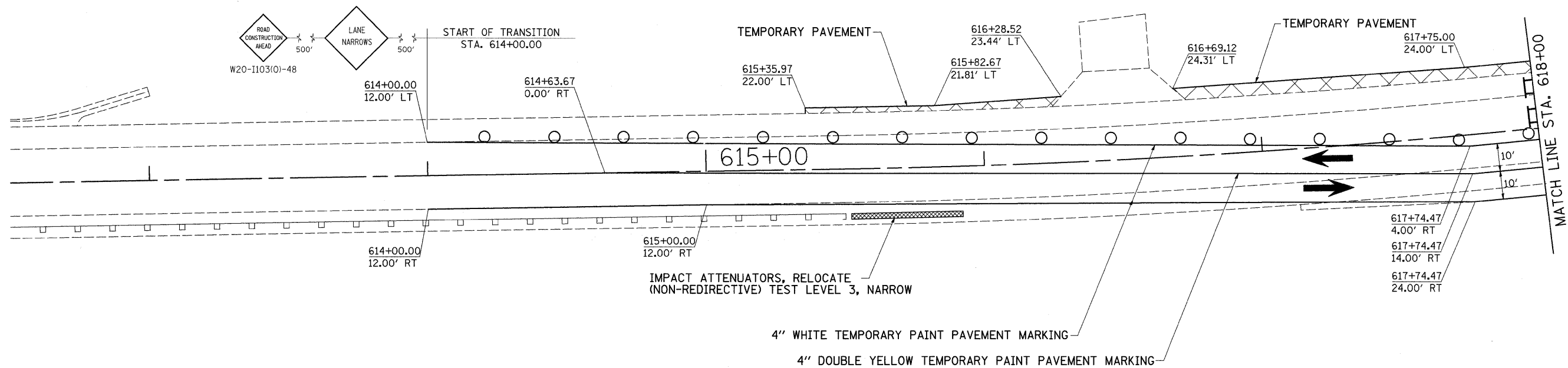

### STAGE 8 NOTES

1. USE STANDARD 701331. SEE STANDARDS FOR ADDITIONAL SIGNING AND DEVICES NOT SHOWN IN DETAILS.
3. CLOSE SIDEROAD "MARGARET FULLER RD." AS SHOWN.
4. REMOVAL OF EXISTING PAVEMENT FROM STA. 618+00 - 628+29.
5. REMOVAL OF EXISTING STRUCTURE AT STA. 618+62.
6. CONSTRUCT SUB-BASE GRANULAR MATERIAL, TYPE A.
7. CONSTRUCT PCC PAVEMENT (JOINTED) & PCC SHOULDERS.
8. USE STANDARD 701326 TO CONSTRUCT TEMPORARY PAVEMENT FROM STA. 615+35 TO 621+80 AND STA. 628+29 - 630+97 LT.

	= WORK AREA
	= TYPE III BARRICADE WITH FLASHING LIGHTS
	= SIGN
	= BARRICADE, OR DRUM WITH STEADY BURNING LIGHTS
	= INDUCTION LOOP DETECTOR
	= TRAFFIC SIGNAL

FILE NAME =	USER NAME = cushmanbw	DESIGNED -	REVISED -	<b>STATE OF ILLINOIS DEPARTMENT OF TRANSPORTATION</b>	<b>STAGE 8</b>	F.A.P. RTE. 742	SECTION 37RS-3	COUNTY OGLE	TOTAL SHEETS 345	SHEET NO. 87
cr\pw_work\PWIDOT\CUSHMANBW\dms34123\6486stg69.dgn		DRAWN -	REVISED -							
	PLOT SCALE = 20.0000' / IN.	CHECKED -	REVISED -							
	PLOT DATE = Fri May 01 07:34:48 2009	DATE -	REVISED -		SCALE:	SHEET NO.	OF	SHEETS	STA.	TO STA.
										FED. ROAD DIST. NO. ILLINOIS FED. AID PROJECT
										CONTRACT NO. 84788

# STAGE 8

STA. 618 + 00 - 628 + 29

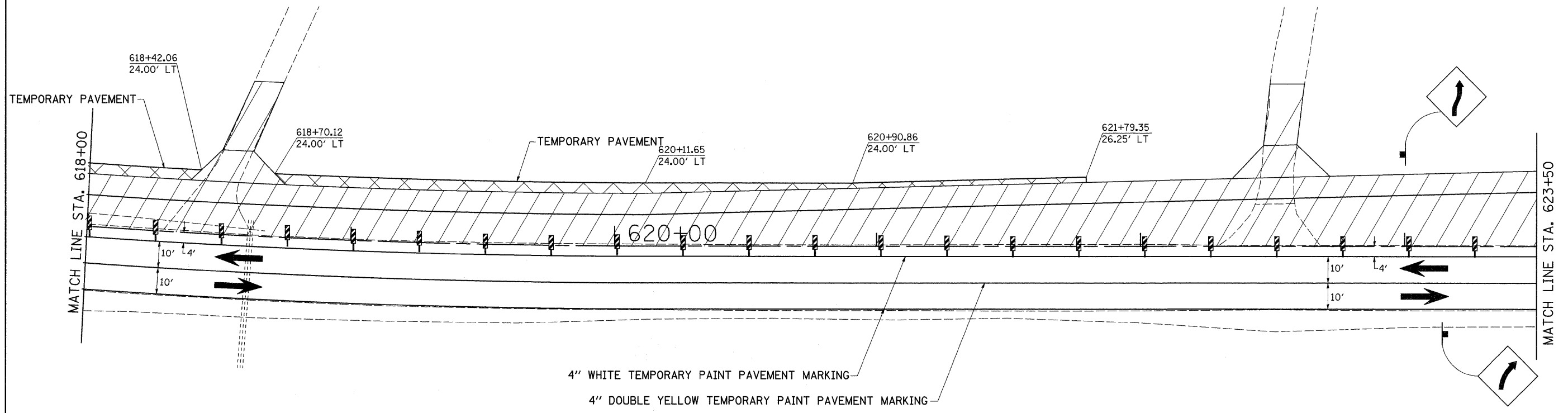

4" WHITE TEMPORARY PAINT PAVEMENT MARKING  
4" DOUBLE YELLOW TEMPORARY PAINT PAVEMENT MARKING

### STAGE 8 NOTES

1. USE STANDARD 701331. SEE STANDARDS FOR ADDITIONAL SIGNING AND DEVICES NOT SHOWN IN DETAILS.
3. CLOSE SIDEROAD "MARGARET FULLER RD." AS SHOWN.
4. REMOVAL OF EXISTING PAVEMENT FROM STA. 618+00 - 628+29.
5. REMOVAL OF EXISTING STRUCTURE AT STA. 618+62.
6. CONSTRUCT SUB-BASE GRANULAR MATERIAL, TYPE A.
7. CONSTRUCT PCC PAVEMENT (JOINTED) & PCC SHOULDERS.
8. USE STANDARD 701326 TO CONSTRUCT TEMPORARY PAVEMENT FROM STA. 615+35 TO 621+80 AND STA. 628+29 - 630+97 LT.

	= WORK AREA
	= TYPE III BARRICADE WITH FLASHING LIGHTS
	= SIGN
	= VERTICAL PANEL OR VERTICAL BARRICADE
	= BARRICADE, OR DRUM WITH STEADY BURNING LIGHTS
	= INDUCTION LOOP DETECTOR
	= TRAFFIC SIGNAL

FILE NAME =	USER NAME = cushmanbw	DESIGNED -	REVISED -	<b>STATE OF ILLINOIS DEPARTMENT OF TRANSPORTATION</b>	<b>STAGE 8</b>	F.A.P. RTE. 74?	SECTION 37RS-3	COUNTY OGLE	TOTAL SHEETS 345	SHEET NO. 88	
ct:\pw_work\PIWIDOT\CUSHMANBW\dms34123\dms6486stg69.dgn	PLOT SCALE = 20,0000' / IN.	DRAWN -	REVISED -			SCALE:	SHEET NO. OF SHEETS	STA. TO STA.	FED. ROAD DIST. NO.	ILLINOIS FED. AID PROJECT	CONTRACT NO. 84788
	PLOT DATE = Fri May 01 07:35:01 2009	CHECKED -	REVISED -								
		DATE -	REVISED -								

# STAGE 8

STA. 618 + 00 - 628 + 29

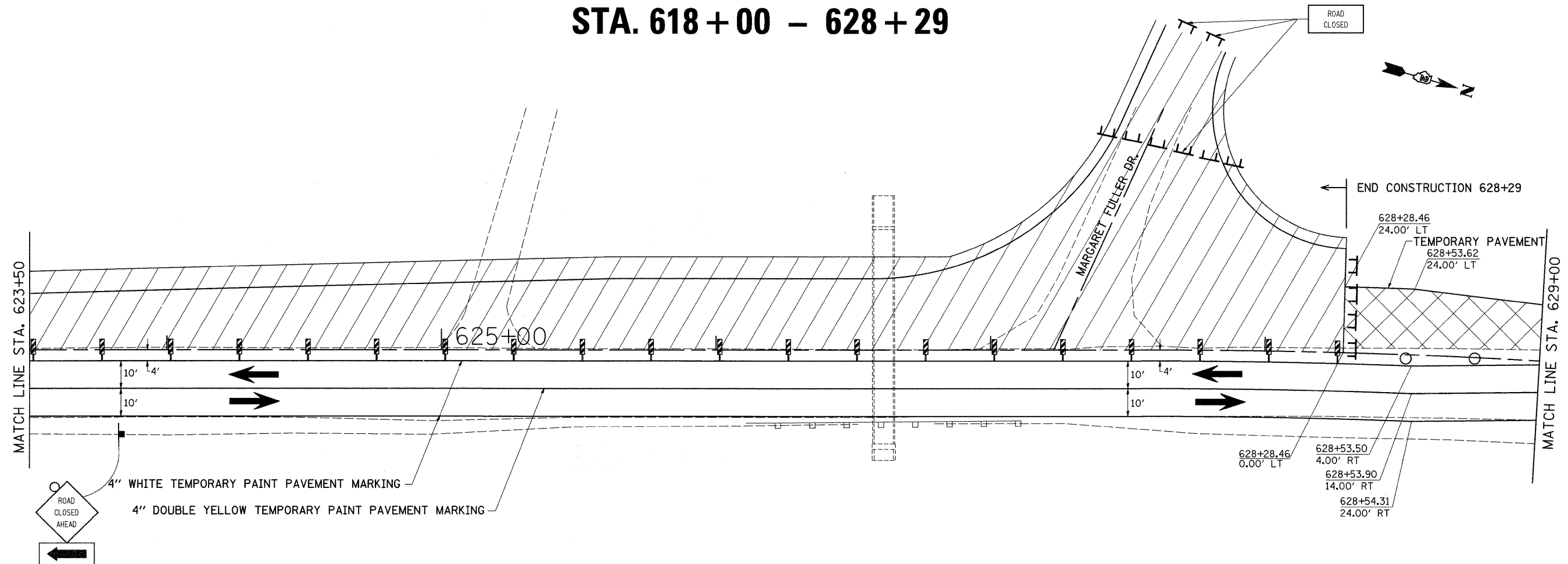

### STAGE 8 NOTES

1. USE STANDARD 701331. SEE STANDARDS FOR ADDITIONAL SIGNING AND DEVICES NOT SHOWN IN DETAILS.
3. CLOSE SIDEROAD "MARGARET FULLER RD." AS SHOWN.
4. REMOVAL OF EXISTING PAVEMENT FROM STA. 618+00 - 628+29.
5. REMOVAL OF EXISTING STRUCTURE AT STA. 618+62.
6. CONSTRUCT SUB-BASE GRANULAR MATERIAL, TYPE A.
7. CONSTRUCT PCC PAVEMENT (JOINTED) & PCC SHOULDERS.
8. USE STANDARD 701326 TO CONSTRUCT TEMPORARY PAVEMENT FROM STA. 615+35 TO 621+80 AND STA. 628+29 - 630+97 LT.

	= WORK AREA
	= TYPE III BARRICADE WITH FLASHING LIGHTS
	= SIGN
	= VERTICAL PANEL OR VERTICAL BARRICADE
	= BARRICADE, OR DRUM WITH STEADY BURNING LIGHTS
	= INDUCTION LOOP DETECTOR
	= TRAFFIC SIGNAL

FILE NAME =	USER NAME = cushmanbw	DESIGNED -	REVISED -	<b>STATE OF ILLINOIS DEPARTMENT OF TRANSPORTATION</b>	<b>STAGE 8</b>	F.A.P. RTE.	SECTION	COUNTY	TOTAL SHEETS	SHEET NO.
cs:\pw_work\PWIDOT\CUSHMANBW\dms34123\6486stg69.dgn	6486stg69.dgn	DRAWN -	REVISED -			742	37RS-3	OGLE	345	89
	PLOT SCALE = 20.0000' / IN.	CHECKED -	REVISED -			CONTRACT NO. 84788				
	PLOT DATE = Fri May 01 07:35:13 2009	DATE -	REVISED -			SCALE:	SHEET NO. OF SHEETS	STA. TO STA.	FED. ROAD DIST. NO.	ILLINOIS FED. AID PROJECT

# STAGE 8

STA. 618 + 00 - 628 + 29

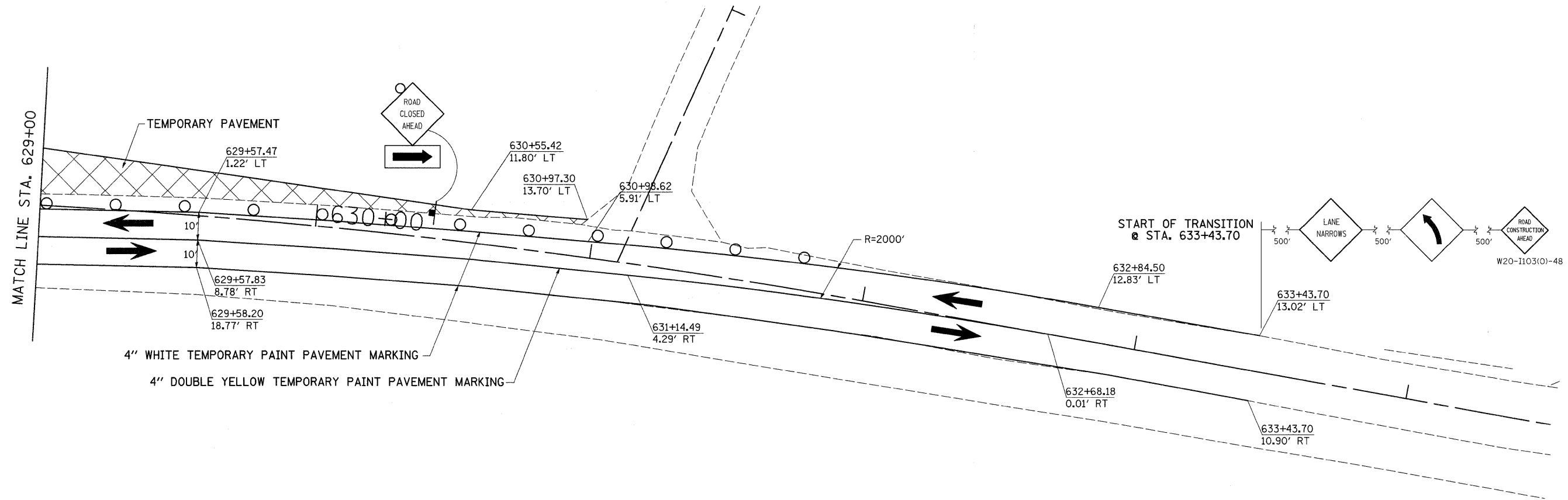

### STAGE 8 NOTES

1. USE STANDARD 701331. SEE STANDARDS FOR ADDITIONAL SIGNING AND DEVICES NOT SHOWN IN DETAILS.
3. CLOSE SIDEROAD "MARGARET FULLER RD." AS SHOWN.
4. REMOVAL OF EXISTING PAVEMENT FROM STA. 618+00 - 628+29.
5. REMOVAL OF EXISTING STRUCTURE AT STA. 618+62.
6. CONSTRUCT SUB-BASE GRANULAR MATERIAL, TYPE A.
7. CONSTRUCT PCC PAVEMENT (JOINTED) & PCC SHOULDERS.
8. USE STANDARD 701326 TO CONSTRUCT TEMPORARY PAVEMENT FROM STA. 615+35 TO 621+80 AND STA. 628+29 - 630+97 LT.

	= WORK AREA
	= TYPE III BARRICADE WITH FLASHING LIGHTS
	= SIGN
	= BARRICADE, OR DRUM WITH STEADY BURNING LIGHTS
	= INDUCTION LOOP DETECTOR
	= TRAFFIC SIGNAL

FILE NAME =	USER NAME = cushmanbw	DESIGNED -	REVISED -	<b>STATE OF ILLINOIS DEPARTMENT OF TRANSPORTATION</b>	<b>STAGE 8</b>	F.A.P. RTE.	SECTION	COUNTY	TOTAL SHEETS	SHEET NO.
es:\pw_work\PWIDOT\CUSHMANBW\dms34123\6486stg69.dgn	DRAWN -	REVISED -	742			37RS-3	OGLE	345	90	
PLOT SCALE = 20,0000' / IN.	CHECKED -	REVISED -	CONTRACT NO. 84788							
PLOT DATE = Fri May 01 07:35:27 2009	DATE -	REVISED -	FED. ROAD DIST. NO. [ILLINOIS] FED. AID PROJECT							
SCALE:		SHEET NO. OF SHEETS		STA. TO STA.						

# STAGE 9

STA. 618 + 00 - 628 + 29

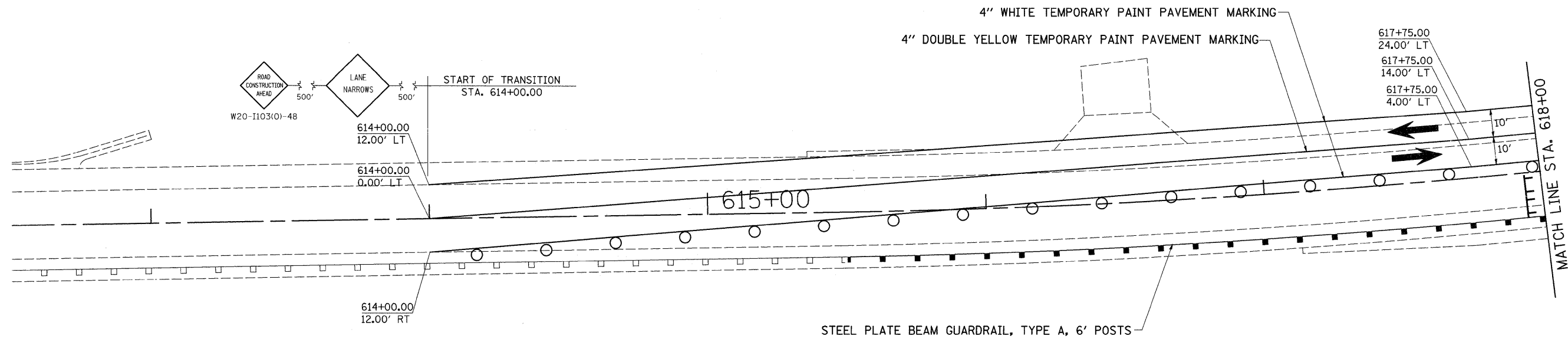

### STAGE 9 NOTES

1. USE STANDARD 701331. SEE STANDARDS FOR ADDITIONAL SIGNING AND DEVICES NOT SHOWN IN DETAILS.
2. REMOVE AND SALVAGE TRAFFIC BARRIER TERMINALS FROM STA. 626+11 TO 627+11.
3. REMOVAL OF REMAINING EXISTING PAVEMENT FROM STA. 618+00 TO 628+29.
4. CONSTRUCT SUB-BASE GRANULAR MATERIAL TYPE A.
5. CONSTRUCT PCC SHOULDERS (JOINTED) & PCC SHOULDERS.
6. INSTALL STEEL PLATE BEAM GUARDRAIL, TYPE A, 6' POSTS FROM STA. 615+50 TO 627+00.
7. RELOCATE TEMPORARY IMPACT ATTENUATOR FROM STA. 615+50 TO 627+00.

	= WORK AREA
	= TYPE III BARRICADE WITH FLASHING LIGHTS
	= SIGN
	= BARRICADE, OR DRUM WITH STEADY BURNING LIGHTS
	= INDUCTION LOOP DETECTOR
	= TRAFFIC SIGNAL

FILE NAME =	USER NAME = cushmonbw	DESIGNED -	REVISED -	<b>STATE OF ILLINOIS DEPARTMENT OF TRANSPORTATION</b>	<b>STAGE 9</b>	F.A.P. RTE.	SECTION	COUNTY	TOTAL SHEETS	SHEET NO.	
es:\pw_work\PWIDOT\CUSHMANBW\dms34123\6486stg69.dgn	6486stg69.dgn	DRAWN -	REVISED -			742	37RS-3	OGLE	345	91	
PLOT SCALE = 20.0000' / IN.		CHECKED -	REVISED -			CONTRACT NO. 84788					
PLOT DATE = Fri May 01 07:35:41 2009		DATE -	REVISED -			SCALE:	SHEET NO.	OF	SHEETS	STA.	TO STA.



# STAGE 9

STA. 618 + 00 - 628 + 29

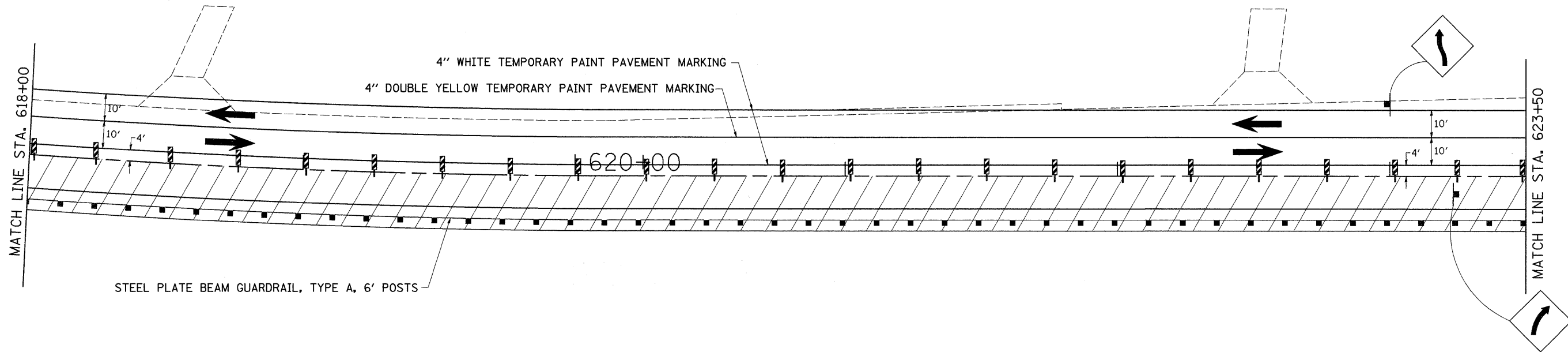

## STAGE 9 NOTES

1. USE STANDARD 701331. SEE STANDARDS FOR ADDITIONAL SIGNING AND DEVICES NOT SHOWN IN DETAILS.
2. REMOVE AND SALVAGE TRAFFIC BARRIER TERMINALS FROM STA. 626+11 TO 627+11.
3. REMOVAL OF REMAINING EXISTING PAVEMENT FROM STA. 618+00 TO 628+29.
4. CONSTRUCT SUB-BASE GRANULAR MATERIAL TYPE A.
5. CONSTRUCT PCC SHOULDERS (JOINTED) & PCC SHOULDERS.
6. INSTALL STEEL PLATE BEAM GUARDRAIL, TYPE A, 6' POSTS FROM STA. 615+50 TO 627+00.
7. RELOCATE TEMPORARY IMPACT ATTENUATOR FROM STA. 615+50 TO 627+00.

	= WORK AREA
	= TYPE III BARRICADE WITH FLASHING LIGHTS
	= SIGN
	= VERTICAL PANEL OR VERTICAL BARRICADE
	= BARRICADE, OR DRUM WITH STEADY BURNING LIGHTS
	= INDUCTION LOOP DETECTOR
	= TRAFFIC SIGNAL

FILE NAME =	USER NAME = cushmanbw	DESIGNED -	REVISED -
ca:\pw_work\PWIDOT\CUSHMANBW\dms34123\6486atg69.dgn		DRAWN -	REVISED -
PLOT SCALE = 20,0000' / IN.		CHECKED -	REVISED -
PLOT DATE = Fri May 01 07:35:53 2009		DATE -	REVISED -

STATE OF ILLINOIS  
DEPARTMENT OF TRANSPORTATION

## STAGE 9

F.A.P. RTE. 742	SECTION 37RS-3	COUNTY OGLE	TOTAL SHEETS 345	SHEET NO. 92
SCALE: SHEET NO. OF SHEETS STA. TO STA.			CONTRACT NO. 84788	
FED. ROAD DIST. NO. ILLINOIS FED. AID PROJECT				

# STAGE 9

STA. 618 + 00 - 628 + 29

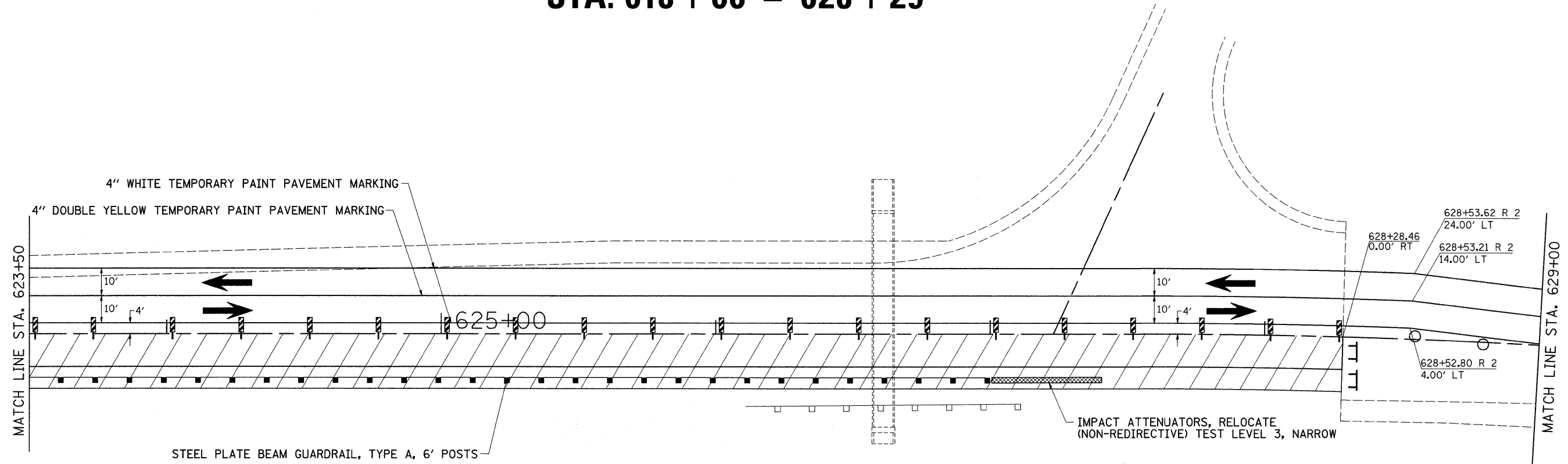

## STAGE 9 NOTES

1. USE STANDARD 701331. SEE STANDARDS FOR ADDITIONAL SIGNING AND DEVICES NOT SHOWN IN DETAILS.
2. REMOVE AND SALVAGE TRAFFIC BARRIER TERMINALS FROM STA. 626+11 TO 627+11.
3. REMOVAL OF REMAINING EXISTING PAVEMENT FROM STA. 618+00 TO 628+29.
4. CONSTRUCT SUB-BASE GRANULAR MATERIAL TYPE A.
5. CONSTRUCT PCC SHOULDERS (JOINTED) & PCC SHOULDERS.
6. INSTALL STEEL PLATE BEAM GUARDRAIL, TYPE A, 6' POSTS FROM STA. 615+50 TO 627+00.
7. RELOCATE TEMPORARY IMPACT ATTENUATOR FROM STA. 615+50 TO 627+00.

	= WORK AREA
	= TYPE III BARRICADE WITH FLASHING LIGHTS
	= SIGN
	= VERTICAL PANEL OR VERTICAL BARRICADE
	= BARRICADE, OR DRUM WITH STEADY BURNING LIGHTS
	= INDUCTION LOOP DETECTOR
	= TRAFFIC SIGNAL

FILE NAME =	USER NAME = oushmanbw	DESIGNED -	REVISED -	<b>STATE OF ILLINOIS DEPARTMENT OF TRANSPORTATION</b>	<b>STAGE 9</b>	F.A.P. RTE. 742	SECTION 37RS-3	COUNTY OGLE	TOTAL SHEETS 345	SHEET NO. 93
es:\pw_work\PIWIDOT\CUSHMANBW\dms34123\6486stg69.dgn	PLOT SCALE = 20,0000' / IN.	DRAWN -	REVISED -			CONTRACT NO. 84788				
	PLOT DATE = Fri May 01 07:36:05 2009	CHECKED -	REVISED -			SCALE:	SHEET NO. OF SHEETS STA. TO STA.	FED. ROAD DIST. NO. [ILLINOIS] FED. AID PROJECT		
		DATE -	REVISED -							

# STAGE 9

STA. 618 + 00 - 628 + 29

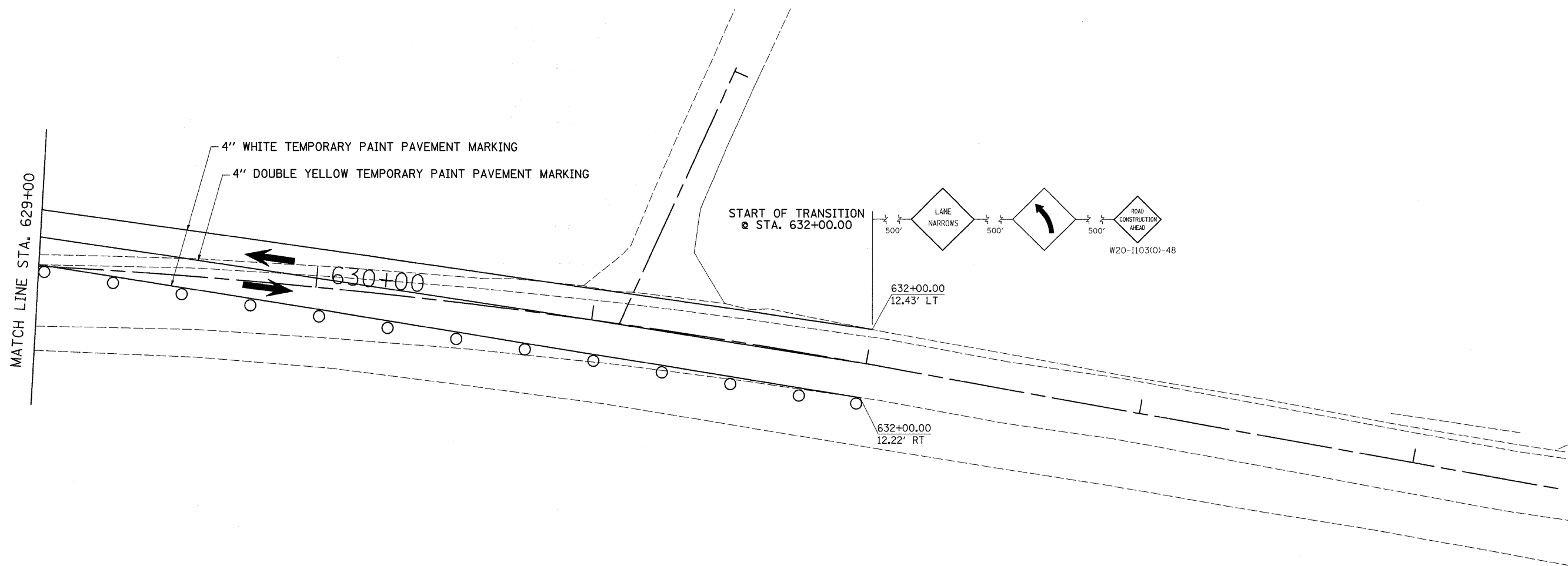

### STAGE 9 NOTES

1. USE STANDARD 701331. SEE STANDARDS FOR ADDITIONAL SIGNING AND DEVICES NOT SHOWN IN DETAILS.
2. REMOVE AND SALVAGE TRAFFIC BARRIER TERMINALS FROM STA. 626+11 TO 627+11.
3. REMOVAL OF REMAINING EXISTING PAVEMENT FROM STA. 618+00 TO 628+29.
4. CONSTRUCT SUB-BASE GRANULAR MATERIAL TYPE A.
5. CONSTRUCT PCC SHOULDERS (JOINTED) & PCC SHOULDERS.
6. INSTALL STEEL PLATE BEAM GUARDRAIL, TYPE A, 6' POSTS FROM STA. 615+50 TO 627+00.
7. RELOCATE TEMPORARY IMPACT ATTENUATOR FROM STA. 615+50 TO 627+00.

	= WORK AREA
	= TYPE III BARRICADE WITH FLASHING LIGHTS
	= SIGN
	= BARRICADE, OR DRUM WITH STEADY BURNING LIGHTS
	= INDUCTION LOOP DETECTOR
	= TRAFFIC SIGNAL

FILE NAME =	USER NAME = cushmanbw	DESIGNED -	REVISED -	<b>STATE OF ILLINOIS DEPARTMENT OF TRANSPORTATION</b>	<b>STAGE 9</b>	F.A.P. RTE.	SECTION	COUNTY	TOTAL SHEETS	SHEET NO.
es:\p\work\PWIDOT\CUSHMANBW\dms34123\466486\sg69.dgn	DRAWN -	REVISED -	742			37RS-3	OGLE	345	94	
PLOT SCALE = 20.0000' / IN.	CHECKED -	REVISED -	CONTRACT NO. 84788							
PLOT DATE = Fri May 01 07:36:16 2009	DATE -	REVISED -	FED. ROAD DIST. NO. ILLINOIS FED. AID PROJECT							
SCALE: SHEET NO. OF SHEETS STA. TO STA.										

# STAGE 10

STA. 628 + 29 - 673 + 00

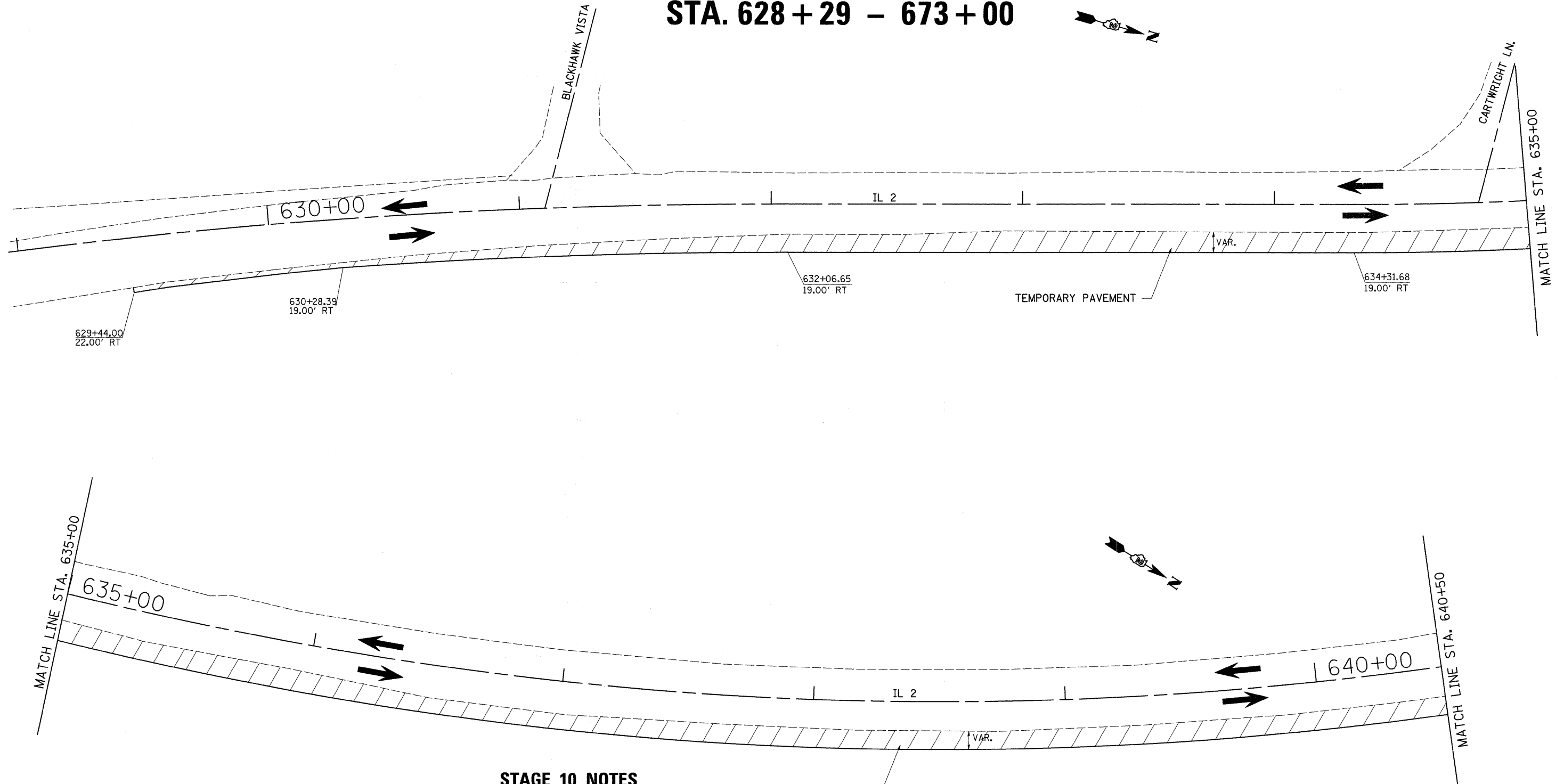

### STAGE 10 NOTES

1. USE STANDARD 701326. SEE STANDARDS FOR ADDITIONAL SIGNING AND DEVICES NOT SHOWN IN DETAILS.
2. CONSTRUCT TEMPORARY PAVEMENT FROM STA. 629+44 TO 669+50.

TEMPORARY PAVEMENT

	= WORK AREA
	= TYPE III BARRICADE WITH FLASHING LIGHTS
	= SIGN

FILE NAME =	USER NAME = cushmanbw	DESIGNED -	REVISED -
es:\pw_work\PWIDOT\CUSHMANBW\dms34123\06486atg69.dgn		DRAWN -	REVISED -
		CHECKED -	REVISED -
		DATE -	REVISED -

STATE OF ILLINOIS  
DEPARTMENT OF TRANSPORTATION

## STAGE 10

SCALE: SHEET NO. OF SHEETS STA. TO STA.

F.A.P. RTE.	SECTION	COUNTY	TOTAL SHEETS	SHEET NO.
742	37RS-3	OGLE	345	95
CONTRACT NO. 84788				
FED. ROAD DIST. NO. ILLINOIS FED. AID PROJECT				

# STAGE 10

STA. 628 + 29 - 673 + 00

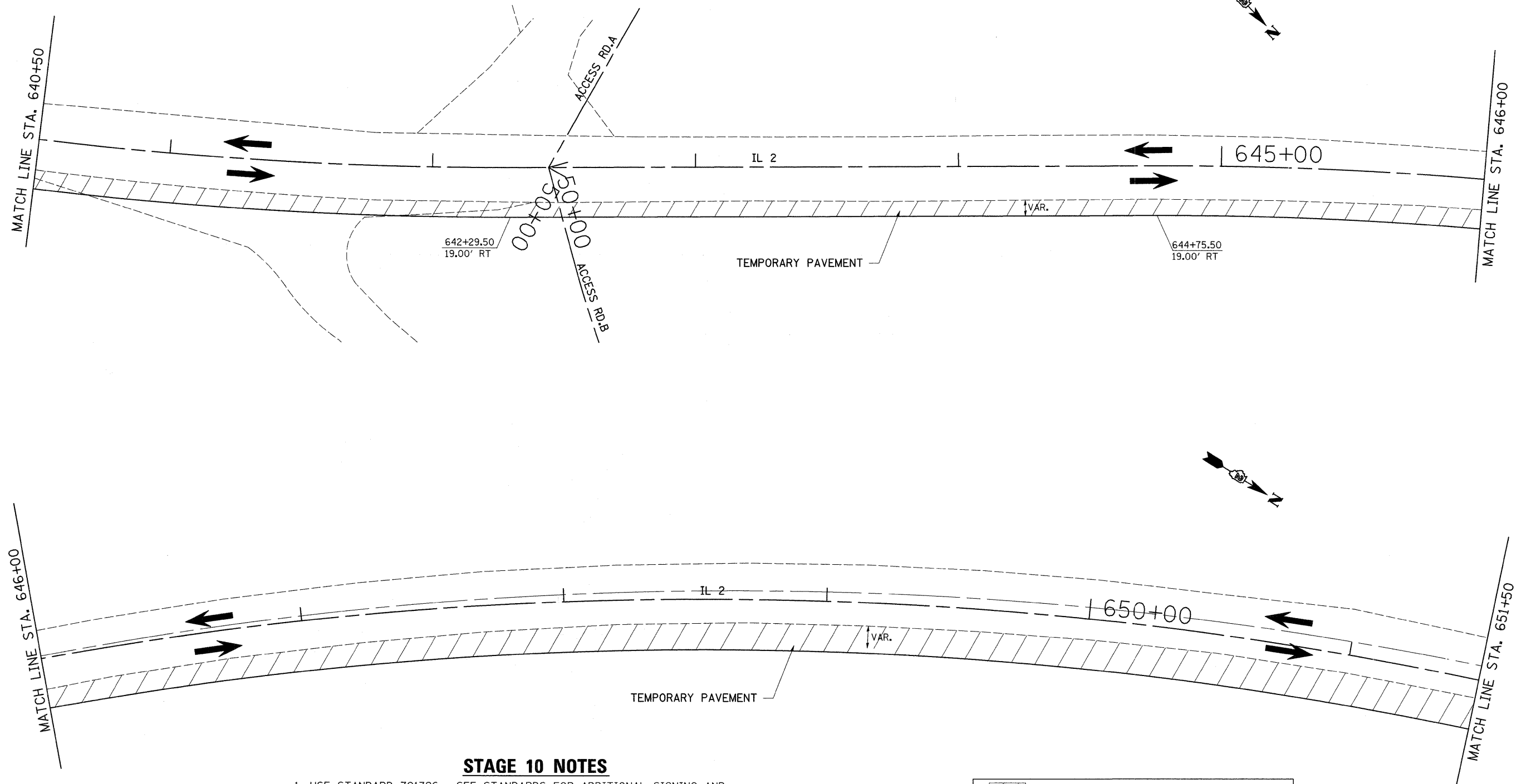

### STAGE 10 NOTES

1. USE STANDARD 701326. SEE STANDARDS FOR ADDITIONAL SIGNING AND DEVICES NOT SHOWN IN DETAILS.
2. CONSTRUCT TEMPORARY PAVEMENT FROM STA. 629+44 TO 669+50.

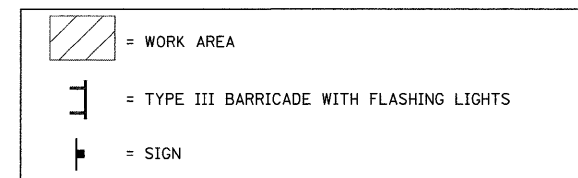

FILE NAME =	USER NAME = cushmanbw	DESIGNED -	REVISED -	<b>STATE OF ILLINOIS DEPARTMENT OF TRANSPORTATION</b>	<b>STAGE 10</b>		F.A.P. RTE.	SECTION	COUNTY	TOTAL SHEETS	SHEET NO.
ct:\pwork\pwidot\CUSHMANBW\dms34123\6486stg69.dgn		DRAWN -	REVISED -				742	37RS-3	OGLE	345	96
		CHECKED -	REVISED -		SCALE: SHEET NO. OF SHEETS STA. TO STA.		CONTRACT NO. 84788				
		DATE -	REVISED -		FED. ROAD DIST. NO. ILLINOIS FED. AID PROJECT						

# STAGE 10

## STA. 628 + 29 - 673 + 00

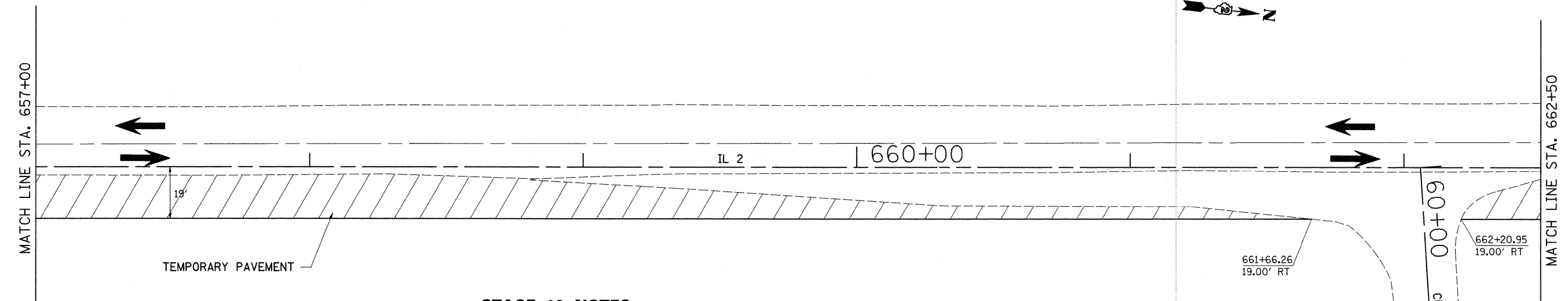
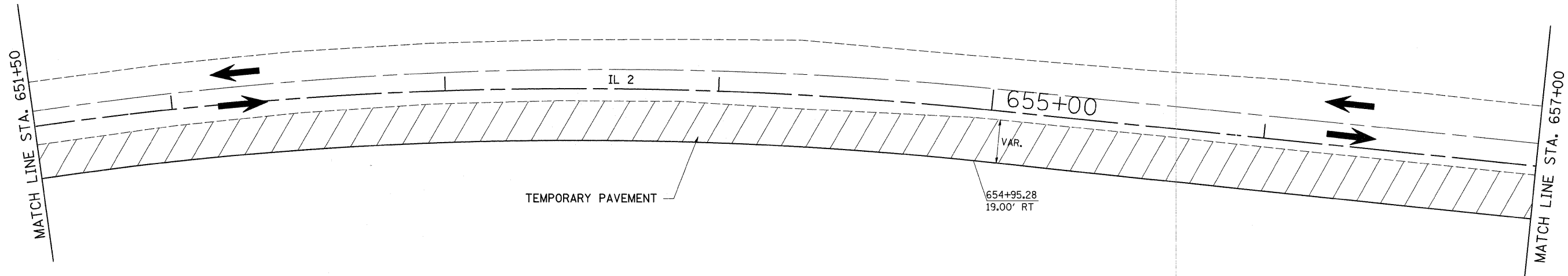

### STAGE 10 NOTES

1. USE STANDARD 701326. SEE STANDARDS FOR ADDITIONAL SIGNING AND DEVICES NOT SHOWN IN DETAILS.
2. CONSTRUCT TEMPORARY PAVEMENT FROM STA. 629+44 TO 669+50.

	= WORK AREA
	= TYPE III BARRICADE WITH FLASHING LIGHTS
	= SIGN

FILE NAME =	USER NAME = cushmanbw	DESIGNED -	REVISED -
ci\pwr_work\pwwid01\CUSHMANBW\dms34123\dms34123\6496stg69.dgn		DRAWN -	REVISED -
PLOT SCALE = 20,0000 / IN.		CHECKED -	REVISED -
PLOT DATE = Fri May 01 07:36:58 2009		DATE -	REVISED -

**STATE OF ILLINOIS  
DEPARTMENT OF TRANSPORTATION**

## STAGE 10

SCALE: SHEET NO. OF SHEETS STA. TO STA.

F.A.P. RTE. 742	SECTION 37RS-3	COUNTY OGLE	TOTAL SHEETS 345	SHEET NO. 97
CONTRACT NO. 84788				
FED. ROAD DIST. NO. [ILLINOIS] FED. AID PROJECT				

# STAGE 10

STA. 628 + 29 - 673 + 00

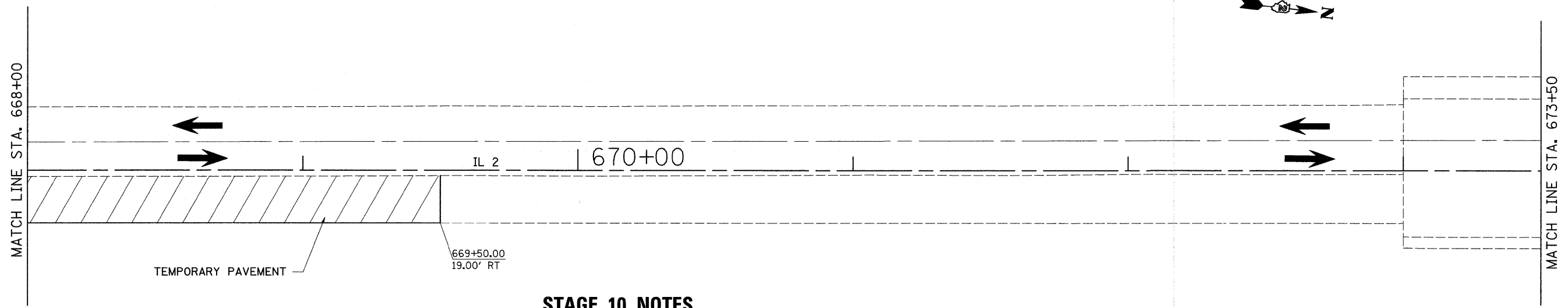
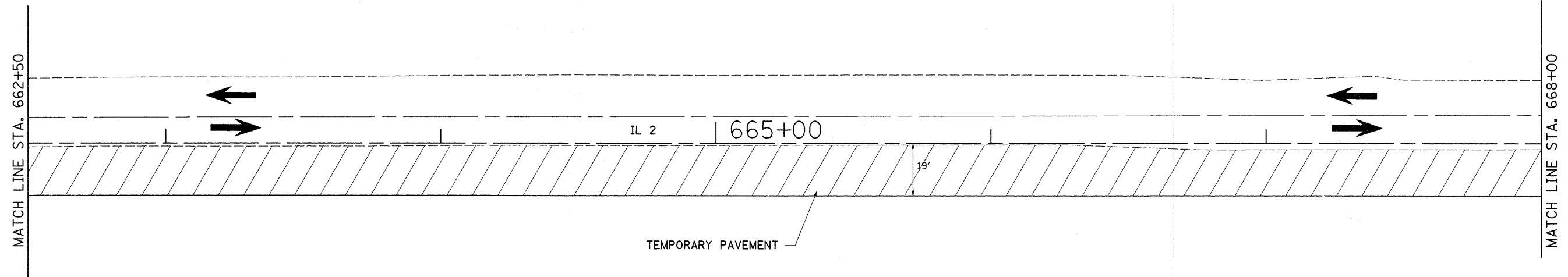

### STAGE 10 NOTES

1. USE STANDARD 701326. SEE STANDARDS FOR ADDITIONAL SIGNING AND DEVICES NOT SHOWN IN DETAILS.
2. CONSTRUCT TEMPORARY PAVEMENT FROM STA. 629+44 TO 669+50.

	= WORK AREA
	= TYPE III BARRICADE WITH FLASHING LIGHTS
	= SIGN

FILE NAME =	USER NAME = cushmanbw	DESIGNED -	REVISED -	<b>STATE OF ILLINOIS DEPARTMENT OF TRANSPORTATION</b>	<b>STAGE 10</b>				F.A.P. RTE.	SECTION	COUNTY	TOTAL SHEETS	SHEET NO.
ct:\pw_work\PW\IDOT\CUSHMANBW\dms34123\dms34123\6486stg69.dgn		DRAWN -	REVISED -		742	37RS-3	OGLE	345	98				
PLOT SCALE = 20.0000' / IN.		CHECKED -	REVISED -		SCALE: SHEET NO. OF SHEETS STA. TO STA.				FED. ROAD DIST. NO.	ILLINOIS FED. AID PROJECT	CONTRACT NO. 84788		
PLOT DATE = Fri May 01 07:37:09 2009		DATE -	REVISED -										

# STAGE 11

STA. 628 + 29 - 673 + 00

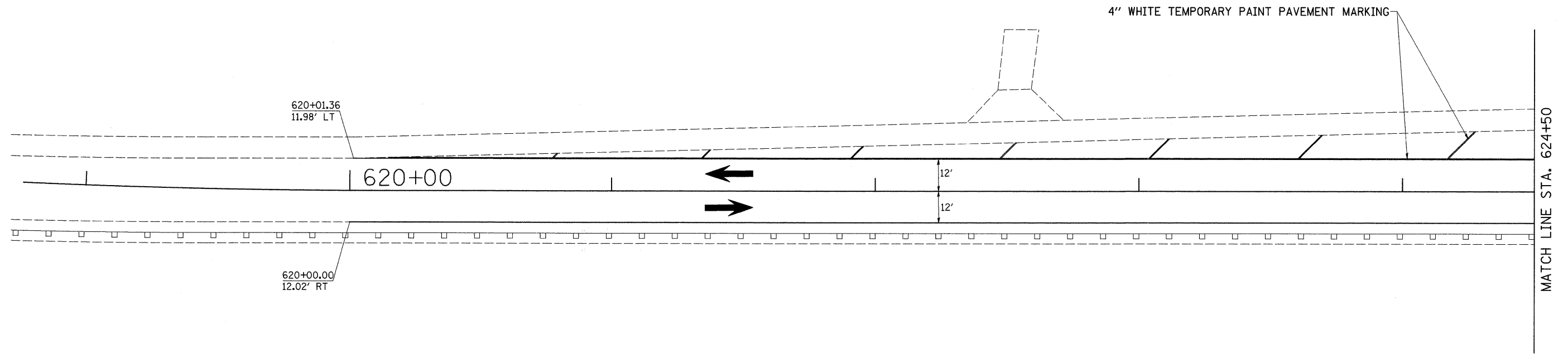

## STAGE 11 NOTES

1. USE STANDARD 701331. SEE STANDARDS FOR ADDITIONAL SIGNING AND DEVICES NOT SHOWN IN DETAILS.
2. CLOSE SIDEROADS "BLACKHAWK VISTA" AND "CARTWRIGHT LN." AS SHOWN
3. REMOVAL OF EXISTING PAVEMENT FROM STA. 628+29 TO 673+00 TO STAGE LINE.
4. CONSTRUCT SUB-BASE GRANULAR MATERIAL TYPE A.
5. CONSTRUCT STORM SEWER, INLETS AND COMBINATION CONCRETE CURB & GUTTER.
6. CONSTRUCT PCC PAVEMENT (JOINTED) & PCC SHOULDERS.

	= WORK AREA
	= TYPE III BARRICADE WITH FLASHING LIGHTS
	= SIGN
	= BARRICADE, OR DRUM WITH STEADY BURNING LIGHTS
	= VERTICAL PANEL OR VERTICAL BARRICADE

FILE NAME =	USER NAME = oushmanbw	DESIGNED -	REVISED -	<b>STATE OF ILLINOIS DEPARTMENT OF TRANSPORTATION</b>	<b>STAGE 11</b>	F.A.P. RTE.	SECTION	COUNTY	TOTAL SHEETS	SHEET NO.	
os\pwwork\PWIDOT\CUSHMANBW\dms34123\6486stg69.dgn		DRAWN -	REVISED -			742	37RS-3	OGLE	345	99	
		CHECKED -	REVISED -			SCALE: SHEET NO. OF SHEETS STA. TO STA.		CONTRACT NO. 84788			
		DATE -	REVISED -					FED. ROAD DIST. NO. ILLINOIS FED. AID PROJECT			



# STAGE 11

## STA. 628 + 29 - 673 + 00

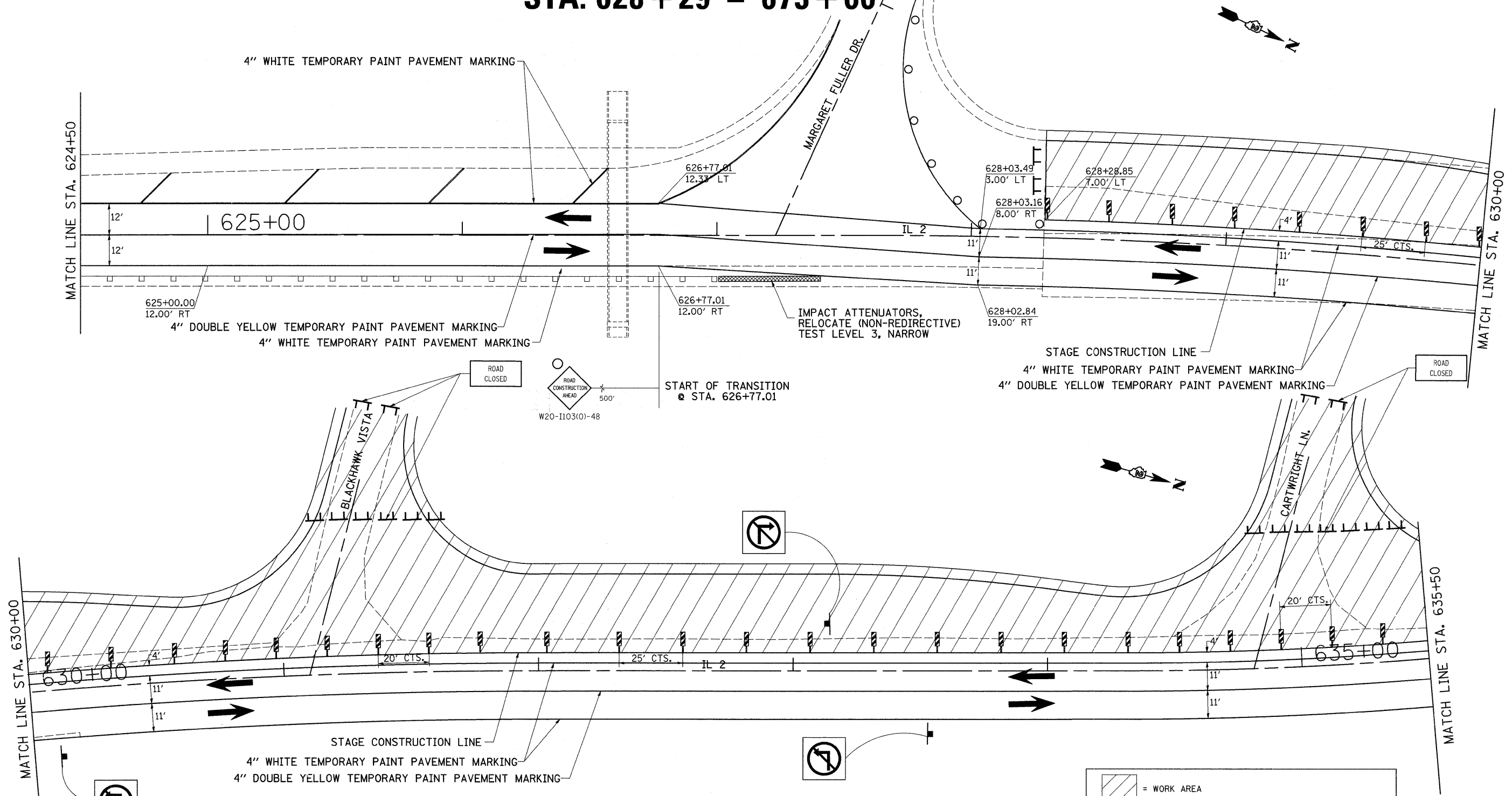

### STAGE 11 NOTES

1. USE STANDARD 701331. SEE STANDARDS FOR ADDITIONAL SIGNING AND DEVICES NOT SHOWN IN DETAILS.
2. CLOSE SIDEROADS "BLACKHAWK VISTA" AND "CARTWRIGHT LN." AS SHOWN
3. REMOVAL OF EXISTING PAVEMENT FROM STA. 628+29 TO 673+00 TO STAGE LINE.
4. CONSTRUCT SUB-BASE GRANULAR MATERIAL TYPE A.
5. CONSTRUCT STORM SEWER, INLETS AND COMBINATION CONCRETE CURB & GUTTER.
6. CONSTRUCT PCC PAVEMENT (JOINTED) & PCC SHOULDERS.

	= WORK AREA
	= TYPE III BARRICADE WITH FLASHING LIGHTS
	= SIGN
	= BARRICADE, OR DRUM WITH STEADY BURNING LIGHTS
	= VERTICAL PANEL OR VERTICAL BARRICADE

**STATE OF ILLINOIS**  
**DEPARTMENT OF TRANSPORTATION**

## STAGE 11

FILE NAME =	USER NAME = cushmanbw	DESIGNED -	REVISED -	<b>STATE OF ILLINOIS</b> <b>DEPARTMENT OF TRANSPORTATION</b>	<b>STAGE 11</b>	F.A.P. RTE.	SECTION	COUNTY	TOTAL SHEETS	SHEET NO.	
ct:\pw\work\VPWIDOT\CUSHMANBW\dms34123\dms34123.dgn	6486stg69.dgn	DRAWN -	REVISED -			742	37RS-3	OGLE	345	100	
PLOT SCALE = 20,0000' / IN.	CHECKED -	REVISED -	REVISED -			CONTRACT NO. 84788					
PLOT DATE = Fri May 01 07:37:32 2009	DATE -	REVISED -	REVISED -			SCALE: SHEET NO. OF SHEETS STA. TO STA.		FED. ROAD DIST. NO. ILLINOIS FED. AID PROJECT			