

SECTION C-C

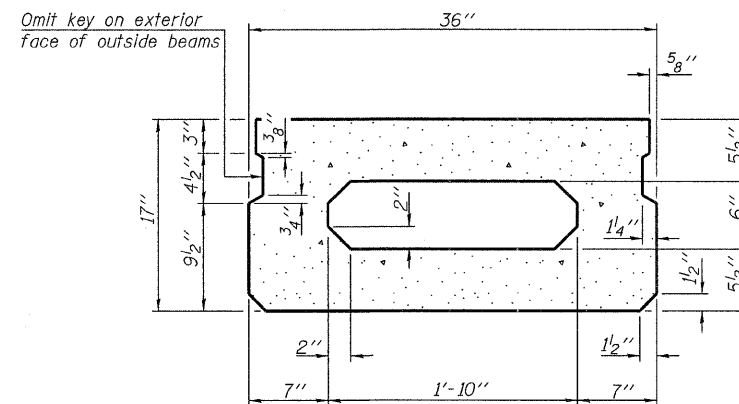

SECTION A-A
(Showing dimensions)

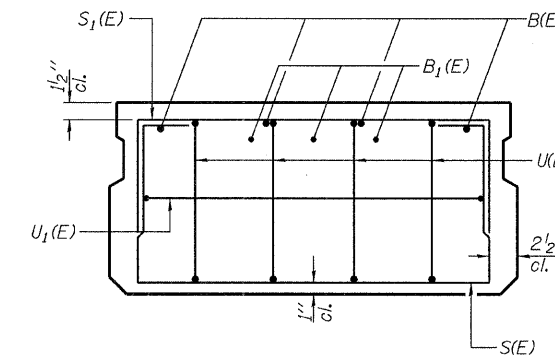

VIEW B-B

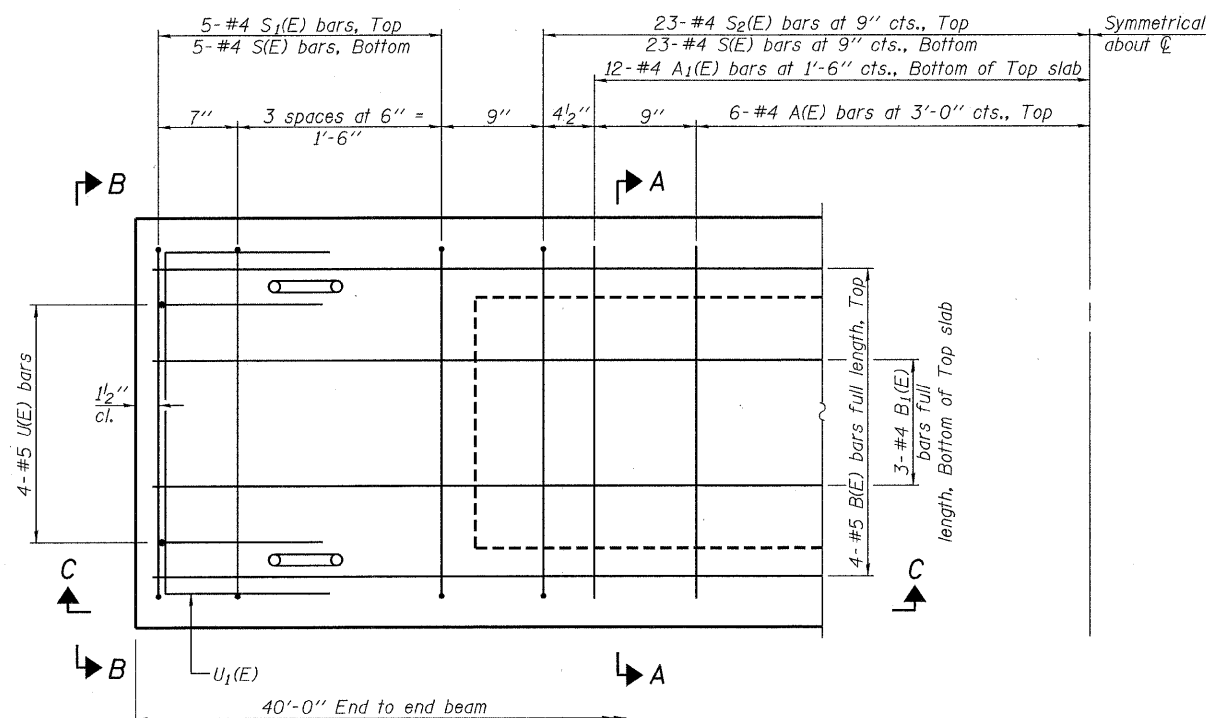

PLAN VIEW

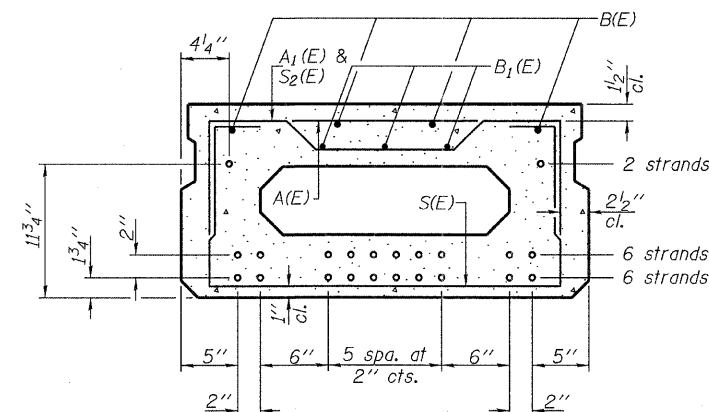

SECTION A-A
(Showing reinforcement and permissible strand locations)

Note: Place the number of strands specified in each row symmetrically about the centerline of beam in the permissible strand locations shown.

BAR LIST
ONE BEAM ONLY

(For information only)

Bar	No.	Size	Length	Shape
A(E)	12	#4	2'-7"	—
A1(E)	24	#4	2'-11"	—
B(E)	4	#5	39'-8"	—
B1(E)	3	#4	39'-8"	—
S(E)	56	#4	5'-9"	□
S1(E)	10	#4	4'-3"	□
S2(E)	46	#4	4'-6"	□
U(E)	8	#5	3'-8"	□
U1(E)	2	#4	5'-0"	□

Note: See sheet 15 & 16 for additional details and Bill of Material.

Note: Spacing of S(E) and S2(E) bars may be adjusted up to 4" in the immediate area of the transverse tie diaphragms to miss the block outs for the transverse ties.

DESIGNED - A.S.L.
CHECKED - M.G.B.
DRAWN - D.T.M.
CHECKED - D.A.B.

PD-1736-0 5-16-08

HAMPTON, LENZINI & RENWICK, INC.
CIVIL & STRUCTURAL ENGINEERS
LAND SURVEYORS

HLR 3085 STEVENSON DRIVE, SUITE 201
SPRINGFIELD, ILLINOIS 62703
(217) 546-3400

PROJECT NUMBER: 07.0432.130 DATE: 03/31/09

F.A.S.	SECTION	COUNTY	TOTAL SHEETS	SHEET NO.
340	09-00106-00-BR	FORD	32	15
CONTRACT NO. 87411				
FED. ROAD DIST. NO. ILLINOIS FED. AID PROJECT				

SUPERSTRUCTURE
17" X 36" PPC DECK BEAM
STRUCTURE NO. 027-3438