

**METAL SHELL PILE TABLE**

Designation and outside diameter	Wall thickness t	Weight per foot (Lbs./ft.)	Inside volume (yd. <sup>3</sup> /ft.)
PP12	0.179"	22.60	0.0274
PP12	0.250"	31.37	0.0267
PP14	0.250"	36.71	0.0368
PP14	0.312"	45.61	0.0361

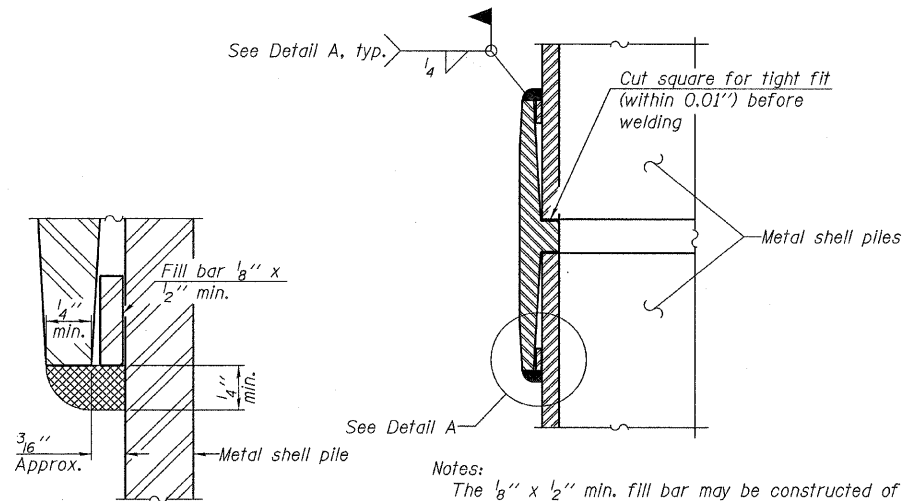

**DETAIL A**

Notes:  
 The 1/8" x 1/2" min. fill bar may be constructed of 2 bars with a 1/8" max. gap between them.  
 Pile segments shall be driven to solid contact with splicer before welding.

**WELDED COMMERCIAL SPLICE**

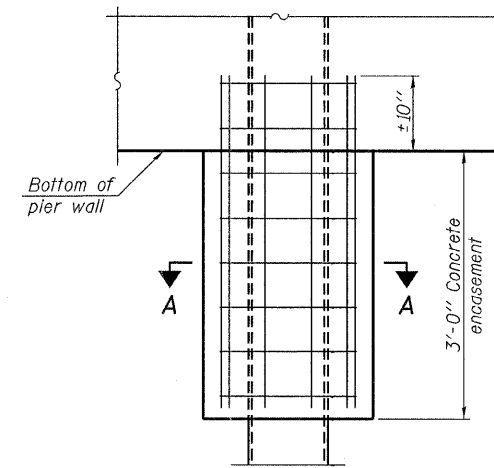

**ELEVATION**

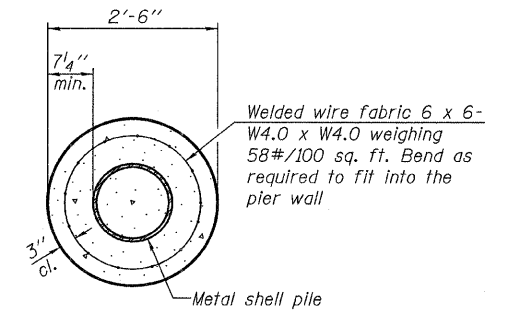

**SECTION A-A**

Note: Forms for encasement may be omitted when soil conditions permit.

**CONCRETE ENCASEMENT AT PIERS**

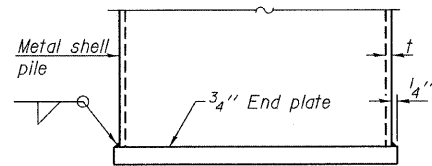

**END PLATE ATTACHMENT**

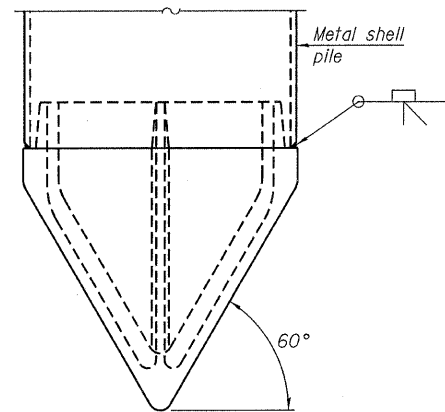

**METAL SHELL PILE SHOE ATTACHMENT**

(See Note A)

Note A:  
 When called for on the plans, the Contractor shall furnish metal shell pile shoes consisting of a single piece conical pile point as shown. The pile shoes shall be cast in one piece steel according to either ASTM A 148 Grade 90-60 or AASHTO M 103 Grade 65-35 and shall provide full bearing over the full circumference of the metal shell pile. The pile shoe shall have tapered leads to assure proper alignment and fitting and shall be secured to the pile with a circumferential weld.

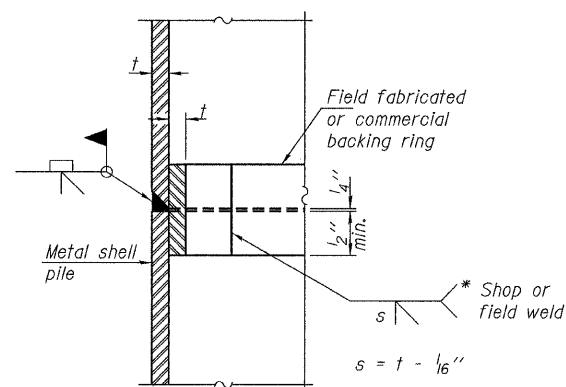

**COMPLETE PENETRATION WELD SPLICE**

\* Field fabricated backing ring may be made from pile shell by removing segment to allow reducing circumference and vertically rejoin with partial joint penetration weld.

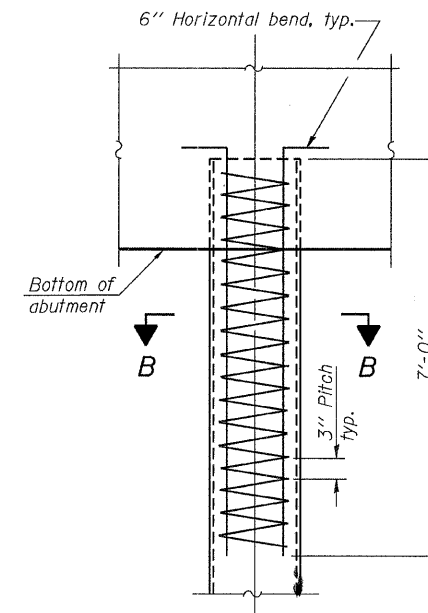

**ELEVATION**

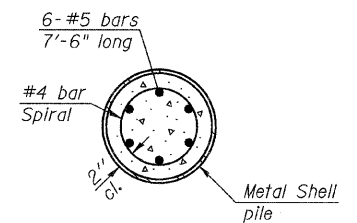

**SECTION B-B**

**METAL SHELL REINFORCEMENT AT ABUTMENTS**

Note: The metal shell piles shall be according to ASTM A 252 Grade 3.

**METAL SHELL PILE DETAILS  
 STRUCTURE NO. 027-3438**

DESIGNED - A.S.L.
CHECKED - M.G.B.
DRAWN - D.T.M.
CHECKED - D.A.B.

F-MS

5-16-08

**HAMPTON, LENZINI & RENWICK, INC.**  
 CIVIL & STRUCTURAL ENGINEERS  
 LAND SURVEYORS

**HLR** 3085 STEVENSON DRIVE, SUITE 201  
 SPRINGFIELD, ILLINOIS 62703  
 (217) 546-3400

PROJECT NUMBER: 07.0432.130 DATE: 03/31/09

F.A.S.	SECTION	COUNTY	TOTAL SHEETS	SHEET NO.
340	09-00106-00-BR	FORD	32	20
CONTRACT NO. 87411				
FED. ROAD DIST. NO.		ILLINOIS FED. AID PROJECT		