

F.A.P. RTE.	SECTION	COUNTY	WILL.	TOTAL SHEETS	SHEET NO.
353	12R-4			199	122
STA.	TO STA.				
FED. ROAD DIST. NO.	ILLINOIS FED. AID PROJECT				

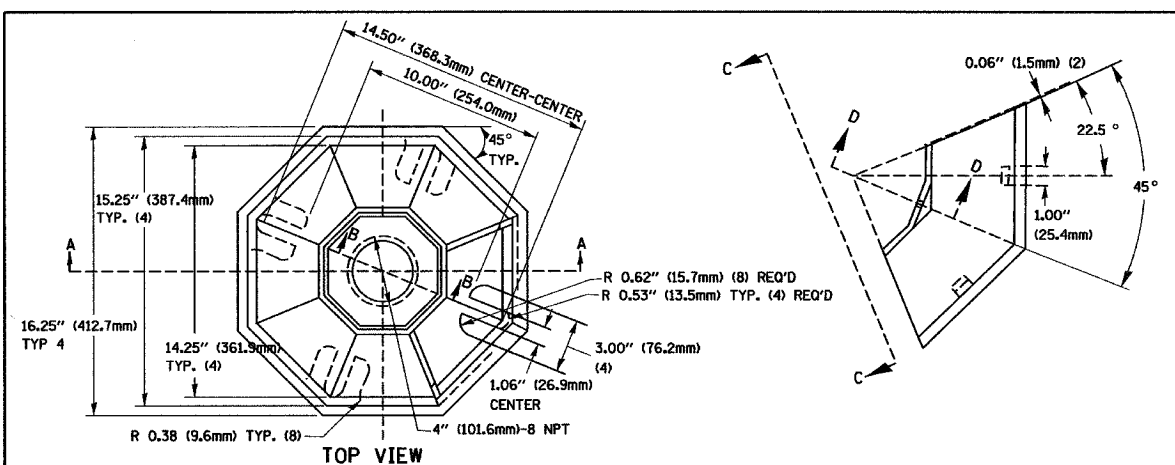

SECTION B-B

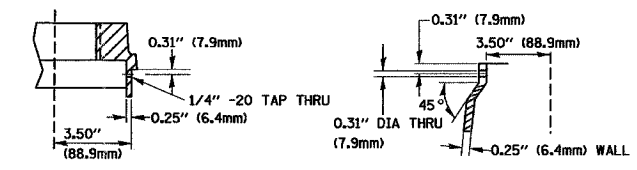

SECTION D-D

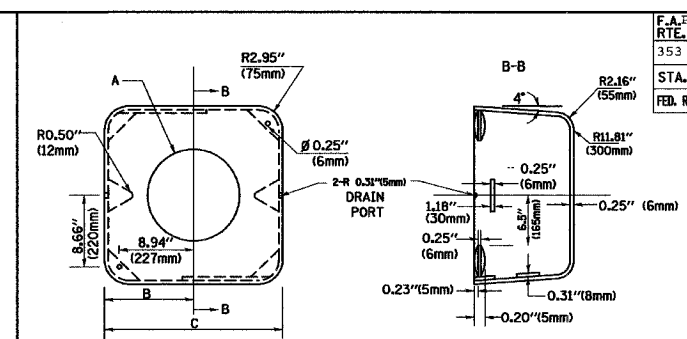

TYPE	A	B	C	HEIGHT	WEIGHT
I	Ø 10.125\"(257mm)	9.5\"(241mm)	19\"(483mm)	12\"(300mm)	24kg
II	Ø 11.125\"(283mm)	10.75\"(273mm)	21.5\"(546mm)	12\"(300mm)	26kg

SHROUD DETAIL

MATERIAL:
 - ASTM A48 CLASS 30 GREY IRON
 - ASTM A123 HOT DIPPED GALVANIZED

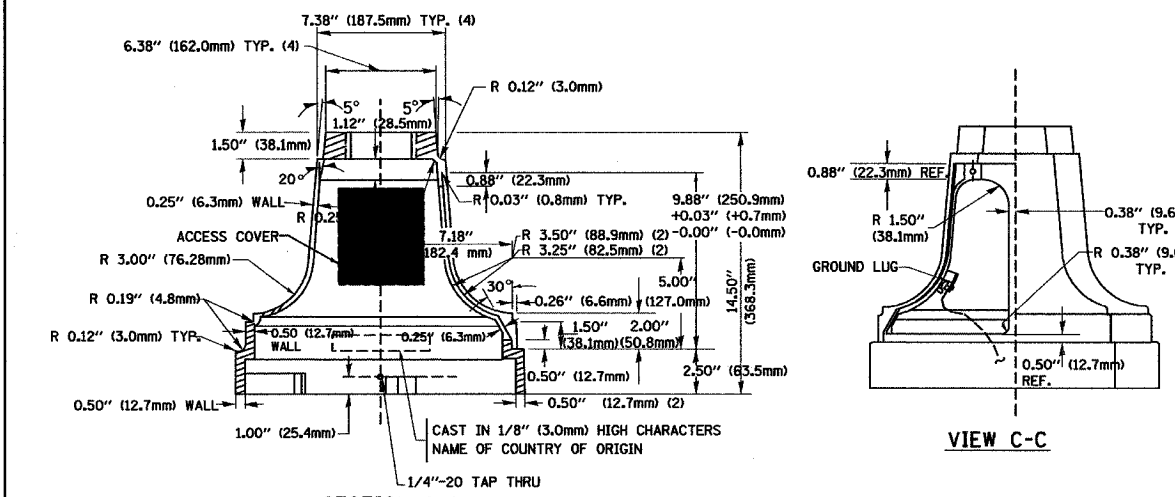

VIEW C-C

TRAFFIC SIGNAL POST - MOUNTING BASE - TYPE A

NOTE:
 SUPPORT EXISTING CABINET AND CONTROL EQUIPMENT ABOVE FOUNDATION TO KEEP TRAFFIC SIGNAL FUNCTIONING WHILE FOUNDATION MODIFICATION WORK IS PROCEEDING.

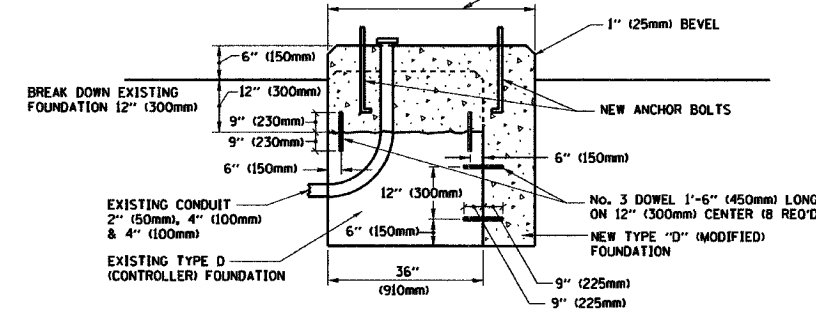

MODIFY EXISTING TYPE "D" FOUNDATION

(NOT TO SCALE)

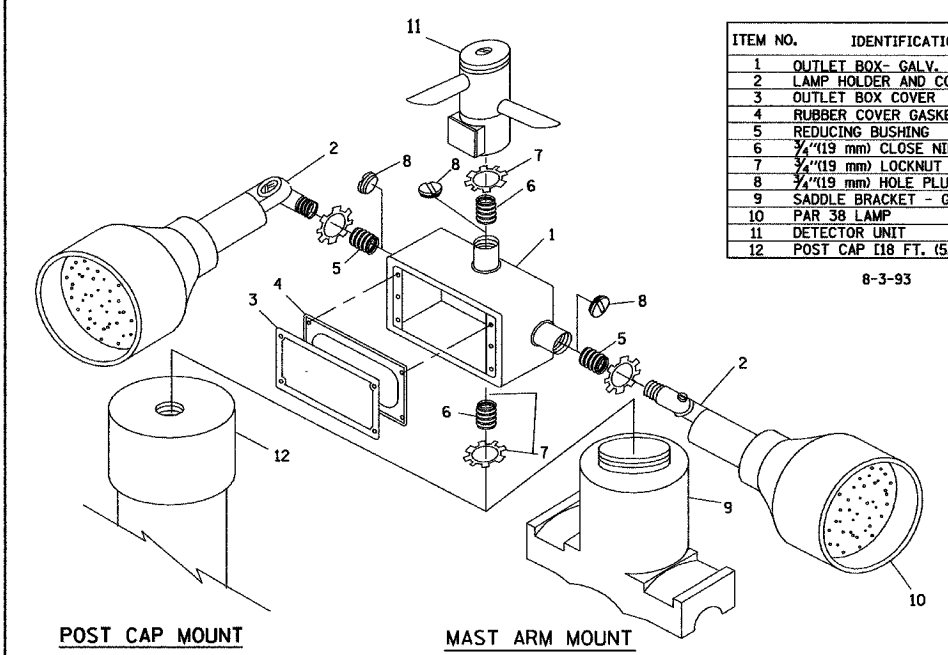

ITEM NO.	IDENTIFICATION
1	OUTLET BOX - GALV. 21 CU. IN. (0.000344 CU-M)
2	LAMP HOLDER AND COVER
3	OUTLET BOX COVER
4	RUBBER COVER GASKET
5	REDUCING BUSHING
6	3/4\"(19 mm) CLOSE NIPPLE
7	3/4\"(19 mm) LOCKNUT
8	3/4\"(19 mm) HOLE PLUG
9	SADDLE BRACKET - GALV.
10	PAR 38 LAMP
11	DETECTOR UNIT
12	POST CAP [18 FT. (5.4 m) POST MIN.]

NOTES:

- ALL ELECTRICAL ITEMS, EXCEPT ITEMS #2 AND #11 SHALL BE ALUMINUM OR GALVANIZED
- ITEM #1- OZ/GEDNEY FSX-1-50 OR EQUIVALENT
 ITEM #2- MULBERRY CON-O-SHADE LAMP SHIELD OR EQUIVALENT
 ITEM #9- "BAND-IT" SADDLE BRACKET OR EQUIVALENT
- WHEN POST MOUNTING IS SPECIFIED, ITEM #9 SHALL NOT BE REQUIRED. THE DETECTION UNIT SHALL BE MOUNTED DIRECTLY ON TOP OF THE CAP BY DRILLING AND TAPPING A 3/4\"(19 mm) HOLE WITH PIPE THREADS. THE POST CAP SHALL EITHER BE SCREWED TO THE TOP OF THE POST OR A MINIMUM OF 3 TIGHTENING SCREWS SHALL BE REQUIRED ON EACH CAP.

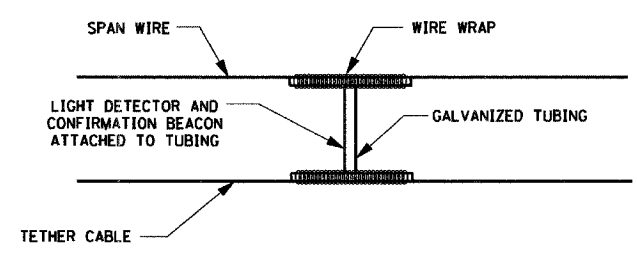

LIGHT DETECTOR AND CONFIRMATION BEACON MOUNTING FOR TEMPORARY TRAFFIC SIGNALS

(NOT TO SCALE)

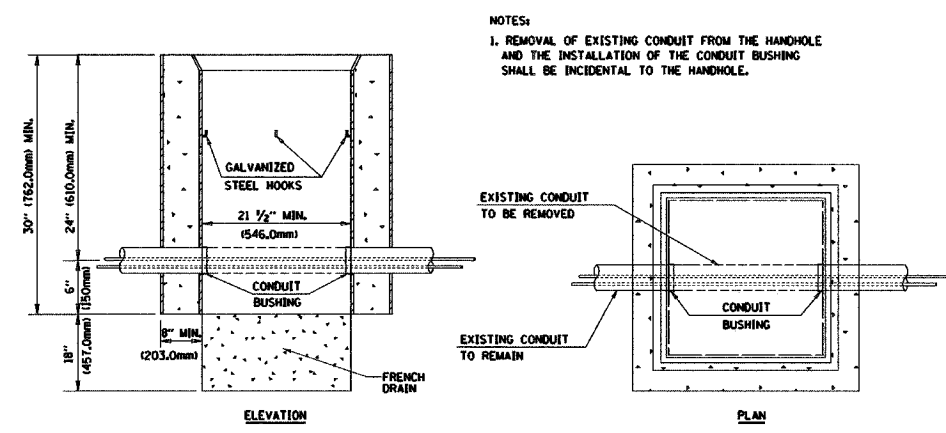

DETAIL HANDHOLE TO INTERCEPT EXISTING CONDUIT N.T.S.

REVISIONS	
NAME	DATE
BUREAU OF TRAFFIC	5/30/00
BUREAU OF TRAFFIC	3/15/01
BUREAU OF TRAFFIC	11/12/01
BUREAU OF TRAFFIC	1-01-02

ILLINOIS DEPARTMENT OF TRANSPORTATION
 DISTRICT ONE
 STANDARD TRAFFIC SIGNAL
 DESIGN DETAILS

SCALE: NONE

DRAWN BY: RWP
 DESIGNED BY: DAD
 CHECKED BY: DAZ
 SHEET 4 OF 4

TS05

DATE: 8/7/2007
 NAME: RWP
 SCALE: 1/8\"/>