

F.A.P. RT.:	SECTION	COUNTY	TOTAL SHEETS	SHEET NO.
338	114R-1	WILL	355	222
STA.	TO STA.			
FED. ROAD DIST. NO.	ILLINOIS FED. AID PROJECT			

MATERIAL:
 - ASTM A48 CLASS 30 GREY IRON
 - ASTM A123 HOT DIPPED GALVANIZED

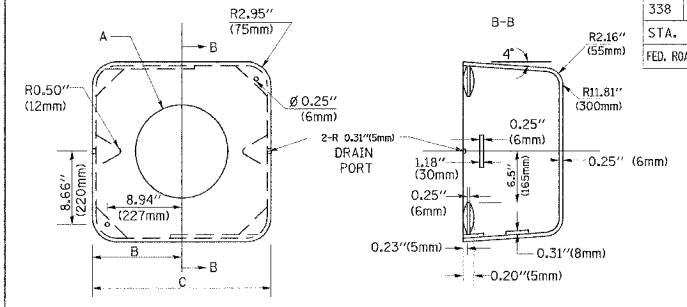

TYPE	A	B	C	HEIGHT	WEIGHT
I	∅ 10.125" (257mm)	9.5" (241mm)	19" (483mm)	12" (300mm)	24kg
II	∅ 11.125" (283mm)	10.75" (273mm)	21.5" (546mm)	12" (300mm)	26kg

SHROUD DETAIL

NOTE:
 SUPPORT EXISTING CABINET AND CONTROL EQUIPMENT ABOVE FOUNDATION TO KEEP TRAFFIC SIGNAL FUNCTIONING WHILE FOUNDATION MODIFICATION WORK IS PROCEEDING.

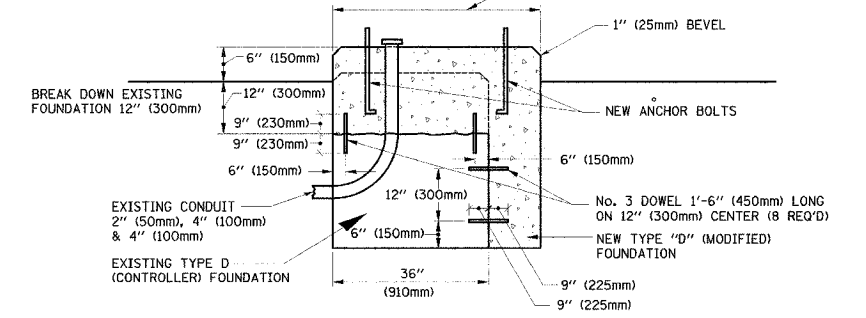

MODIFY EXISTING TYPE "D" FOUNDATION

(NOT TO SCALE)

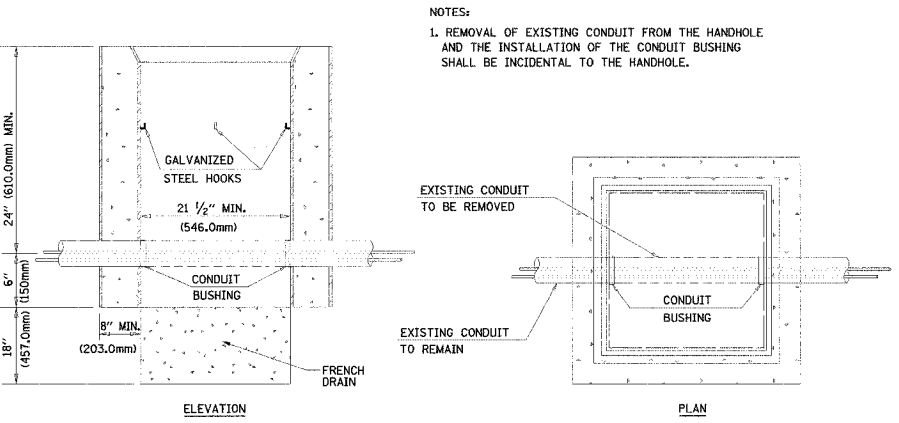

DETAIL
 HANDHOLE TO INTERCEPT EXISTING CONDUIT
 N.T.S.

REVISIONS	
NAME	DATE

ILLINOIS DEPARTMENT OF TRANSPORTATION
 DISTRICT 1
 STANDARD TRAFFIC SIGNAL
 DESIGN DETAILS

SCALE: VERT. NONE
 HORIZ. 1-01-02
 DATE 1-01-02
 DRAWN BY: RWP
 DESIGNED BY: DAD
 CHECKED BY: DAZ
 SHEET 4 OF 4

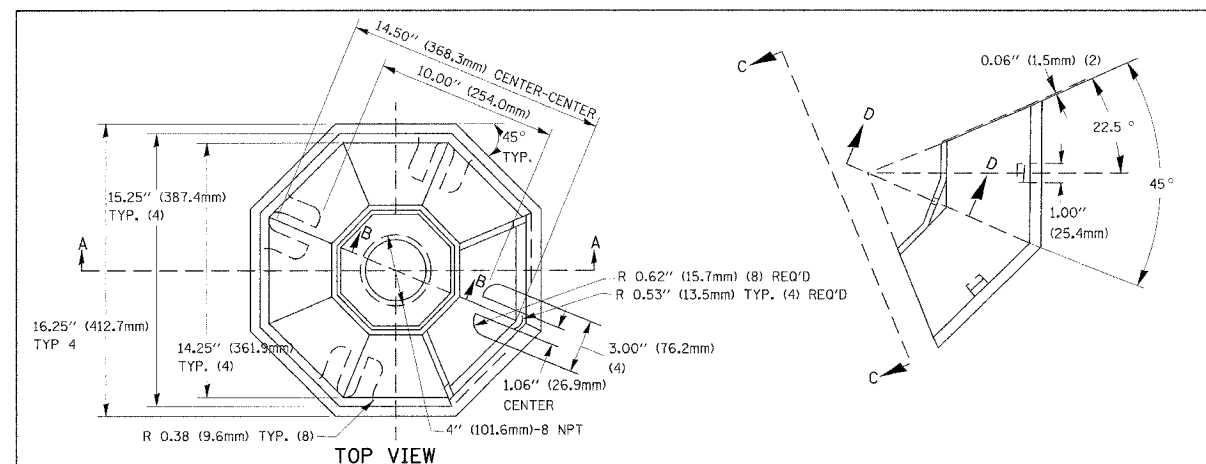

TOP VIEW

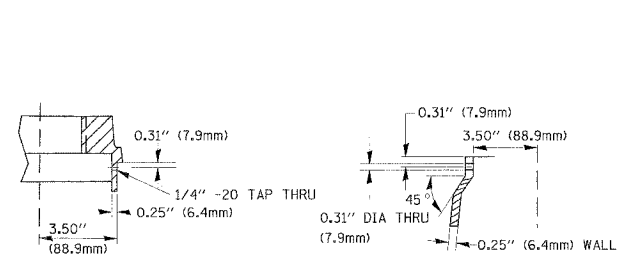

SECTION B-B

SECTION D-D

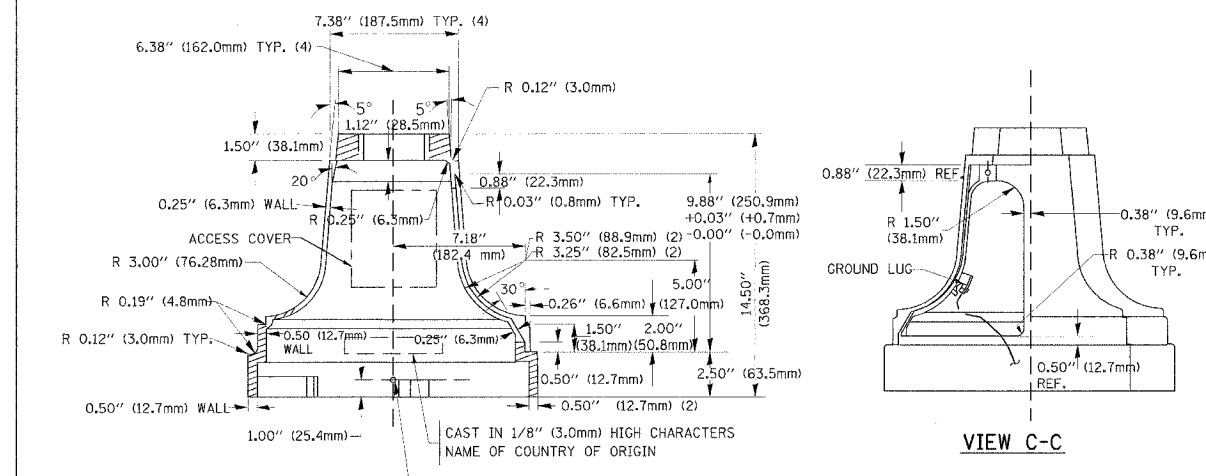

SECTION A-A

VIEW C-C

TRAFFIC SIGNAL POST - MOUNTING BASE - TYPE A

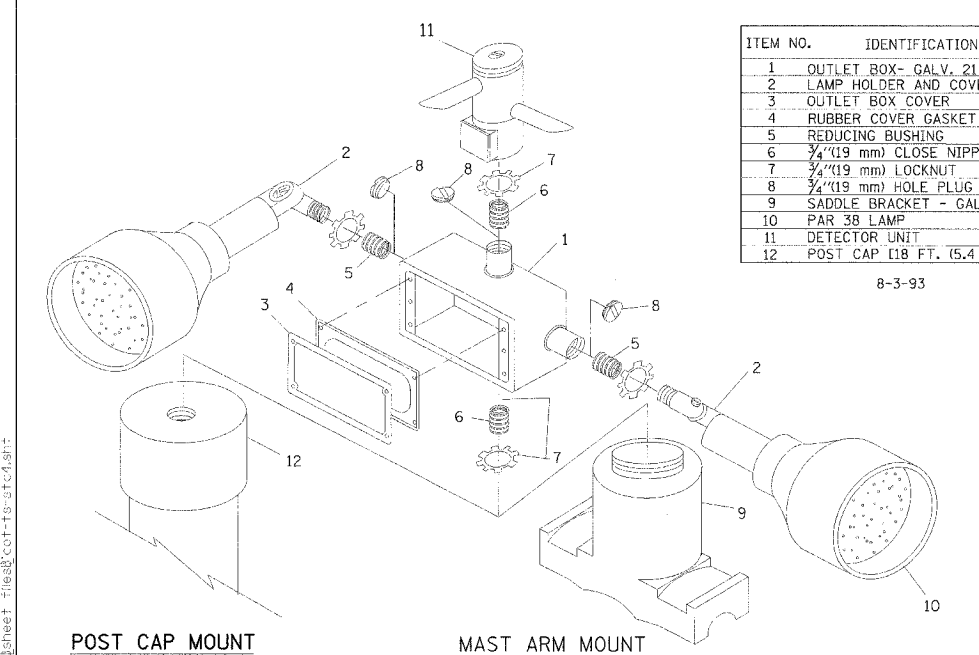

EMERGENCY VEHICLE DETECTOR WITH CONFIRMATION BEACON MOUNTING DETAIL

ITEM NO.	IDENTIFICATION
1	OUTLET BOX - GALV. 21 CU.IN. (0.000344 CU-M)
2	LAMP HOLDER AND COVER
3	OUTLET BOX COVER
4	RUBBER COVER GASKET
5	REDUCING BUSHING
6	3/4" (19 mm) CLOSE NIPPLE
7	3/4" (19 mm) LOCKNUT
8	3/4" (19 mm) HOLE PLUG
9	SADDLE BRACKET - GALV.
10	PAR 38 LAMP
11	DETECTOR UNIT
12	POST CAP [18 FT. (5.4 m) POST MIN.]

8-3-93

NOTES:

- ALL ELECTRICAL ITEMS, EXCEPT ITEMS #2 AND #11 SHALL BE ALUMINUM OR GALVANIZED
- ITEM #1- OZ/GEDNEY FSX-1-50 OR EQUIVALENT
 ITEM #2- MULBERRY CON-O-SHADE LAMP SHIELD OR EQUIVALENT
 ITEM #9- "BAND-IT" SADDLE BRACKET OR EQUIVALENT
- WHEN POST MOUNTING IS SPECIFIED, ITEM #9 SHALL NOT BE REQUIRED. THE DETECTION UNIT SHALL BE MOUNTED DIRECTLY ON TOP OF THE CAP BY DRILLING AND TAPPING A 3/4" (19 mm) HOLE WITH PIPE THREADS. THE POST CAP SHALL EITHER BE SCREWED TO THE TOP OF THE POST OR A MINIMUM OF 3 TIGHTENING SCREWS SHALL BE REQUIRED ON EACH CAP.

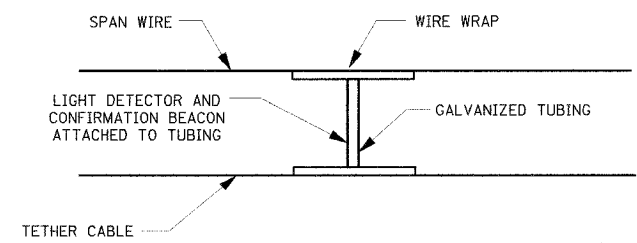

LIGHT DETECTOR AND
 CONFIRMATION BEACON MOUNTING
 FOR TEMPORARY TRAFFIC SIGNALS
 (NOT TO SCALE)

0:\B01021\000218-cod\sheet1-fieal\cot-rs-utcr4.shp
 BA-1.LMC*
 DGN-SPEC