

F. A. S. NO.	SECTION	COUNTY	TOTAL SHEETS	SHEET NO.
2947	08-00148-00-RS	COOK	011	009
STA.		TO STA.		
FED. ROAD DIST. NO.	ALMOST	FED. AID PROJECT		

CONTRACT #63044

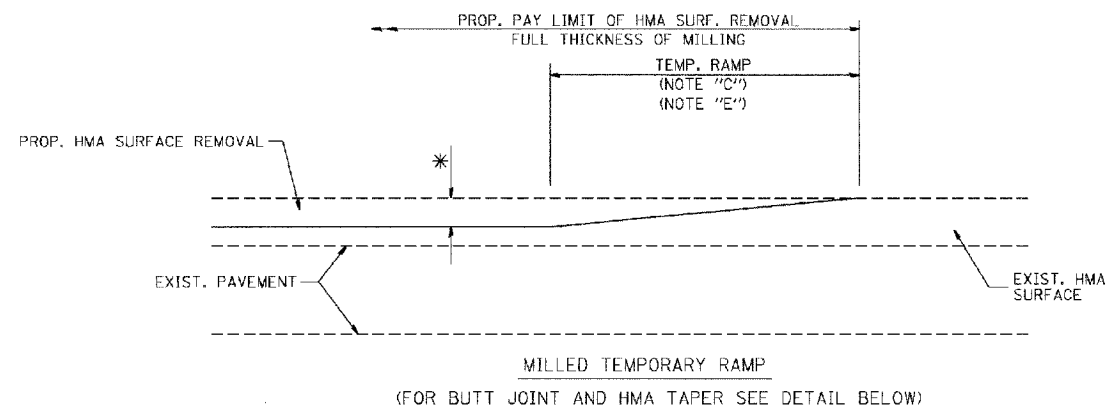

OPTION 1

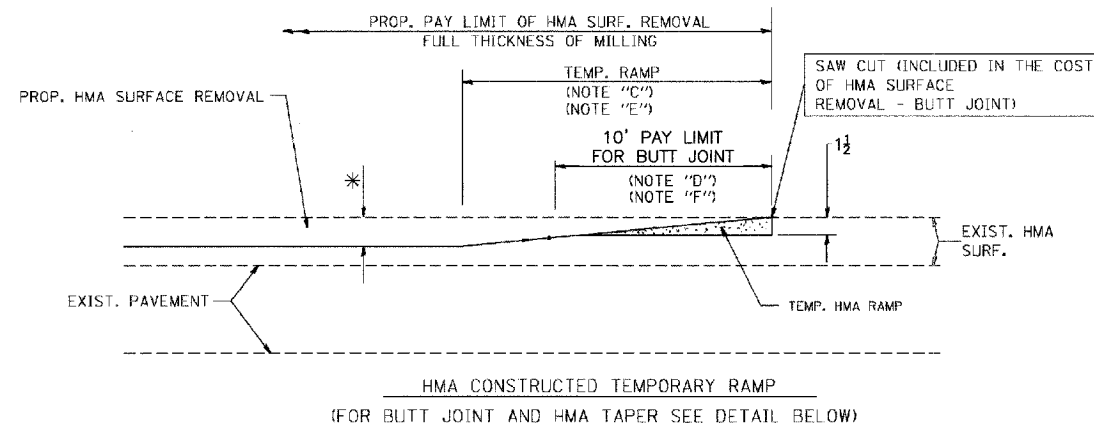

OPTION 2

TYPICAL TEMPORARY RAMP

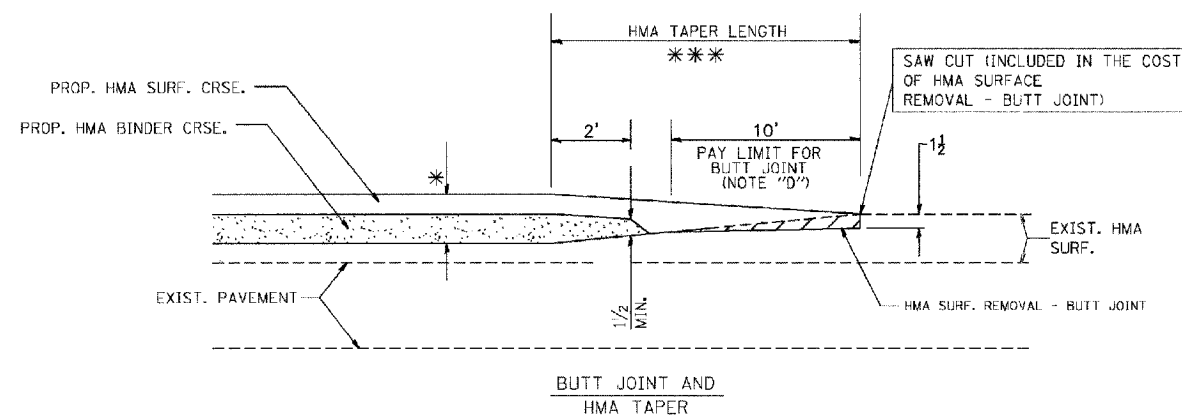

TYPICAL BUTT JOINT AND HMA TAPER FOR MILLING AND RESURFACING

- NOTES
- A: MAINLINE ROADWAYS AND MAJOR SIDE ROADS
 - B: MINOR SIDE ROADS
 - C: THE TEMP RAMP SHALL BE CONSTRUCTED IMMEDIATELY UPON REMOVAL OF THE EXISTING HMA SURFACE.
 - D: THE BUTT JOINT SHALL BE CONSTRUCTED IMMEDIATELY PRIOR TO PLACING THE PROPOSED HMA COURSES.
 - E: TAPER THE TEMP RAMP AT A RATE OF 3'-0" (900 mm) PER 1 INCH (25 mm) OF MILLING THICKNESS
 - F: INSTALLATION AND REMOVAL OF THE 10' TEMP RAMP IS INCLUDED IN THE COST OF HMA SURFACE REMOVAL - BUTT JOINT
- * SEE TYPICAL SECTIONS FOR MILLING THICKNESS
- *** 20'-0" PER 1 RESURFACING (NOTE "A")
10'-0" PER 1 RESURFACING (NOTE "B")

REVISIONS	
NAME	DATE

ILLINOIS DEPARTMENT OF TRANSPORTATION

STATELINE ROAD
ROADWAY RESURFACING
CONSTRUCTION DETAILS

SCALE: VERT. NA
HORIZ. NA
DATE 04/23/08

DRAWN BY RG
CHECKED BY RW