

STATE OF ILLINOIS  
DEPARTMENT OF TRANSPORTATION

CONTRACT: 78040  
ROUTE: F.A.I. 57  
SECTION: (02-1B-1)P-1  
COUNTY: ALEXANDER, IL; MISSISSIPPI, MO  
SHEET 54 OF 67  
FOR INFORMATION ONLY

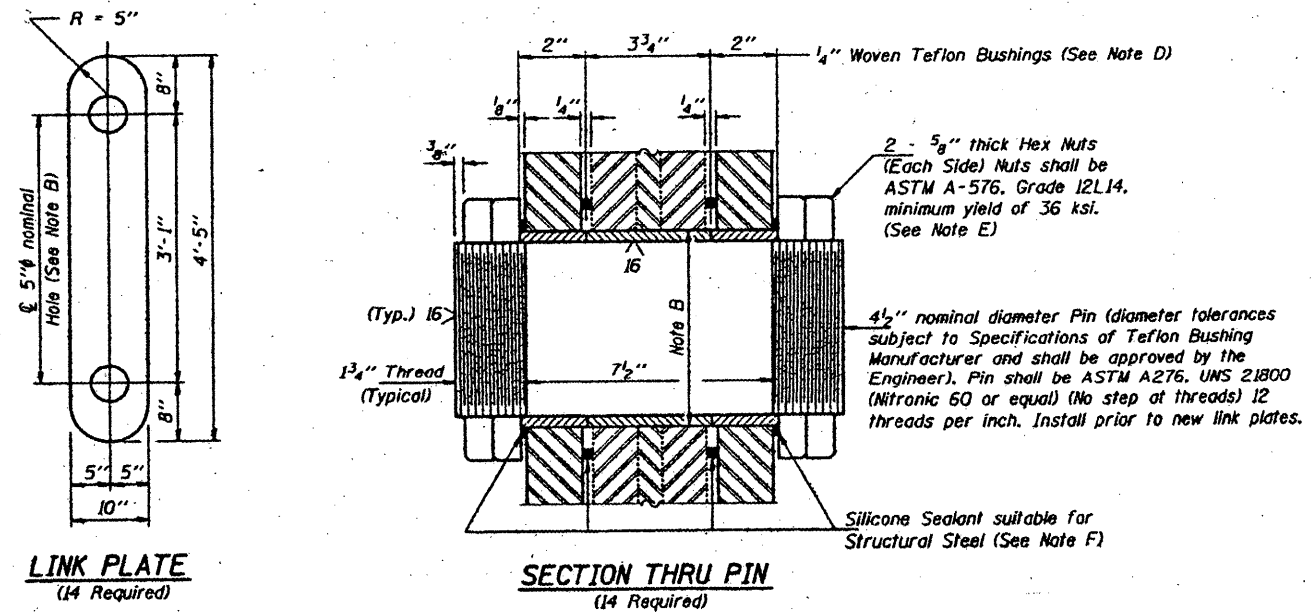
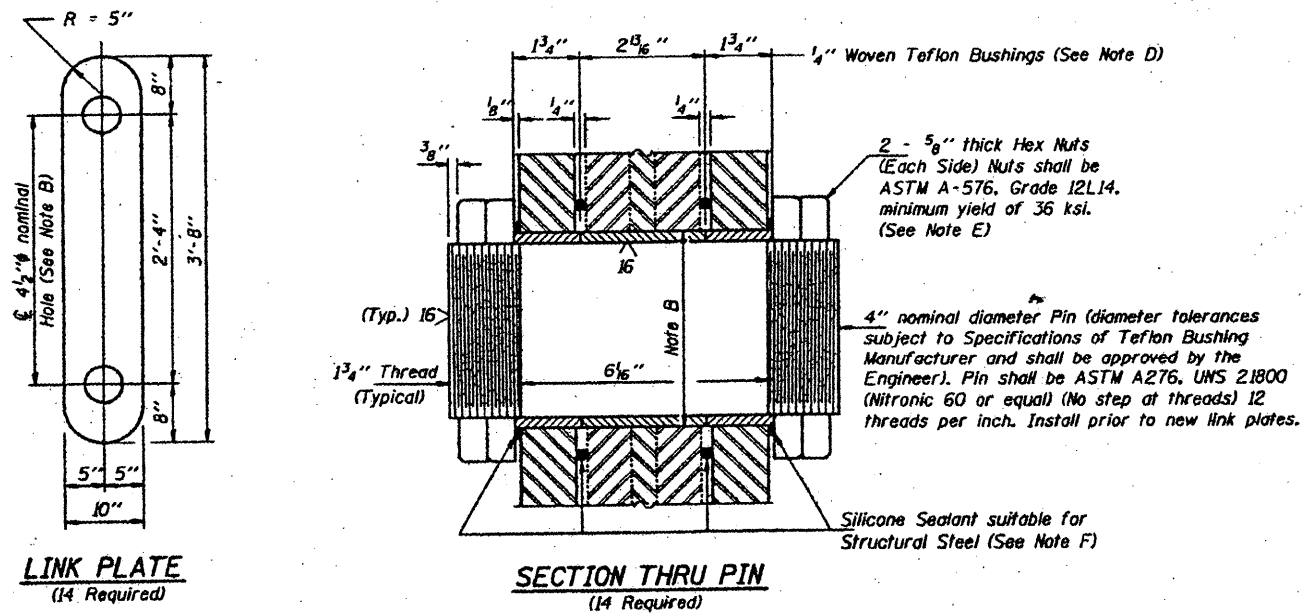
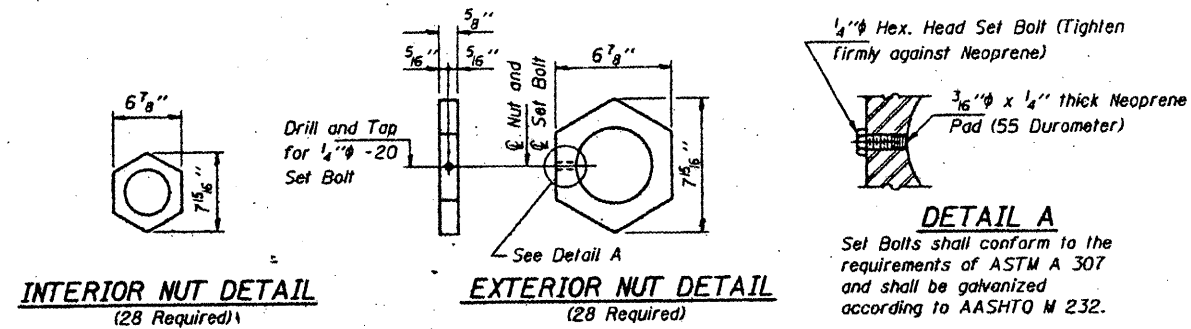
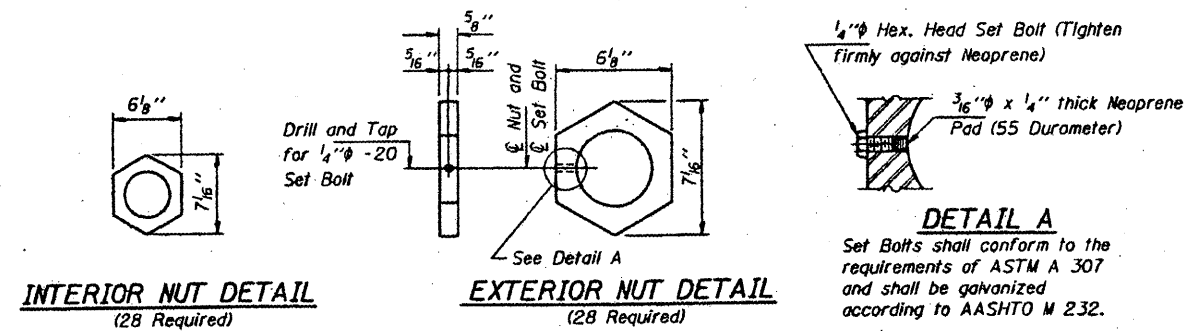

**PIN ASSEMBLY SPAN 4**

**PIN ASSEMBLY SPAN 7**

Notes: For notes A thru G see sheet 2 of 13.

DESIGNED	VHV
CHECKED	CME
DRAWN	Paul Summer
CHECKED	VHV CME

FEBRUARY 19, 1998  
EXAMINED *Joseph E. Adams*  
PASSED  
ENGINEER OF BRIDGES AND STRUCTURES

BRIDGE NO. 1  
STRUCTURE NO. 002-0022  
FOR INFORMATION ONLY

**PIN AND LINK PLATE REPLACEMENT**  
**SPANS 4 AND 7**  
**F.A.I. ROUTE 57 SEC. 02-1B-1**  
**ALEXANDER COUNTY**  
**STA. 1168+50**  
**STR. No. 002-0022**