

STATE OF ILLINOIS  
DEPARTMENT OF TRANSPORTATION

CONTRACT: 78040  
ROUTE: F.A.I. 57  
SECTION: (02-1B-1)P-1  
COUNTY: ALEXANDER, IL; MISSISSIPPI, MO  
SHEET 61 OF 67  
FOR INFORMATION ONLY

FRONT STOOL SUPPORT SPAN 9A

| Mark | A                                   | B      | C      | D      | E                                   | No. Req'd |
|------|-------------------------------------|--------|--------|--------|-------------------------------------|-----------|
| SA1  | 1'-10 <sup>3</sup> / <sub>8</sub> " | 2'-0"  | 1'-10" | 2'-0"  | 1'-10 <sup>1</sup> / <sub>8</sub> " | 2         |
| SA2  | 1'-10 <sup>1</sup> / <sub>8</sub> " | 1'-10" | 1'-10" | 1'-10" | 2'-2 <sup>1</sup> / <sub>8</sub> "  | 1         |
| SA3  | 2'-2 <sup>1</sup> / <sub>8</sub> "  | 1'-10" | 1'-10" | 1'-10" | 1'-10 <sup>1</sup> / <sub>8</sub> " | 1         |
| SA4  | 1'-10 <sup>1</sup> / <sub>8</sub> " | 2'-0"  | 1'-10" | 2'-0"  | 1'-10 <sup>1</sup> / <sub>8</sub> " | 2         |

FRONT STOOL SUPPORT SPAN 15

| Mark | F                                   | G      | H      | J      | K                                   | No. Req'd |
|------|-------------------------------------|--------|--------|--------|-------------------------------------|-----------|
| SC1  | 1'-10 <sup>3</sup> / <sub>8</sub> " | 2'-0"  | 1'-10" | 2'-0"  | 1'-10 <sup>3</sup> / <sub>8</sub> " | 2         |
| SC2  | 1'-10 <sup>1</sup> / <sub>8</sub> " | 1'-10" | 1'-10" | 1'-10" | 2'-2 <sup>1</sup> / <sub>8</sub> "  | 1         |
| SC3  | 2'-2 <sup>1</sup> / <sub>8</sub> "  | 1'-10" | 1'-10" | 1'-10" | 1'-10 <sup>1</sup> / <sub>8</sub> " | 1         |
| SC4  | 1'-10 <sup>3</sup> / <sub>8</sub> " | 2'-0"  | 1'-10" | 2'-0"  | 1'-10 <sup>3</sup> / <sub>8</sub> " | 2         |

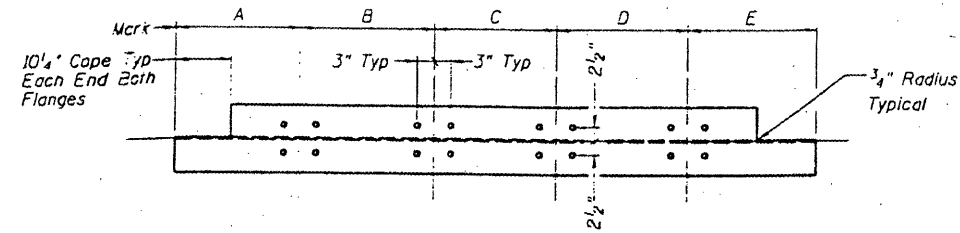

VIEW C-C  
(No opposite hand required)

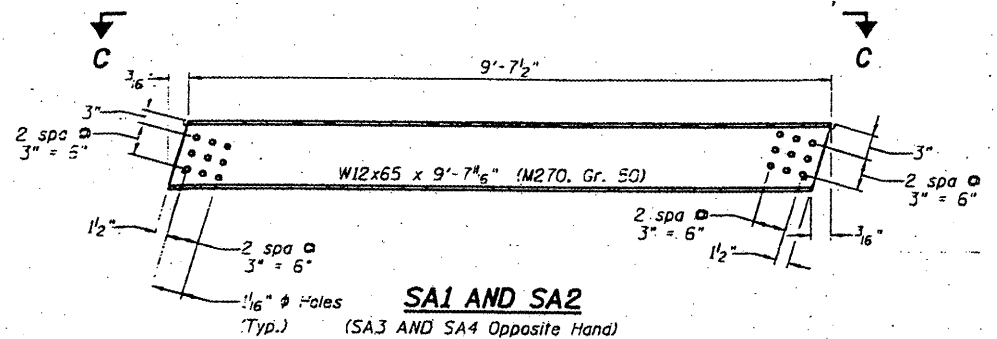

SA1 AND SA2  
(SA3 AND SA4 Opposite Hand)

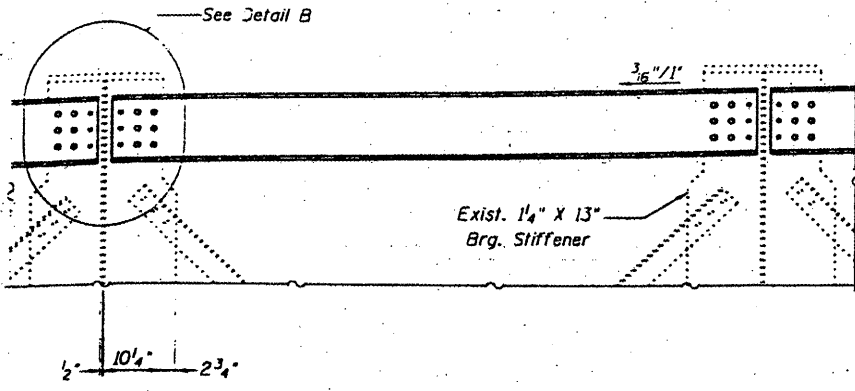

FRONT STOOL SUPPORT - SPAN 9A

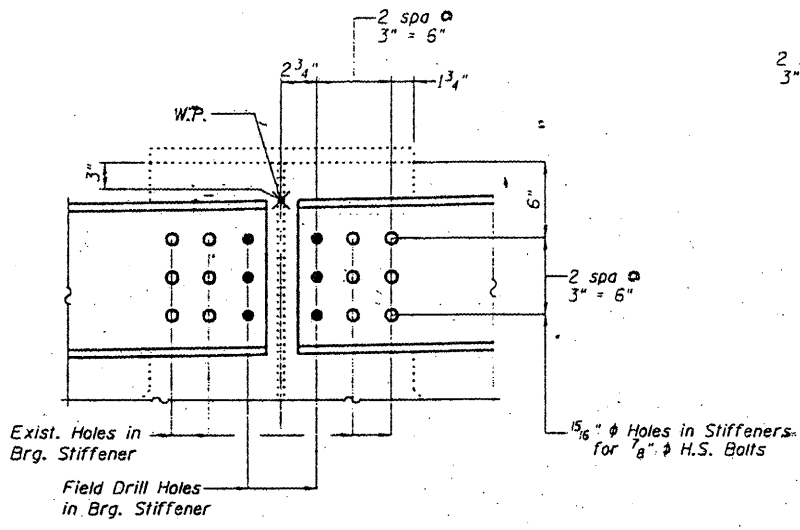

DETAIL B

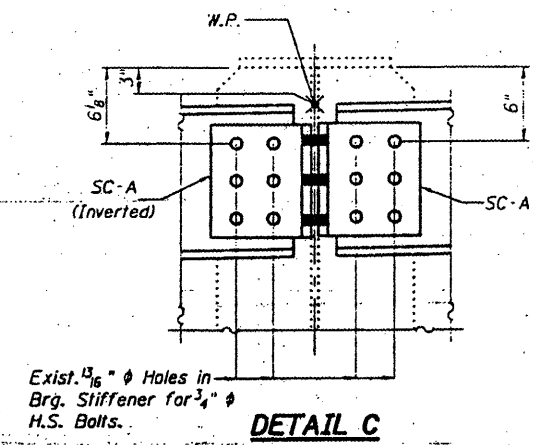

DETAIL C

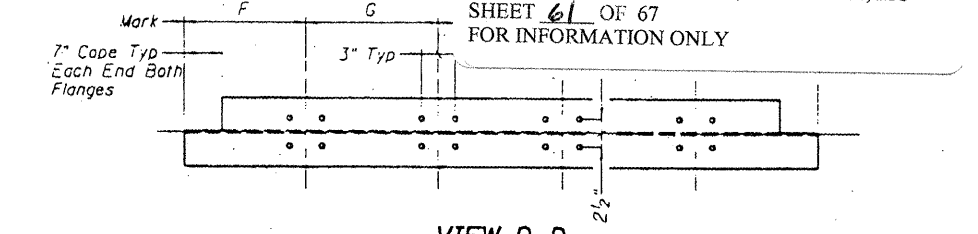

VIEW D-D  
(No opposite hand required)

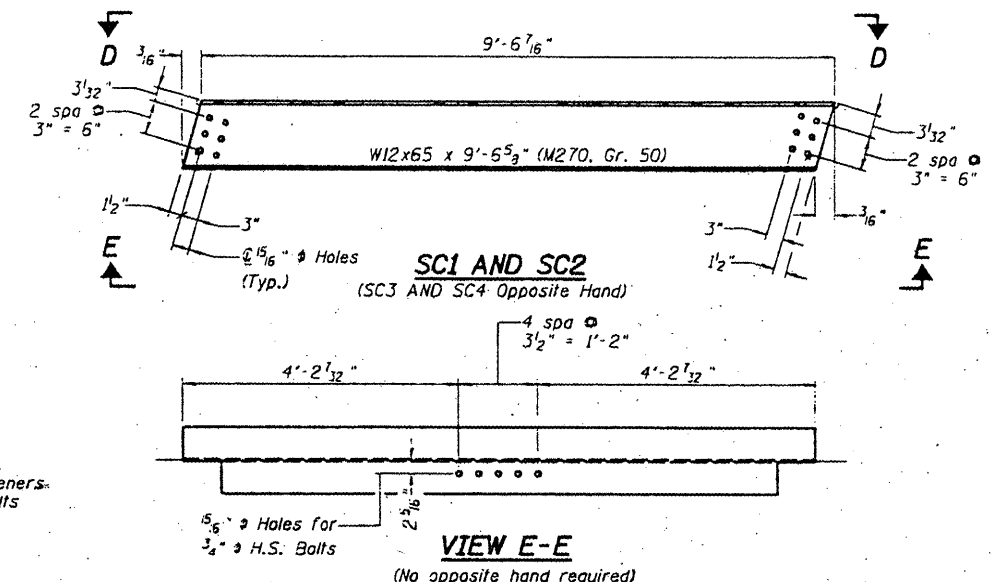

VIEW E-E  
(No opposite hand required)

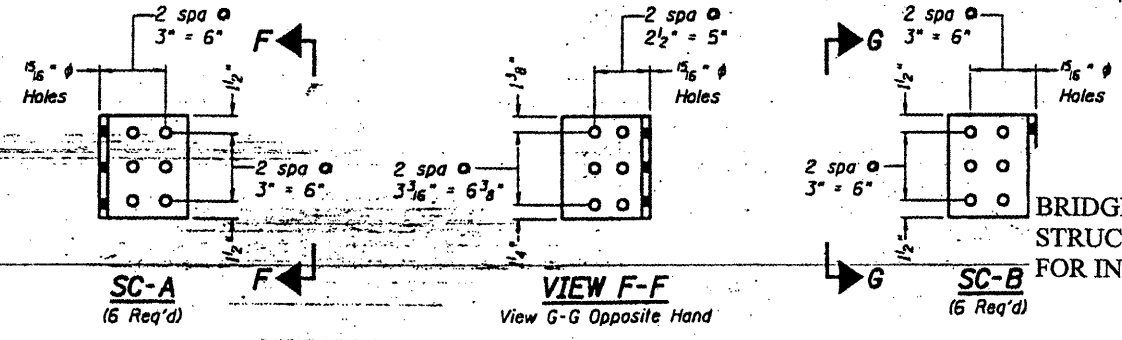
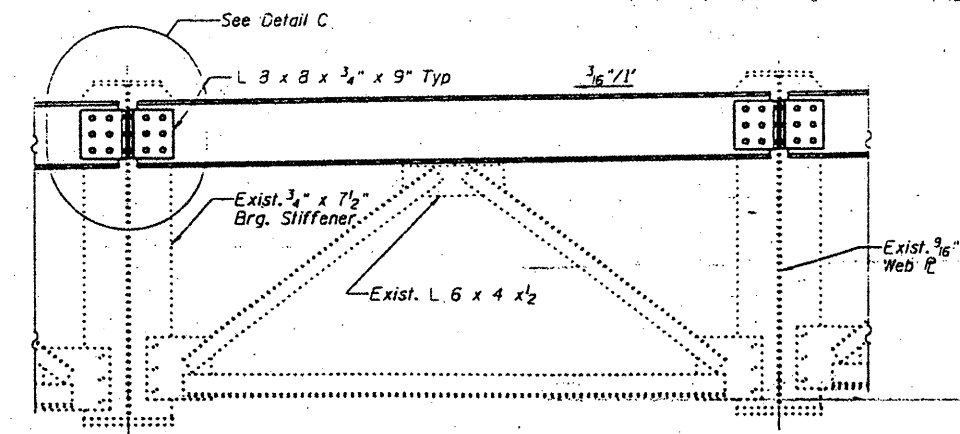

VIEW F-F  
View G-G Opposite Hand

FRONT STOOL SUPPORT - SPAN 15

DESIGNED P.S.J.  
CHECKED A.T.H.  
DRAWN Christopher  
CHECKED A.T.H. P.S.J.

EXAMINED John A. Morris  
ENGINEER OF STRUCTURAL SERVICES  
PASSED  
ENGINEER OF BRIDGES AND STRUCTURES

BRIDGE NO. 1  
STRUCTURE NO. 002-0022  
FOR INFORMATION ONLY

STOOL SUPPORT DETAILS  
F.A.I. 57 OVER MISSISSIPPI RIVER  
ALEXANDER COUNTY  
S.N. 002-0022