

REVISION	DATE	BY

SHELBY COUNTY AIRPORT
SHELBYVILLE, IL

IL PROJ.: 210-3781 A.I.P. PROJ.: 3-17-0083-B8

Hanson No. 827-03THG	ESC	06/19/08
Element R-501TYP.DWG	ESC	06/19/08
Scale N/A		
Date 06/20/08		
LAYOUT	JDW	06/24/08
DRAWN		
REVIEWED		



HANSON
Hanson Professional Services Inc. 2008
1225 South Sixth Street
Springfield, IL 62761
Offices Nationwide

REHABILITATE
T-HANGAR PAVEMENTS
EXISTING AND PROPOSED
TYPICAL
SECTIONS

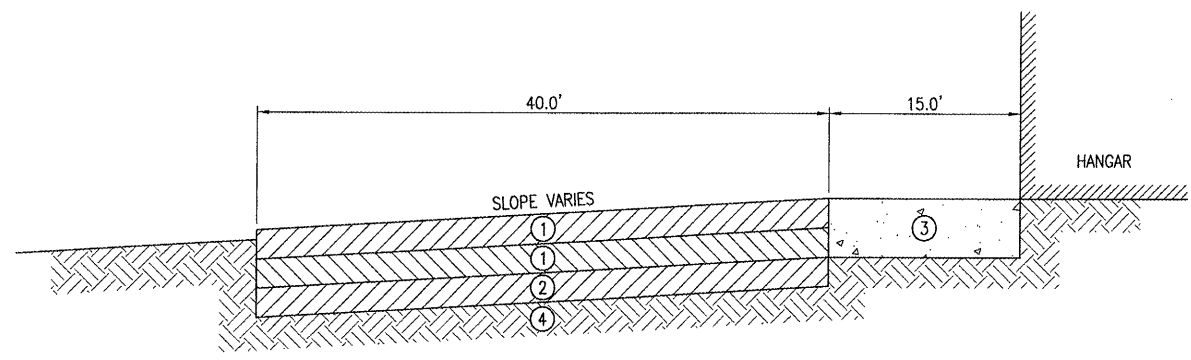

EXISTING TYPICAL SECTION "A-A"
NOT TO SCALE

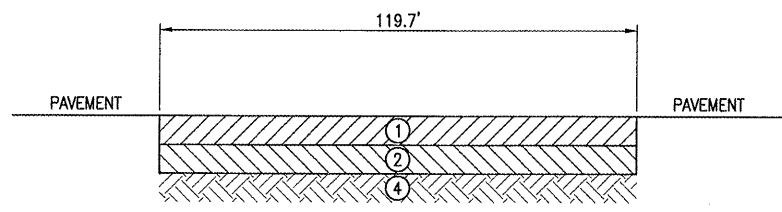

EXISTING TYPICAL SECTION "B-B"
NOT TO SCALE

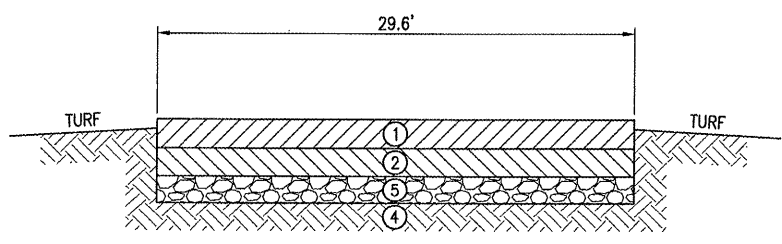

EXISTING TYPICAL SECTION "C-C"
NOT TO SCALE

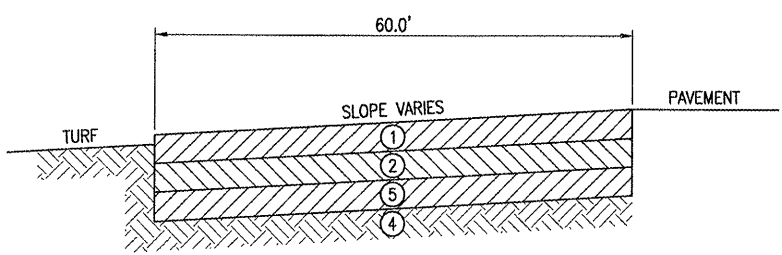

EXISTING TYPICAL SECTION "D-D"
NOT TO SCALE

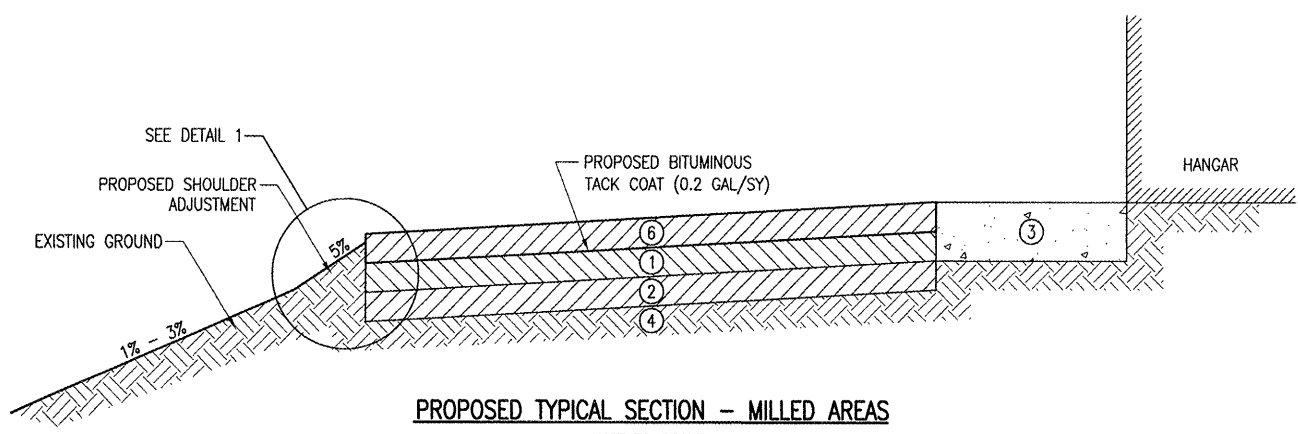

PROPOSED TYPICAL SECTION - MILLED AREAS
NOT TO SCALE

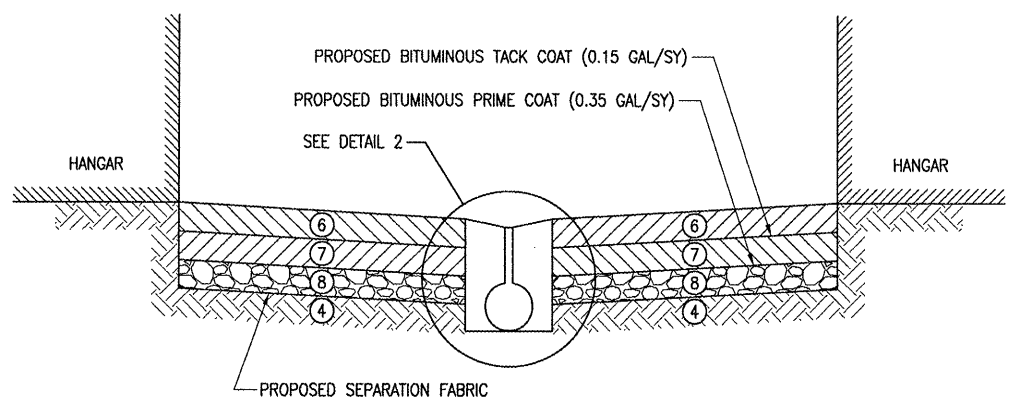

PROPOSED TYPICAL SECTION - NEW PAVEMENT AREA
NOT TO SCALE

LEGEND

- ① EXISTING AR401: BITUMINOUS SURFACE COURSE 2"
- ② EXISTING AR201: BITUMINOUS BASE COURSE 4"
- ③ EXISTING CONCRETE APRON
- ④ EXISTING SUBGRADE
- ⑤ EXISTING AR209: AGGREGATE BASE COURSE 6"
- ⑥ PROPOSED AR401: BITUMINOUS SURFACE COURSE 2"
- ⑦ PROPOSED AR201: BITUMINOUS BASE COURSE 2"
- ⑧ PROPOSED AR209: AGGREGATE BASE COURSE 8"

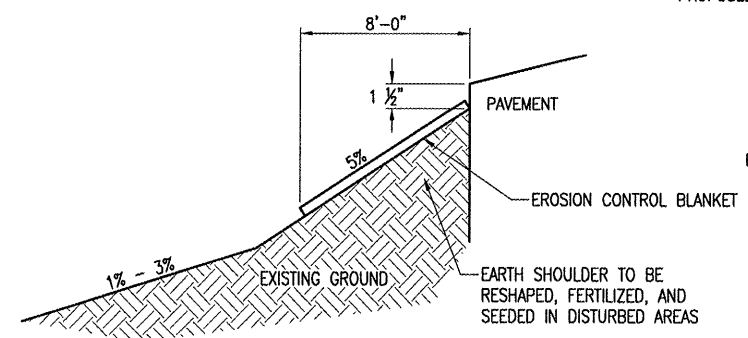

DETAIL 1
NOT TO SCALE

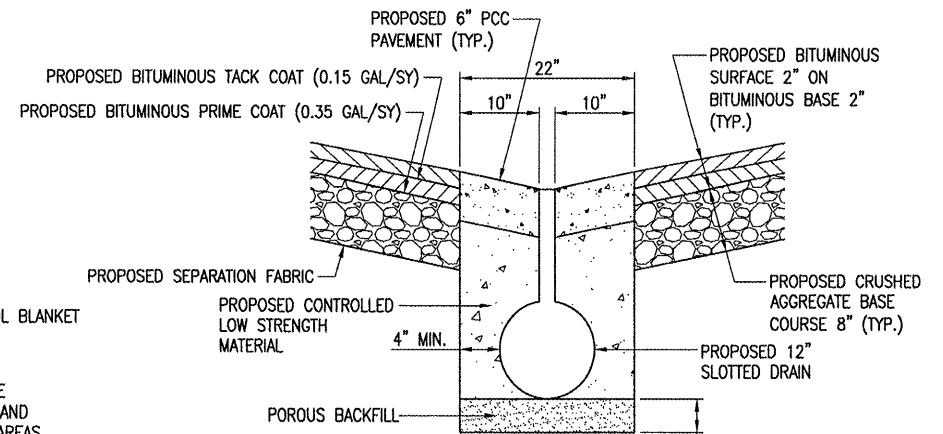

DETAIL 2
NOT TO SCALE

NOTE:
POROUS BACKFILL NO. 1 MATERIAL SHALL CONFORM TO THE REQUIREMENTS FOR IDOT CA-7, CA-14, OR CA-16.

TRENCH DRAIN NOTE

ALL MATERIAL ASSOCIATED WITH THE PROPER INSTALLATION OF THE PROPOSED TRENCH DRAIN IS TO BE INCLUDED IN THE BID UNIT PRICE. THIS INCLUDES CONCRETE, POROUS BACKFILL, CONTROLLED LOW STRENGTH MATERIAL, AND SLOTTED DRAIN AND PIPE.

THE PROPOSED 6" PCC PAVEMENT SHALL BE IN CONFORMANCE WITH ITEM 610 OF THE SPECIFICATIONS.

GENERAL NOTE

CONTRACTOR WILL BE REQUIRED TO EXCAVATE, REWORK, AND RECOMPACT APPROXIMATELY 6 INCHES AND VARIABLE OF EARTH SUBGRADE FOLLOWING THE BITUMINOUS PAVEMENT REMOVAL. EXCAVATION, REWORK, AND RECOMPACTION SHALL BE CONSIDERED INCIDENTAL TO ITEM AR209510, AND NO ADDITIONAL COMPENSATION WILL BE ALLOWED.

JUN 30, 2008 4:14 PM CANN000795
R:\AIRPORTS\SHELBY\827-03THG\DESIGN\CAD\SHEETS\R-501TYP.DWG - Layout1