

EXISTING TYPICAL SECTION  
 MAIN STREET / 142ND STREET  
 STA. 70+00 TO STA. 89+87

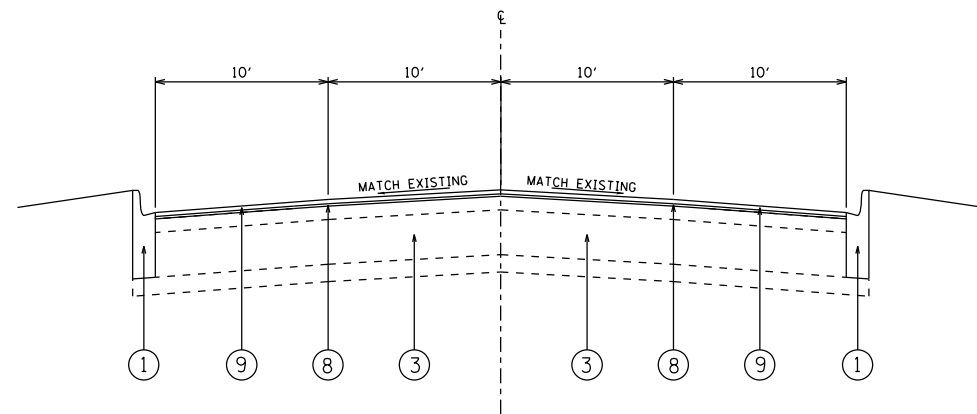

PROPOSED TYPICAL SECTION  
 MAIN STREET / 142ND STREET  
 STA. 70+00 TO STA. 89+87

**LEGEND**

1. EXISTING COMBINATION CONCRETE CURB AND GUTTER, TYPE B 6.12
2. EXISTING P.C. CONCRETE PAVEMENT, ± 10"
3. EXISTING P.C. CONCRETE PAVEMENT, ± 7"
4. EXISTING HMA SURFACE COURSE, ± 3 1/4"
5. EXISTING HMA SURFACE COURSE, ± 4 1/4"
6. EXISTING HMA SURFACE COURSE, ± 6 1/4"
7. PROPOSED HMA SURFACE REMOVAL, 2 1/4"
8. PROPOSED POLYMERIZED LEVELING BINDER (MACHINE METHOD), IL-4.75, N50, 3/4"
9. PROPOSED HMA SURFACE COURSE, MIX "D", N70, 1 1/2"

**NOTES**

CONTRACTOR SHALL MILL FIRST, THEN PATCH.

FILE NAME =	USER NAME = dettmnra	DESIGNED -	REVISED -
es:\pw\work\p\dot\dettmnra\d0255149\010911-shit-plan.dgn	10911-shit-plan.dgn	DRAWN -	REVISED -
Default	PLOT SCALE = 100.0000' / in.	CHECKED -	REVISED -
	PLOT DATE = 5/30/2014	DATE -	REVISED -

**STATE OF ILLINOIS  
 DEPARTMENT OF TRANSPORTATION**

**MAIN ST. (142nd ST.) (INDIANA AVE. TO DOLTON AVE.)  
 EXISTING AND PROPOSED TYPICAL SECTIONS**

SCALE: SHEET 2 OF 2 SHEETS STA. TO STA.

F.A. RTE.	SECTION	COUNTY	TOTAL SHEETS	SHEET NO.
1599	0707-RS-6	COOK	29	7
ILLINOIS FED. AID PROJECT			CONTRACT NO. 60M42	