

EXISTING TYPICAL SECTION

STA 72+42.5 TO STA 130+34
 STA 131+15 TO STA 139+45
 STA 151+04 TO STA 318+09.5
 STA 335+06.5 TO STA 355+82

LEGEND

- ① EXIST. P.C.C. PAVEMENT (VAR. THICKNESS)
- ② EXIST. HOT-MIX ASPHALT PAVEMENT AFTER MILLING ±3.5"
- ③ EXIST. CURB AND GUTTER
- ④ EXIST. HOT-MIX ASPHALT SHOULDER
- ⑤ PROPOSED HOT-MIX ASPHALT SURFACE REMOVAL, 2 1/2"
- ⑥ PROPOSED HOT-MIX ASPHALT SURFACE REMOVAL, 2 1/4"
- ⑦ PROPOSED POLYMERIZED LEVELING BINDER (MACHINE METHOD), IL-4.75, N50, 3/4"
- ⑧ PROPOSED POLYMERIZED LEVELING BINDER (MACHINE METHOD), IL-4.75, N50, 1"
- ⑨ PROPOSED HOT-MIX ASPHALT SURFACE COURSE, MIX "D", N70", 1 1/2"
- ⑩ PROPOSED GRADING AND SHAPING SHOULDERS
- ⑪ PROPOSED AGGREGATE WEDGE SHOULDER, TYPE B

* **NOTE: SHOULDER RESURFACING AND SHOULDER/RUMBLE STRIPS 8" AT THE FOLLOWING STATIONS:**

- STA 85+06 TO STA 89+40
- STA 98+68 TO STA 102+32
- STA 105+60 TO STA 108+10
- STA 114+45 TO STA 117+80
- STA 119+89 TO STA 124+79
- STA 131+08 TO STA 135+77
- STA 137+00 TO STA 139+45
- STA 151+04 TO STA 155+54
- STA 169+89 TO STA 173+30
- STA 178+62 TO STA 182+12
- STA 214+50 TO STA 215+75
- STA 221+75 TO STA 224+30
- STA 229+00 TO STA 232+42
- STA 238+15 TO STA 241+00
- STA 248+60 TO STA 250+80
- STA 252+92 TO STA 255+75
- STA 267+57 TO STA 271+89
- STA 274+35 TO STA 282+85
- STA 285+60 TO STA 291+34
- STA 307+51 TO STA 310+75
- STA 335+06 TO STA 337+50
- STA 342+20 TO STA 346+00

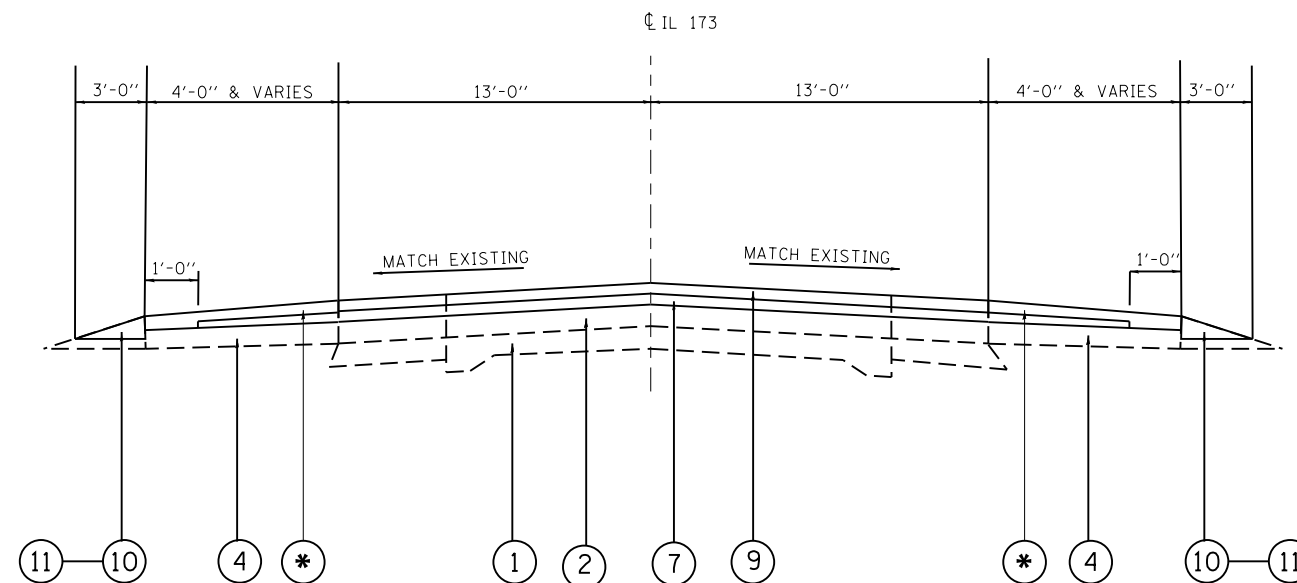

PROPOSED TYPICAL SECTION

STA 72+42.5 TO STA 130+34
 STA 131+15 TO STA 139+45
 STA 151+04 TO STA 318+09.5
 STA 335+06.5 TO STA 355+82

**EXISTING RUMBLE STRIP ON SHOULDER TO REMAIN (TYPICAL)
 NEW RUMBLE STRIP TO BE CONSTRUCTED AS NOTED**

FILE NAME =	USER NAME = osbornnp	DESIGNED -	REVISED -	STATE OF ILLINOIS DEPARTMENT OF TRANSPORTATION	EXISTING AND PROPOSED TYPICAL SECTIONS		F.A.P. RTE.	SECTION	COUNTY	TOTAL SHEETS	SHEET NO.
et:\pw\work\p\dot\osbornnp\d0313225\01912-sht-plan.dgn	PLOT SCALE = 100.0000' / 1in.	DRAWN -	REVISED -				303	(21X,29V&132)RS-2	MCHENRY	34	7
Default	PLOT DATE = 6/11/2014	CHECKED -	REVISED -		SCALE: SHEET OF SHEETS STA. TO STA.		CONTRACT NO. 60V12				
		DATE -	REVISED -		ILLINOIS FED. AID PROJECT						