

**TYPICAL PROPOSED CROSS SECTION
U.S. ROUTE 14**
 STA. 512+14.37 TO STA. 517+63.93
 STA. 535+77.04 TO STA. 552+35.81
 STA. 562+64.41 TO STA. 564+31.33
 STA. 580+32.78 TO STA. 599+00.00

* SEE PGES LIMITS ON SHEET 18
 ** MEDIANS WIDENS TO 30' WIDE AT
 IL 176 INTERSECTION.
 *** DOES NOT INCLUDE EXISTING R.O.W. AND
 STORMWATER DETENTION LOCATIONS.

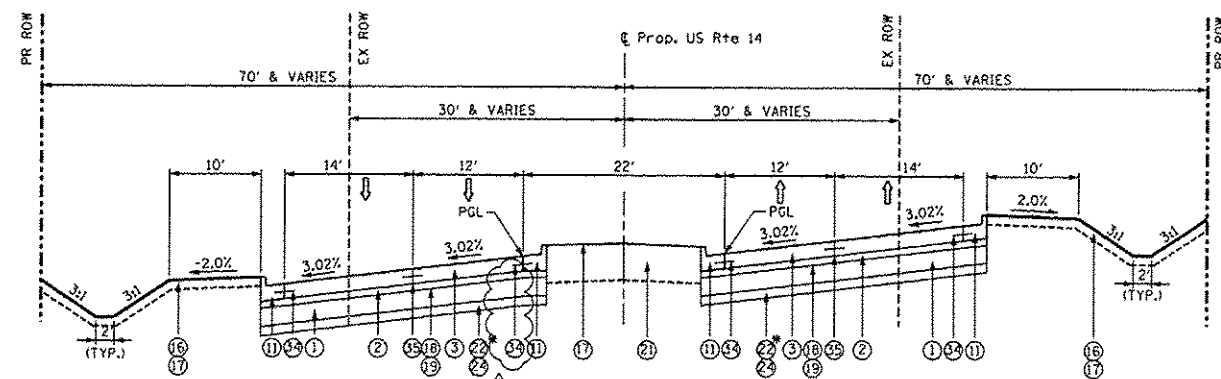

**TYPICAL PROPOSED CROSS SECTION
U.S. ROUTE 14**
 STA. 552+35.81 TO STA. 562+64.41
 * SEE PGES LIMITS ON SHEET 18

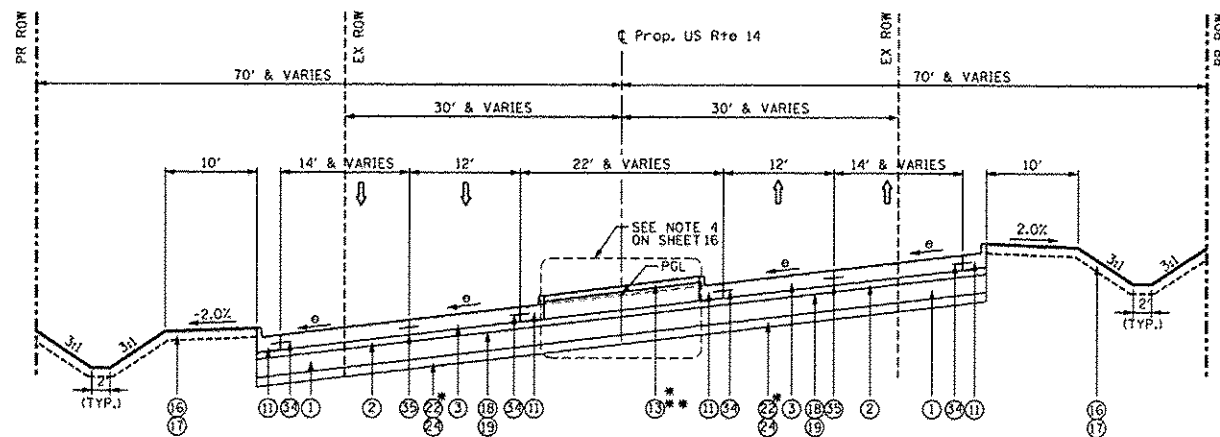

**TYPICAL PROPOSED CROSS SECTION
U.S. ROUTE 14**
 STA. 517+63.93 TO STA. 535+77.04
 STA. 564+31.33 TO STA. 580+32.78

* SEE PGES LIMITS ON SHEET 18
 ** CONCRETE MEDIAN IS BEING SHOWN. SEE LANDSCAPED/CONCRETE MEDIAN
 LIMITS (ABOVE) AND LANDSCAPED MEDIAN DETAIL (BELOW) ON THIS SHEET.

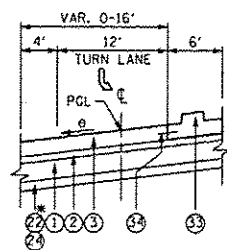

MEDIAN TURNLANE DETAILS
 * SEE PGES LIMITS ON SHEET 18

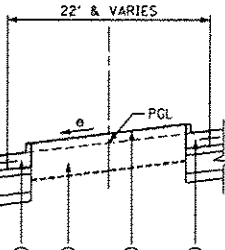
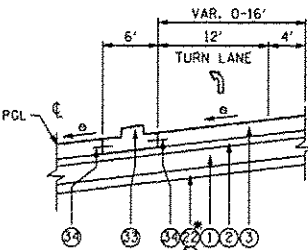

LANDSCAPED MEDIAN DETAIL

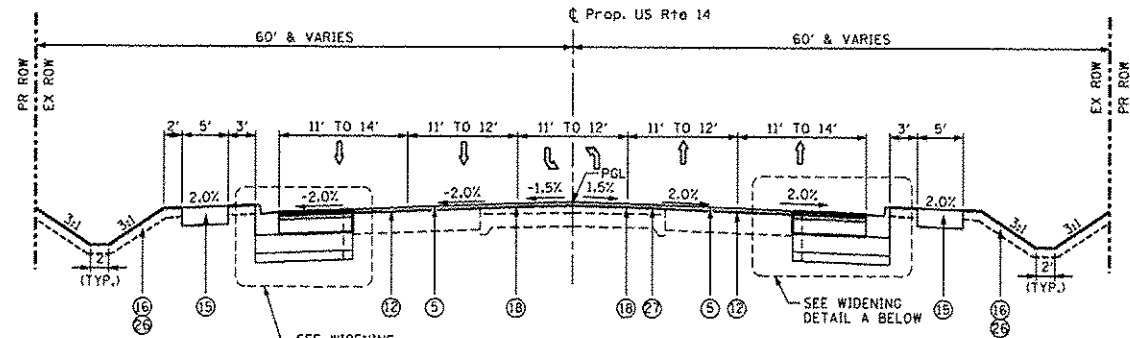

**TYPICAL PROPOSED CROSS SECTION
U.S. ROUTE 14**
 STA. 599+00.00 TO STA. 619+25.58

PROPOSED LEGEND

- 1 AGGREGATE SUBGRADE IMPROVEMENT 12"
- 2 STABILIZED SUBBASE - HOT-MIX ASPHALT, 4 1/2"
- 3 PORTLAND CEMENT CONCRETE PAVEMENT 9 3/4" (JOINTED)
- 4 HOT-MIX ASPHALT SURFACE COURSE, MIX "D", N70, 1 1/2"
- 5 POLYMERIZED HOT-MIX ASPHALT SURFACE COURSE, MIX "F", N90, 1 3/4"
- 6 HOT-MIX ASPHALT PAVEMENT (FULL-DEPTH), 9"
- 7 HOT-MIX ASPHALT SURFACE REMOVAL, 2 1/2"
- 8 HOT-MIX ASPHALT SHOULDERS, 9"
- 9 AGGREGATE SHOULDERS, TYPE B 9"
- 10 COMBINATION CONCRETE CURB AND GUTTER, TYPE B-6.12
- 11 COMBINATION CONCRETE CURB AND GUTTER, TYPE B-6.24
- 12 HOT-MIX ASPHALT SURFACE REMOVAL, 2 1/4"
- 13 CONCRETE MEDIAN SURFACE, 4 INCH
- 14 M.C.C.D. BIKE TRAIL (SEE NOTE 3 ON SHEET 16)
- 15 PORTLAND CEMENT CONCRETE SIDEWALK 5 INCH
- 16 PROPOSED TOPSOIL, 6" (SEE NOTE 6 ON SHEET 16)
- 17 SEEDING, CLASS 2A
- 18 BITUMINOUS MATERIALS (PRIME COAT)
- 19 AGGREGATE (PRIME COAT)
- 20 NOT USED
- 21 TOPSOIL FURNISH AND PLACE, 24"
- 22 POROUS GRANULAR EMBANKMENT
- 23 COURSE AGGREGATE FILL
- 24 REMOVAL AND DISPOSAL OF UNSUITABLE MATERIAL
- 25 ADDITIONAL 1 FOOT PAVEMENT RECONSTRUCTION
- 26 SODDING, SALT TOLERANT
- 27 POLYMERIZED LEVELING BINDER (MACHINE METHOD), IL-4.75, NS0 - 3/4"
- 28 HOT-MIX ASPHALT BASE COURSE WIDENING, 4 1/2"
- 29 HOT-MIX ASPHALT BASE COURSE WIDENING, 9 1/4"
- 30 PORTLAND CEMENT CONCRETE SHOULDERS 9 3/4"
- 31 HOT-MIX ASPHALT BINDER COURSE, IL-19.0, NS0 (2 1/4")
- 32 HOT-MIX ASPHALT BINDER COURSE, IL-19.0, N70 2 1/4"
- 33 CONCRETE MEDIAN, TYPE SB (SPECIAL)
- 34 NO. 6 EPOXY COATED TIE BARS 24" LONG AT 24" CTS
- 35 LONGITUDINAL SAWED JOINT, WITH NO. 6 TIE BARS 30" LONG AT 30" CTS

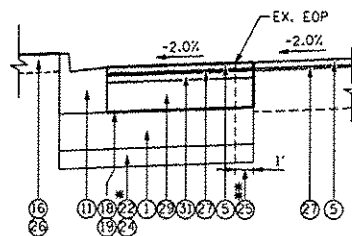

WIDENING DETAIL B
 * SEE PGES LIMITS ON SHEET 18
 ** SEE NOTE 2 ON SHEET 16.

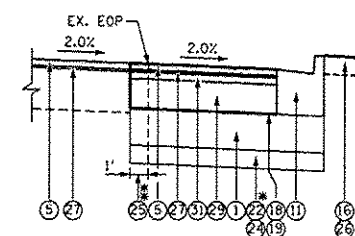

WIDENING DETAIL A
 * SEE PGES LIMITS ON SHEET 18
 ** SEE NOTE 2 ON SHEET 16.

NOTES:

1. UNLESS OTHERWISE NOTED, USE U.S. ROUTE 14 PAVEMENT FOR SIDEROADS.
2. 1' WIDE EXISTING PAVEMENT RECONSTRUCTION IN ADDITION TO THE EXISTING CURB AND GUTTER REMOVAL.

FILE NAME * S:\1626\CADD Sheets\0162517-whr-typical	USER NAME * USERNAME Addendum - V01.dgn	DESIGNED - JPW	REVISED - 7/14/2014 HWL
PLOT SCALE * 20,000 / 1 IN.	CHECKED - MGZ	DRAWN - JPW	REVISED -
PLOT DATE * 7/14/2014	DATE - 10/15/2013		REVISED -

**STATE OF ILLINOIS
DEPARTMENT OF TRANSPORTATION**

**TYPICAL SECTIONS
U.S. ROUTE 14**

SCALE: NONE SHEET NO. 13 OF 431 SHEETS STA. TO STA.

F.A. RTE.	SECTION	COUNTY	TOTAL SHEETS	SHEET NO.
305	27R-3	MCHENRY	431	13
			CONTRACT NO. 62517	
(ILLINOIS) FED. AID PROJECT				