

TYPICAL SECTION NO. 10

STA. 119+66 TO STA. 123+97.1

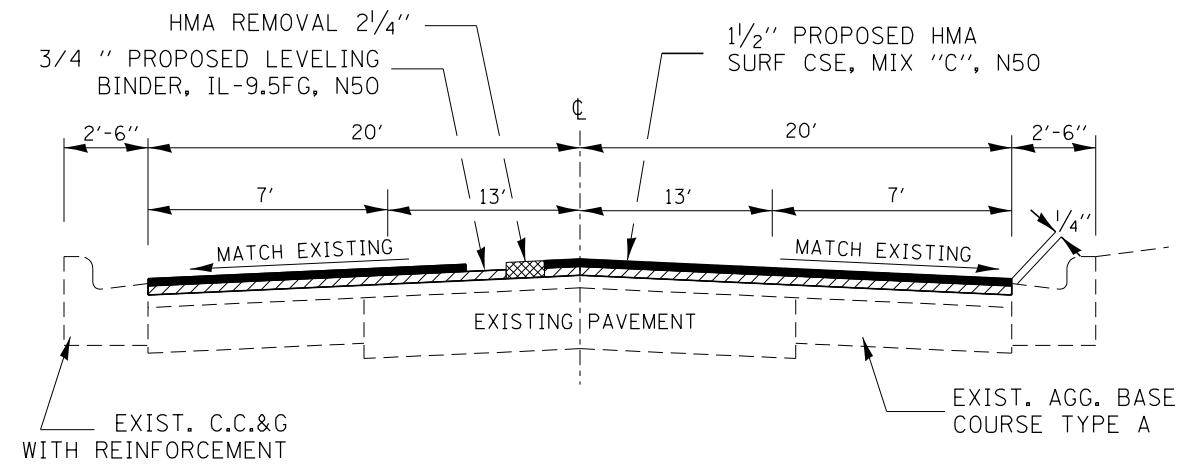

TYPICAL SECTION NO. 11

STA. 123+97.1 TO STA. 127+35

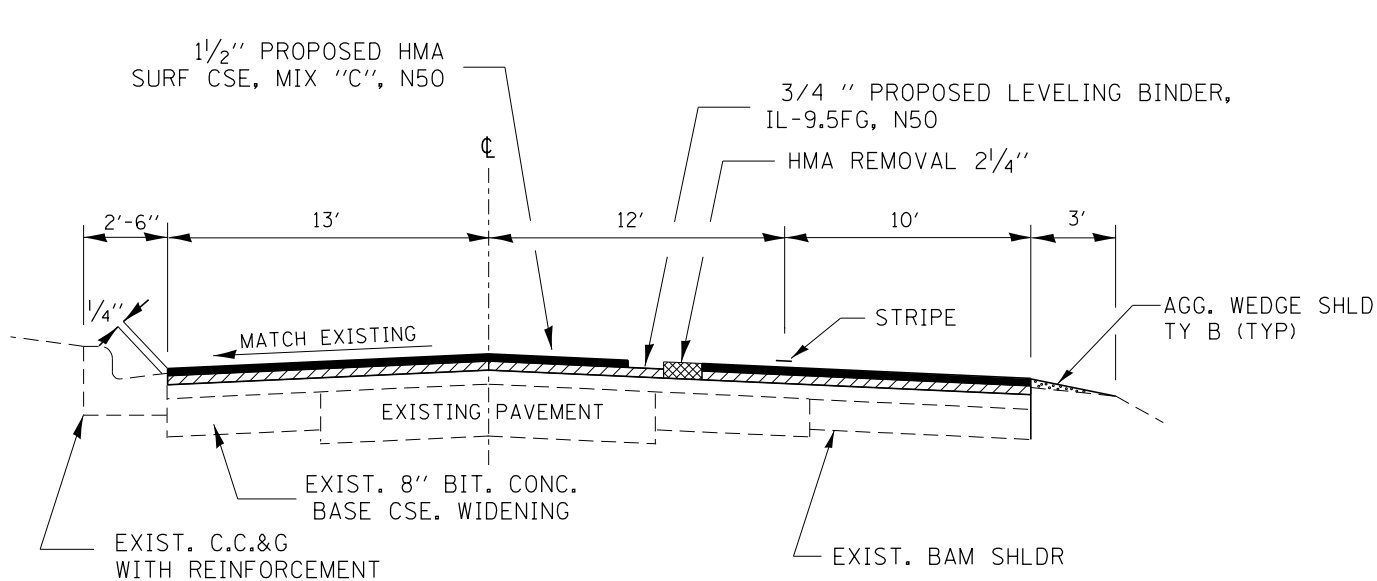

TYPICAL SECTION NO. 12

STA. 135+46 TO STA. 136+60.5

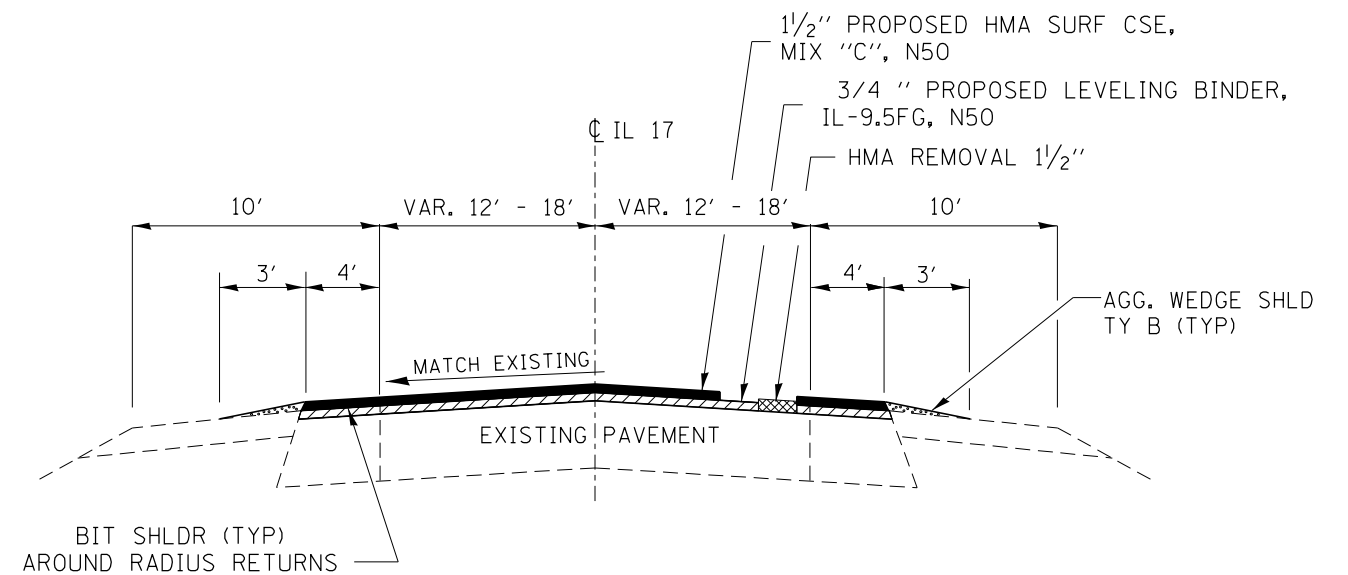

IL 17 SIDEROAD

STA. 329+25 TO STA. 333+50 (IL 17)

FILE NAME = c:\pwork\pwork\dot\schwankerg\d0287863\066885-shd-typicells.dgn	USER NAME = Schwankerg	DESIGNED -	REVISED -	STATE OF ILLINOIS DEPARTMENT OF TRANSPORTATION	TYPICAL SECTIONS			F.A.P. RTE.	SECTION	COUNTY	TOTAL SHEETS	SHEET NO.
	PLOT SCALE = 100.0000' / 1" / 1" / 1"	CHECKED -	REVISED -					68	(101,102)RS-3	LIVINGSTON	22	10
PLOT DATE = 6/6/2014	DATE -	REVISED -	REVISED -	SCALE:	SHEET NO.	OF SHEETS	STA.	TO STA.	CONTRACT NO. 66B85			
										ILLINOIS FED. AID PROJECT		