

TYPICAL PLAN OF MEDIAN ISLAND

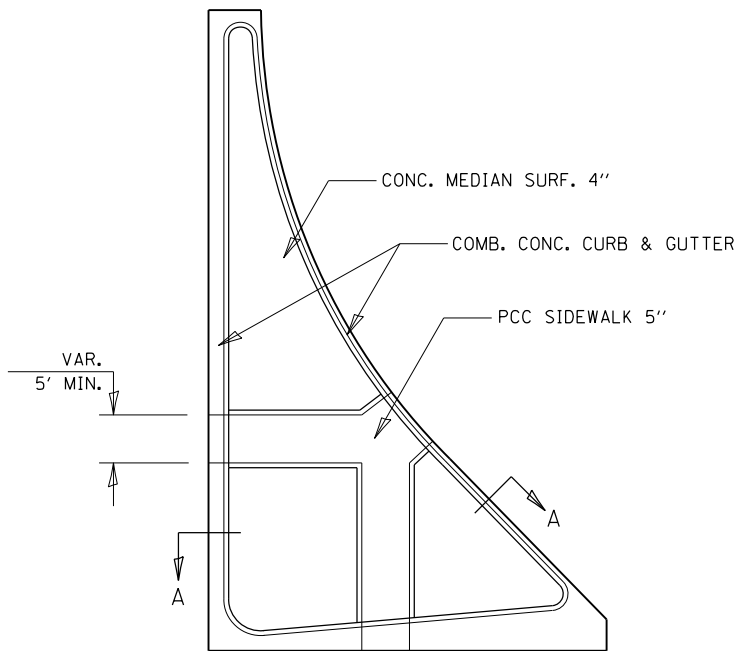

LARGE ISLAND
(FREE FLOW DESIGN)

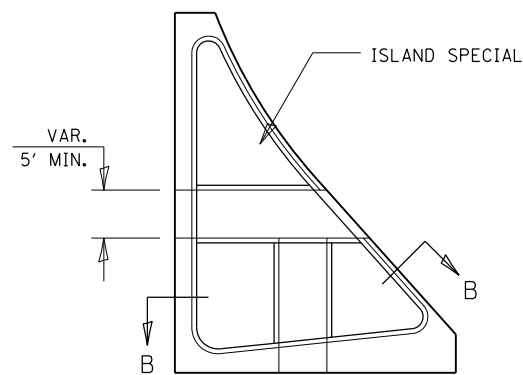

INTERMEDIATE ISLAND
(FOR RIGHT TURN LANE DESIGN)

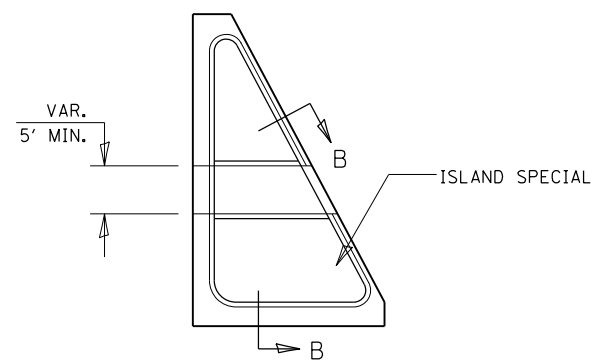

SMALL ISLAND
(FOR TYPICAL DESIGN)

GENERAL NOTES

SEE STANDARDS 606001, 606301, 424031, AND PLAN SHEETS FOR STATION, OFFSETS, RADII, DIMENSIONS, AND DETAILS NOT SHOWN.

THE SIDEWALK SHOULD DRAIN TO THE LOW SIDE OF THE ISLAND. IF NECESSARY THE SIDEWALK SHALL BE SLOPED TO DRAIN AT A MAXIMUM 2% GRADE.

SEE THE PLAN SHEETS FOR THE TYPE OF CURB & GUTTER TO BE USED ON ISLANDS.

THE SIDEWALK SHOULD NOT BE CLOSER THAN 3' FROM THE CORNER OF THE ISLAND.

KEYED LONGITUDINAL CONSTRUCTION JOINTS SHALL BE CONSTRUCTED WITHOUT TIE BARS.

MEDIANS AND LARGE ISLANDS SHALL CONSIST OF PCC SIDEWALK 5", CONCRETE MEDIANS SURFACE 4", CONCRETE CURB, AND COMBINATION CONCRETE CURB & GUTTER, TYPE M OR B OR THE SIZE SPECIFIED. MEDIAN ISLAND CAN ALSO BE SOLID CONCRETE MEDIANS.

LOCATIONS, LAYOUTS, AND WIDTHS OF THE FLUSH SIDEWALK AREA, SHALL BE DETERMINED BY THE DESIGNER AND SHOWN ON THE PLANS.

THE INTERMEDIATE AND SMALL ISLANDS WILL BE MEASURED FOR PAYMENT FROM E.O.P. TO E.O.P. USING EITHER OPTION 1 OR OPTION 2, AS DIRECTED BY THE ENGINEER, AND WILL BE PAID FOR AT THE CONTRACT UNIT PRICE PER SQ. FT. FOR CONCRETE MEDIAN (SPECIAL), WHICH SHALL INCLUDE THE CURB, COMBINATION CURB & GUTTER, SIDEWALK, AGGREGATE FILL, CONCRETE MEDIAN SURFACE, AND SOLID CONCRETE MEDIAN.

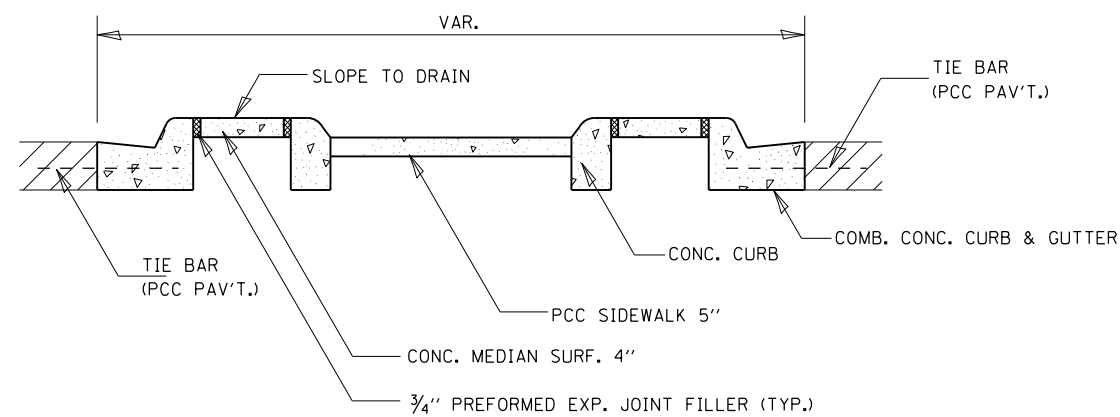

SECTION A-A

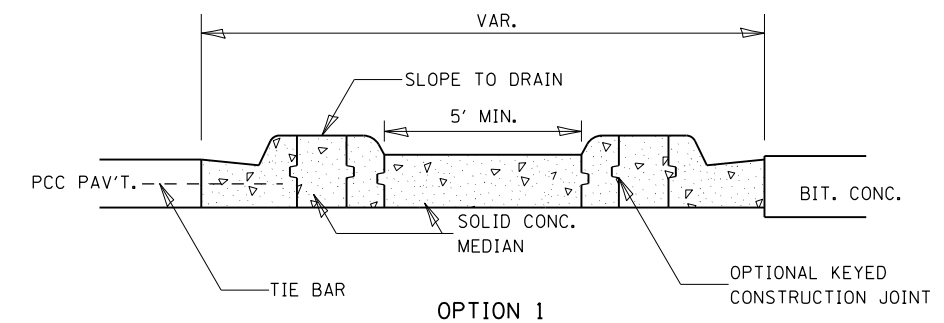

OPTION 1

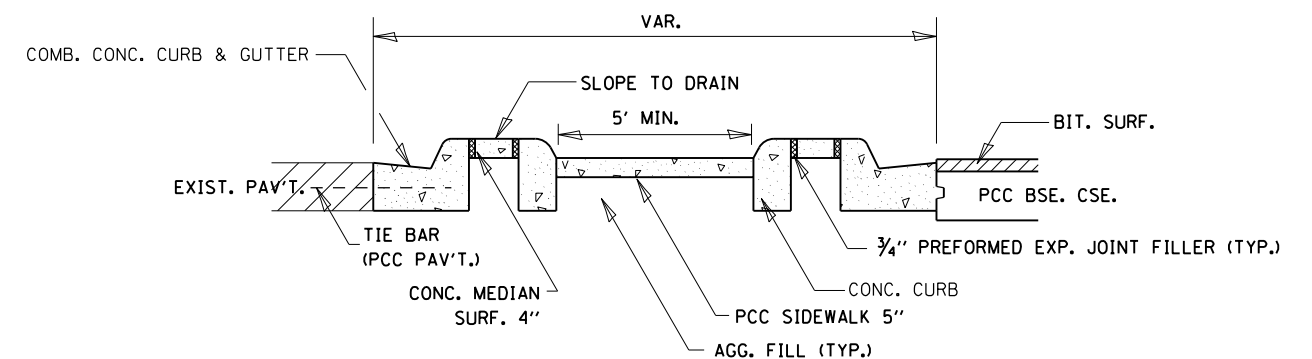

OPTION 2

SECTION B-B

FILE NAME =	USER NAME = budzynskim	DESIGNED -	REVISED -
ca:\pwork\pwork\dot\budzynskim\d0377438\066058-sh-t-details.dgn		DRAWN -	REVISED -
	PLOT SCALE = 100.0000' / 1"	CHECKED -	REVISED -
	PLOT DATE = 6/7/2014	DATE -	REVISED -

STATE OF ILLINOIS
DEPARTMENT OF TRANSPORTATION

PCC ISLANDS AND MEDIANS ACCESSIBLE TO THE DISABLED

SCALE: _____ SHEET NO. ____ OF ____ SHEETS STA. _____ TO STA. _____

F.A.P. RTE.	SECTION	COUNTY	TOTAL SHEETS	SHEET NO.
41	011.11X.11X-3.11X-2/BS-2	KANKAKEE	16	13
CONTRACT NO. 66058			ILLINOIS FED. AID PROJECT	