

**TYPICAL PLACEMENT OF ARROWS  
IN TURN LANES**

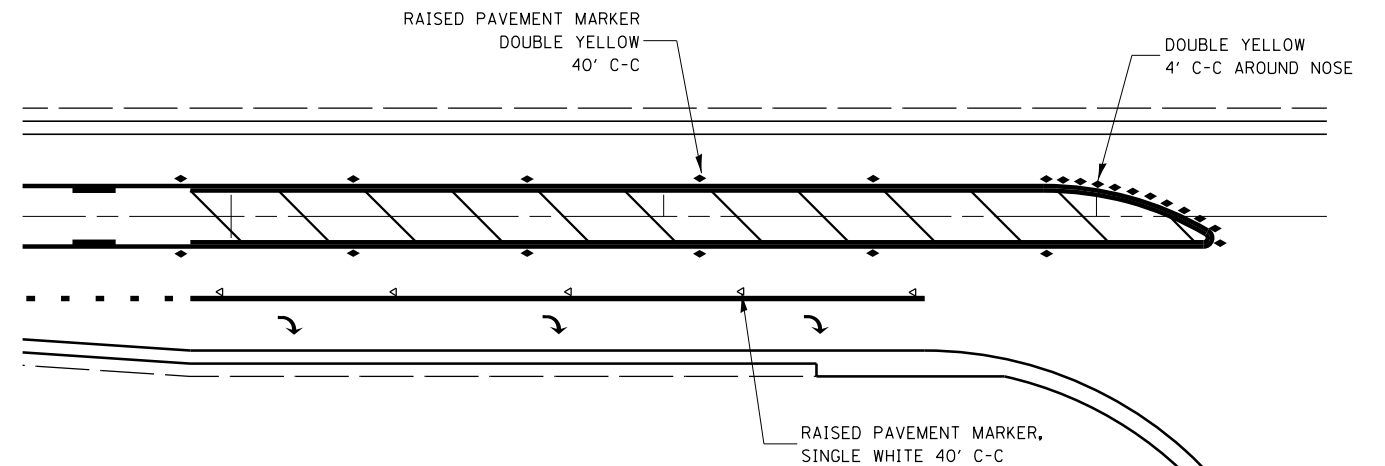

**RAISED REFLECTIVE PAVEMENT MARKERS  
RIGHT TURN LANE**

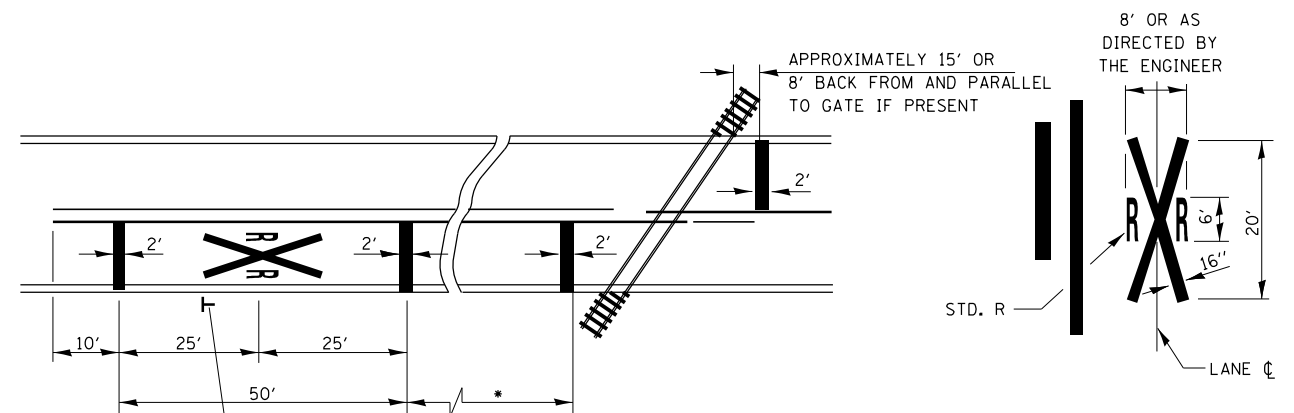

\* MINIMUM DISTANCE  
400' FOR 55 MPH  
250' FOR 45 MPH  
100' FOR 35 MPH OR LESS

NOTES:  
THE TRANSVERSE SPREAD OF THE "X"  
MAY VARY ACCORDING TO LANE WIDTH.

ON MULTI-LANE ROADS, THE STOP LINES  
SHALL EXTEND ACROSS ALL APPROACH  
LANES AND SEPARATE RXR SYMBOLS SHALL  
BE PLACED ADJACENT TO EACH OTHER  
IN EACH LANE.

WHEN THE PAVEMENT MARKING SYMBOL  
IS USED, A PORTION OF THE SYMBOL  
SHOULD BE LOCATED DIRECTLY ADJACENT  
TO THE ADVANCE WARNING SIGN (W10-1).

**PAVEMENT MARKINGS AT  
RAILROAD-HIGHWAY GRADE CROSSING**

FILE NAME =	USER NAME = lukkeridp	DESIGNED -	REVISED -
et:\pw\work\pwidot\lukkeridp\d0380229\0386069-shit-details.dgn		DRAWN -	REVISED -
	PLOT SCALE = 100.0000' / in.	CHECKED -	REVISED -
	PLOT DATE = 6/10/2014	DATE -	REVISED -

**STATE OF ILLINOIS  
DEPARTMENT OF TRANSPORTATION**

<b>DETAILS</b>			
SCALE:	SHEET	OF	SHEETS
		STA.	TO STA.

F.A.P. RTE.	SECTION	COUNTY	TOTAL SHEETS	SHEET NO.
317	(36,21)RS	IROQUOIS	16	12
CONTRACT NO. 66D69			ILLINOIS FED. AID PROJECT	