

T (in.), T <sub>s</sub> (in.)	Reinforcing Steel A <sub>stm</sub> (in. <sup>2</sup> /ft.)										
	2	3	4	5	6	7	8	9	10	11	12
4	0.19	0.15									
5	0.26	0.21	0.18								
6		0.26	0.23	0.22							
7		0.33	0.59	0.27	0.28						
8			0.43	0.39	0.36	0.34	0.40				
9				0.43	0.40	0.37	0.36	0.48			
10				0.47	0.44	0.41	0.38	0.42	0.56		
11				0.54	0.46	0.41	0.41	0.50	0.65		
12				0.58	0.50	0.45	0.45	0.46	0.46	0.75	

(A<sub>stm</sub> reinforcement based upon welded wire fabric conforming to AASHTO M 55 or M 221).

**Notes:**  
 Alternate Section D-D is provided to allow the Contractor the option of casting the bottom slab of the end section first followed by construction of the sidewalls using conventional forming methods. Shop drawings that detail slab thickness and reinforcement layout shall be submitted to the Engineer for review and approval when using Alternate Section D-D.  
 The size and spacing of the v<sub>3</sub>(E) bars shall provide a minimum reinforcement area along each face of the walls (in.<sup>2</sup>/ft.) equal to 1.10\*(A<sub>stm</sub>). v<sub>3</sub>(E) bars may consist of #3 thru #6 size reinforcement bars and the longitudinal spacing shall not exceed the lesser of the wall thickness or 8 inches.  
 Bonded construction joints shall be prepared according to Article 503.09 of the Standard Specifications.

**1 DIMENSION**

- #3 bar = 2'-0"
- #4 bar = 2'-8"
- #5 bar = 3'-4"
- #6 bar = 3'-11"

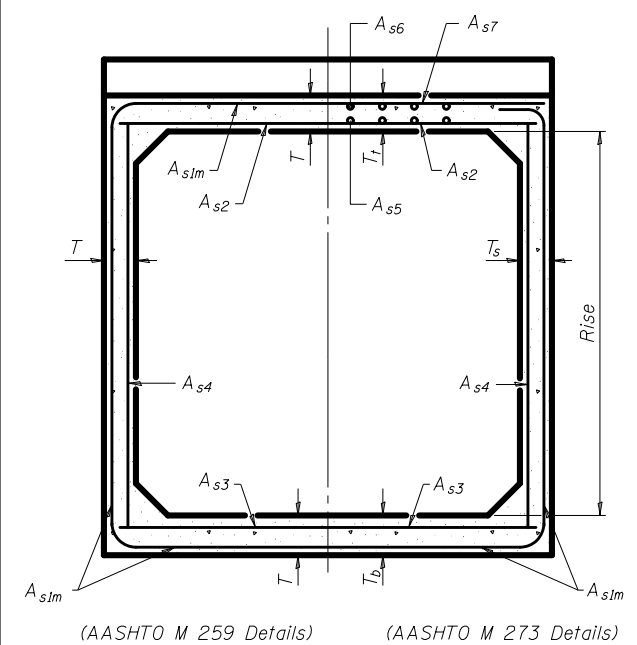

**SECTION C-C**

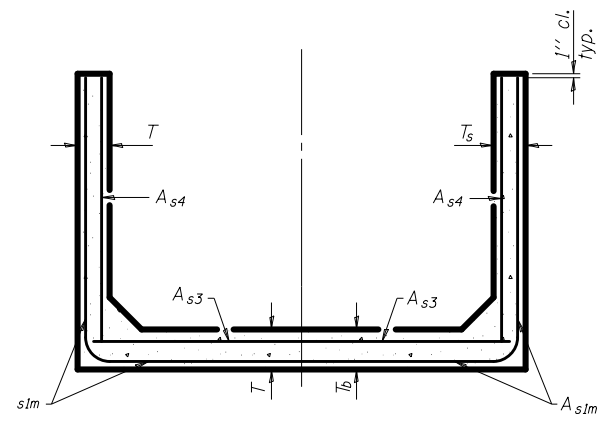

**SECTION D-D**

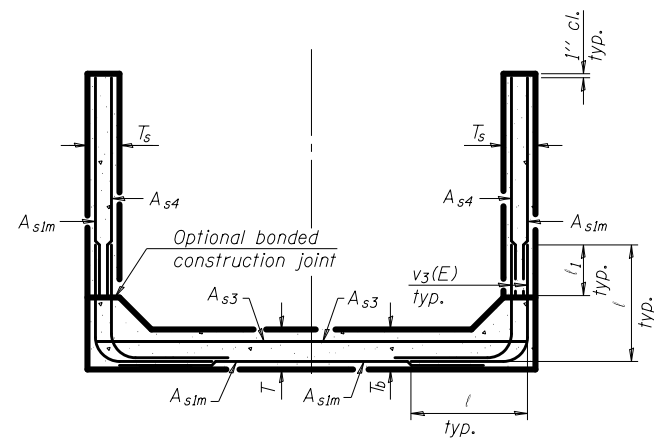

**ALTERNATE SECTION D-D**

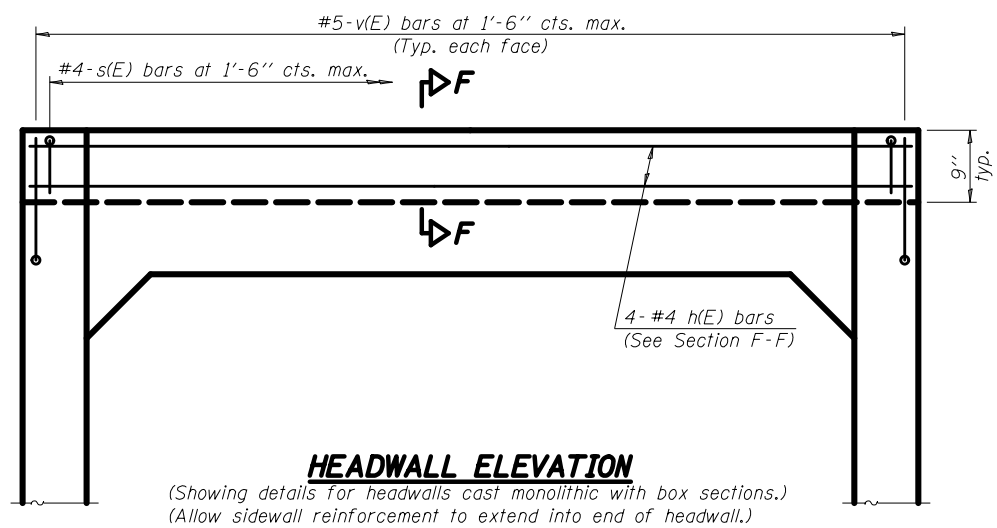

**HEADWALL ELEVATION**

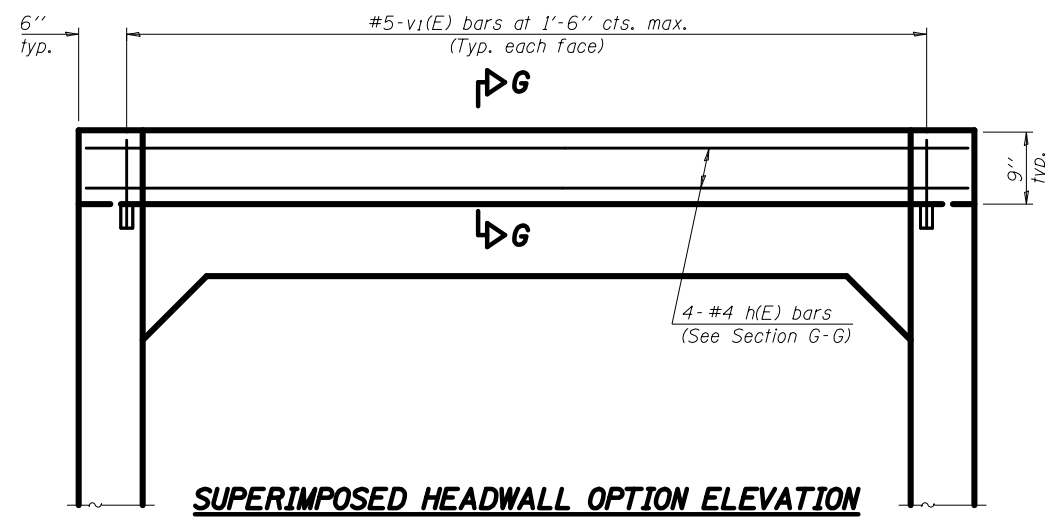

**SUPERIMPOSED HEADWALL OPTION ELEVATION**

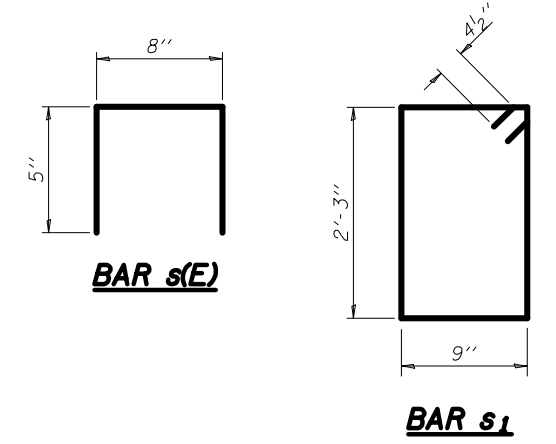

**BAR s(E)**

**BAR s\_1**

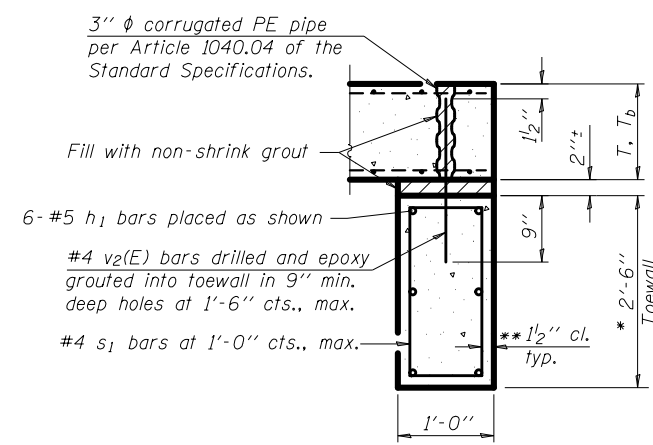

**SECTION E-E**

**TOEWALL CONSTRUCTION SEQUENCE**

- Perform excavation and construct toewall.
1. Backfill accordingly and place bedding for precast box culvert end sections.
  2. Set precast box culvert end sections in place.
  3. Drill and epoxy grout reinforcement in toewall in accordance with Section 584 of the Standard Specifications.
  4. Pressure grout voids using non-shrink grout conforming to Section 1024 of the Standard Specifications.
- \* The Contractor may furnish a precast or cast-in-place toewall. The Contractor shall be responsible for the strength and stability of the precast toewall during handling. Additional lifting points may be required depending upon the length of the toewall or the Contractor may need to modify the design of the toewall for the proposed handling method.
- \*\* If soil conditions permit, the sides of the toewall may be poured directly against the soil. The clear cover on the sides of the toewall shall be increased to 3" by increasing the thickness of the toewall.

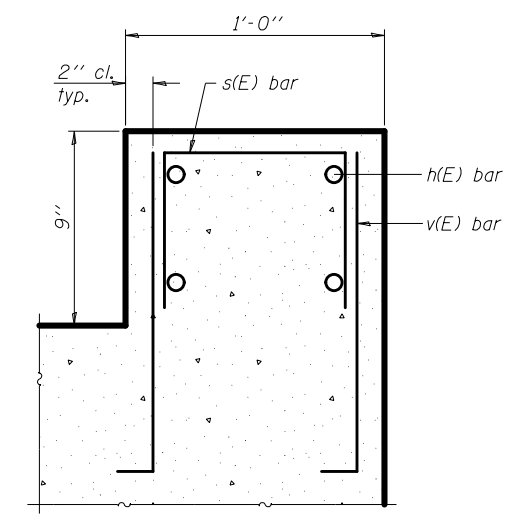

**SECTION F-F**

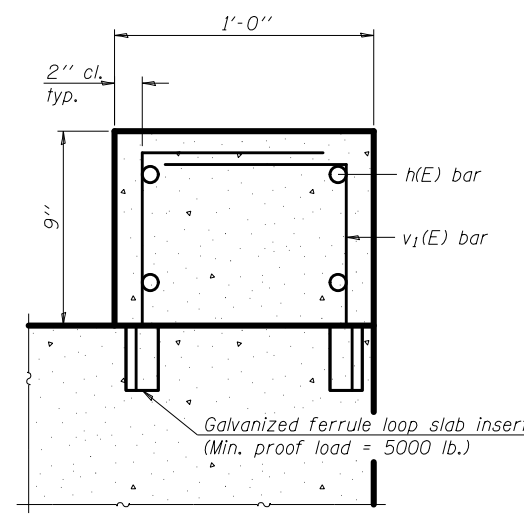

**SECTION G-G**

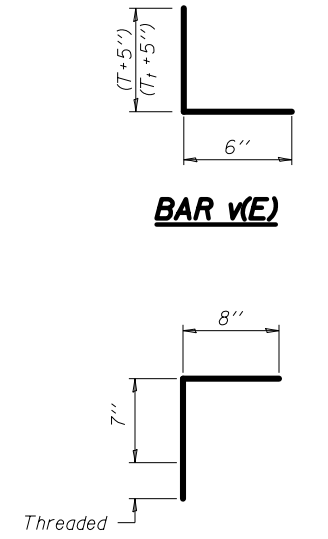

**BAR v(E)**

**BAR v\_1(E)**

(Sheet 2 of 2)

DESIGNED -	EXAMINED	DATE	STATE OF ILLINOIS DEPARTMENT OF TRANSPORTATION	BOX CULVERT END SECTION DETAILS	F.A.U. RTE.	SECTION	COUNTY	TOTAL SHEETS	SHEET NO.	
CHECKED -	PASSED				9128	28-R-1	MADISON	64	51	
DRAWN -					CONTRACT NO. 76F11					
CHECKED -					ILLINOIS FED. AID PROJECT					