

# DETAIL FOR BUTT JOINTS

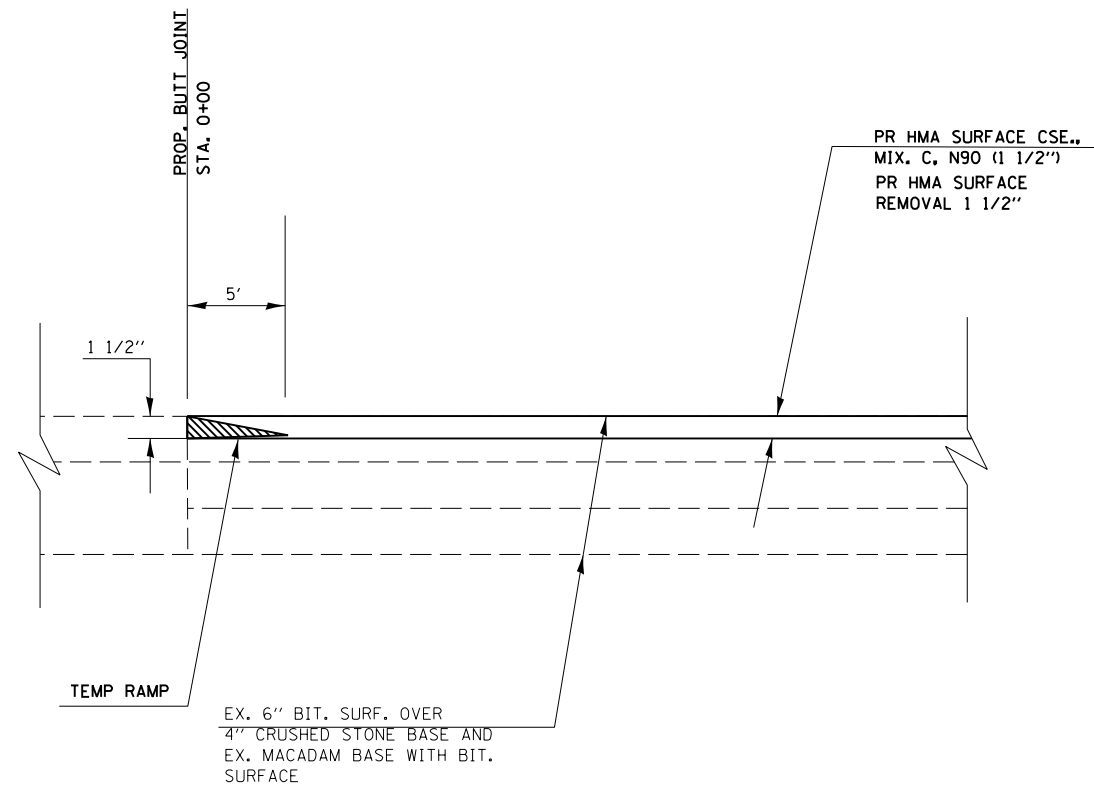

TO BE USED:  
STA. 0+00 (BEGINNING OF PROJECT)

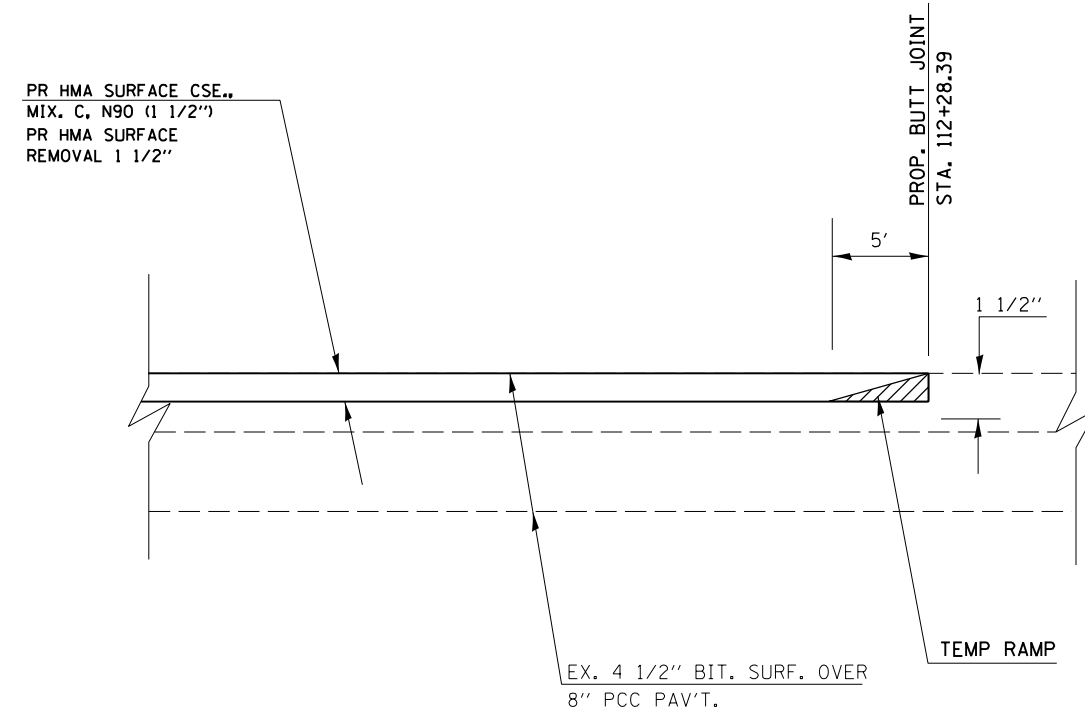

TO BE USED:  
STA. 112+28.39 (END OF PROJECT)

FILE NAME =	USER NAME = mccordkr	DESIGNED -	REVISED -	<b>STATE OF ILLINOIS DEPARTMENT OF TRANSPORTATION</b>	<b>DETAIL: BUTT JOINT BEGINNING AND ENDING STATION</b>	F.A.P. RTE.	SECTION	COUNTY	TOTAL SHEETS	SHEET NO.
et:\pw\work\p1dot\mccordkr\0181440\78196-shfts.dgn		DRAWN -	REVISED -			780	(6,6-1)RS-2	HARDIN	15	13
PLOT SCALE = 200.0000' / in.		CHECKED -	REVISED -			CONTRACT NO. 78196				
PLOT DATE = 6/5/2014		DATE -	REVISED -			ILLINOIS FED. AID PROJECT				
						SCALE:	SHEET NO.	OF SHEETS	STA.	TO STA.