

**UN053**

REVISIONS		
NUMBER	BY	DATE

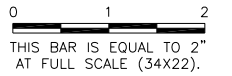

**LEGEND**

- DRAINAGE CONDUIT MATERIAL-CONCRETE
- MIDDLE BEDDING LOOSELY PLACED UNCOMPACTED BEDDING
- HAUNCH AND OUTER BEDDING COMPACTION- 95% STANDARD PROCTOR
- LOWER SIDE AND OVERFILL COMPACTION- SAME AS EMBANKMENT REQUIREMENTS
- $D_o$  PIPE OUTSIDE DIAMETER
- $D_i$  PIPE INSIDE DIAMETER

**NOTES**

- BEDDING SHOWN IS IN ACCORDANCE WITH "STANDARD EMBANKMENT INSTALLATIONS", STANDARD INSTALLATION & BEDDING FACTORS FOR THE INDIRECT DESIGN METHOD (DESIGN DATA 40), AMERICAN CONCRETE PIPE ASSOCIATION.
- BACKFILL TO EXTEND 3' BEYOND EDGES OF PROPOSED PAVEMENT.

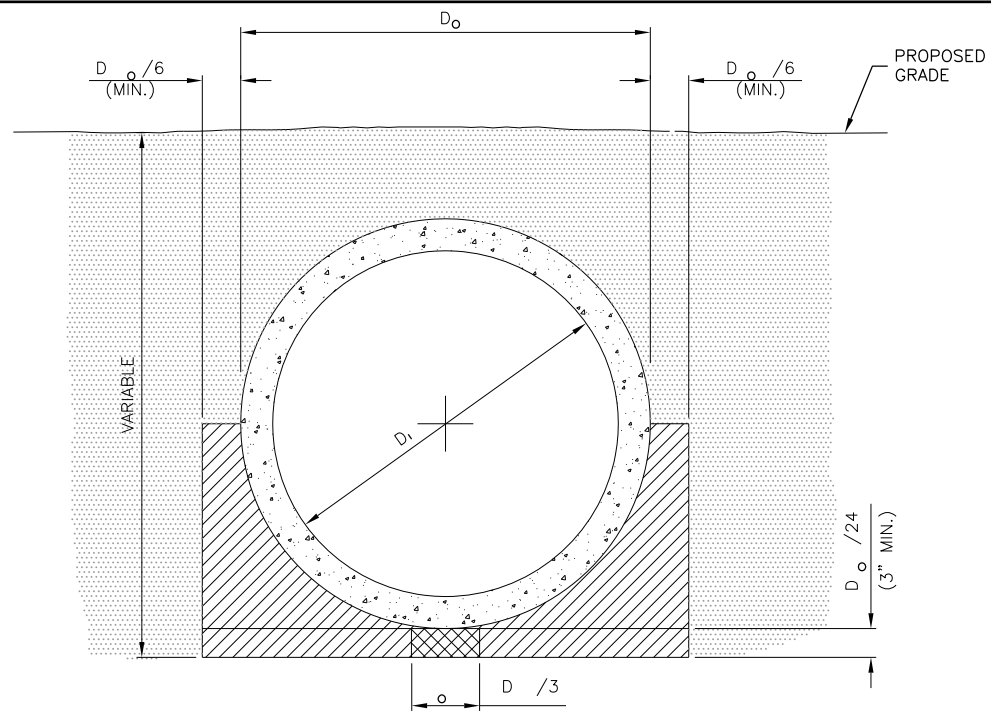

**STANDARD TRENCH INSTALLATION  
NON-PAVED AREA**

N.T.S.

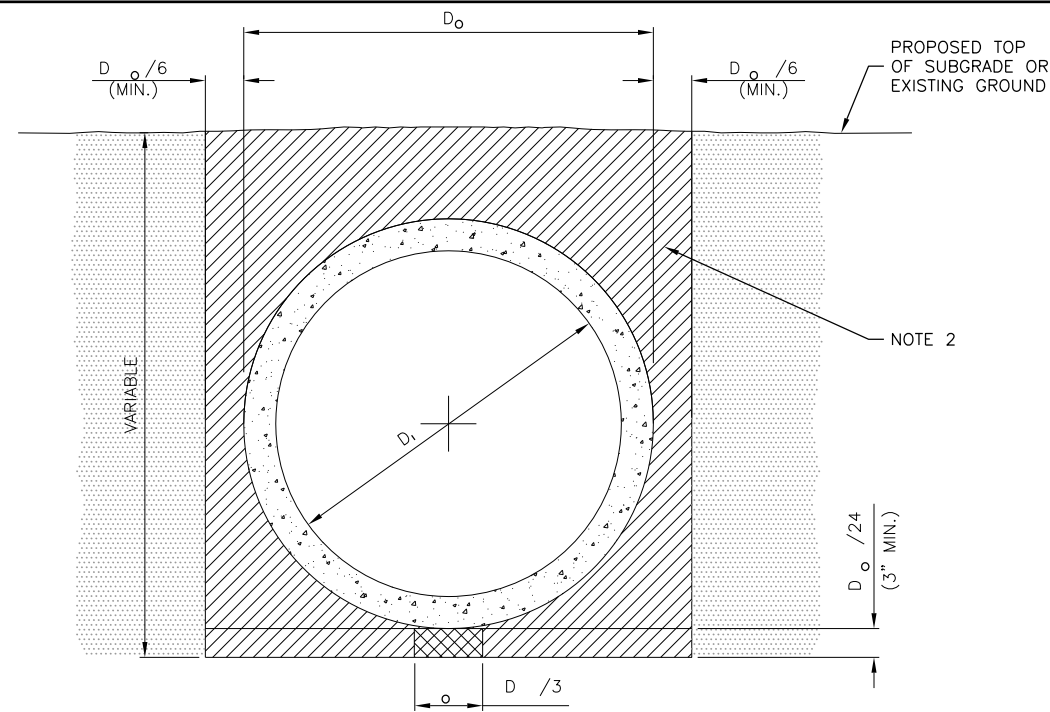

**STANDARD TRENCH INSTALLATION  
PROPOSED PAVED AREA**

N.T.S.

PIPE DIA.	APPROX WT. (lbs.)	WALL	A	B	C	D	E	G	R	SLOPE
12"	530	2"	4"	2'-0"	4'-0 7/8"	6'-0 7/8"	2'-0"	2"	9"	3:1
15"	740	2 1/4"	6"	2'-3"	3'-10"	6'-1"	2'-6"	2 1/4"	11"	3:1
18"	990	2 1/2"	9"	2'-3"	3'-10"	6'-1"	3'-0"	2 1/2"	12"	3:1
21"	1280	2 3/4"	9"	2'-11"	3'-2"	6'-1"	3'-6"	2 3/4"	13"	3:1
24"	1520	3"	9 1/2"	3'-7 1/2"	2'-6"	6'-1 1/2"	4'-0"	3"	14"	3:1
27"	1930	3 1/4"	10 1/2"	4'-0"	2'-1 1/2"	6'-1 1/2"	4'-6"	3 1/4"	14 1/2"	3:1
30"	2190	3 1/2"	1'-0"	4'-6"	1'-7 3/4"	6'-1 3/4"	5'-0"	3 1/2"	15"	3:1
33"	3200	3 3/4"	1-1 1/2"	4'-10 1/2"	3'-3 1/4"	8'-1 3/4"	5'-6"	3 3/4"	17 1/2"	3:1
36"	4100	4"	1'-3"	5'-3"	2'-10 3/4"	8'-1 3/4"	6'-0"	4"	20"	3:1
42"	5380	4 1/2"	1'-9"	5'-3"	2'-11"	8'-2"	6'-6"	4 1/2"	22"	3:1
48"	6550	5"	2'-0"	6'-0"	2'-2"	8'-2"	7'-0"	5"	22"	3:1
54"	8240	5 1/2"	2'-3"	5'-5"	2'-11"	8'-4"	7'-6"	5 1/2"	24"	2.4:1
60"	8730	6"	2'-11"	5'-0"	3'-3"	8'-3"	8'-0"	5"	*	2:1
66"	10710	6 1/2"	2'-6"	6'-0"	2'-3"	8'-3"	8'-6"	5 1/2"	*	2:1
72"	12520	7"	3'-0"	6'-6"	1'-9"	8'-3"	9'-0"	6"	*	1.86:1
78"	14770	7 1/2"	3'-0"	7'-6"	1'-9"	9'-3"	9'-6"	6 1/2"	*	1.82:1
84"	18160	8"	3'-0"	7'-6 1/2"	1'-9"	9'-3 1/2"	10'-0"	6 1/2"	*	1.5:1

\* RADIUS AS FURNISHED BY MANUFACTURER.

**NOTES**

- PRECAST CONCRETE FLARED END SECTIONS SHALL CONFORM TO THE APPLICABLE REQUIREMENTS OF AASHTO M-170 CLASS III, WALL B REINFORCED CONCRETE PIPE.
- PRECAST CONCRETE FLARED END SECTION FOR PIPE DIAMETER REQUIRED SHALL BE AS INDICATED ON DETAIL PLAN FOR EACH INDIVIDUAL INSTALLATION.
- THE END BLOCK SHALL BE PLACED PRIOR TO THE INSTALLATION OF THE FLARED END SECTION. THE END BLOCK SHALL BE BACKFILLED IN ACCORDANCE WITH ITEM 701.

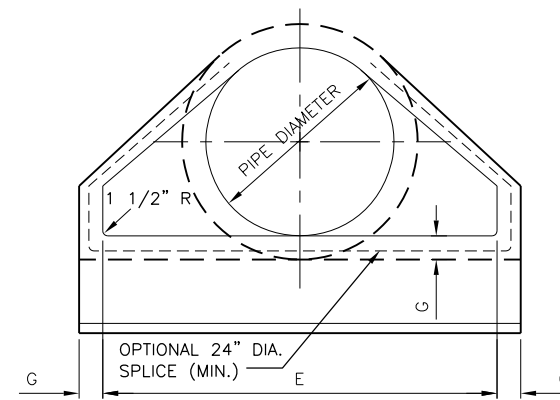

**END VIEW**

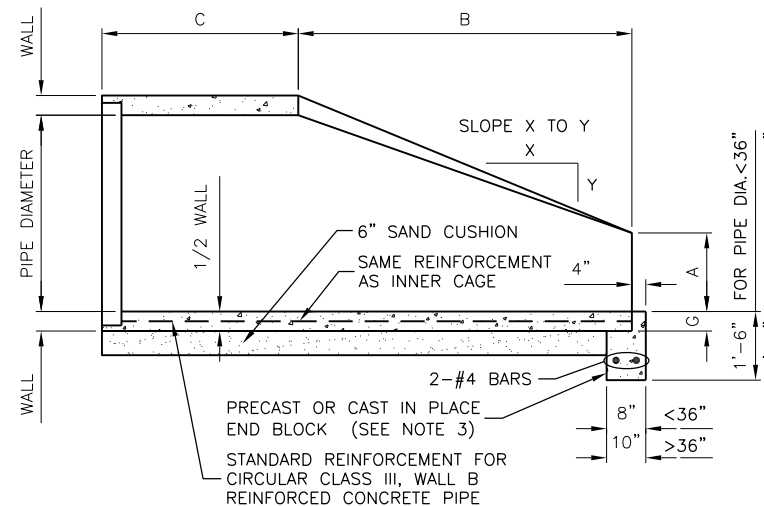

**LONGITUDINAL SECTION**

**PRECAST REINFORCED CONCRETE FLARED END SECTION**

(I.D.O.T. STD. NO. 542301)

N.T.S.

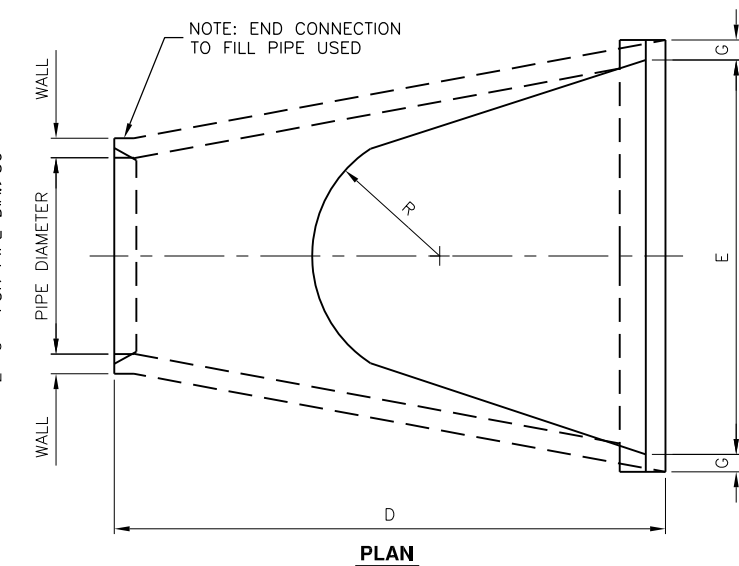

**PLAN**

UNIVERSITY OF ILLINOIS  
 WILLARD AIRPORT  
 SAVOY, ILLINOIS

BASE BID - REALIGN AND WIDEN TAXIWAY C  
 DRAINAGE DETAILS 1

© Copyright CMT, Inc.

**CMT**  
 CRAWFORD, MURPHY & TILLY, INC.  
 CONSULTING ENGINEERS  
 License No. 184-000613



DESIGN BY:	CBG
DRAWN BY:	ADD
CHECKED BY:	CET
APPROVED BY:	CET
DATE:	JUNE 27, 2014
JOB No:	13059-02-00

IL PROJ. NO. CMI-4347  
 AIP PROJ. NO. 3-17-0016-XX