

**ELECTRICAL SERVICE – PANEL DIAGRAM (TYPICAL FOR POLE AND GROUND MOUNTED SERVICE)**  
**SERVICE INSTALLATION POLE MOUNT (SHOWN)**  
 (NOT TO SCALE)

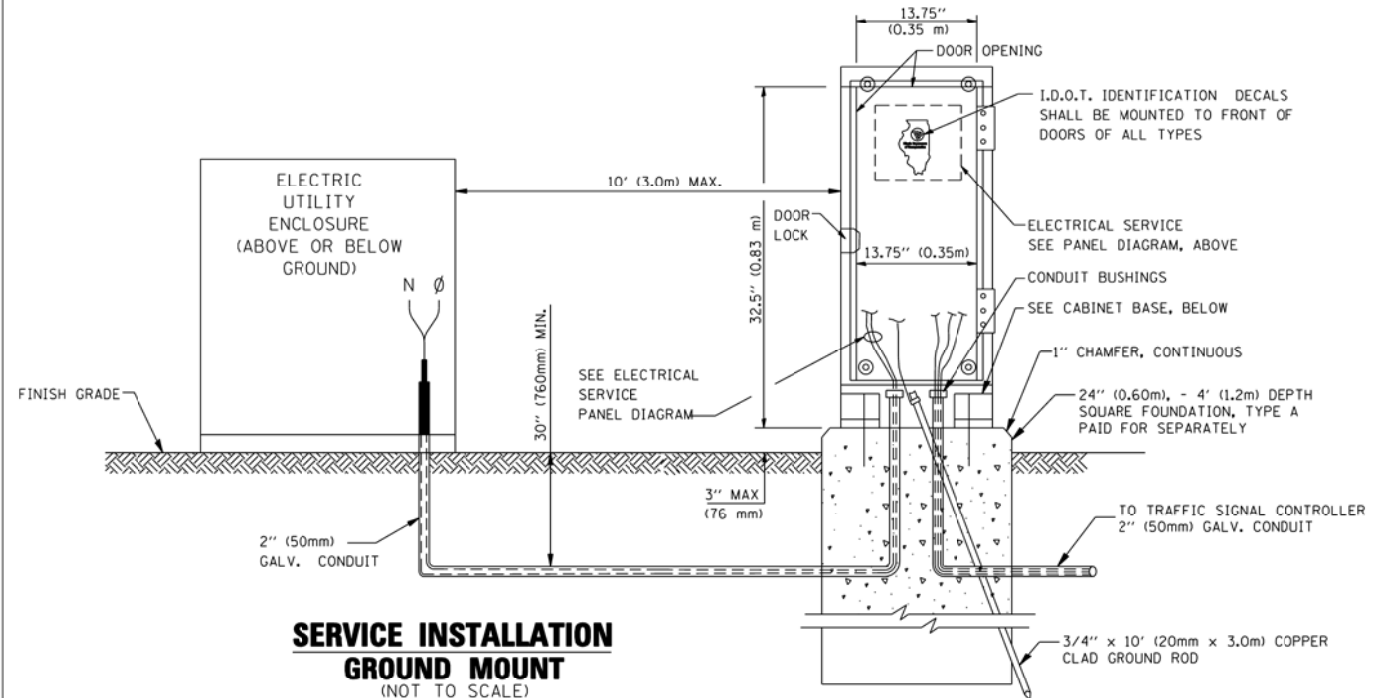

**SERVICE INSTALLATION GROUND MOUNT**  
 (NOT TO SCALE)

**CABINET – BASE BOLT PATTERN**  
 (NOT TO SCALE)

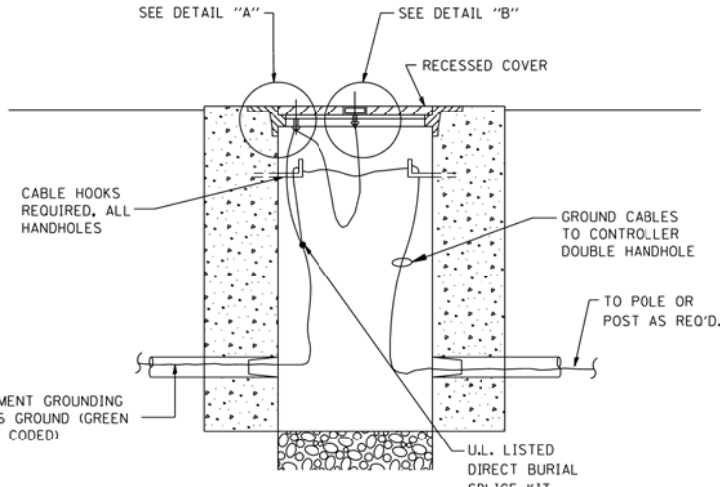
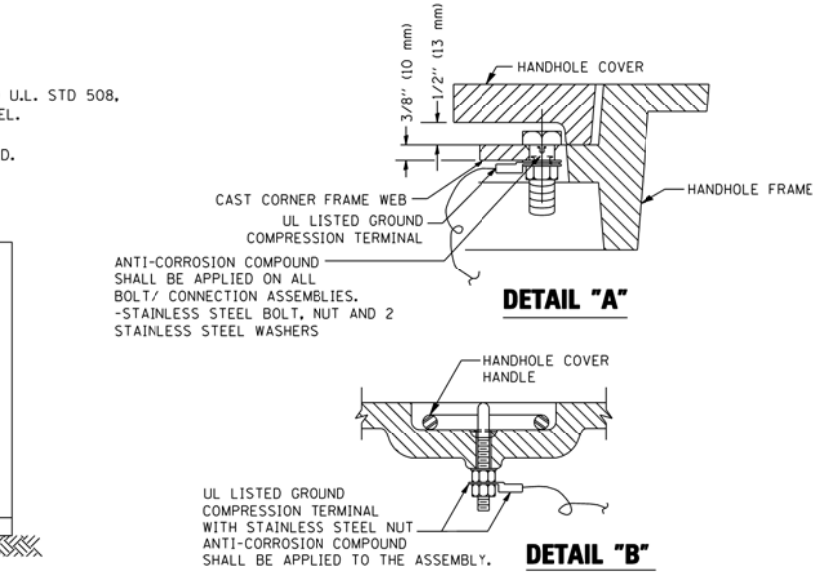
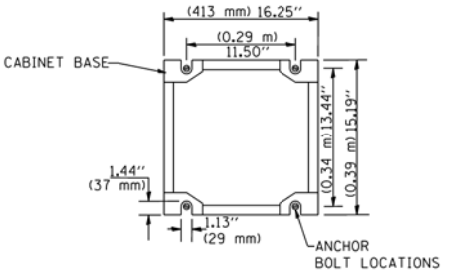

**HANDHOLE COVER & FRAME – GROUNDING DETAIL**  
 (NOT TO SCALE)

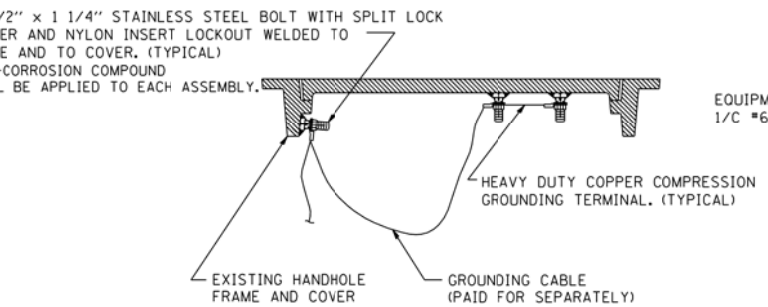

**EXISTING HANDHOLE COVER & FRAME – GROUNDING DETAIL**  
 (NOT TO SCALE)

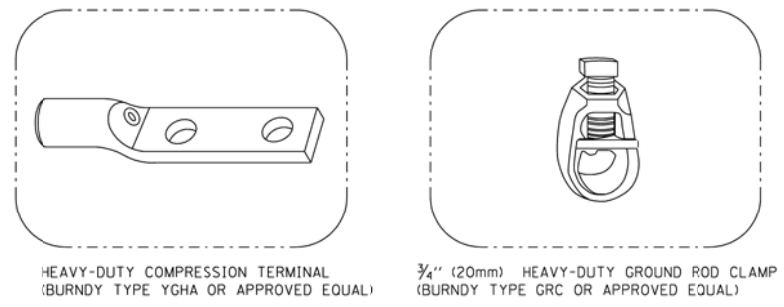

HEAVY-DUTY COMPRESSION TERMINAL (BURNDY TYPE YGHA OR APPROVED EQUAL)  
 3/4" (20mm) HEAVY-DUTY GROUND ROD CLAMP (BURNDY TYPE GRC OR APPROVED EQUAL)

- NOTES:**
- ALL CLAMPS SHALL BE BRONZE OR COPPER, U.L. APPROVED.
  - GROUND CABLE SHALL BE LOOPED OVER HOOKS IN THE HANDHOLES
  - 6.5' (2.0m) SLACK SHALL BE PROVIDED IN SINGLE HANDHOLES
  - 13' (4.0m) OF SLACK SHALL BE PROVIDED IN DOUBLE HANDHOLES.
  - 5' (1.4m) OF SLACK SHALL BE PROVIDED BETWEEN FRAME AND COVER.

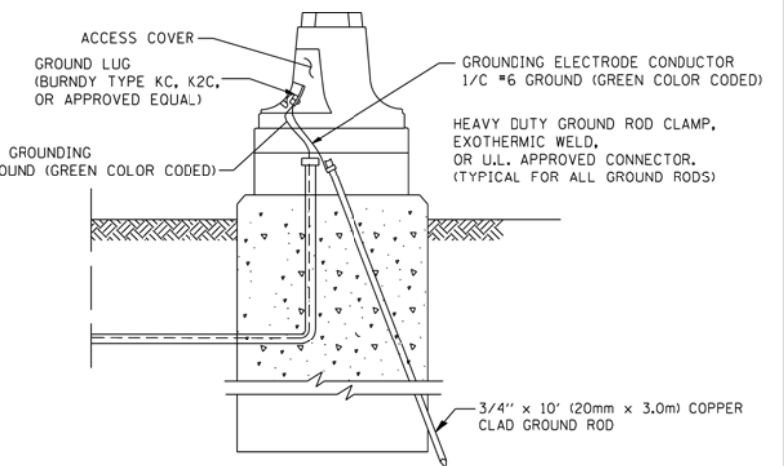

**MAST ARM POLE / POST-GROUNDING DETAIL**  
 (NOT TO SCALE)

|   |                             |                 |           |
|---|-----------------------------|-----------------|-----------|
| FILE NAME =                             | USER NAME = kanthapixaybc   | DESIGNED - DAD  | REVISED - |
| ci:\pw\work\PIWIDT\KANTHAPIXAYBC\d01126 | 4\tr\of\ic\legend.v7.dgn    | DRAWN - BCK     | REVISED - |
|   | PLOT SCALE = 20.0000' / IN. | CHECKED - DAD   | REVISED - |
|   | PLOT DATE = 10/6/2009       | DATE - 10/28/09 | REVISED - |

**STATE OF ILLINOIS**  
**DEPARTMENT OF TRANSPORTATION**

DISTRICT 1  
 STANDARD TRAFFIC SIGNAL DESIGN DETAILS

|                     |            |                  |              |           |
|---------------------|------------|------------------|--------------|-----------|
| F.A. RTE.           | SECTION    | COUNTY           | TOTAL SHEETS | SHEET NO. |
| VAR                 | 2013-005-1 | COOK             | 85           | 10        |
| CONTRACT NO. 60W23  |            |                  |              |           |
| FED. ROAD DIST. NO. | ILLINOIS   | FED. AID PROJECT |              |           |

SCALE: SHEET NO. 3 OF 6 SHEETS STA. TO STA.