

**REMOVAL PLAN**  
Existing north end section of 6' x 6' reinforced concrete box culvert - Sta 870+00.00

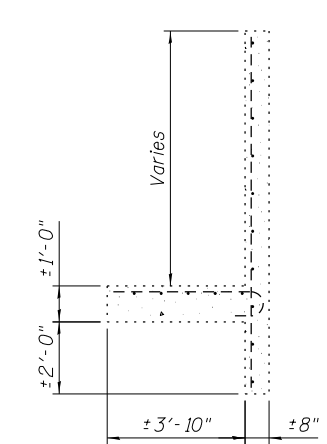

**SECTION A-A**  
Existing reinforced concrete wingwall to be removed

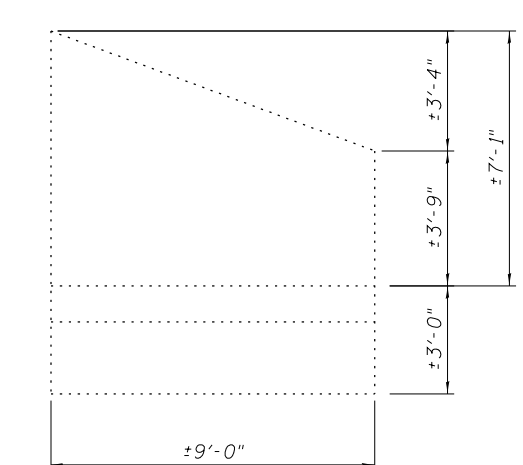

**ELEVATION**  
Existing reinforced concrete wingwall to be removed

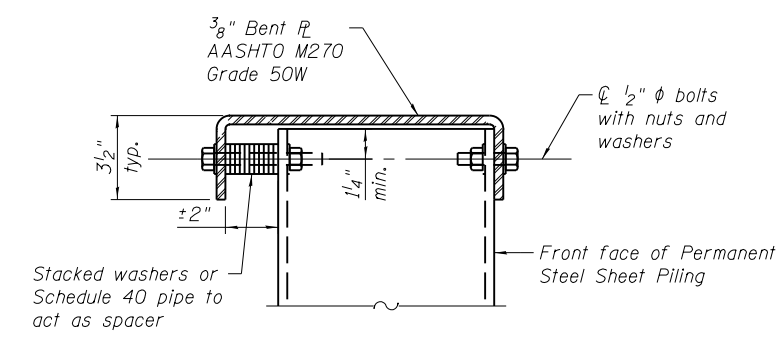

**SECTION C-C**  
Fabricated steel cap

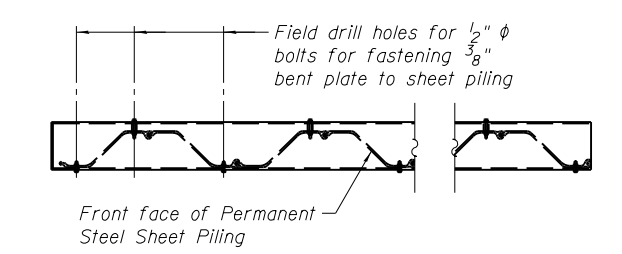

**WINGWALL PLAN**  
Showing connection of fabricated steel cap to Permanent Steel Sheet Piling

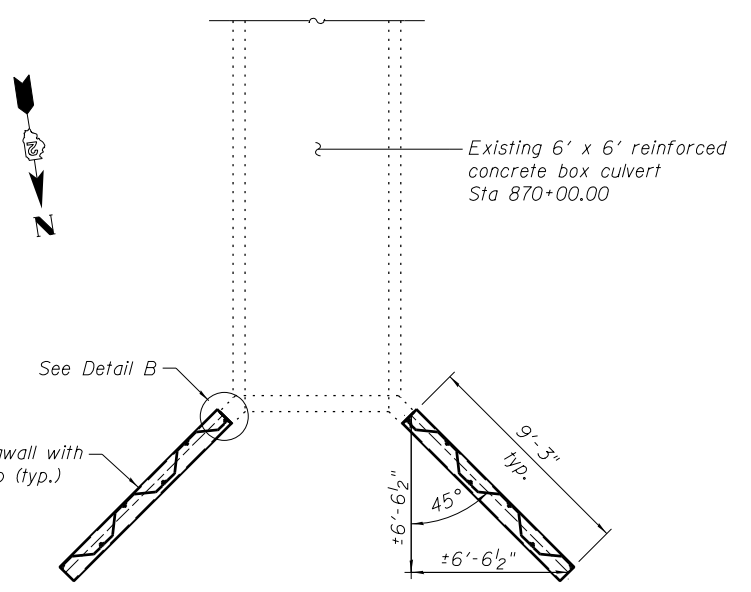

**PLAN**  
Showing new sheet pile wingwalls

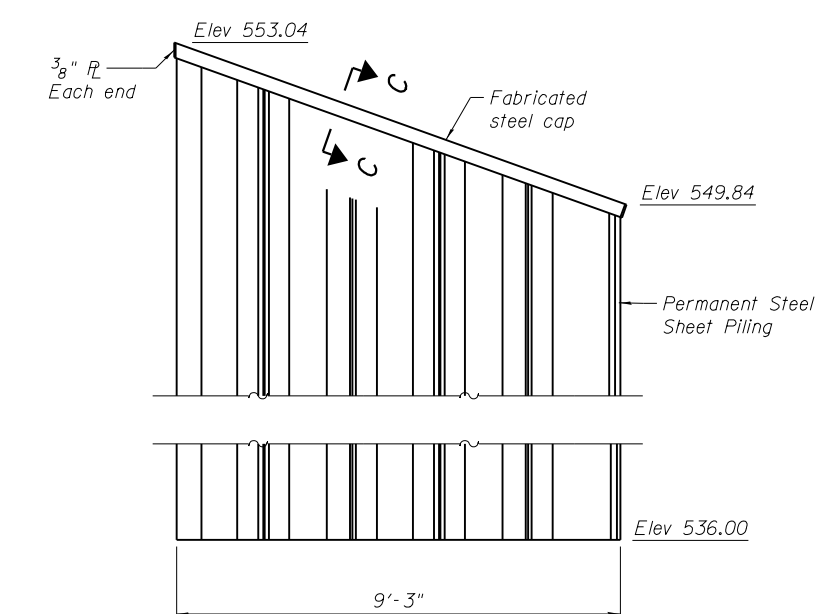

**WINGWALL ELEVATION**

The sheet piling for the wingwalls shall conform to the special provision Permanent Steel Sheet Piling. The minimum effective section modulus for the Permanent Steel Sheet Piling shall be 3.9 in<sup>3</sup>/ft.

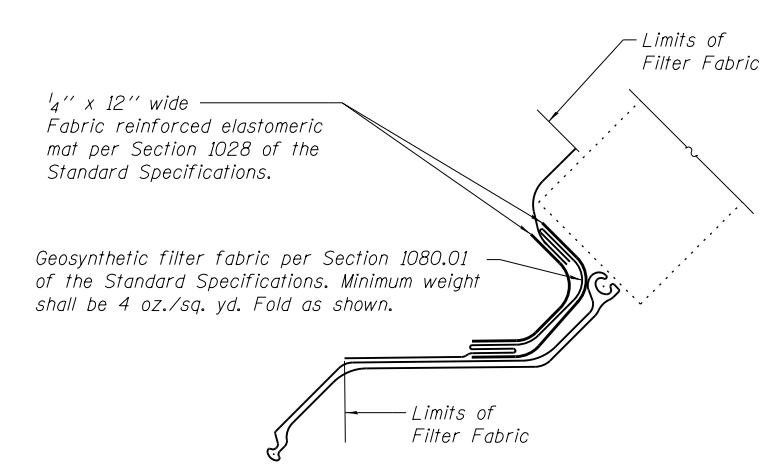

**DETAIL B**

Note: Fabric reinforced elastomeric mat and geosynthetic filter fabric shall not be paid for separately but shall be included in the cost of Permanent Steel Sheet Piling.

FILE NAME = W:\Projects\2010\100120 PTB 157\25\cadd\Structural\Drawings\3. IL 92 Culverts\Station870+00.00\Final\_Submittal\_13.0320\870+00.00-64H1-005-SheetP1.dwg

**WILLS BURKE KELSEY ASSOCIATES LTD.**  
116 West Main Street, Suite 201  
St. Charles, Illinois 60174

USER NAME = hferstl	DESIGNED - AWH	REVISED -
PLOT SCALE =	CHECKED - AEU	REVISED -
PLOT DATE = 3/20/2013	DRAWN - AWH	REVISED -
	CHECKED - AEU	REVISED -

**STATE OF ILLINOIS**  
**DEPARTMENT OF TRANSPORTATION**

**BOX CULVERT END SECTION DETAILS - STA. 870 + 00.00 LT.**  
**STRUCTURE NO. 081-1053**

SHEET NO. 5 OF 6 SHEETS

F.A.P. RTE.	SECTION	COUNTY	TOTAL SHEETS	SHEET NO.
599	(83MFT & 103MFT)W	ROCK ISLAND	340	163
CONTRACT NO. 64H11				
FED. ROAD DIST. NO.		ILLINOIS FED. AID PROJECT		