

STA. 91+00.00 - 95+80.00 - FULL SE = 2.80%
 STA. 95+80.00 - 96+20.57 - FULL SE = 2.80% - STRUCTURE REMOVAL/EMBANKMENT AREA
 STA. 96+20.57 - 96+50.57 - BRIDGE APPROACH PAVEMENTS (SPECIAL) - FULL SE = 2.80%
 STA. 96+50.57 - 102+35.46 - BRIDGES (SEE STRUCTURE DETAILS)
 * STA. 102+35.46 - 102+65.46 - BRIDGE APPROACH PAVEMENTS (SPECIAL) - FULL SE = 2.80%
 * STA. 102+65.46 - 103+10.00 - FULL SE = 2.80% - STRUCTURE REMOVAL/EMBANKMENT AREA
 * STA. 103+10.00 - 104+54.36 - FULL SE = 2.80%
 STA. 104+54.36 - 106+56.05 - SE TRANSITION

LEGEND FOR FAU 7706 (BL-55) TYPICAL SECTIONS

- A EXISTING PCC PAVEMENT, 10"
- B EXISTING PCC BASE COURSE, 10"
- C EXISTING AGGREGATE BASE COURSE, 9"
- D EXISTING HMA SHOULDERS, 8"
- E EXISTING COMBINATION CONCRETE CURB AND GUTTER, TYPE B-6.24
- F EXISTING HMA SURFACE, 3"±
- G EXISTING HMA SURFACE, 6"±
- H EXISTING CONCRETE BARRIER W/ GLARE SCREEN
- I PROPOSED SUBBASE GRANULAR MATERIAL, TYPE A 8"
- J PROPOSED HMA SURFACE REMOVAL, 3"
- K PROPOSED HMA BASE COURSE / WIDENING, 10 3/4"
- L PROPOSED HMA SHOULDERS, 8"
- M PROPOSED HMA SHOULDERS, 13.5"
- N PROPOSED HMA SHOULDERS, VAR. DEPTH
- O PROPOSED COMBINATION CONCRETE CURB AND GUTTER, TYPE B-6.24
- P PROPOSED HMA CONCRETE BINDER COURSE, IL 19.0, N70, VAR. DEPTH (2 1/4" MIN.)
- Q PROPOSED LEVELING BINDER (MACHINE METHOD), N70, VAR. DEPTH (1" MINIMUM)
- R PROPOSED HMA CONCRETE SURFACE COURSE, MIX D, N70, 1.5"
- S PROPOSED AGGREGATE SHOULDERS, TYPE B, 4"
- T PROPOSED TOP SOIL PLACEMENT 4"
- U PROPOSED PAVEMENT MARKING, LINE 5"
- V PROPOSED SUB-BASE GRANULAR MATERIAL, TYPE C VAR. DEPTH
- W PROPOSED PIPE UNDERDRAINS 4"
- X PROPOSED PIPE UNDERDRAINS 4" (SPECIAL)

SECTION E-E

PR GUARDRAIL SECTION
 STA. 94+25.00 - 96+21.06 LT
 STA. 96+21.06 - 96+51.09 LT - BR. APPR. PVT. (SPL.)

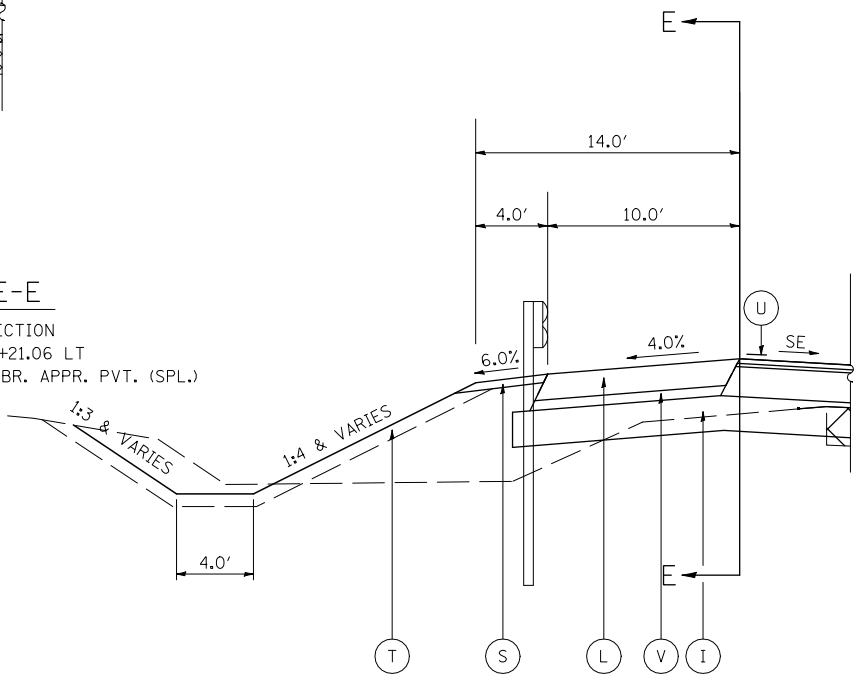

SECTION E-E

PR GUARDRAIL SECTION
 NO EXISTING CURB & GUTTER
 STA. 102+64.98 - 106+50.00, LT.

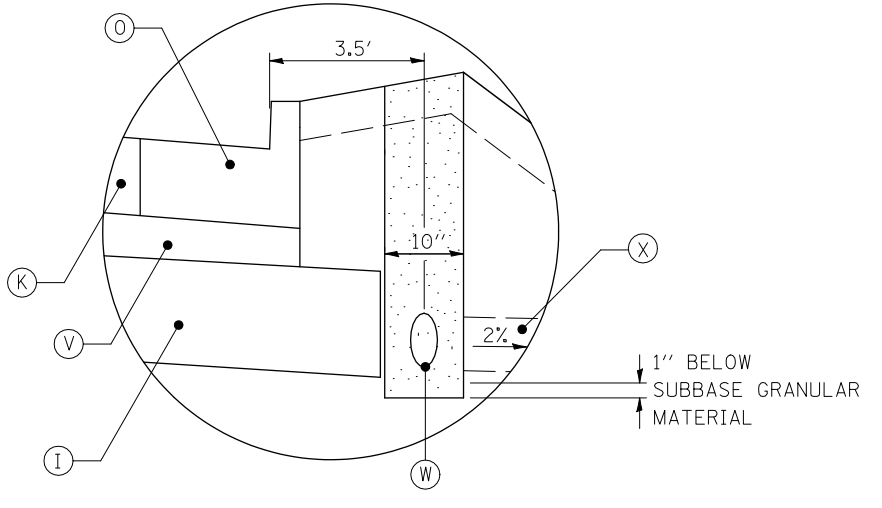

PIPE UNDERDRAIN DETAIL

STA 80+00.00 - 90+31.37 LT
 STA 80+00.00 - 96+20.00 RT
 STA 102+66.00 - 106+56.00 RT

LAST SAVED = 5/23/2013 10:39:32 AM
 PEN TABLE = 10:39:32 AM
 PLOT DRIVER = TR-18pdf-Block-Half.plt

FILE NAME =	USER NAME = jepettibone	DESIGNED -	REVISED -
1:\06103\cad\1\plans\004.D672789-Sht-Typical.dgn		DRAWN -	REVISED -
PLOT SCALE = 20.0000' / IN.		CHECKED -	REVISED -
PLOT DATE = 5/23/2013 10:39:32 AM		DATE -	REVISED -

**STATE OF ILLINOIS
DEPARTMENT OF TRANSPORTATION**

TYPICAL SECTIONS

SCALE: NONE SHEET NO. 4 OF 10 SHEETS STA. TO STA.

F.A.U. RTE.	SECTION	COUNTY	TOTAL SHEETS	SHEET NO.
7706	23(B-1)	LOGAN	179	17
BUS. LOOP 55 OVER SALT CREEK			CONTRACT NO. 72789	
FED. ROAD DIST. NO. ILLINOIS FED. AID PROJECT				