

STATE OF ILLINOIS
DEPARTMENT OF TRANSPORTATION

ROUTE NO.	SECTION	COUNTY	TOTAL SHEETS	SHEET NO.
F.A.I. 94	2006-043 RS	COOK	135	112
FED. ROAD DIST. NO. 7	ILLINOIS	FED. AID PROJECT		

Contract # 62747

DIMENSION TABLE

Girder	N. Abut.		S. Abut.			
	"A" (in)	bars required	"A" (in)	bars required		
1	8 1/8	3- #5 u(E)	n(E)	5 3/4	3- #5 u(E)	n(E)
2	8 1/8	3- #5 u(E)	n(E)	5 3/4	3- #5 u(E)	n(E)
3	8 1/8	3- #5 u(E)	n(E)	5 3/4	3- #5 u(E)	n(E)
4	8 1/8	3- #5 u(E)	n(E)	5 3/4	3- #5 u(E)	n(E)
5	8 1/8	3- #5 u(E)	n(E)	5 3/4	3- #5 u(E)	n(E)
6	8 1/8	3- #5 u(E)	n(E)	5 3/4	3- #5 u(E)	n(E)
7	8 1/8	3- #5 u(E)	n(E)	5 3/4	3- #5 u(E)	n(E)
8	8 1/8	3- #5 u(E)	n(E)	5 3/4	3- #5 u(E)	n(E)
9	8 1/8	3- #5 u(E)	n(E)	5 3/4	3- #5 u(E)	n(E)
10	8 1/8	3- #5 u(E)	n(E)	5 3/4	3- #5 u(E)	n(E)
11	8 1/8	3- #5 u(E)	n(E)	5 3/4	3- #5 u(E)	n(E)
12	8 1/8	3- #5 u(E)	n(E)	6 3/4	3- #5 u(E)	n(E)
13	8 1/8	3- #5 u(E)	n(E)	6 3/4	3- #5 u(E)	n(E)
14	8 1/8	3- #5 u(E)	n(E)	6 3/4	3- #5 u(E)	n(E)
15	8 1/8	3- #5 u(E)	n(E)	6 3/4	3- #5 u(E)	n(E)
16	8 1/8	3- #5 u(E)	n(E)	5 3/4	3- #5 u(E)	n(E)
17	8 1/8	3- #5 u(E)	n(E)	5 3/4	3- #5 u(E)	n(E)
18	9 1/8	3- #5 u(E)	n(E)	5 3/4	3- #5 u(E)	n(E)
19	8 1/8	3- #5 u(E)	n(E)	5 3/4	3- #5 u(E)	n(E)
20	9 1/8	3- #5 u(E)	n(E)	5 3/4	3- #5 u(E)	n(E)

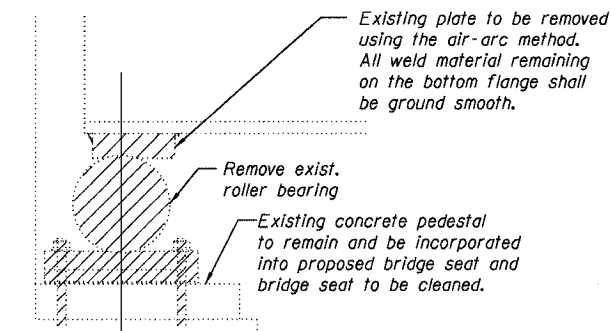

**EXISTING ABUT. ELEVATION
AT BEAMS 2 THRU 4**

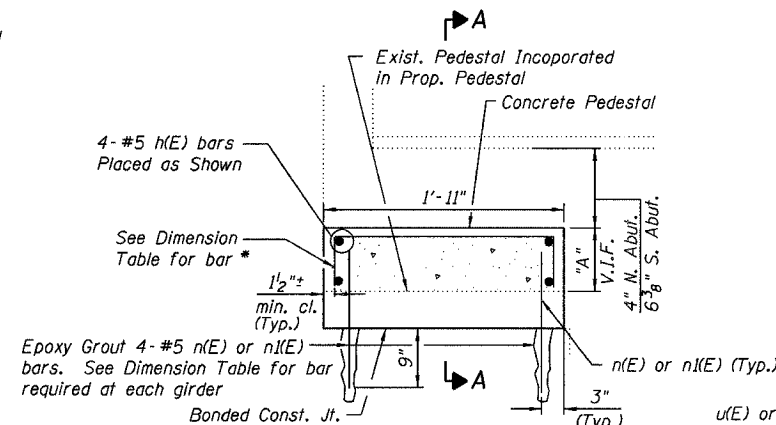

**PROPOSED ABUT. ELEVATION
AT BEAMS 2 THRU 4 AND 12 THRU 19**
(Brg. omitted for clarity)

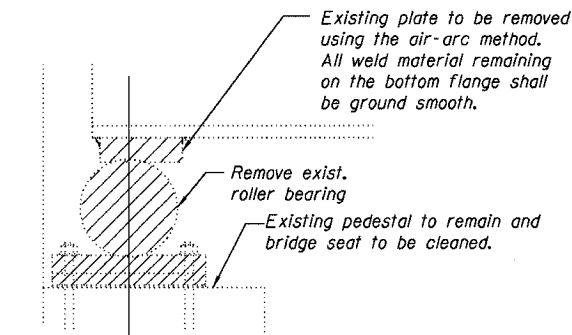
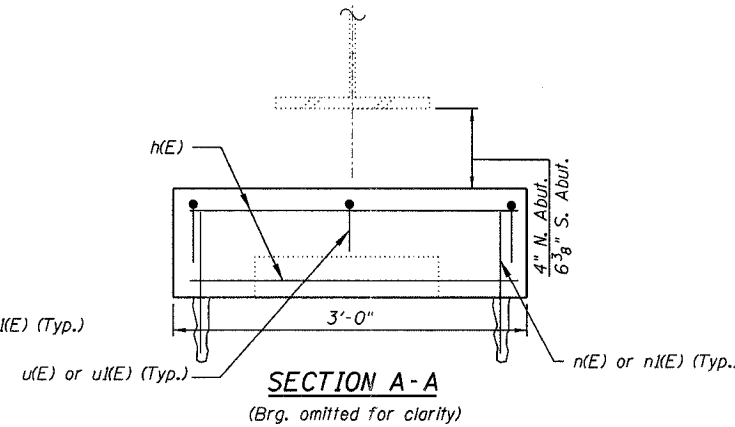

**EXISTING ABUT. ELEVATION
AT BEAMS 1 AND 5 THRU 20**

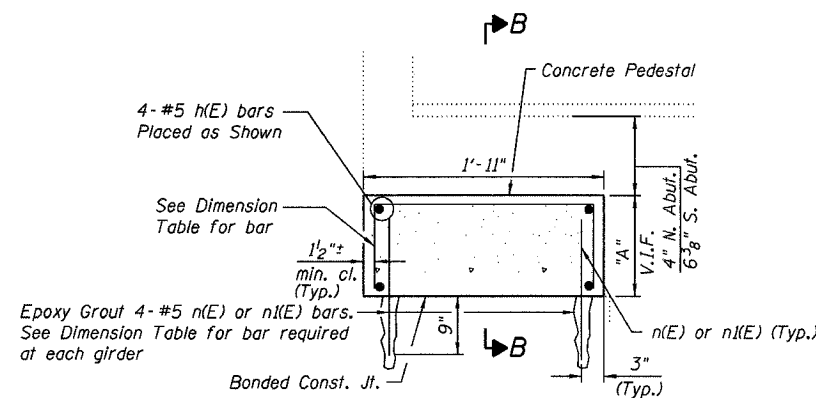

**PROPOSED ABUT. ELEVATION
AT BEAMS 1, 5 THRU 11 AND 20**
(Brg. omitted for clarity)

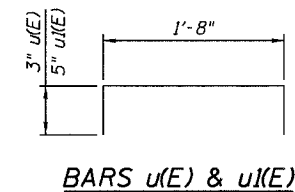
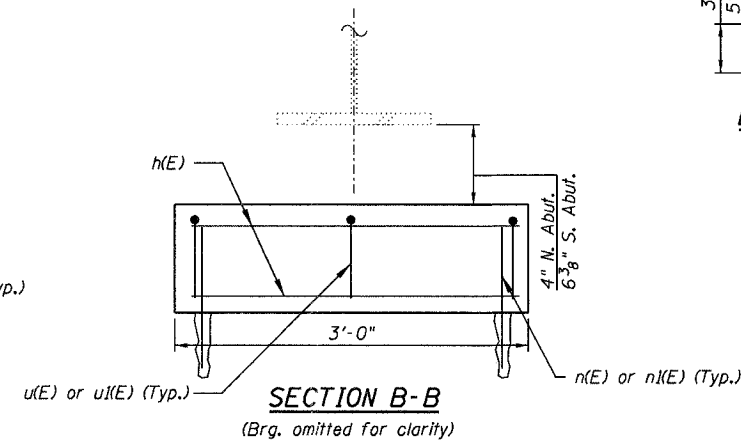

BILL OF MATERIAL

Bar	No.	Size	Length	Shape
n(E)	160	#5	2'-9"	—
n(E)	80	#5	1'-1"	—
n(E)	80	#5	1'-3"	—
u(E)	60	#5	2'-2"	┌
u(E)	60	#5	2'-6"	┌
Concrete Removal		Cu. Yd.	2.5	
Concrete Structures		Cu. Yd.	6.0	
Reinforcement Bars, Epoxy Coated		Pound	940	

* Cut u bars in the field if necessary to fit around existing pedestals

LEGEND

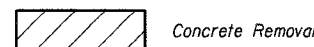

NOTES

- See Sheet No. 110 for proposed bearing details.
- Epoxy Grouting of Bars is included with the cost of Concrete Structures.
- The Contractor shall field verify all dimensions.

BEARING DETAILS III
F.A.I. 94/ (EDENS EXPRESSWAY)
OVER GOLF ROAD
COOK COUNTY
STATION 265+65.22
STRUCTURE NO. 016-0105

Revised 07/13/2007

DESIGNED -	JSD
CHECKED -	DWH
DRAWN -	JSD
CHECKED -	DWH

LOCHNER
H.W. LOCHNER, INC., CHICAGO, ILLINOIS

I:\2298\struct\dgn\0105ANC00.dgn