

STATE OF ILLINOIS  
DEPARTMENT OF TRANSPORTATION

ROUTE NO.	SECTION	COUNTY	TOTAL SHEETS	SHEET NO.
F.A.I. 94	2006-043 RS	COOK	135	104c
FED. ROAD DIST. NO. 7		ILLINOIS	FED. AID PROJECT	

Contract # 62747

When "A" is 3'-6" or less, the temporary concrete barrier shall be anchored to the new slab according to Detail I or Detail II. No anchorage is required when "A" is greater than 3'-6".

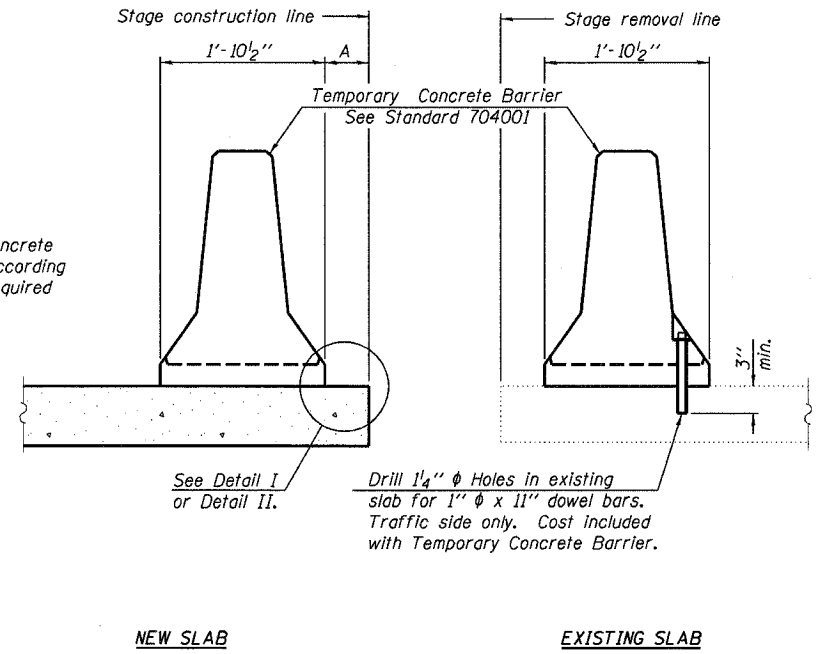

SECTIONS THRU SLAB

NOTES

Detail I - With Bar Splicer or Couplers:  
Connect one (1) 1"x7"x10" steel  $\bar{P}$  to the top layer of couplers with 2-5/8"  $\phi$  bolts screwed to coupler at approximate  $\bar{C}$  of each barrier panel.

Detail II - With Extended Reinforcement Bars:  
Connect one (1) 1"x7"x10" steel  $\bar{P}$  to the concrete slab with 2-5/8"  $\phi$  Expansion Anchors or cast in place inserts spaced between the top layer of reinforcement at approximate  $\bar{C}$  of each barrier panel.

Cost of anchorage is included with Temporary Concrete Barrier. The 1" x 7" x 10" plate shall not be removed until stage II construction forms and all reinforcement bars are in place and the concrete is ready to be placed.

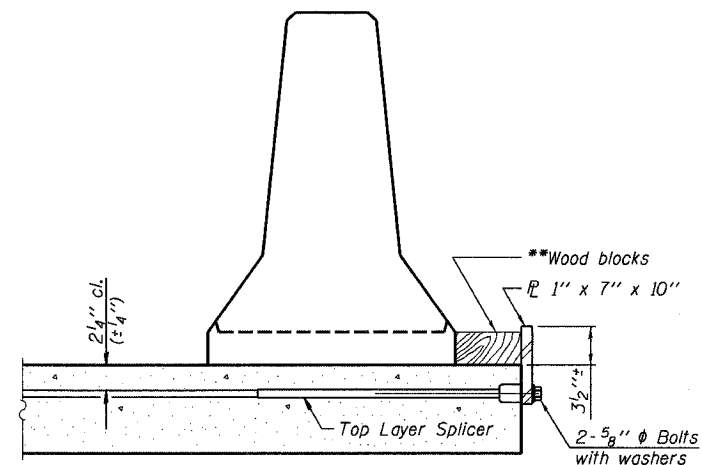

DETAIL I

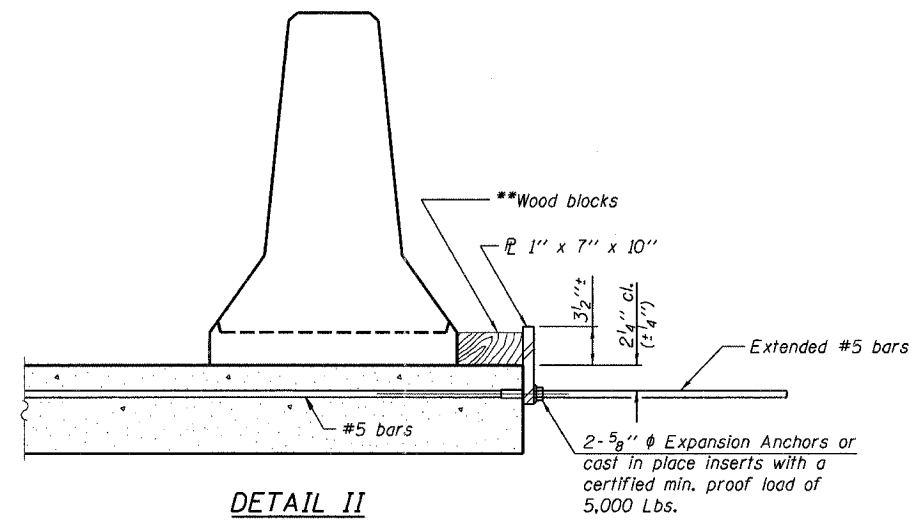

DETAIL II

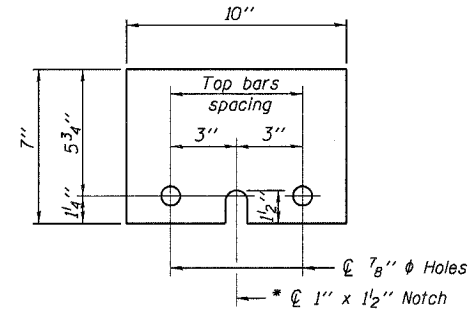

STEEL RETAINER  $\bar{P}$  1" x 7" x 10"

\* Required only with Detail II

\*\* Wood blocks may be omitted when required to provide minimum stage traffic lane width. When the wood blocks are omitted, the concrete barrier shall be in direct contact with the steel retainer plate.

DESIGNED -	GWS
CHECKED -	JSD
DRAWN -	EF
CHECKED -	JSD

**LOCHNER**  
H.W. LOCHNER, INC., CHICAGO, ILLINOIS

R-27

11-1-06

TEMPORARY CONCRETE BARRIER FOR  
STAGE CONSTRUCTION  
F.A.I. 94/ (EDENS EXPRESSWAY)  
OVER U.P.R.R.  
COOK COUNTY  
STATION 277+05.05  
STRUCTURE NO. 016-0103 & 016-0104

T:\2298\struct\dgn\0103COM10.dgn