

F. A. I. D. NO.	SECTION	COUNTY	TOTAL SHEETS	SHEET NO.
1607	07-00083-00-RS	COOK	016	001
STA.		TO STA.		
FED. ROAD DIST. NO.	BLANKS	FED. AID PROJECT		

CONTRACT #83940

STATE OF ILLINOIS
DEPARTMENT OF TRANSPORTATION
DIVISION OF HIGHWAYS

**PLANS FOR PROPOSED
FEDERAL AID HIGHWAY**

FAU 1607 154TH STREET
SOUTH PARK AVENUE (FAU 2921) TO WEST OF INTERSTATE 94 (FAI 94)
LOCAL AGENCY PRESERVATION PROGRAM
STREET RESURFACING
PROJECT: M-8003 (765)
SECTION NO.: 07-00083-00-RS
JOB NO.: C 91-169-07
VILLAGE OF SOUTH HOLLAND
COOK COUNTY

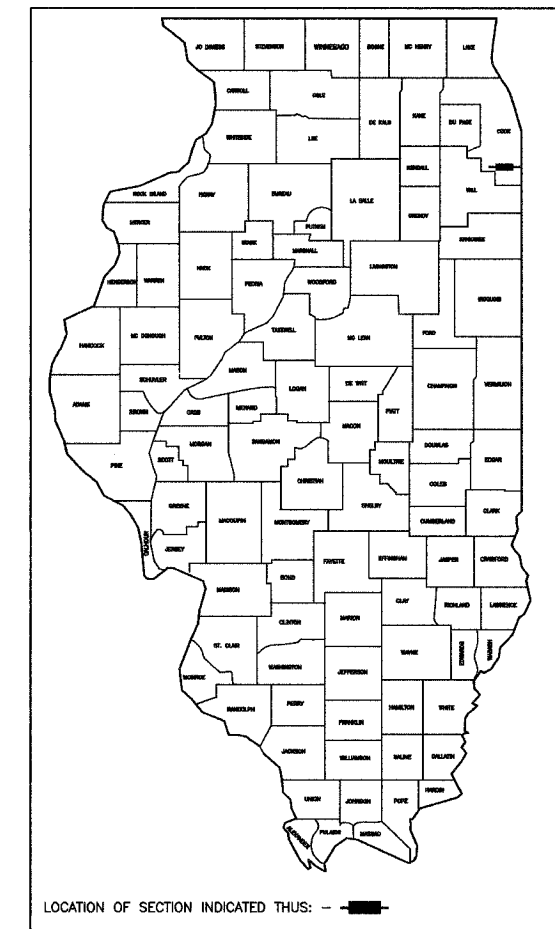

INDEX OF SHEETS

- 1 COVER SHEET, INDEX OF SHEETS, LOCATION MAP
- INDEX OF STATE STANDARDS
- 2 SUMMARY OF QUANTITIES
- 3 TYPICAL CROSS SECTIONS
- 4-6 PAVEMENT PLAN
- 7-9 STRIPING PLAN
- 10-16 IDOT DISTRICT 1 DETAILS

STATE STANDARDS

- 000001-04 STANDARD SYMBOLS, ABBREVIATIONS AND PATTERNS
- 280001-03 TEMPORARY EROSION CONTROL SYSTEMS
- 424001-04 CURB RAMPS FOR SIDEWALKS
- 442201-02 CLASS C AND D PATCHES
- 606001-03 CONCRETE CURB AND COMBINATION CONCRETE CURB & GUTTER
- 701701-04 URBAN LANE CLOSURE, MULTILANE INTERSECTION
- 701801-03 LANE CLOSURE, MULTILANE, 1W OR 2W, CROSSWALK OR SIDEWALK CLOSURE
- 702001-06 TRAFFIC CONTROL DEVICES
- 780001-01 TYPICAL PAVEMENT MARKINGS
- 781001-02 TYPICAL APPLICATIONS RAISED REFLECTIVE PAVEMENT MARKERS
- 886001 DETECTOR LOOP INSTALLATIONS
- 886006 TYPICAL LAYOUT FOR DETECTION LOOPS



END IMPROVEMENT
WEST OF INTERSTATE 94
STA 70+14

BEGIN IMPROVEMENT
SOUTH PARK AVENUE
STA 0+22

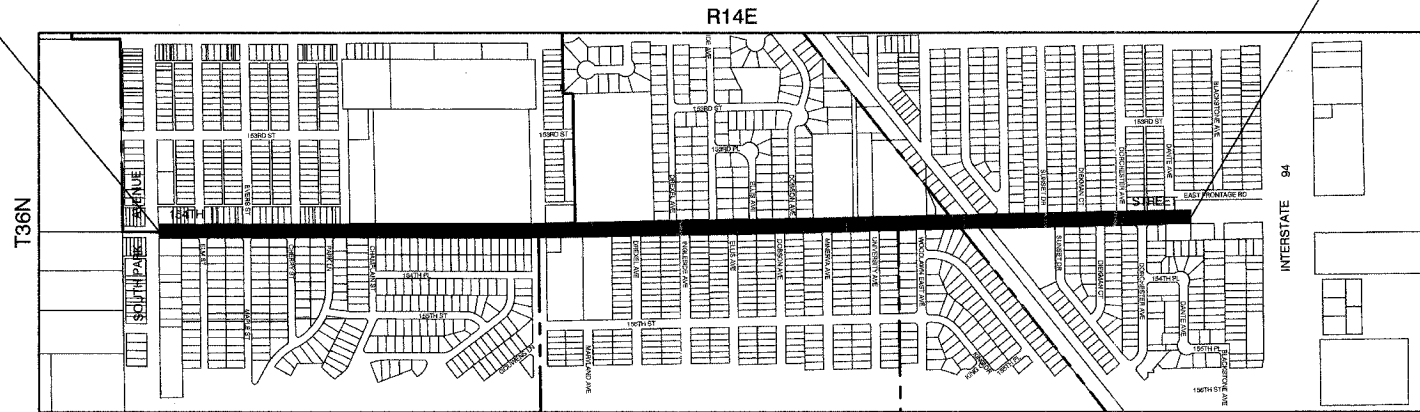
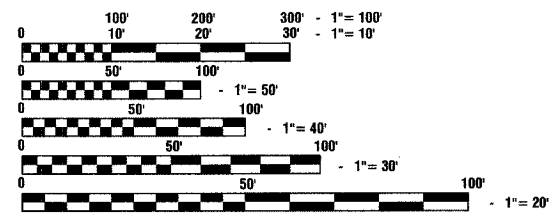

LOCATION MAP

- INDICATES PROPOSED IMPROVEMENT
GROSS LENGTH= 6,992 FEET = 1.32 MILES
NET LENGTH= 6,992 FEET = 1.32 MILES

154TH STREET ARTERIAL
ADT=9,000 (2007)
=10,000 (2030)
DESIGN SPEED=40 MPH
SPEED LIMIT=35 MPH

STATE OF ILLINOIS
DEPARTMENT OF TRANSPORTATION
DIVISION OF HIGHWAYS

APPROVED: 5/15 2007
Don A. DeBaff
PRESIDENT, VILLAGE OF SOUTH HOLLAND

PASSED: MAY 23 2007
Chad Cunningham
REGION ONE ENGINEER OF LOCAL ROADS & STREETS

RELEASED FOR
BID BASED ON
LIMITED REVIEW
May 24 2007
Diane O'Keefe
DEPUTY DIRECTOR OF HIGHWAYS, REGION ONE ENGINEER

PRINTED BY THE AUTHORITY OF
THE STATE OF ILLINOIS

PREPARED BY OR UNDER THE
DIRECT SUPERVISION OF:
[Signature]
5/15/07

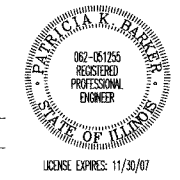

FULL SIZE PLANS HAVE BEEN PREPARED USING STANDARD
ENGINEERING SCALES, REDUCED SIZED PLANS WILL NOT
CONFORM TO STANDARD SCALES, IN MAKING MEASUREMENTS
ON REDUCED PLANS, THE ABOVE SCALES MAY BE USED.

J. U. L. I. E.
JOINT UTILITY LOCATION INFORMATION FOR EXCAVATION
1-800-892-0123

CONTRACT NO. 83940

I.D.O.T. FEDERAL AID DESIGN ENGINEER: KEVIN STALLWORTH 847-705-4169
CONSULTANTS: ROBINSON ENGINEERING, LTD. 708-331-6700
CONTACT ENGINEER: JAROD BRADFIELD

F. A. IL. NO.	SECTION	COUNTY	TOTAL SHEETS	SHEET NO.
1607	07-00114-00-RS 07-00083-00-RS	COOK	016	002
STA.	TO STA.			
FED. ROAD DIST. NO.	SLANDS	FED. AID PROJECT		

CONTRACT #83940

SUMMARY OF QUANTITIES					VILLAGE OF S. HOLLAND	VILLAGE OF DOLTON
S.I.	CODE NO.	PAY ITEM	UNIT	QUAN		
	25000400	NITROGEN FERTILIZER NUTRIENT	POUND	12	6.0	6.0
	25000500	PHOSPHORUS FERTILIZER NUTRIENT	POUND	12	6.0	6.0
	25000600	POTASSIUM FERTILIZER NUTRIENT	POUND	12	6.0	6.0
	25200110	SODDING, SALT TOLERANT	SQ YD	600	300.0	300.0
	40201000	AGGREGATE FOR TEMPORARY ACCESS	TON	200	100.0	100.0
	40600100	BITUMINOUS MATERIALS (PRIME COAT)	GALLON	4736	2131.0	2605.0
	40600300	AGGREGATE (PRIME COAT)	TON	101	46.0	55.0
	40600895	CONSTRUCTING TEST STRIP	EACH	1	0.5	0.5
	40600982	HOT-MIX ASPHALT SURFACE REMOVAL - BUTT JOINT	SQ YD	1036	466.0	570.0
	40603335	HOT-MIX ASPHALT SURFACE COURSE, MIX "D", N50	TON	3763	1510.0	2253.0
	42300300	PORTLAND CEMENT CONCRETE DRIVEWAY PAVEMENT, 7 INCH	SQ YD	100	50.0	50.0
	42400200	PORTLAND CEMENT CONCRETE SIDEWALK 5 INCH	SQ FT	2450	1225.0	1225.0
	42400800	DETECTABLE WARNINGS	SQ FT	600	300.0	300.0
	44000196	HOT-MIX ASPHALT SURFACE REMOVAL, SPECIAL	SQ YD	8996	4048.0	4948.0
	XX006948	HOT-MIX ASPHALT DRIVEWAY REMOVAL AND REPLACEMENT	SQ YD	100	50.0	50.0
	44000600	SIDEWALK REMOVAL	SQ FT	2450	1225.0	1225.0
	44001700	COMBINATION CONCRETE CURB AND GUTTER REMOVAL AND REPLACEMENT	FOOT	700	350.0	350.0
	44201737	CLASS D PATCHES, TYPE I, 8 INCH	SQ YD	100	50.0	50.0
	44201741	CLASS D PATCHES, TYPE II, 8 INCH	SQ YD	300	150.0	150.0
	44201745	CLASS D PATCHES, TYPE III, 8 INCH	SQ YD	400	200.0	200.0
	44201747	CLASS D PATCHES, TYPE IV, 8 INCH	SQ YD	1550	775.0	775.0
	60250200	CATCH BASINS TO BE ADJUSTED	EACH	40	20.0	20.0
	60252800	CATCH BASINS TO BE RECONSTRUCTED	EACH	2	1.0	1.0
	60255500	MANHOLES TO BE ADJUSTED	EACH	60	30.0	30.0
	60255800	MANHOLES TO BE ADJUSTED WITH NEW TYPE 1 FRAME, CLOSED LID	EACH	4	2.0	2.0
	60258200	MANHOLES TO BE RECONSTRUCTED WITH NEW TYPE 1 FRAME, CLOSED LID	EACH	2	1.0	1.0
	70102620	TRAFFIC CONTROL AND PROTECTION, STANDARD 701501	L SUM	1	0.5	0.5
	70102625	TRAFFIC CONTROL AND PROTECTION, STANDARD 701606	L SUM	1	0.5	0.5
	70102635	TRAFFIC CONTROL AND PROTECTION, STANDARD 701701	L SUM	1	0.5	0.5
	70102640	TRAFFIC CONTROL AND PROTECTION, STANDARD 701801	L SUM	1	0.5	0.5
	70300100	SHORT-TERM PAVEMENT MARKING	FOOT	4000	2000.0	2000.0
*	78000100	THERMOPLASTIC PAVEMENT MARKING - LETTERS AND SYMBOLS	SQ FT	300	150.0	150.0
*	78000200	THERMOPLASTIC PAVEMENT MARKING - LINE 4"	FOOT	16800	8400.0	8400.0
*	78000400	THERMOPLASTIC PAVEMENT MARKING - LINE 6"	FOOT	2400	1200.0	1200.0
*	78000650	THERMOPLASTIC PAVEMENT MARKING - LINE 24"	FOOT	2000	1000.0	1000.0
*	78100100	RAISED REFLECTIVE PAVEMENT MARKER	EACH	450	225.0	225.0
*	88600600	DETECTOR LOOP REPLACEMENT	FOOT	1142	571.0	571.0
	X0324096	HOT IN-PLACE RECYCLING	SQ YD	43760	19692.0	24068.0
	X0322052	ASPHALT REJUVENATING AGENT	GALLON	4376	1969.0	2407.0
	X4067107	POLYMERIZED LEVELING BINDER (MACHINE METHOD), IL-4.75, N50	TON	1240	558.0	6820
	67100100	MOBILIZATION	L SUM	1	0.5	0.5

GENERAL NOTES:

- BEFORE STARTING ANY EXCAVATION, THE CONTRACTOR SHALL CALL "J.U.L.I.E." AT (800) 892-0123 AT (312) 744-7000 FOR FIELD LOCATIONS OF BURIED ELECTRIC, TELEPHONE AND GAS UTILITIES. (48 HOUR NOTIFICATION IS REQUIRED).
- UTILITIES INDICATED ON THE PLANS ARE PROVIDED FOR THE CONTRACTORS USE AND ARE BASED UPON INFORMATION AVAILABLE AT THE TIME OF THE ADVERTISEMENT FOR BIDS. THE OWNER AND ENGINEER DO NOT GUARANTEE THE ACCURACY OF UTILITIES INFORMATION.
- IT SHALL BE THE CONTRACTOR'S RESPONSIBILITY TO VERIFY ALL DIMENSIONS AND CONDITIONS EXISTING IN THE FIELD PRIOR TO CONSTRUCTION AND ORDERING OF MATERIALS.
- SCHEDULES INCLUDED IN THE PLANS HAVE BEEN PREPARED FROM FIELD NOTES. EXACT LOCATIONS FOR PATCHING SHALL BE DETERMINED IN THE FIELD BY THE ENGINEER.
- ANY REFERENCE TO STANDARDS THROUGHOUT THE PLANS OR SPECIAL PROVISIONS SHALL BE INTERPRETED TO BE THE LATEST STANDARDS OF THE ILLINOIS DEPARTMENT OF TRANSPORTATION.
- THE NOMINAL THICKNESS OF BITUMINOUS MIXTURE STATED IN THE SPECIFICATIONS IS THE NOMINAL THICKNESS. DEVIATIONS FROM THE NOMINAL THICKNESS WILL BE PERMITTED WHEN SUCH DEVIATIONS OCCUR DUE TO IRREGULARITIES IN THE EXISTING SURFACE OR BASE ON WHICH THE BITUMINOUS SURFACE IS PLACED.

* - INDICATES SPECIALTY ITEMS

REVISIONS	
NAME	DATE

ILLINOIS DEPARTMENT OF TRANSPORTATION

154TH STREET
STREET RESURFACING
SUMMARY OF QUANTITIES

SCALE: VERT. NA
HORIZ. NA
DATE 04-16-07

DRAWN BY PS/RG
CHECKED BY PKB

ROBINSON ENGINEERING, LTD.
17000 SOUTH PARK AVENUE, SOUTH HOLLAND, ILLINOIS 60470
(708) 891-8700 FAX (708) 381-9620
ILLINOIS DESIGN FIRM REGISTRATION NO. 150001128 06187-QUAN-01

F. A. U. NO.	SECTION	COUNTY	TOTAL SHEETS	SHEET NO.
1607	07-00083-00-RS	COOK	016	003
STA.	TO STA.			
FED. ROAD DIST. NO.	ALJOB	FED. AID PROJECT		

CONTRACT #83940

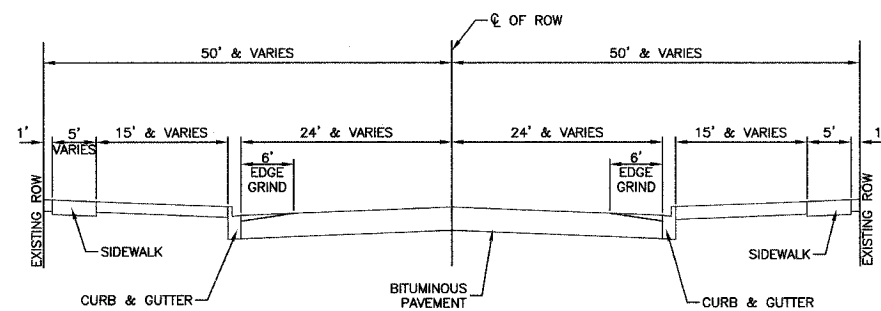

EXISTING TYPICAL SECTION
VILLAGES OF DOLTON AND SOUTH HOLLAND
154TH STREET

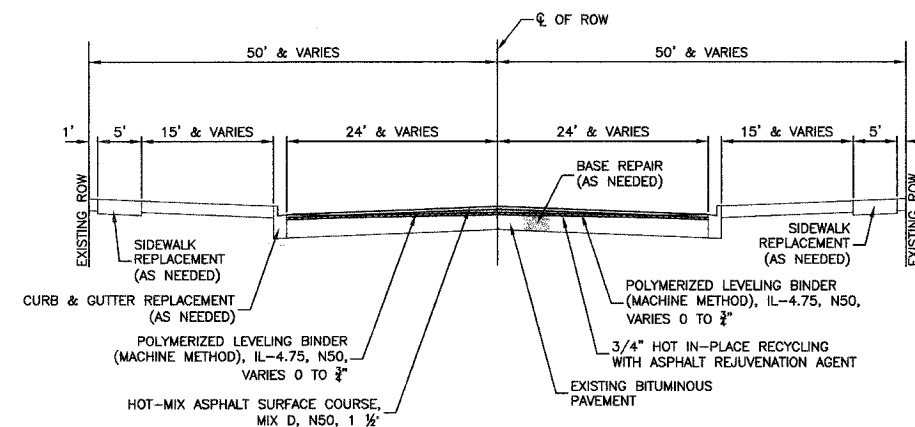

PROPOSED TYPICAL SECTION
VILLAGES OF DOLTON AND SOUTH HOLLAND
154TH STREET

HOT-MIX ASPHALT MIXTURE REQUIREMENTS

ITEM	AC TYPE	VOIDS
HOT-MIX ASPHALT SURFACE COURSE, MIX D, N50 (IL-9.5 mm), 1 1/2"	PG 64-22	4% @ 50 GYR
POLYMERIZED LEVELING BINDER (MACHINE METHOD), IL-4.75, N50 VARIES 0" to 3/4"	SBS/SBR PG 76-28/-22	4% @ 50 GYR
DRIVEWAYS		
HOT-MIX ASPHALT SURFACE COURSE, MIX C, N50 (IL-9.5 mm), 2"	PG 64-22	4% @ 50 GYR
HOT-MIX ASPHALT BASE COURSE (HMA BINDER IL-19 mm), PE-6", CE-8"	PG 64-22*	4% @ 50 GYR
PATCHING		
CLASS D PATCHES, TYPE I, II, III, IV, 8" (HMA BINDER IL-19 mm)	PG 64-22/58-22*	4% @ 70 GYR
HMA REPLACEMENT OVER PATCHES (BINDER IL-19 mm)	PG 64-22/58-22*	4% @ 70 GYR

- NOTE:
 1. THE UNIT WEIGHT USED TO CALCULATE ALL HOT-MIX ASPHALT SURFACE MIXTURE QUANTITIES IS 112 LBS/SY/IN.
 2. *WHEN RAP EXCEEDS 20%, THE NEW ASPHALT BINDER IN THE MIX SHALL BE PG 58-22

REVISIONS	
NAME	DATE

ILLINOIS DEPARTMENT OF TRANSPORTATION

**154TH STREET
STREET RESURFACING
TYPICAL CROSS SECTIONS**

SCALE: VERT. NA
HORIZ. NA
DATE 04-16-07

DRAWN BY PS/RG
CHECKED BY PKB

F. A. U. NO.	SECTION	COUNTY	TOTAL SHEETS	SHEET NO.
1807	07-00144-00-RS	COOK	016	004
STA. 0+22	TO STA. 25+00			
FED. ROAD DIST. NO.	LINE	FED. AID PROJECT		

CONTRACT #83940

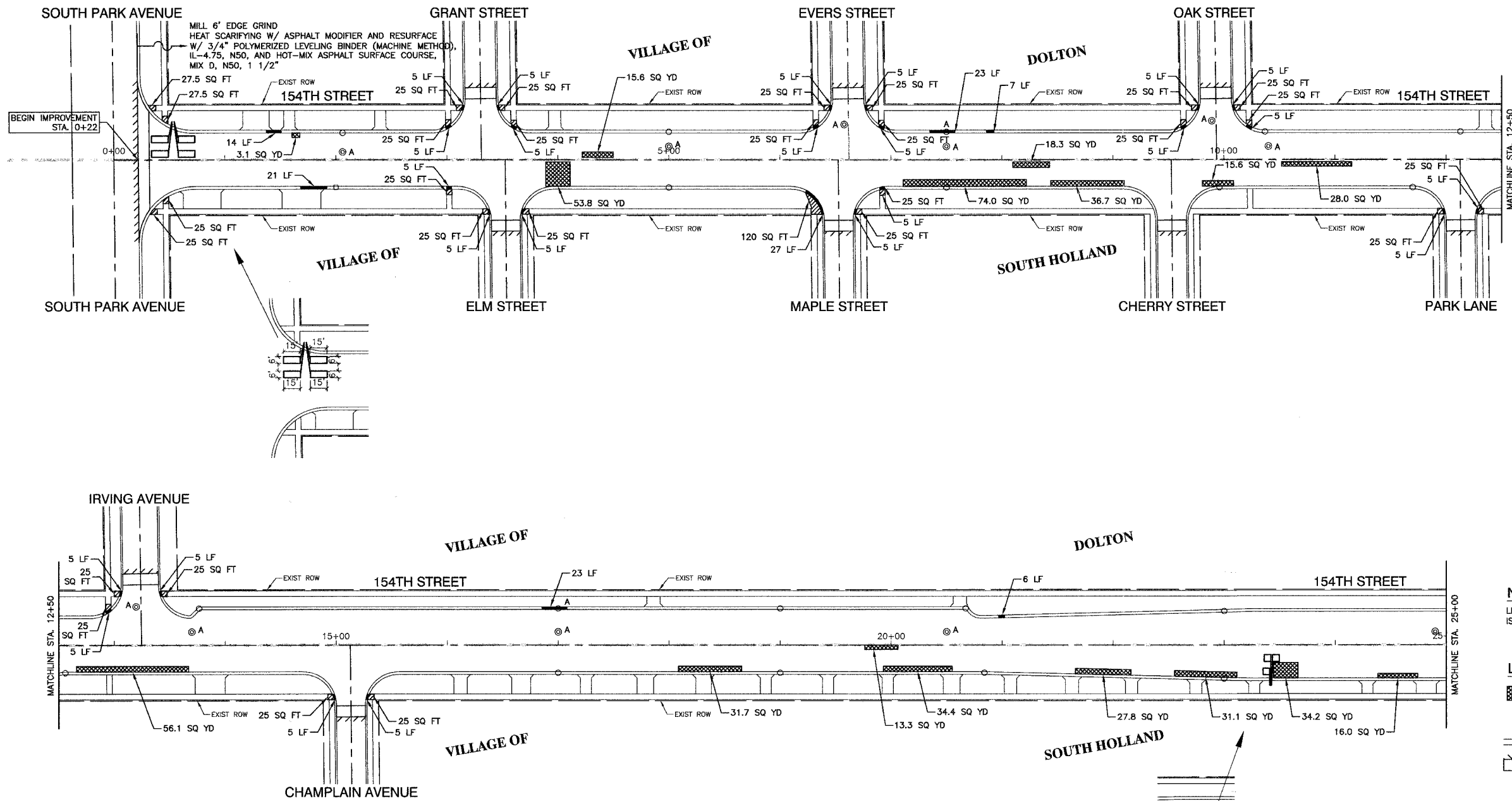

MILL 6" EDGE GRIND
HEAT SCARIFYING W/ ASPHALT MODIFIER AND RESURFACE
W/ 3/4" POLYMERIZED LEVELING BINDER (MACHINE METHOD),
IL-4.75, N50, AND HOT-MIX ASPHALT SURFACE COURSE,
MIX D, N50, 1 1/2"

NOTE:
LIMIT OF CONSTRUCTION ON ALL SIDE STREETS
IS THE RADIUS RETURN PLUS 10' BUTT JOINT

- LEGEND**
- BITUMINOUS PAVEMENT REPAIR
 - CONCRETE SIDEWALK REMOVAL AND REPLACEMENT
 - CURB REMOVAL
 - 10' BUTT JOINT (UNLESS OTHERWISE INDICATED)
 - STRUCTURE TO BE ADJUSTED
 - STRUCTURE TO BE RECONSTRUCTED
 - DETECTOR LOOP

REVISIONS	
NAME	DATE

ILLINOIS DEPARTMENT OF TRANSPORTATION

**154TH STREET
STREET RESURFACING
PAVEMENT PLAN**

VERT. NA
SCALE: HORIZ. 1"=50'
DATE 04-16-07

DRAWN BY PS/RG
CHECKED BY PKB

ROBINSON ENGINEERING, LTD.
11000 SOUTH PARK AVENUE, SOUTH HOLLAND, ILLINOIS 60473
(708) 381-8700 FAX (708) 381-9825
ILLINOIS DESIGN FIRM REGISTRATION NO. 184001201

06167-PLAN-01

F. A. U. NO.	SECTION	COUNTY	TOTAL SHEETS	SHEET NO.
1607	07-00114-00-RP 07-00083-00-RS	COOK	016	005
STA. 25+00		TO STA. 50+00		
FED. ROAD DIST. NO.	ALIGNED	FED. AID PROJECT		

CONTRACT #83940

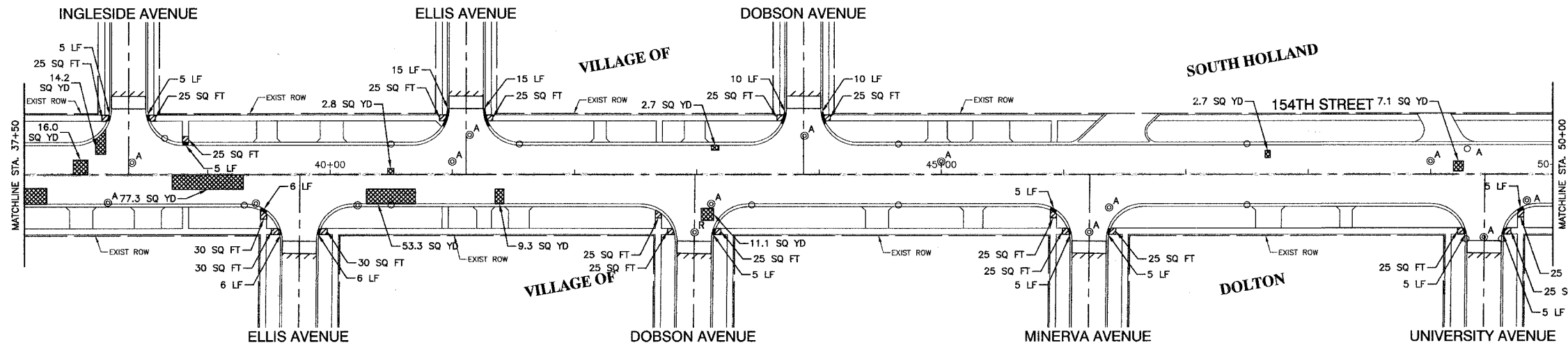
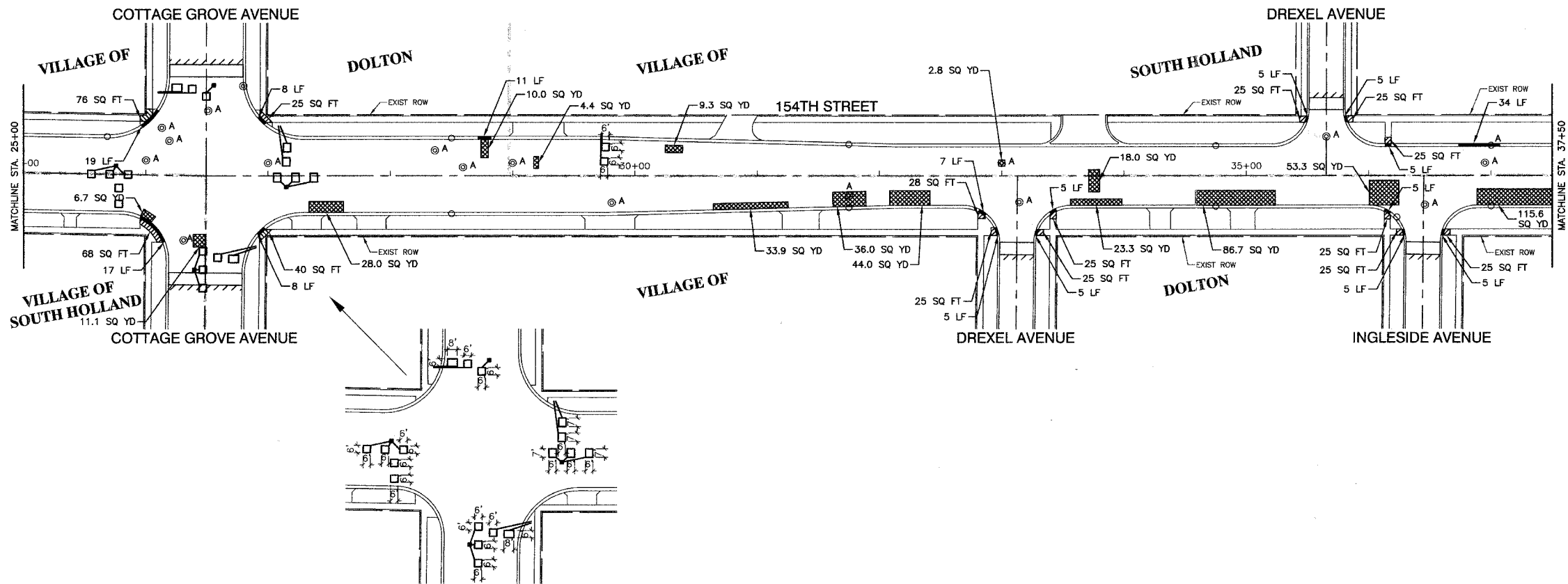

NOTE:
LIMIT OF CONSTRUCTION ON ALL SIDE STREETS IS THE RADIUS RETURN PLUS 10' BUTT JOINT

- LEGEND**
- BITUMINOUS PAVEMENT REPAIR
 - CONCRETE SIDEWALK REMOVAL AND REPLACEMENT
 - CURB REMOVAL
 - 10' BUTT JOINT (UNLESS OTHERWISE INDICATED)
 - STRUCTURE TO BE ADJUSTED
 - STRUCTURE TO BE RECONSTRUCTED
 - DETECTOR LOOP

REVISIONS	
NAME	DATE

ILLINOIS DEPARTMENT OF TRANSPORTATION

154TH STREET STREET RESURFACING PAVEMENT PLAN

SCALE: VERT. NA
HORIZ. 1"=50'

DATE 04-11-07

DRAWN BY PS/RG
CHECKED BY PKB

ROBINSON ENGINEERING, LTD.
17000 SOUTH PAVEN AVENUE, SOUTH HOLLAND, ILLINOIS 60470
(708) 331-6700 FAX (708) 331-3625
ILLINOIS DESIGN FIRM REGISTRATION NO. 198001128

06187-PLAN-01

F. A. U. NO.	SECTION	COUNTY	TOTAL SHEETS	SHEET NO.
1807	07-00083-00-RS	COOK	016	006
STA. 50+00		TO STA. 70+14		
FED. ROAD DIST. NO.	ILLINOIS	FED. AID PROJECT		

CONTRACT #83940

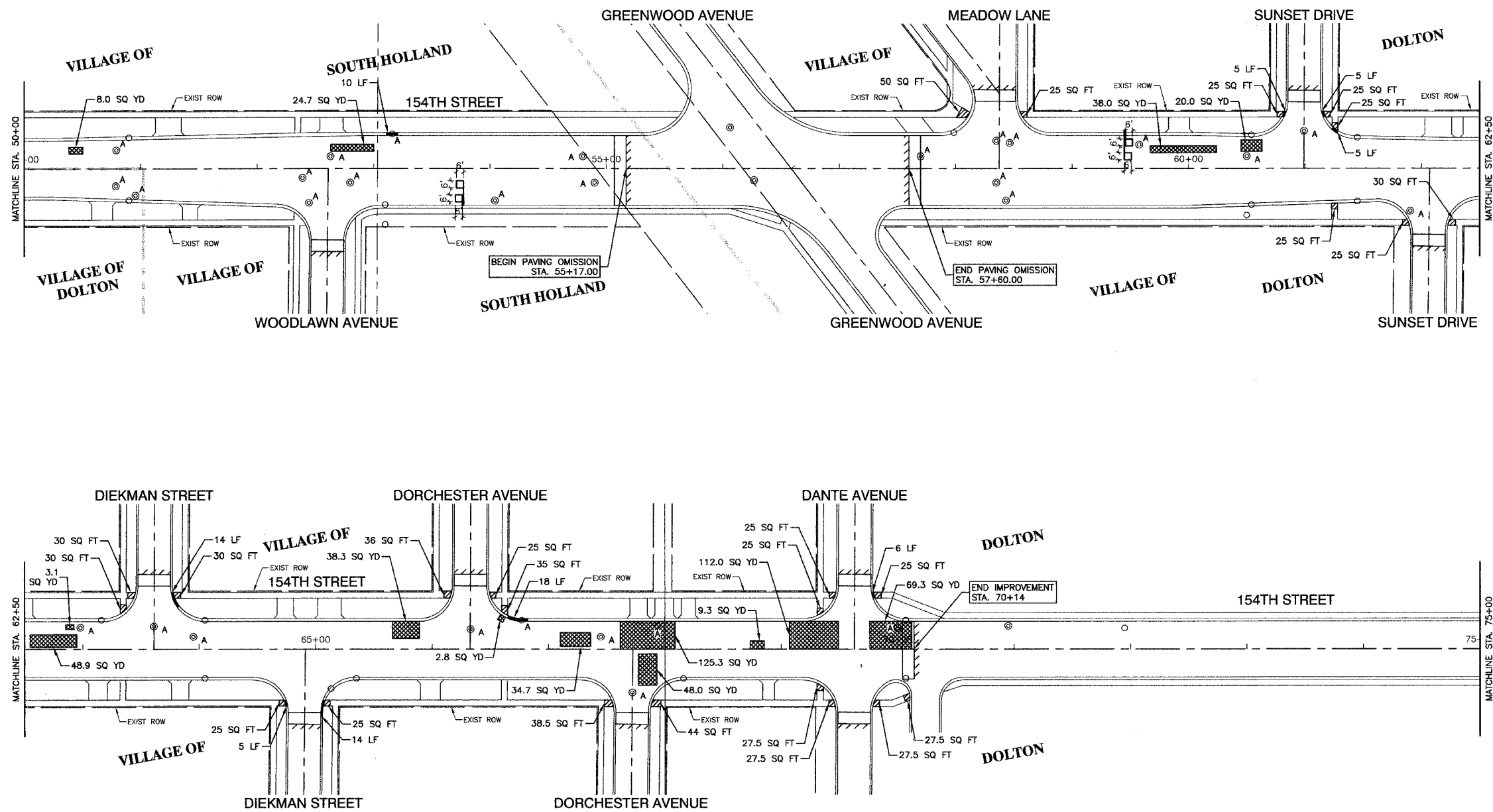

NOTE:
LIMIT OF CONSTRUCTION ON ALL SIDE STREETS IS THE RADIUS RETURN PLUS 10' BUTT JOINT

- LEGEND**
- BITUMINOUS PAVEMENT REPAIR
 - CONCRETE SIDEWALK REMOVAL AND REPLACEMENT
 - CURB REMOVAL
 - 10' BUTT JOINT (UNLESS OTHERWISE INDICATED)
 - STRUCTURE TO BE ADJUSTED
 - STRUCTURE TO BE RECONSTRUCTED
 - DETECTOR LOOP

REVISIONS	
NAME	DATE

ILLINOIS DEPARTMENT OF TRANSPORTATION

**154TH STREET
STREET RESURFACING
PAVEMENT PLAN**

SCALE: VERT. NA
HORIZ. 1"=50'
DATE: 04-11-07

DRAWN BY: PS/RG
CHECKED BY: PKB

ROBINSON ENGINEERING, LTD.
17005 SOUTH PARK AVENUE, SOUTH HOLLAND, ILLINOIS 60470
(708) 321-4000 FAX (708) 321-3825
ILLINOIS DESIGN FIRM REGISTRATION NO. 126011728 06187-PLAN.01

F. A. L. NO.	SECTION	COUNTY	TOTAL SHEETS	SHEET NO.
1607	07-00083-00-RS	COOK	016	007
STA. 0+22	TO STA. 25+00			
FED. ROAD DIST. NO.	SLAB	FED. AID PROJECT		

CONTRACT #83940

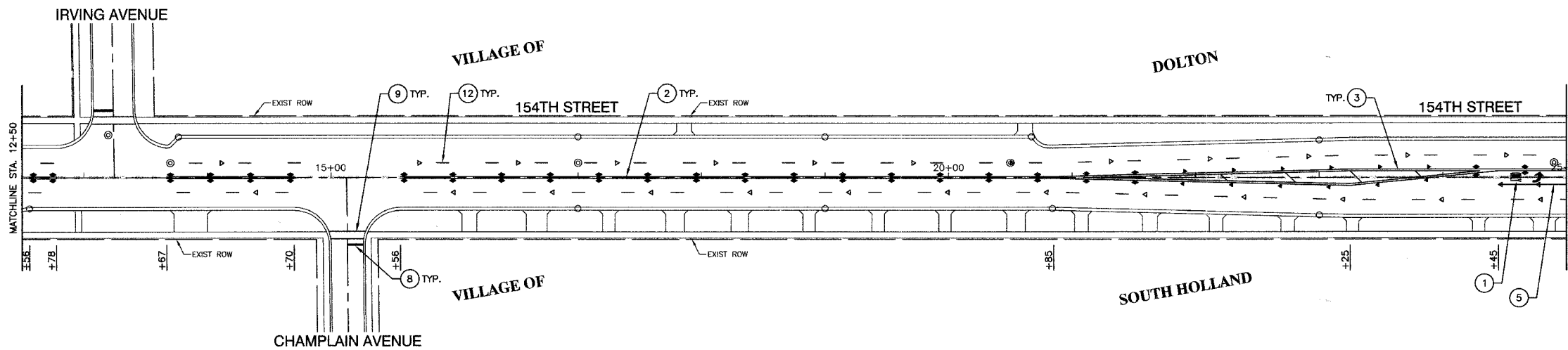
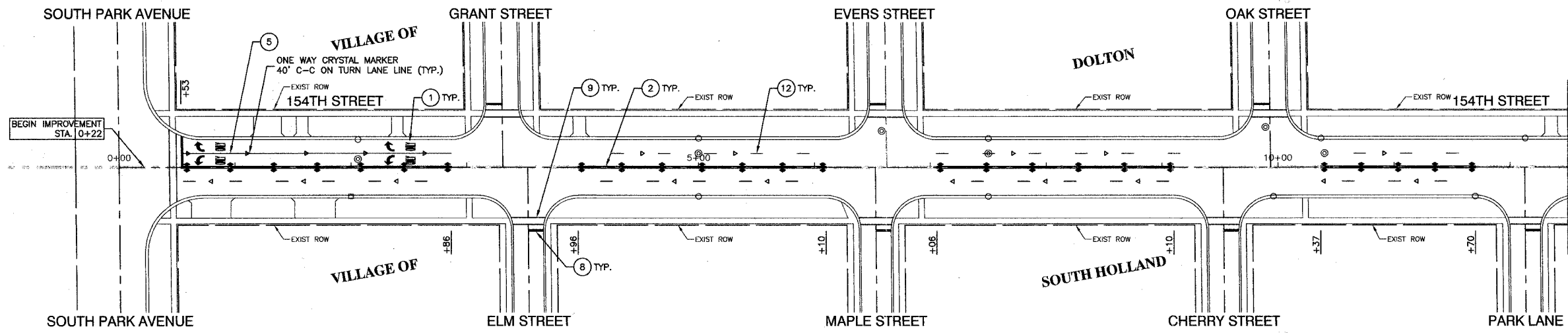

NOTE:

SEE IDOT STANDARD TC-13 FOR PAVEMENT MARKING DETAILS
ALL LEGEND ITEMS ARE THERMOPLASTIC PAVEMENT MARKING OF THE WIDTH AND TYPE SPECIFIED

PAVEMENT MARKING LEGEND

- ① WHITE LETTERS & SYMBOLS
- ② DOUBLE 4" YELLOW CENTERLINE (11" C/C)
- ③ DOUBLE YELLOW MEDIAN OUTLINE (11" C/C)
- ④ 4" YELLOW LINE
- ⑤ 4" WHITE EDGE LINE
- ⑥ 6" WHITE LANE LINE
- ⑦ 6" WHITE SKIP-DASH LINE (2' LINE - 6' SPACE)
- ⑧ 12" YELLOW DIAGONAL LINE (20' C/C)
- ⑨ 24" WHITE STOP BAR
- ⑩ 6" WHITE CROSSWALK (6' C/C)
- ⑪ 12" WHITE CROSSWALK (3' C/C)
- ⑫ 12" WHITE LINE (45° ANGLE, 20' C/C)
- ⑬ 4" WHITE SKIP - DASH LINE (10' LINE - 30' SPACE)
- ⑭ 4" YELLOW SKIP - DASH LINE (10' LINE - 30' SPACE)
- ▲ ONE-WAY AMBER MARKER 40' C/C UNLESS OTHERWISE INDICATED
- ◄ ONE-WAY CRYSTAL MARKER 80' C/C UNLESS OTHERWISE INDICATED
- ◆ TWO-WAY AMBER MARKER 40' C/C UNLESS OTHERWISE INDICATED
- ⊠ TRAFFIC SIGN

REVISIONS	
NAME	DATE

ILLINOIS DEPARTMENT OF TRANSPORTATION

154TH STREET STREET RESURFACING STRIPING PLAN

SCALE: VERT. NA
HORIZ. 1"=50'
DATE: 04-11-07
DRAWN BY: PS/RG
CHECKED BY: PKB

F. A. U. NO.	SECTION	COUNTY	TOTAL SHEETS	SHEET NO.
1607	07-00114-00-RS 07-00083-00-RS	COOK	016	008
STA. 25+00	TO STA. 50+00			
FED. ROAD DIST. NO.	LANDS	FED. RD PROJECT		

CONTRACT #83940

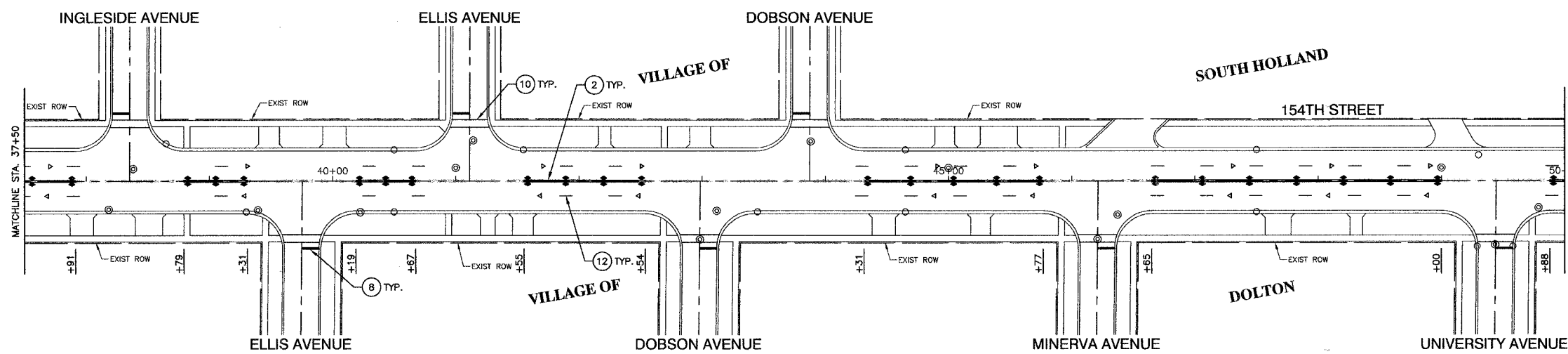
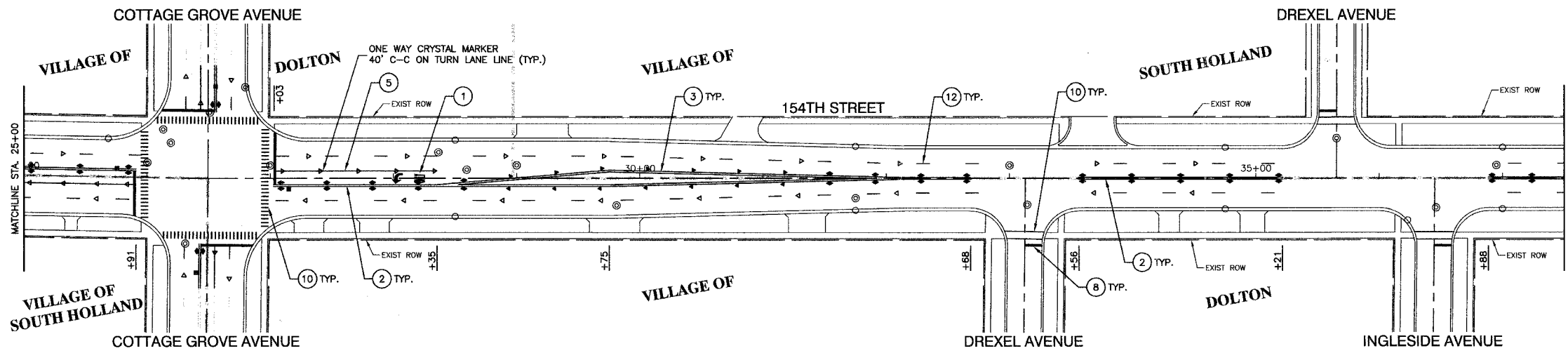

NOTE:

SEE IDOT STANDARD TC-13 FOR PAVEMENT MARKING DETAILS
ALL LEGEND ITEMS ARE THERMOPLASTIC PAVEMENT MARKING OF THE WIDTH AND TYPE SPECIFIED

PAVEMENT MARKING LEGEND

- ① WHITE LETTERS & SYMBOLS
- ② DOUBLE 4" YELLOW CENTERLINE (11" C/C)
- ③ DOUBLE YELLOW MEDIAN OUTLINE (11" C/C)
- ④ 4" YELLOW LINE
- ⑤ 4" WHITE EDGE LINE
- ⑥ 6" WHITE LANE LINE
- ⑦ 6" WHITE SKIP-DASH LINE (2' LINE - 6' SPACE)
- ⑧ 12" YELLOW DIAGONAL LINE (20" C/C)
- ⑨ 24" WHITE STOP BAR
- ⑩ 6" WHITE CROSSWALK (6' C/C)
- ⑪ 12" WHITE CROSSWALK (3' C/C)
- ⑫ 12" WHITE LINE (45° ANGLE, 20" C/C)
- ⑬ 4" WHITE SKIP - DASH LINE (10' LINE - 30' SPACE)
- ⑭ 4" YELLOW SKIP - DASH LINE (10' LINE - 30' SPACE)
- ▲ ONE-WAY AMBER MARKER 40" C/C UNLESS OTHERWISE INDICATED
- ◀ ONE-WAY CRYSTAL MARKER 80" C/C UNLESS OTHERWISE INDICATED
- ◆ TWO-WAY AMBER MARKER 40" C/C UNLESS OTHERWISE INDICATED
- ⊠ TRAFFIC SIGN

REVISIONS	
NAME	DATE

ILLINOIS DEPARTMENT OF TRANSPORTATION

**154TH STREET
STREET RESURFACING
STRIPING PLAN**

SCALE: VERT. NA
HORIZ. 1"=50'
DATE 04-11-07
DRAWN BY PS/RG
CHECKED BY PKB

F. A. L. NO.	SECTION	COUNTY	TOTAL SHEETS	SHEET NO.
1607	07-00114-06-RS 07-00083-00-RS	COOK	016	009
STA. 50+00	TO STA. 70+14			
FED. ROAD DIST. NO.	LIMITS	FED. AID PROJECT		

CONTRACT #83940

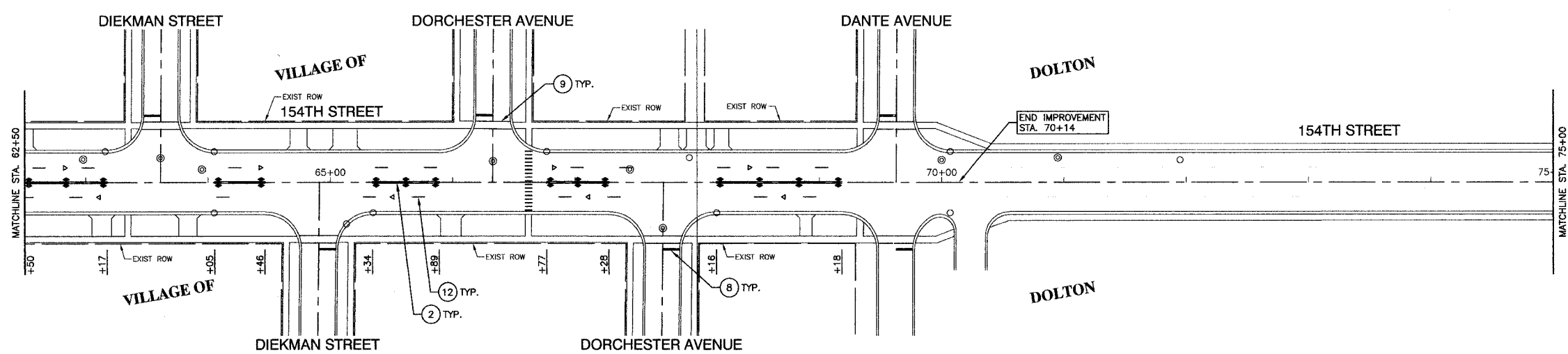
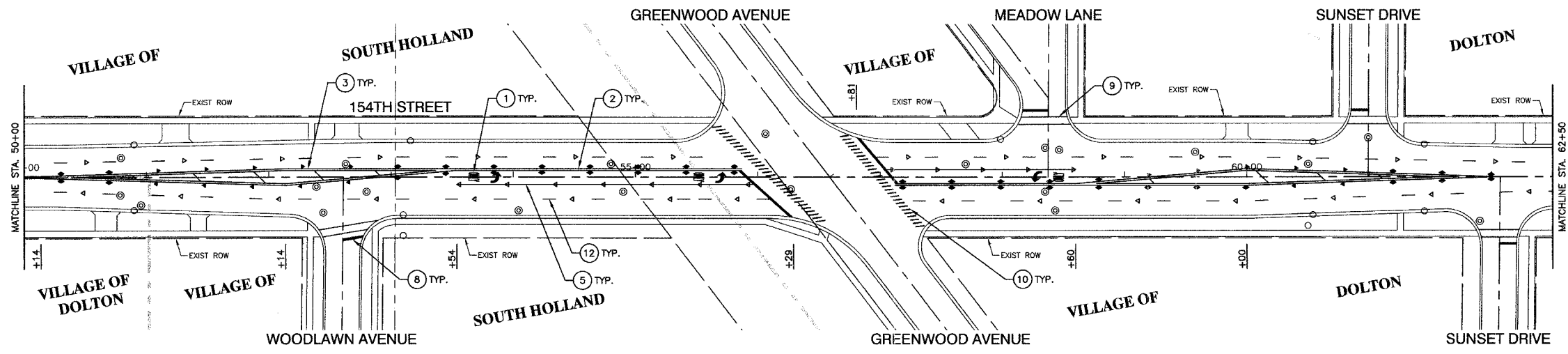

NOTE:

SEE IDOT STANDARD TC-13 FOR PAVEMENT MARKING DETAILS
ALL LEGEND ITEMS ARE THERMOPLASTIC PAVEMENT MARKING OF THE WIDTH AND TYPE SPECIFIED

PAVEMENT MARKING LEGEND

- ① WHITE LETTERS & SYMBOLS
- ② DOUBLE 4" YELLOW CENTERLINE (11" C/C)
- ③ DOUBLE YELLOW MEDIAN OUTLINE (11" C/C)
- ④ 4" YELLOW LINE
- ⑤ 4" WHITE EDGE LINE
- ⑥ 6" WHITE LANE LINE
- ⑦ 6" WHITE SKIP-DASH LINE (2' LINE - 6' SPACE)
- ⑧ 12" YELLOW DIAGONAL LINE (20' C/C)
- ⑨ 24" WHITE STOP BAR
- ⑩ 6" WHITE CROSSWALK (6' C/C)
- ⑪ 12" WHITE CROSSWALK (3' C/C)
- ⑫ 12" WHITE LINE (45° ANGLE, 20' C/C)
- ⑬ 4" WHITE SKIP - DASH LINE (10' LINE - 30' SPACE)
- ⑭ 4" YELLOW SKIP - DASH LINE (10' LINE - 30' SPACE)
- ◀ ONE-WAY AMBER MARKER 40' C/C UNLESS OTHERWISE INDICATED
- ◁ ONE-WAY CRYSTAL MARKER 80' C/C UNLESS OTHERWISE INDICATED
- ▶ TWO-WAY AMBER MARKER 40' C/C UNLESS OTHERWISE INDICATED
- ▬ TRAFFIC SIGN

REVISIONS	
NAME	DATE

ILLINOIS DEPARTMENT OF TRANSPORTATION

**154TH STREET
STREET RESURFACING
STRIPING PLAN**

SCALE: VERT. NA
HORIZ. 1"=50'

DATE: 04-11-07

DRAWN BY: PS/RG
CHECKED BY: PKB

F. A. U. NO.	SECTION	COUNTY	TOTAL SHEETS	SHEET NO.
1607	07-00114-00-RS	COOK	016	010
STA.		TO STA.		
FED. ROAD DIST. NO.	KLING	FED. RD PROJECT		

CONTRACT #83940

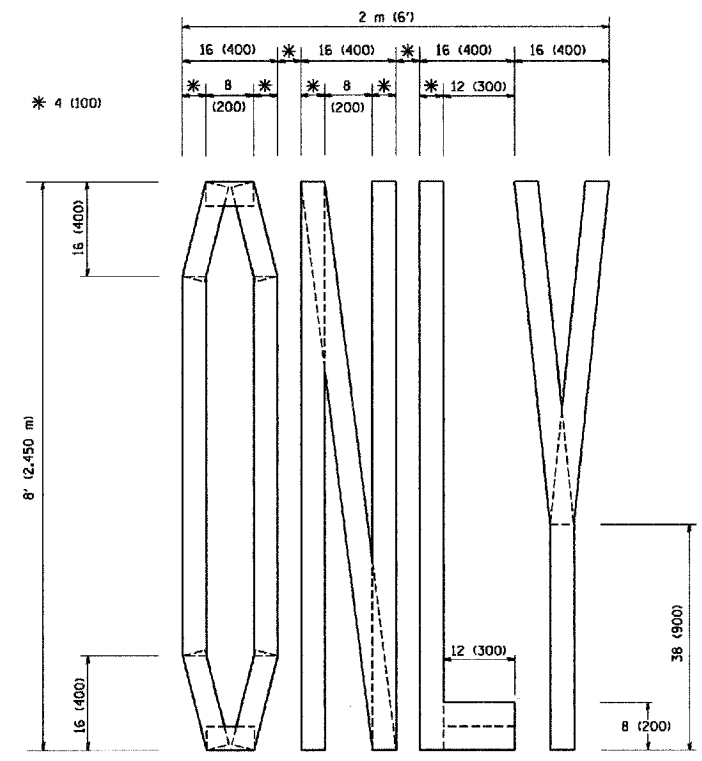

QUANTITY
4 (100) LINE = 64.1 ft. (19.7 m)
21.1 sq. ft. (1.97 sq. m)

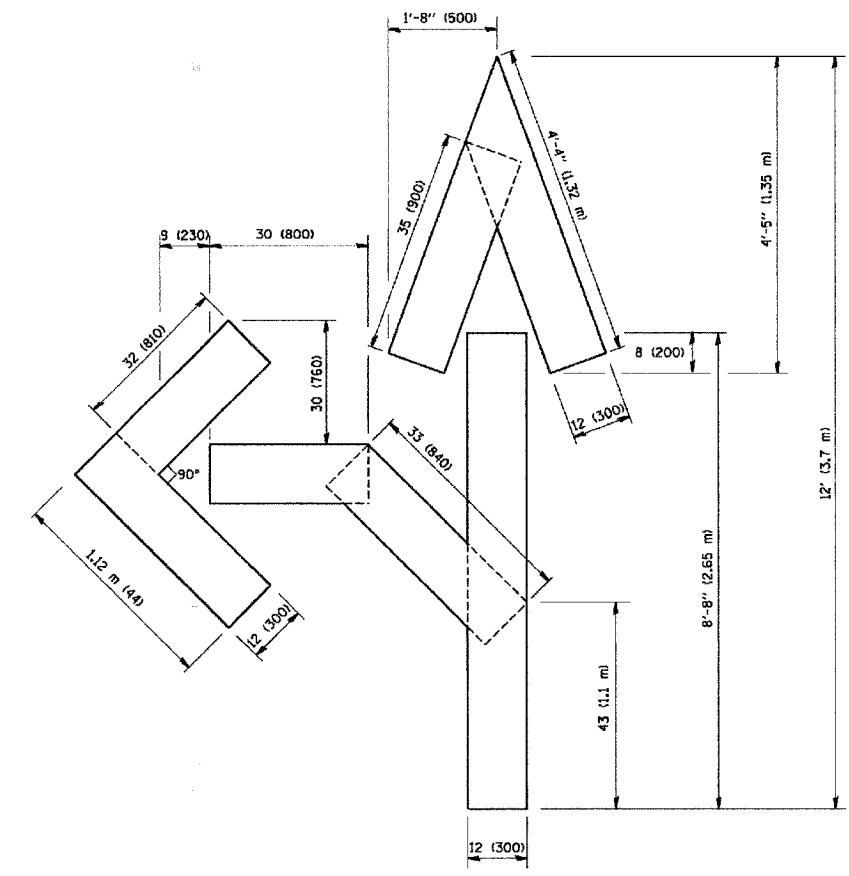

QUANTITY
4 (100) LINE = 82.5 ft. (25.3 m)
27.5 sq. ft. (2.53 sq. m)

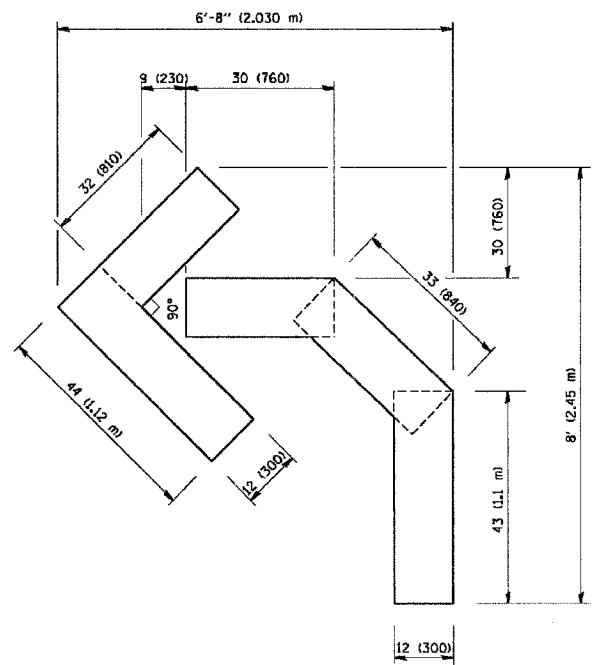

QUANTITY
4 (100) LINE = 45.5 ft. (13.9 m)
15.2 sq. ft. (1.39 sq. m)

All dimensions are in inches (millimeters) unless otherwise shown.

REVISIONS	
NAME	DATE
T. RAMMACHER	09/18/94
J. OBERLE	06/01/96
T. RAMMACHER	06/05/96
T. RAMMACHER	11/04/97
T. RAMMACHER	03/02/98
E. GOMEZ	08/28/00

ILLINOIS DEPARTMENT OF TRANSPORTATION

PAVEMENT MARKING
LETTERS AND SYMBOLS
FOR TRAFFIC STAGING

SCALE: NONE

DRAWN BY CADD
CHECKED BY
TC-16

F. A. U. NO.	SECTION	COUNTY	TOTAL SHEETS	SHEET NO.
1607	07-00083-00-RS	COOK	016	011
STA.	TO STA.			
FED. ROAD DIST. NO.	CLASS	FED. AID PROJECT		

CONTRACT #83940

LOOPS NEXT TO SHOULDERS

PROVIDE A PAVEMENT REPLACEMENT NOTE WHICH SHOULD EQUAL 3' (900 mm) X WIDTH OF PAVED SHOULDER.

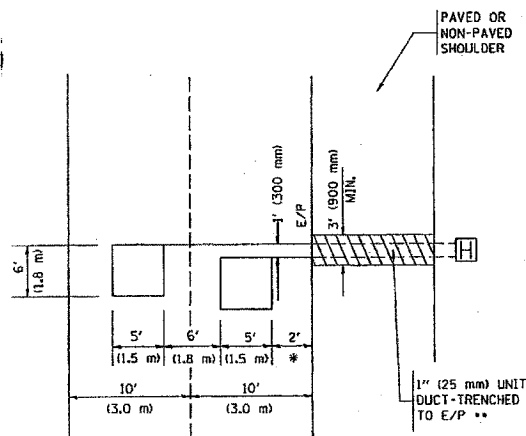

* = (600 mm)

** UNIT DUCT IS TO BE SHOWN ON PLAN SHEETS BUT SHALL NOT BE INCLUDED IN THE PAY ITEMS.

**LEFT TURN LANES WITH MEDIANS
VOLUME DENSITY ("FAR OUT" DETECTION)
ON SAME APPROACH
(PROTECTED / PERMITTED LEFT TURN PHASING)**

HANDHOLE LOCATION MAY VARY DEPENDING ON GEOMETRICS AND DESIGN OF TRAFFIC SIGNALS. HEAVY-DUTY HANDHOLES TO BE USED WHEN THE MEDIAN IS MOUNTABLE. REFER TO STANDARD 814001 TO ENSURE THAT HANDHOLE FITS IN MEDIAN.

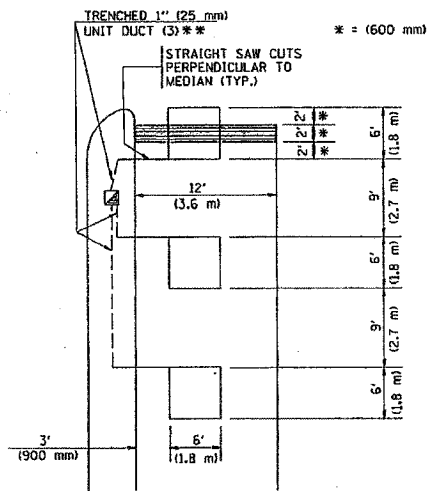

** UNIT DUCT IS TO BE SHOWN ON PLAN SHEETS BUT SHALL NOT BE INCLUDED IN THE PAY ITEMS.

NOTE: DUAL LEFT TURNS NOT SHOWN REFER TO PLAN SHEET FOR DETECTOR LOOP REPLACEMENT

**LEFT TURN LANES WITHOUT MEDIANS
VOLUME DENSITY ("FAR OUT" DETECTION)
ON SAME APPROACH
(PROTECTED / PERMITTED LEFT TURN PHASING)**

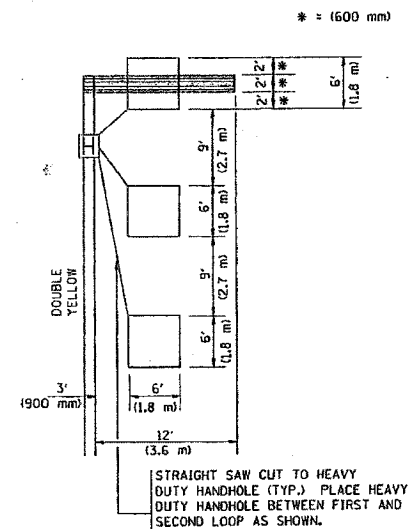

NOTE: DUAL LEFT TURNS NOT SHOWN REFER TO PLAN SHEET FOR DETECTOR LOOP REPLACEMENT

NOTES:

VEHICLES LOOP DETECTORS

- * ALL LEAD IN CABLE SHALL BE TWO CONDUCTOR NO. 14 TWISTED, SHIELDED.
- * EACH DETECTOR LOOP SHALL HAVE ITS OWN SAW CUT FROM THE LOOP TO THE EDGE OF PAVEMENT OR TO A HANDHOLE IN THE PAVEMENT.
- * EACH DETECTOR LOOP SHALL HAVE ITS OWN ONE INCH (25 mm) UNIT DUCT BETWEEN THE EDGE OF PAVEMENT AND THE FIRST HANDHOLE OR JUNCTION BOX. EACH UNIT DUCT RUN SHALL BE SHOWN ON THE PLANS BY THE DESIGNER, BUT SHALL NOT BE PAID FOR SEPARATELY. THIS ITEM IS INCIDENTAL TO THE PAY ITEM FOR DETECTOR LOOPS.
- * ONE DIMENSION OF ALL DETECTOR LOOPS SHALL BE SIX FEET (1.8 m)
- * EACH LANE OF NON-LOCKING, PRESENCE DETECTION AND EACH LANE OF A DOUBLE LEFT TURN LANE REQUIRES A SEPARATE INDUCTIVE LOOP DETECTOR AND LEAD IN CABLE.
- * WHEN NON-LOCKING, PRESENCE DETECTION IS USED, MORE THAN ONE LOOP PER LANE IS REQUIRED BEHIND THE STOP BAR (i.e. 1-1/2, 1-3/4, 2).
- * WHEN SYSTEM LOOPS ARE REQUIRED ON AN APPROACH OF AN INTERSECTION, THE LOOPS USED FOR VOLUME DENSITY AND INTERSECTION TIMING SHALL ALSO BE USED AS SYSTEM DETECTORS. EACH ONE OF THESE TYPE OF LOOPS REQUIRES A SEPARATE TWO CONDUCTOR NO. 14 TWISTED SHIELDED CABLE AND A SEPARATE INDUCTIVE LOOP DETECTOR WHEN NEW CONTROLLERS ARE UTILIZED. THE DESIGNER SHALL LABEL THESE TYPES OF LOOPS AS "INTERSECTION AND SAMPLING (SYSTEM) DETECTORS" ON THE SIGNAL LAYOUT, THE INTERCONNECT PLAN AND THE SYSTEM CABLE PLAN. WHEN AN EXISTING CONTROLLER IS UTILIZED FOR THIS TYPE OF DETECTION, THE PAY ITEM "INDUCTIVE LOOP DETECTOR WITH SYSTEM OUTPUT" SHOULD BE USED.

PLACEMENT OF DETECTORS

THE FOLLOWING FIGURES REPRESENT THE MOST COMMON DETECTOR LOOP LOCATIONS AND SIZES. ADJUSTMENTS WILL BE NECESSARY FOR SPECIFIC GEOMETRIC CONSIDERATIONS.

LOCATIONS AND DIMENSIONS OF DETECTOR LOOPS ARE REQUIRED ON ALL SIGNAL LAYOUT PLAN SHEETS.

"FAR OUT" DETECTION REFERS TO LOCKING, PRESENCE TYPE DETECTION LOCATED IN THRU LANES, RIGHT TURN LANES, AND RIGHT TURN LANE TAPER AREAS (IF APPLICABLE), USUALLY 250' (75 m) IN ADVANCE OF STOP BARS. "UPTIGHT" DETECTION REFERS TO NON-LOCKING PRESENCE TYPE DETECTION LOCATED IN ALL LANES AND 10'-15' (3.0 m-4.5 m) BEHIND THE CROSSING STREET'S EDGE OF PAVEMENT EXTENDED.

NOTE:

ALL DETAILS AND NOTES SHOWN ARE FROM THE I.D.O.T. DISTRICT 1 TRAFFIC SIGNAL DESIGN GUIDELINES DATED JANUARY 1995

THIS DRAWING HAS BEEN PREPARED TO ASSIST THE RESIDENT ENGINEER FOR ALL ROADWAY RESURFACING OR S.M.A.R.T. PROJECTS WHERE THE DIMENSIONS ARE NOT SHOWN ON THE PLANS AND THE FINAL LOCATIONS FOR CROSSWALKS OR STOP BARS ARE NOT DETERMINED.

**ARTERIAL-VOLUME DENSITY ("FAR OUT" DETECTION)
CROSS STREET-VOLUME DENSITY ("FAR OUT" DETECTION)**

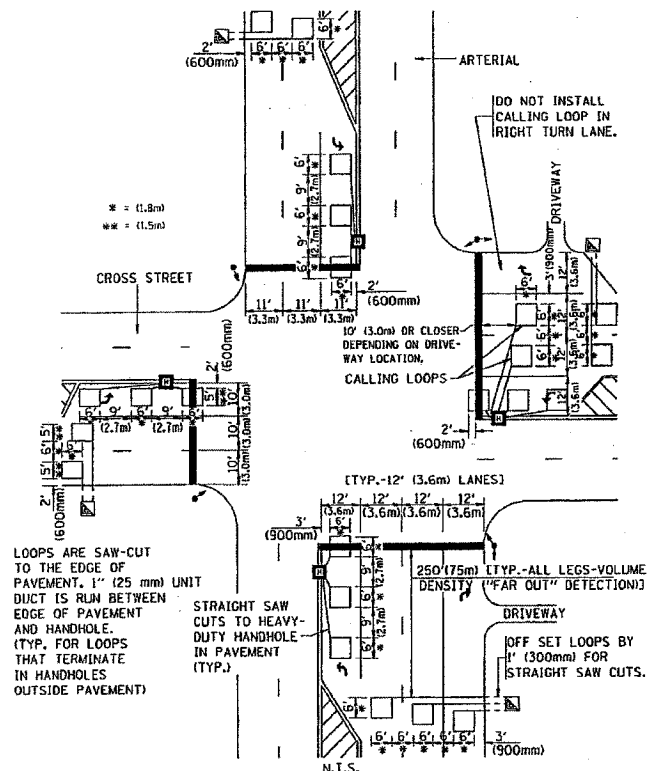

DETAIL 1
N.T.S.

**ARTERIAL-VOLUME DENSITY ("FAR OUT" DETECTION)
CROSS STREET-NON VOLUME DENSITY ("UPTIGHT" PRESENCE DETECTION)**

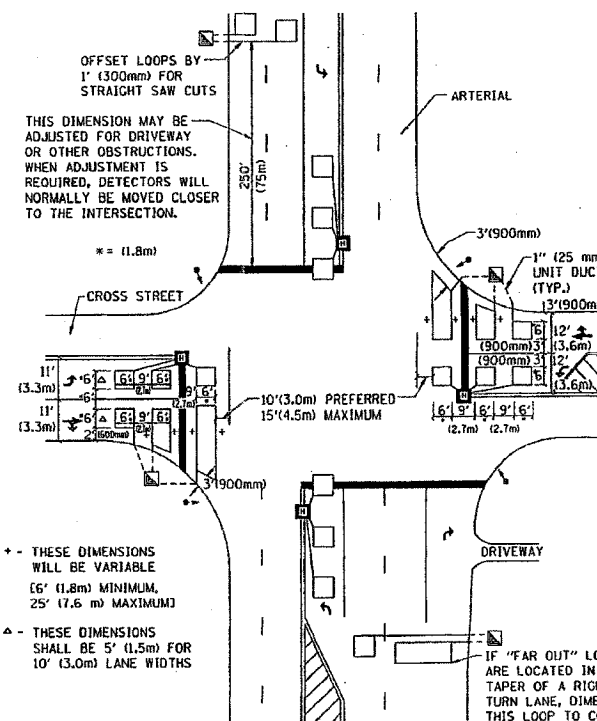

DETAIL 2
N.T.S.

REVISIONS	
NAME	DATE

ILLINOIS DEPARTMENT OF TRANSPORTATION
**DISTRICT 1
DETECTOR LOOP
INSTALLATION DETAILS
FOR ROADWAY RESURFACING**

SCALE: NONE
DATE: 10/18/2002

DRAWN BY CADD
DESIGNED BY
CHECKED BY R.K.F.
TSOT

REVISION DATE:

F. A. U. NO.	SECTION	COUNTY	TOTAL SHEETS	SHEET NO.
1607	07-00083-00-RS	COOK	016	012
STA.		TO STA.		
FED. ROAD DIST. NO.	CLASS	FED. AID PROJECT		

CONTRACT #83940

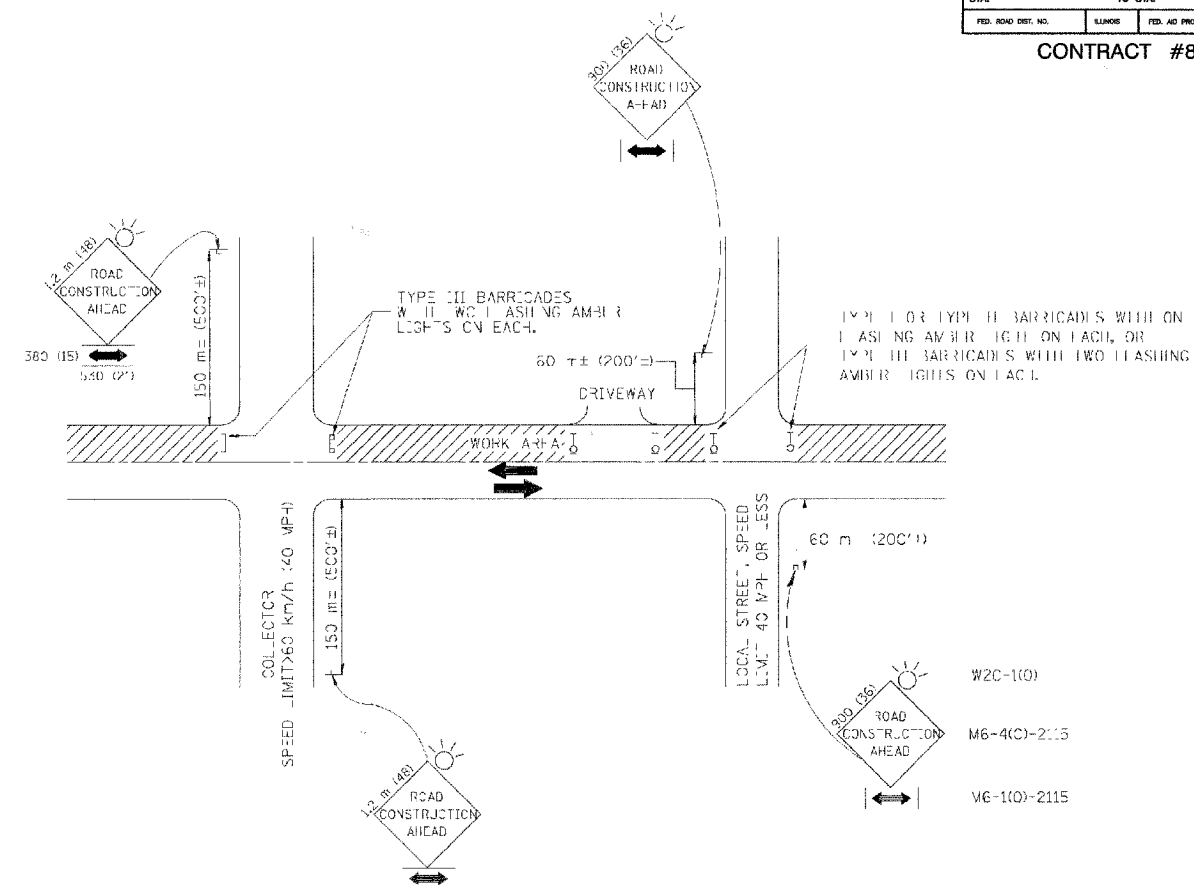

TRAFFIC CONTROL AND PROTECTION FOR SIDE ROADS, INTERSECTIONS, AND DRIVEWAYS

NOTES:

A. FOR NO LANE RESTRICTION ON THE SIDE ROAD OR DRIVEWAYS

- SIDE ROAD WITH A SPEED LIMIT OF 60 km/h (40 MPH) OR LESS AS SHOWN ON THE DRAWING AND AS DIRECTED BY THE ENGINEER:
 - ONE **ROAD CONSTRUCTION AHEAD** SIGN 900x900 (36x36) W. F. A. FLASHER AND FLAG MOUNTED ON IT APPROXIMATELY 60 m (200') IN ADVANCE OF THE MAIN ROUTE.
 - THE CLOSED PORTION OF THE MAIN ROUTE SHALL BE PROTECTED BY BLOCKING WITH TYPE I, TYPE II OR TYPE III BARRICADES, 1/3 OF THE CROSS SECTION OF THE CLOSED PORTION.
- SIDE ROAD WITH A SPEED LIMIT GREATER THAN 60 km/h (40 MPH) AS SHOWN ON THE DRAWING AND AS DIRECTED BY THE ENGINEER:
 - ONE **ROAD CONSTRUCTION AHEAD** SIGN 1.2 m x 1.2 m (48x48) W. F. A. FLASHER MOUNTED ON IT APPROXIMATELY 150 m (500') IN ADVANCE OF THE MAIN ROUTE.
 - THE CLOSED PORTION OF THE MAIN ROUTE SHALL BE PROTECTED BY BLOCKING WITH TYPE III BARRICADES, 1/2 OF THE CROSS SECTION OF THE CLOSED PORTION.
- WHEN THE SIDE ROAD LIES BETWEEN THE BEGINNING OF THE MAINLINE SIGNING AND THE WORK ZONE, A SIGN HEADED ARROW (M6-1) SHALL BE USED IN lieu OF THE DOUBLE HEADED ARROW (M6-4).

B. FOR A LANE CLOSURE ON A SIDE ROAD OR DRIVEWAY:

USE APPLICABLE PORTIONS OF THE TYPICAL APPLICATION OF TRAFFIC CONTROL DEVICES (STD. 70150L, STD. 70160R OR THE APPROPRIATE STANDARD). THE SPACING OF SIGNS AND BARRICADES SHALL BE ADJUSTED FOR FIELD CONDITIONS AS DIRECTED BY THE ENGINEER. THE DIRECTIONAL ARROW SHALL BE COVERED OR REMOVED WHEN NO LONGER CONSISTENT WITH THE SIDE ROAD LANE CLOSURE.

C. ADVANCE WARNING SIGNS ARE TO BE OMITTED ON DRIVEWAY UNLESS OTHERWISE NOTED.

D. THE TRAFFIC CONTROL AND PROTECTION FOR SIDE ROADS, INTERSECTIONS, AND DRIVEWAYS SHALL BE INCIDENTAL TO THE COST OF SPECIFIED TRAFFIC CONTROL STANDARDS OR ITEMS.

REVISIONS	
NAME	DATE
T. RAYMACHER	05/08/94
J. OBERLE	10/18/95
A. HOUSEH	03/06/96
A. HOUSEH	10/15/96
T. RAYMACHER	01/06/00

ILLINOIS DEPARTMENT OF TRANSPORTATION
 TRAFFIC CONTROL AND PROTECTION
 FOR
 SIDE ROADS, INTERSECTIONS, AND
 DRIVEWAYS

SCALE: V=H
 HORIZ.
 DATE: 10/7/8/2002

DRAWN BY
 CHECKED BY

TC IC

REVISION DATE: 01/05/00

F. A. U. NO.	SECTION	COUNTY	TOTAL SHEETS	SHEET NO.
1607	07-00083-00-RS	COOK	016	013
STA.	TO STA.			
FED. ROAD DIST. NO.	LANDS	FED. RD PROJECT		

CONTRACT #83940

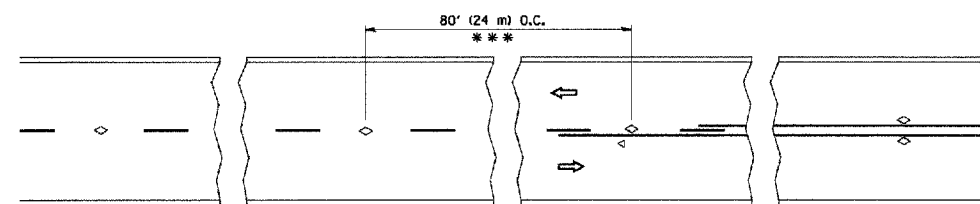

*** REDUCE TO 40' (12 m) O.C. ON CURVES WITH POSTED OR ADVISORY SPEED 45 M.P.H. (70 km/h) OR LESS.

TWO-LANE/TWO-WAY

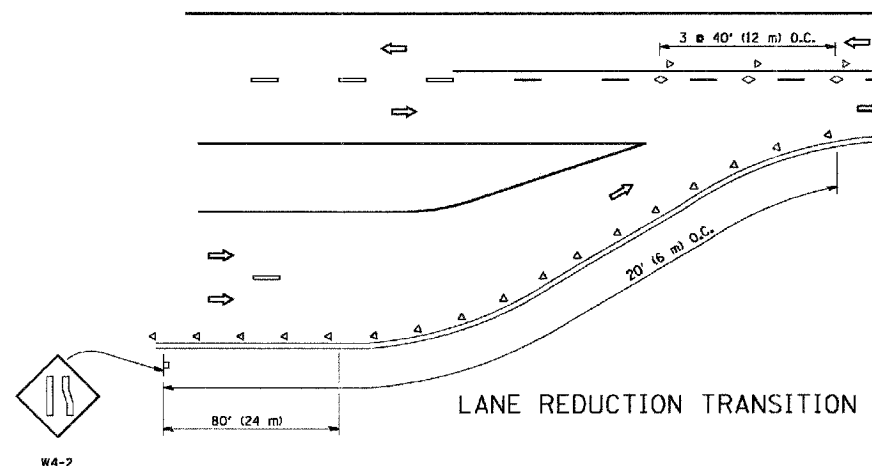

LANE REDUCTION TRANSITION

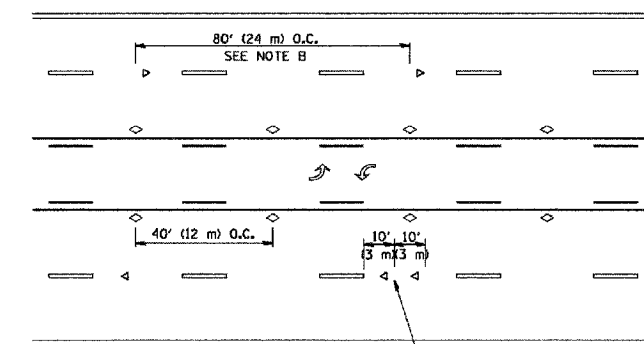

TWO-WAY LEFT TURN

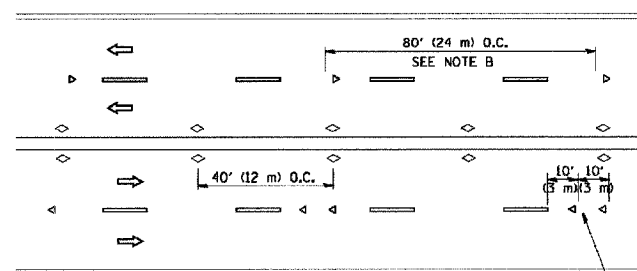

MULTI-LANE/UNDIVIDED

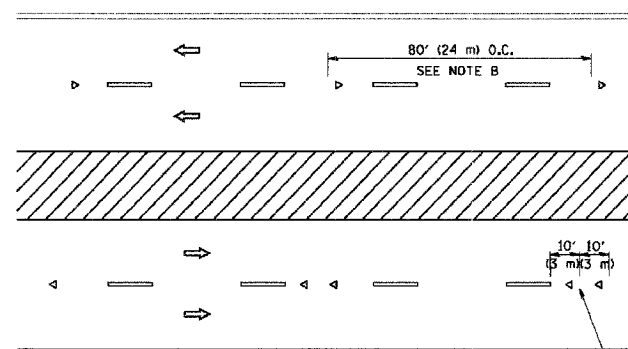

MULTI-LANE/DIVIDED

GENERAL NOTES

1. MARKERS USED WITH DASHED LINES SHALL BE CENTERED IN THE GAP BETWEEN SEGMENTS.
2. MARKERS USED ADJACENT TO SOLID LINES SHALL BE OFFSET 2 TO 3 (50 TO 75) TOWARD TRAFFIC AS SHOWN.
3. MARKERS THROUGH TANGENTS LESS THAN 500' (150 m) IN LENGTH BETWEEN CURVES SHALL BE INSTALLED AT THE LESSER OF THE TWO CURVE SPACINGS.

SYMBOLS

- YELLOW STRIPE
- WHITE STRIPE
- ◁ ONE-WAY AMBER MARKER
- ◁ ONE-WAY CRYSTAL MARKER (W/O)
- ◇ TWO-WAY AMBER MARKER

LANE MARKER NOTES

- B. REDUCE TO 40' (12 m) O.C. ON CURVES WHERE ADVISORY SPEEDS ARE 10 M.P.H. (20 km/h) LOWER THAN POSTED SPEEDS.
- A. USE DOUBLE LANE LINE MARKERS SPACED AS SHOWN.

DESIGN NOTES

1. DOUBLE LANE LINE MARKERS SHALL BE USED UNLESS SPECIFIED OTHERWISE.
2. EXCEPT AS SHOWN ON THE LANE REDUCTION TRANSITION AND FREEWAY EXIT RAMP DETAIL, MARKERS ARE NOT TO BE SPECIFIED ON RIGHT EDGE LINES.
3. THE EXACT MARKER LIMITS, SPACING, AND COLOR SHOULD BE INCLUDED IN THE PLANS.
4. MARKERS SHOULD NOT BE USED ALONGSIDE CURBS EXCEPT FOR EXTREMELY SHORT SECTIONS OF CURBS WHERE NOT MORE THAN TWO MARKERS WOULD BE INVOLVED.

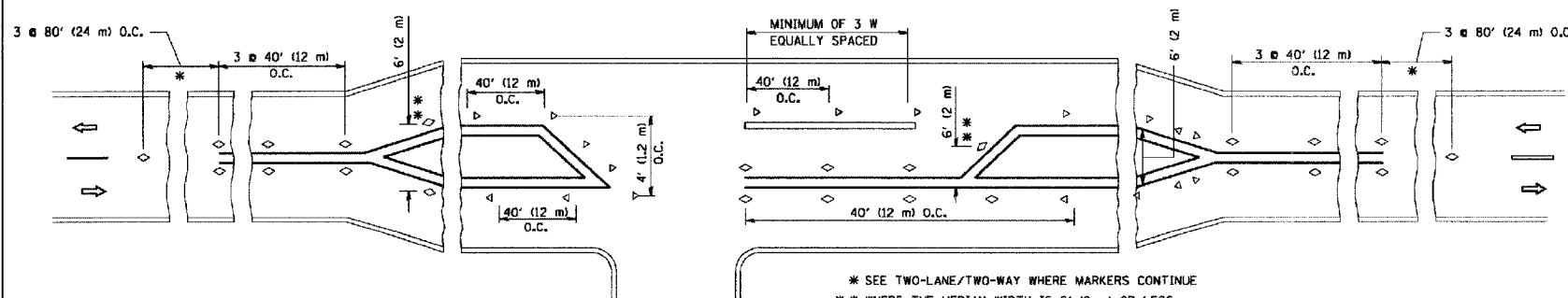

LEFT TURN

* SEE TWO-LANE/TWO-WAY WHERE MARKERS CONTINUE
 ** WHERE THE MEDIAN WIDTH IS 6' (2 m) OR LESS USE TWO-WAY MARKERS.

All dimensions are in inches (millimeters) unless otherwise shown.

REVISIONS	
NAME	DATE
T. RAMMACHER	09-19-94
T. RAMMACHER	03-12-99
T. RAMMACHER	01-06-00

ILLINOIS DEPARTMENT OF TRANSPORTATION
 TYPICAL APPLICATIONS
 RAISED REFLECTIVE PAVEMENT
 MARKERS (SNOW-PLOW RESISTANT)

SCALE: NONE

DRAWN BY CADD
 CHECKED BY
 TC-11

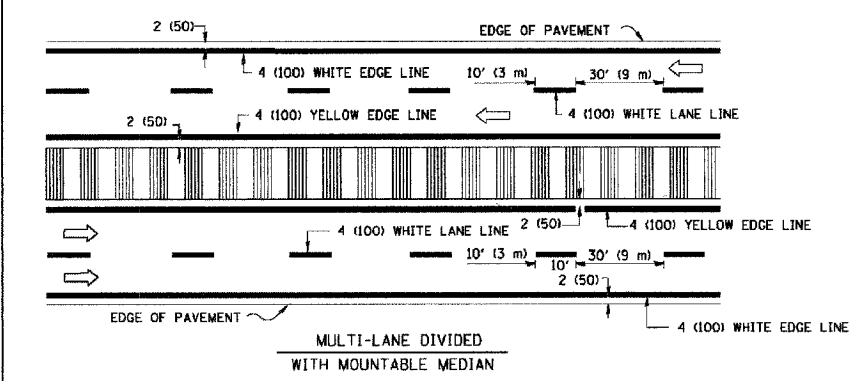
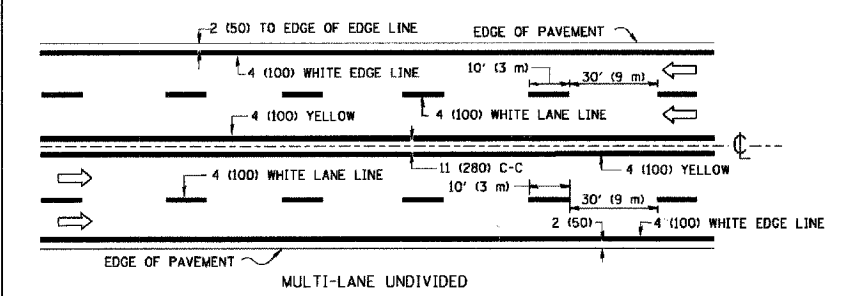
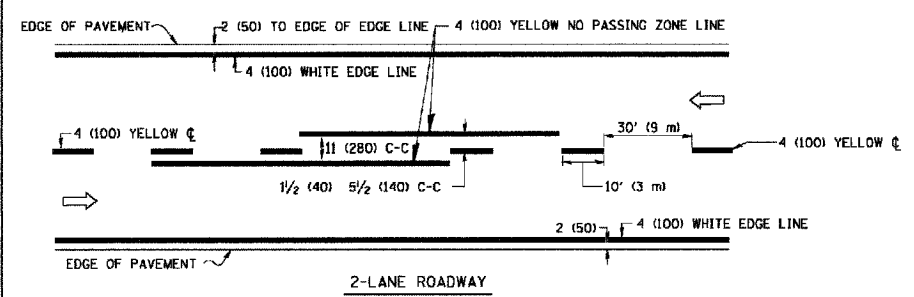

NOTE: MEDIANS WITH BARRIER CURB DO NOT REQUIRE AN EDGE LINE

TYPICAL LANE AND EDGE LINE MARKING

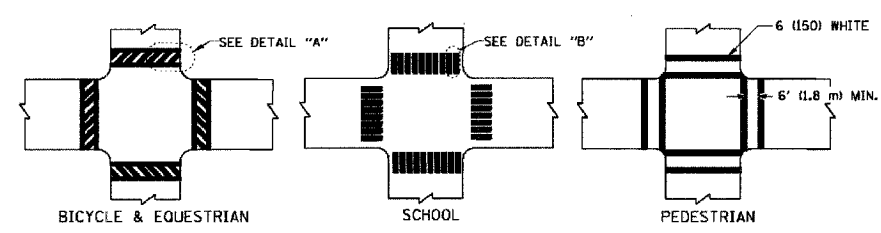

TYPICAL CROSSWALK MARKING

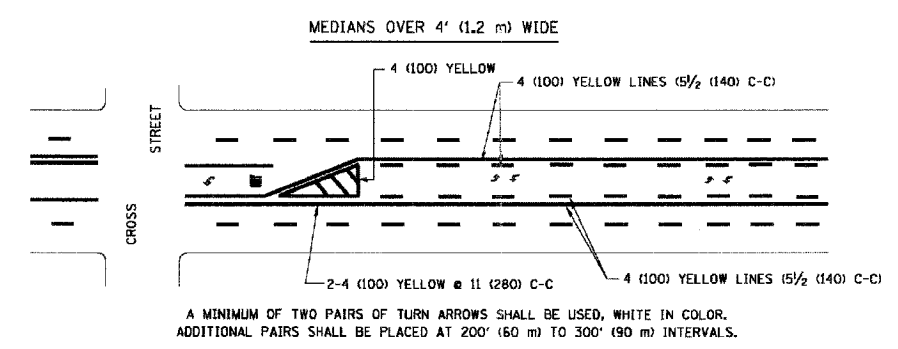
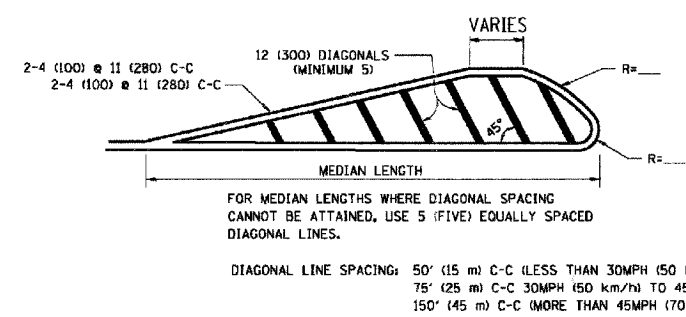
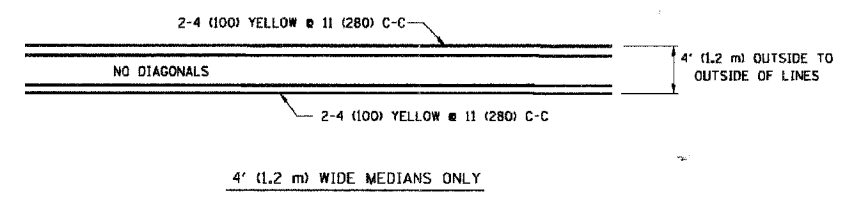
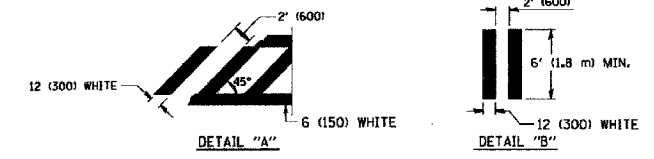

TYPICAL PAINTED MEDIAN MARKING

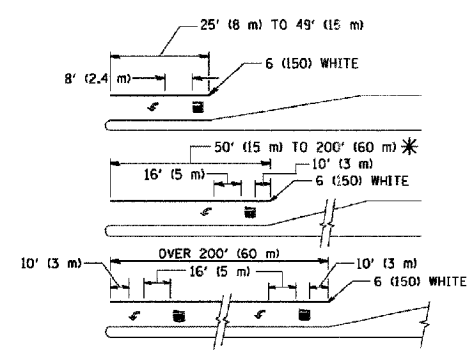

FULL SIZE LETTERS 8' (2.4 m) AND ARROWS SHALL BE USED.
AREA = 15.6 SQ. FT. (1.5 m²) | AREA = 20.8 SQ. FT. (1.9 m²)

* TURN LANES IN EXCESS OF 400' (120 m) IN LENGTH MAY HAVE AN ADDITIONAL SET OF ARROW - "ONLY" INSTALLED MIDWAY BETWEEN THE OTHER TWO SETS OF ARROW - "ONLY".

TYPICAL LEFT (OR RIGHT) TURN LANE MARKING

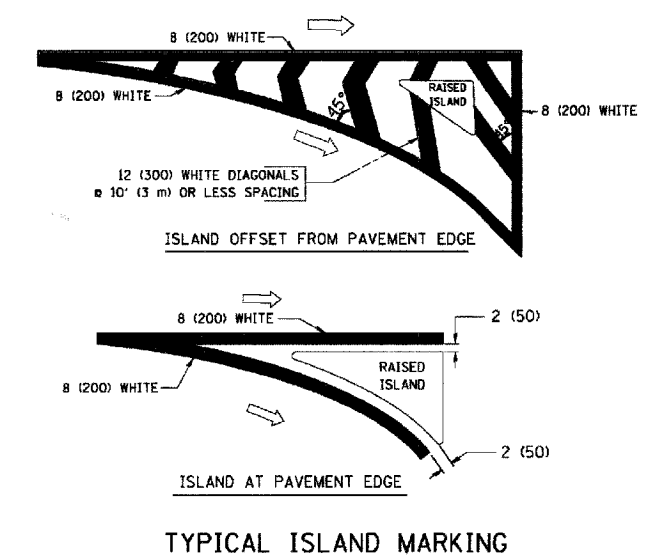

TYPE OF MARKING	WIDTH OF LINE	PATTERN	COLOR	SPACING / REMARKS
CENTERLINE ON 2 LANE PAVEMENT	4 (100)	SKIP-DASH	YELLOW	10' (3 m) LINE WITH 30' (9 m) SPACE
CENTERLINE ON MULTI-LANE UNDIVIDED PAVEMENT	2 & 4 (100)	SOLID	YELLOW	11 (280) C-C
NO PASSING ZONE LINES FOR ONE DIRECTION FOR BOTH DIRECTIONS	4 (100) 2 & 4 (100)	SOLID SOLID	YELLOW YELLOW	5/2 (140) C-C FROM SKIP-DASH CENTERLINE 11 (280) C-C OMIT SKIP-DASH CENTERLINE BETWEEN
LANE LINES	4 (100) 5 (125) ON FREEWAYS	SKIP-DASH SKIP-DASH	WHITE WHITE	10' (3 m) LINE WITH 30' (9 m) SPACE
DOTTED LINES (EXTENSIONS OF CENTER, LANE OR TURN LANE MARKINGS)	SAME AS LINE BEING EXTENDED	SKIP-DASH	SAME AS LINE BEING EXTENDED	2' (600) LINE WITH 6' (1.8 m) SPACE
EDGE LINES	4 (100)	SOLID	YELLOW-LEFT WHITE-RIGHT	OUTLINE MOUNTABLE MEDIANS IN YELLOW; EDGE LINES ARE NOT USED NEXT TO BARRIER CURB
TURN LANE MARKINGS	6 (150) LINE; FULL SIZE LETTERS & SYMBOLS (8' (2.4m))	SOLID	WHITE	SEE TYPICAL TURN LANE MARKING DETAIL
TWO WAY LEFT TURN MARKING	2 & 4 (100) EACH DIRECTION 8' (2.4m) LEFT ARROW	SKIP-DASH AND SOLID IN PAIRS	YELLOW WHITE	10' (3 m) LINE WITH 30' (9 m) SPACE FOR SKIP-DASH; 5/2 (140) C-C BETWEEN SOLID LINE AND SKIP-DASH LINE SEE TYPICAL TWO-WAY LEFT TURN MARKING DETAIL
CROSSWALK LINES (PEDESTRIAN) A. DIAGONALS (BIKE & EQUESTRIAN) B. LONGITUDINAL BARS (SCHOOL)	2 & 6 (150) 12 (3000) @ 45° 12 (3000) @ 90°	SOLID SOLID SOLID	WHITE WHITE WHITE	NOT LESS THAN 6' (1.8 m) APART 2' (600) APART 2' (600) APART SEE TYPICAL CROSSWALK MARKING DETAILS.
STOP LINES	24 (600)	SOLID	WHITE	PLACE 4' (1.2 m) IN ADVANCE OF AND PARALLEL TO CROSSWALK IF PRESENT. OTHERWISE, PLACE AT DESIRED STOPPING POINT. PARALLEL TO CROSSROAD CENTERLINE, WHERE POSSIBLE
PAINTED MEDIANS	2 & 4 (100) WITH 12 (3000) DIAGONALS @ 45° NO DIAGONALS USED FOR 4' (1.2 m) WIDE MEDIANS	SOLID	YELLOW; TWO WAY TRAFFIC WHITE; ONE WAY TRAFFIC	11 (280) C-C FOR THE DOUBLE LINE SEE TYPICAL PAINTED MEDIAN MARKING.
GORE MARKING AND CHANNELIZING LINES	8 (200) WITH 12 (3000) DIAGONALS @ 45°	SOLID	WHITE	DIAGONALS: 15' (4.5 m) C-C (LESS THAN 30MPH (50 km/h)) 20' (6 m) C-C 30MPH (50 km/h) TO 45MPH (70 km/h) 30' (9 m) C-C (OVER 45MPH (70 km/h))
RAILROAD CROSSING	24 (600) TRANSVERSE LINES; "RR" (5 6' (1.8 m) LETTERS; 16 (400) LINE FOR "X"	SOLID	WHITE	SEE STATE STANDARD 780001 AREA OF: "R"=3.6 SQ. FT. (0.33 m ²) EACH "X"=54.0 SQ. FT. (5.0 m ²)
SHOULDER DIAGONALS	12 (3000) @ 45°	SOLID	WHITE - RIGHT YELLOW - LEFT	50' (15 m) C-C (LESS THAN 30MPH (50 km/h)) 75' (25 m) C-C (30 MPH (50 km/h) TO 45MPH (70 km/h)) 150' (45 m) C-C (OVER 45MPH (70 km/h))

FOR FURTHER DETAILS ON PAVEMENT MARKING REFER TO STANDARD SPECIFICATIONS FOR ROAD AND BRIDGE CONSTRUCTION AND STATE STANDARD 780001.

All dimensions are in inches (millimeters) unless otherwise shown.

REVISIONS	
NAME	DATE
EVERS	03-19-90
T. RAMMACHER	10-27-94
ALEX HOUSEH	10-09-96
ALEX HOUSEH	10-17-96
T. RAMMACHER	01-06-00

ILLINOIS DEPARTMENT OF TRANSPORTATION
**DISTRICT ONE
TYPICAL PAVEMENT
MARKINGS**

SCALE: NONE
DRAWN BY CADD
CHECKED BY
TC-13

F. A. I. I. NO.	SECTION	COUNTY	TOTAL SHEETS	SHEET NO.
1607	07-00114-00-RS 07-00083-00-RS	COOK	016	015
STA.	TO STA.			
FED. ROAD DIST. NO.	BLANK	FED. AID PROJECT		

CONTRACT #83940

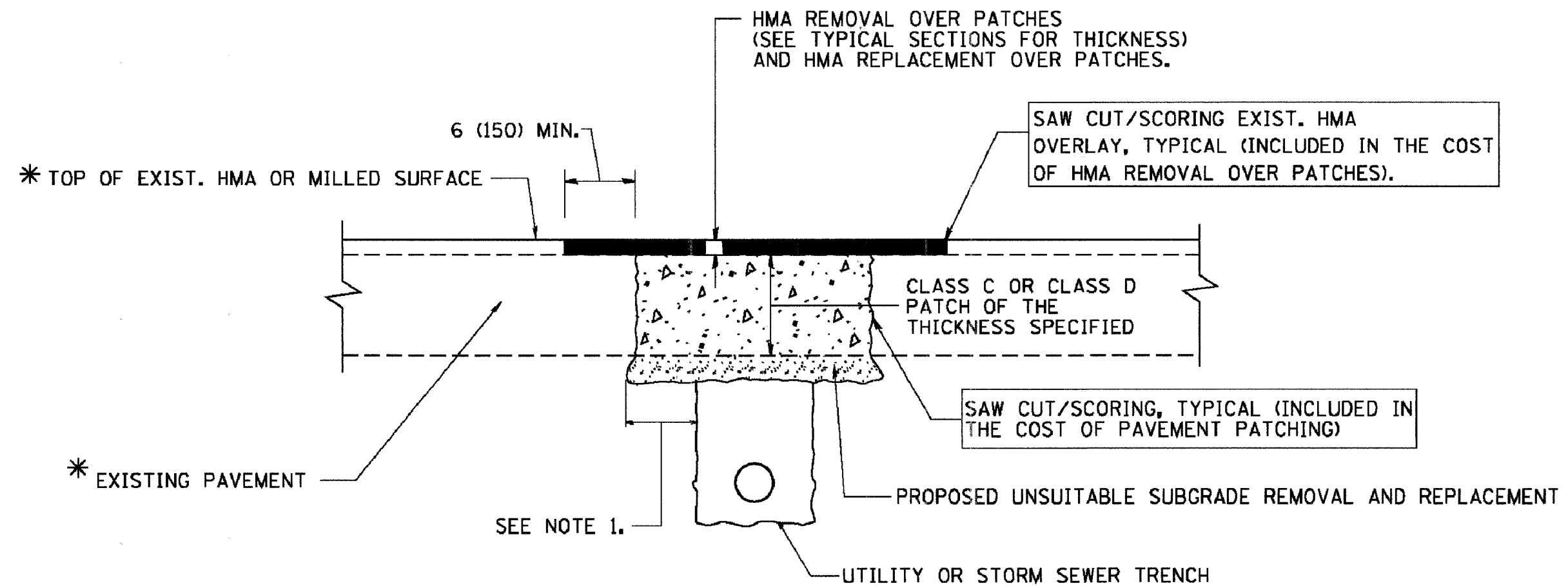

* SEE TYPICAL SECTIONS FOR THICKNESS AND MATERIALS

NOTES:

1. THE WIDTH OF THE FULL DEPTH PATCH OVER A TRENCH SHALL BE 12 (300) WIDER ON EACH SIDE OF THE TRENCH.
2. FOR METHOD OF MEASUREMENT AND BASIS OF PAYMENT, SEE RECURRING SPECIAL PROVISION "PATCHING WITH HOT-MIX ASPHALT OVERLAY REMOVAL".

SEQUENCE OF CONSTRUCTION

1. REMOVE THE EXISTING HMA MATERIAL OVER THE AREA TO BE PATCHED.
2. REMOVE AND REPLACE FULL DEPTH PATCHES
3. REPLACE HMA MATERIAL OVER THE AREA TO BE PATCHED.

ALL DIMENSIONS ARE IN INCHES (MILLIMETERS) UNLESS OTHERWISE SHOWN.

REVISIONS	DATE
R. SHAH	10/25/94
R. SHAH	01/14/95
R. SHAH	03/23/95
R. SHAH	04/24/95
A. HOUSEH	03/19/96
A. ABBAS	03/21/97
A. ABBAS	01/20/98
ART ABBAS	04/27/98
R. BORO	01/01/07

ILLINOIS DEPARTMENT OF TRANSPORTATION
PAVEMENT PATCHING FOR HMA SURFACED PAVEMENT

SCALE: VERT. NONE
HORIZ. 1/8"=1'-0"
PLOT DATE: 1/19/2007

DRAWN BY
CHECKED BY

BD400-04 (8D-22)
REVISION DATE: 01/01/07

F. A. U. NO.	SECTION	COUNTY	TOTAL SHEETS	SHEET NO.
1607	07-00083-00-RS	COOK	016	016
STA.	TO STA.			
FED. ROAD DIST. NO.	BLADE	FED. AID PROJECT		

CONTRACT #83940

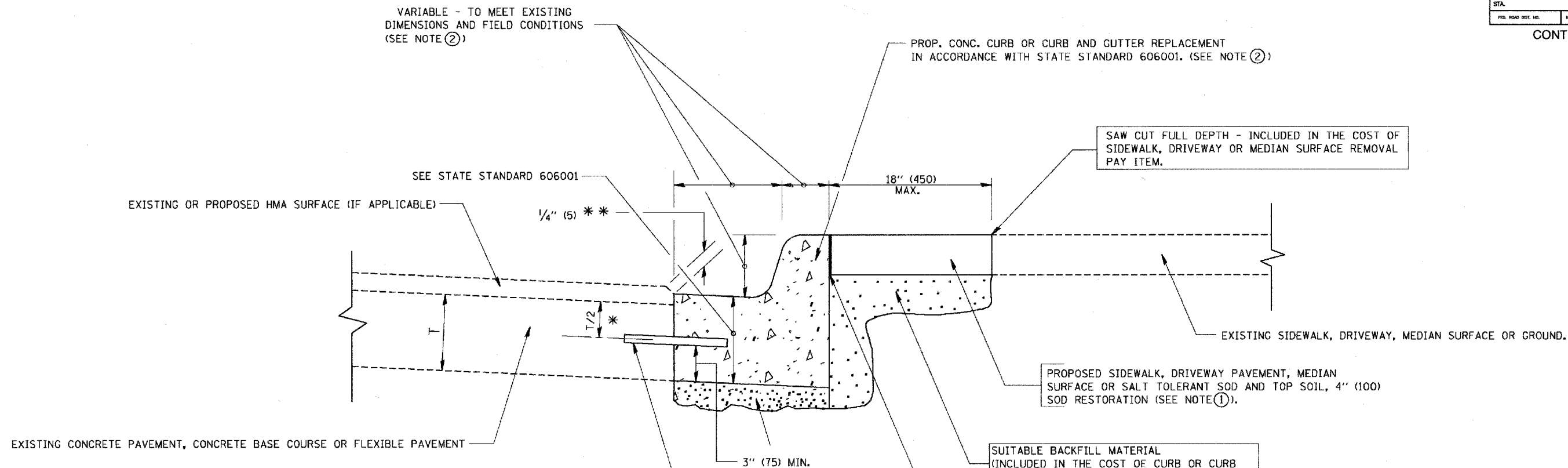

- * 3" (75) MINIMUM FROM TOP AND BOTTOM OF THE CONCRETE PAVEMENT OR BASE COURSE.
- * * IF THE FINAL SURFACE OF THE PAVEMENT IS CONCRETE, THE GUTTER IS TO BE FLUSH WITH THE PAVEMENT.

NOTE: ① SIDEWALK, DRIVEWAY PAVEMENT OR MEDIAN SURFACE SHALL BE SIMILAR TO THE MATERIAL BEING REMOVED AND WILL BE PAID FOR SEPARATELY.

SALT TOLERANT SOD AND TOP SOIL, 4" (100) RESTORATION WILL NOT BE PAID FOR SEPARATELY, BUT SHALL BE INCLUDED IN THE COST OF CURB OR CURB AND GUTTER REMOVAL AND REPLACEMENT.

- ② CURB OR CURB AND GUTTER REPLACEMENT SHALL MATCH THE SHAPE OF THE EXISTING CURB OR CURB AND GUTTER UNLESS OTHERWISE SPECIFIED.
- ③ FOR CURB OR CURB AND GUTTER REMOVAL AND REPLACEMENT ADJACENT TO FLEXIBLE PAVEMENT DELETE EPOXY COATED TIE BARS.

④ LONGITUDINAL BARS, IF ENCOUNTERED IN THE EXISTING CURB OR CURB AND GUTTER, ARE NOT TO BE REPLACED. CUTTING AND REMOVING LONGITUDINAL BARS SHALL BE INCLUDED IN THE COST OF CURB OR CURB AND GUTTER REMOVAL AND REPLACEMENT.

⑤ THE COST OF HMA SURFACE REMOVAL IN THE EXISTING GUTTER FLAG SHALL BE INCLUDED IN THE COST OF THE CURB AND GUTTER REMOVAL AND REPLACEMENT.

⑥ THE REMOVAL AND REPLACEMENT OF THE EXISTING CURB OR CURB AND GUTTER SHALL BE DONE IN ACCORDANCE WITH THE APPLICABLE PORTIONS OF SECTION 440 AND 606 OF THE STANDARD SPECIFICATIONS.

⑦ THE LOCATIONS OF REMOVAL AND REPLACEMENT OF EXISTING CURB OR CURB AND GUTTER SHALL BE DETERMINED BY THE RESIDENT ENGINEER AT THE TIME OF CONSTRUCTION.

UNSUITABLE SUB-BASE MATERIAL TO BE REMOVED, IF DIRECTED BY THE ENGINEER, SHALL BE REPLACED WITH EITHER SUB-BASE GRANULAR MATERIAL, TYPE B OR ADDITIONAL THICKNESS OF CONCRETE.

REMOVAL AND REPLACEMENT 4" (100) OR LESS IS INCLUDED IN THE COST OF CURB OR CURB AND GUTTER REMOVAL AND REPLACEMENT.

REMOVAL AND REPLACEMENT IN EXCESS OF 4" (100) WILL BE PAID FOR IN ACCORDANCE WITH ARTICLE 109.04 OF THE STANDARD SPECIFICATIONS.

PROPOSED #6 (20) EPOXY COATED TIE BARS 24" (600) LONG AT 24" (600) CENTERS WILL NOT BE PAID FOR SEPARATELY. DELETE EPOXY COATED TIE BARS IF EXISTING TIE BARS ARE USABLE AS DETERMINED BY THE ENGINEER. (SEE NOTE ③).

BASIS OF PAYMENT:

THIS WORK WILL BE PAID FOR AT THE CONTRACT UNIT PRICE PER FOOT (METER) FOR "CURB REMOVAL AND REPLACEMENT" OR "COMBINATION CONCRETE CURB AND GUTTER REMOVAL AND REPLACEMENT".

ALL DIMENSIONS ARE IN INCHES (MILLIMETERS) UNLESS OTHERWISE SHOWN.

CURB OR CURB AND GUTTER REMOVAL AND REPLACEMENT

REVISIONS	
NAME	DATE
A. HOUSEH	03/11/94
R. SHAH	02/24/95
R. SHAH	03/02/95
R. SHAH	08/19/96
R. SHAH	09/12/96
R. SHAH	09/19/96
R. SHAH	10/03/96
A. ABBAS	03/21/97
M. GOMEZ	01/22/01
R. BORO	01/01/07

ILLINOIS DEPARTMENT OF TRANSPORTATION

CURB OR CURB AND GUTTER REMOVAL AND REPLACEMENT

SCALE: VERT. NONE
HORIZ.

DRAWN BY
CHECKED BY

BD600-06 (BD-24)