

LINTEL SCHEDULE				
NO.	SIZE	SHAPE	M.O.	BRG. LENGTH (EACH END)
L-1	2- $\angle 3/2 \times 3/2 \times 3/8$	L	6'-8"	8"

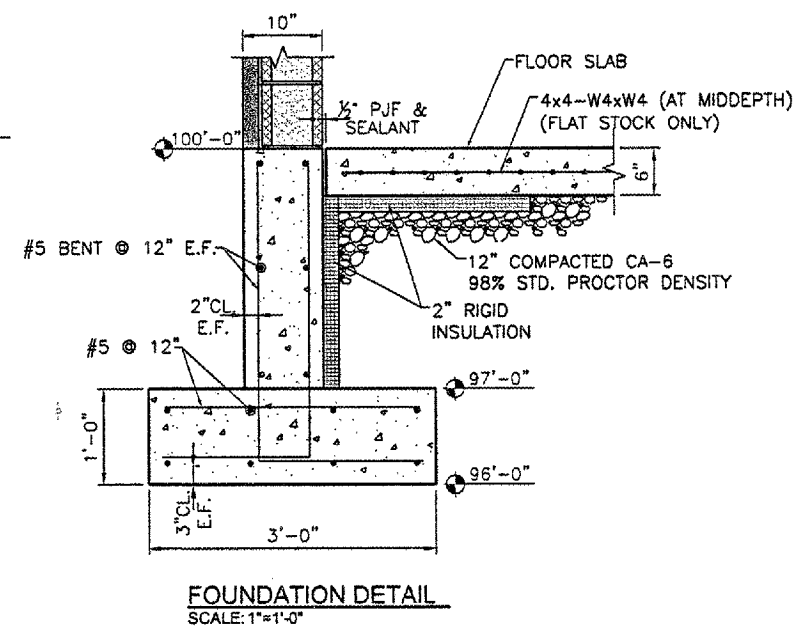
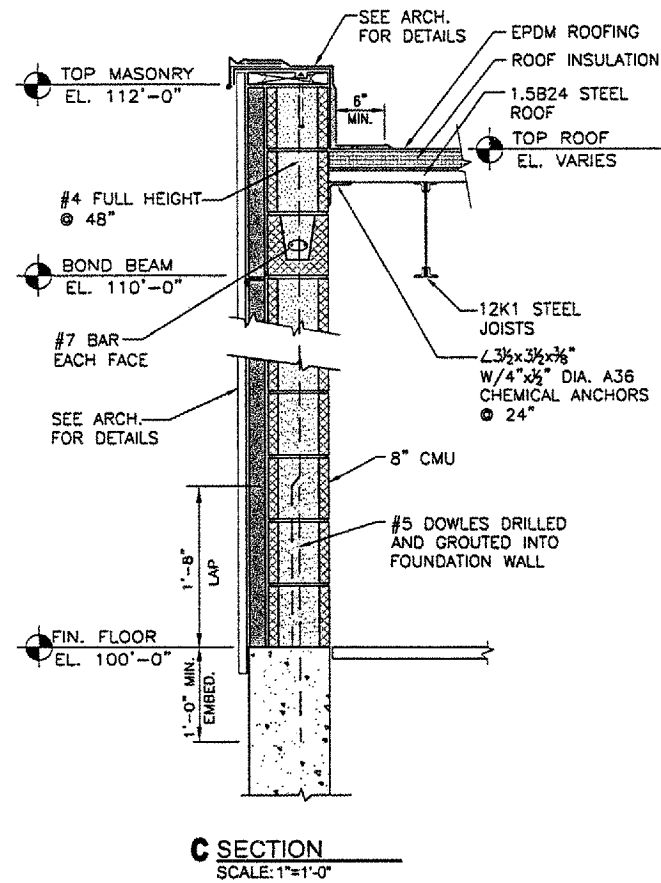
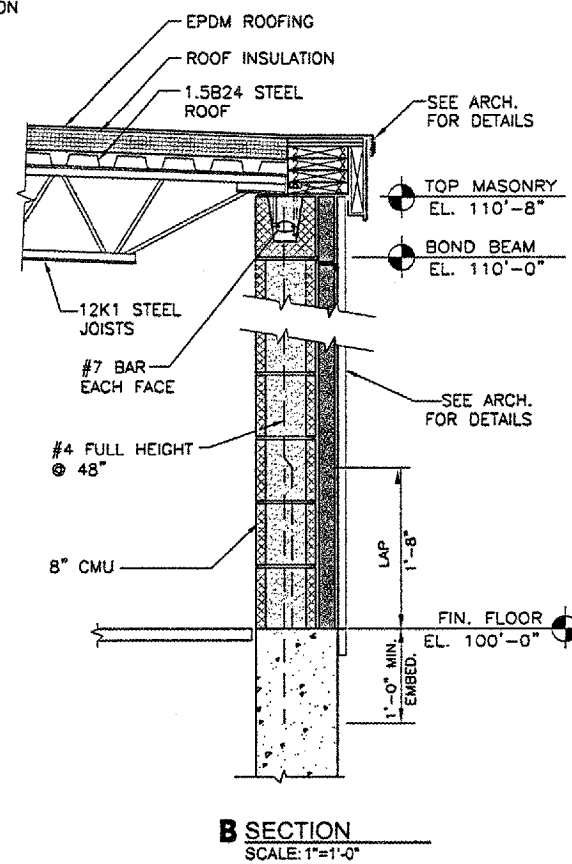
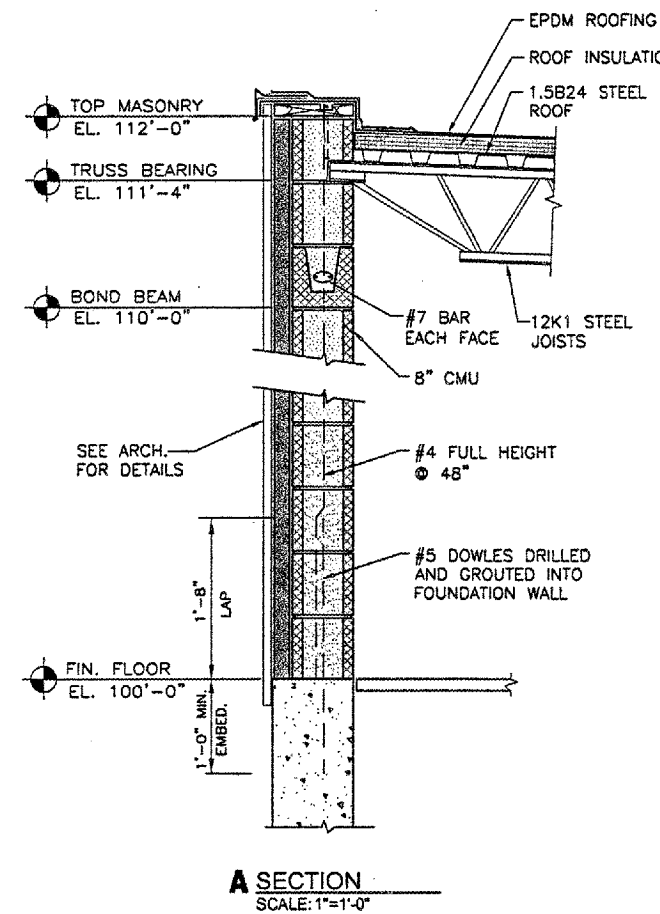

- NOTES**
- LOOSE LINTELS NOT SHOWN ON THESE DRAWINGS SHALL BE PROVIDED IN ACCORDANCE WITH SPECIFICATION SECTION 05500.
 - STEEL DECK SHALL BE FASTENED TO SUPPORTING MEMBERS IN ACCORDANCE WITH SPECIFICATION SECTION 05311.

REVISIONS

NUMBER	BY	DATE

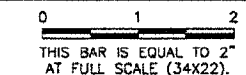

VERMILION COUNTY AIRPORT
 DANVILLE, ILLINOIS

RELOCATE AIRFIELD ELECTRICAL VAULT
 NEW ELECTRICAL VAULT
 STRUCTURAL DETAILS

© Copyright CMT, Inc.

CMT
 CRANFORD, MURPHY & TULLY, INC.
 CONSULTING ENGINEERS
 License No. 004-000615

DESIGN BY:	JEL
DRAWN BY:	KM
CHECKED BY:	JJF
APPROVED BY:	CET
DATE:	06-22-2007
JOB No:	0704202
ILLINOIS PROJECT DNV-3684	
A.I.P. PROJECT 3-17-0032-B11	
SHEET 15 OF 18 SHEETS	