

F.A.I.	SECTION	COUNTY	TOTAL SHEETS	SHEET NO.
94/90	*	COOK	588	26
STA.	TO STA.			
FED. ROAD DIST. NO.	ILLINOIS	FED. AID PROJECT		
62303 • (2021-922 PT2 ETC 2324.6-1P) R-11				

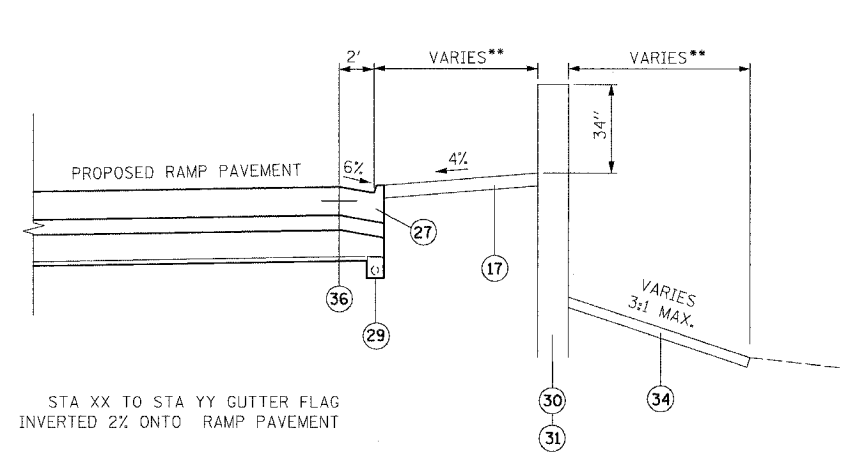

**PROPOSED TYPICAL INSIDE RAMP SHOULDER
TREATMENT WITH RETAINING WALL**

STATION	RAMP
5066+13.30 TO 5070+72.56	- 47A
54+79.84 TO 7044+17	- 39D

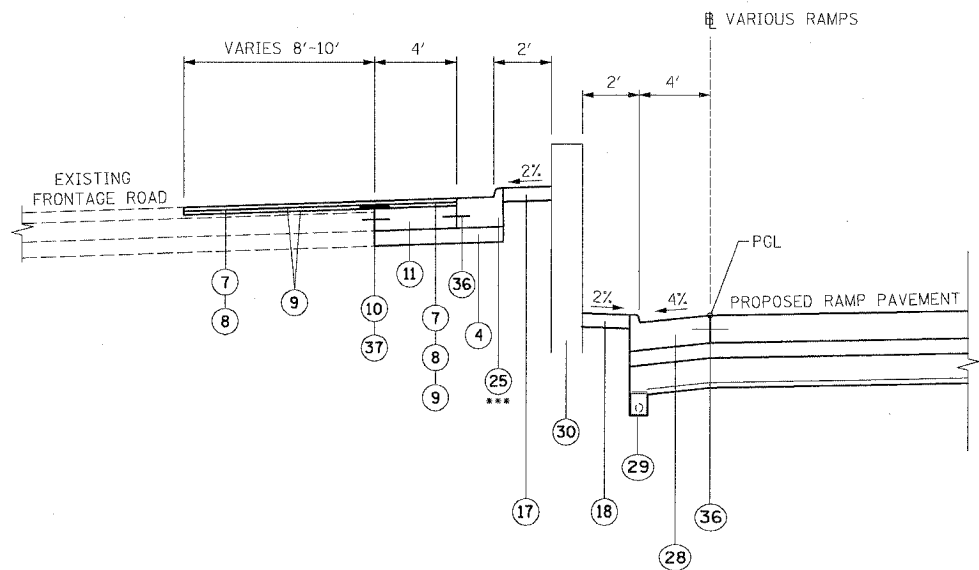

**PROPOSED TYPICAL OUTSIDE RAMP SHOULDER
TREATMENT WITH RETAINING WALL**

STATION	RAMP
5065+29.90 TO 5069+92	- 47A

PROPOSED LEGEND

- 1 CONTINUOUSLY REINFORCED PORTLAND CEMENT CONCRETE PAVEMENT 14" AND PAVEMENT REINFORCEMENT 14"
- 2 STABILIZED SUB-BASE 4"
- 3 STABILIZED SUB-BASE 6"
- 4 SUB-BASE GRANULAR MATERIAL, TYPE B 6"
- 5 SUB-BASE GRANULAR MATERIAL, TYPE B 24"
- 6 GEOTECHNICAL FABRIC FOR GROUND STABILIZATION
- 7 BITUMINOUS CONCRETE SURFACE COURSE, SUPERPAVE, MIX "D" N70, 1 1/2"
- 8 POLYMERIZED LEVELING BINDER (MACHINE METHOD), SUPERPAVE, IL-4.75, N50, 1"
- 9 BITUMINOUS MATERIALS (PRIME COAT)
- 10 STRIP REFLECTIVE CRACK CONTROL TREATMENT
- 11 PORTLAND CEMENT CONCRETE BASE COURSE 9 1/2"
- 12 PORTLAND CEMENT CONCRETE PAVEMENT 11" (JOINTED)
- 13 PORTLAND CEMENT CONCRETE SHOULDERS 11"
- 14 NOT USED
- 15 PORTLAND CEMENT CONCRETE SHOULDERS 14"
- 16 CONCRETE GUTTER, TYPE B
- 17 CONCRETE MEDIAN SURFACE, 5" (MODIFIED)
- 18 CONCRETE MEDIAN SURFACE, 6" (SPECIAL)
- 19 CONCRETE MEDIAN SURFACE, 6"
- 20 CONCRETE BARRIER, DOUBLE FACE, 32" HEIGHT
- 21 CONCRETE BARRIER, SINGLE FACE, 32" HEIGHT
- 22 CHAIN LINK FENCE, 4' (SPECIAL)
- 23 BARRIER BASE
- 24 BARRIER WALL MARKERS, TYPE C (80' C-C)
- 25 COMBINATION CONCRETE CURB AND GUTTER, TYPE B-6.12
- 26 COMBINATION CONCRETE CURB AND GUTTER, TYPE M-2.24
- 27 COMBINATION CONCRETE CURB AND GUTTER, TYPE M-4.24
- 28 COMBINATION CONCRETE CURB AND GUTTER, TYPE M-4.48 (MODIFIED)
- 29 PIPE UNDERDRAINS 6"
- 30 RETAINING WALL
- 31 MODIFIED EXISTING RETAINING WALL
- 32 SAND BACKFILL
- 33 GUARDRAIL
- 34 TOPSOIL FURNISH AND PLACE / SEEDING (SEE LANDSCAPING PLANS FOR DETAILS)
- 35 LONGITUDINAL SAWED OR CONSTRUCTION JOINT. FOR LONGITUDINAL SAWED JOINT, POUR IN PLACE NO. 6 DEFORMED EPOXY TIE BARS 30" LONG AT 30" C-C. FOR LONGITUDINAL CONSTRUCTION JOINT, DRILL AND GROUT NO. 8 DEFORMED EPOXY TIE BARS 24" LONG AT 24" C-C. (SHALL BE INCLUDED IN THE COST OF C.R.P.C.C. PAVEMENT 14")
- 36 LONGITUDINAL CONSTRUCTION JOINT. DRILL AND GROUT NO. 6 DEFORMED EPOXY TIE BARS 24" LONG AT 24" C-C. (SHALL BE INCLUDED IN THE COST OF THE APPLICABLE COMB. CONC. CURB AND GUTTER TYPE)
- 37 LONGITUDINAL CONSTRUCTION JOINT. DRILL AND GROUT NO. 8 DEFORMED EPOXY TIE BARS 24" LONG AT 24" C-C. (SHALL BE INCLUDED IN THE COST OF P.C.C. BASE COURSE 9")
- 38 LONGITUDINAL CONSTRUCTION JOINT. DRILL AND GROUT NO. 8 DEFORMED EPOXY TIE BARS 30" LONG AT 24" C-C. (SHALL BE INCLUDED IN THE COST OF THE APPLICABLE P.C.C. SHOULDERS TYPE)

PROPOSED ONE LANE RAMP

STATION	RAMP
⊗ 5065+59.83 TO 5070+19.63	- 47A
⊙ 7050+56.78 TO 7054+55.21	- 43C
⊙ 5043+00.73 TO 5047+94.01	- 43A
⊗ 7040+64.74 TO 7045+66.83	- 39D
⊙ 7043+08.57 TO 7043+58.07	- T35D
⊙ 5023+73.67 TO 5024+32.53	- T39A
⊙ 5003+60.75 TO 5004+04.93	- 35A
⊙ 7004+63.75 TO 7004+91.72	- 31D

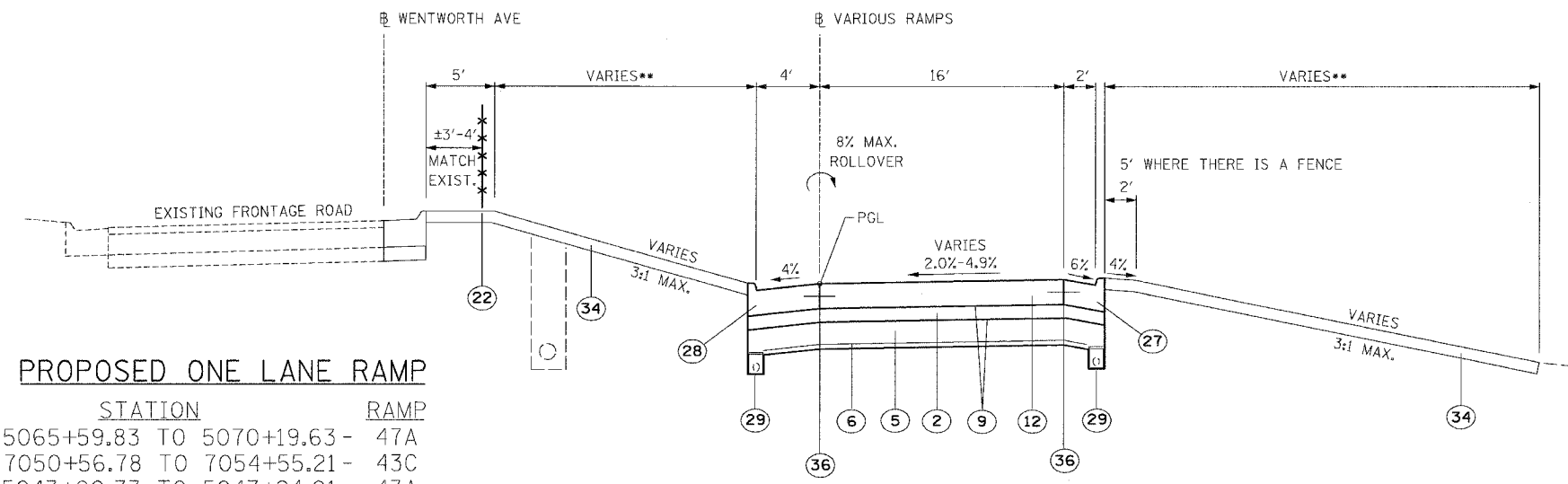

(INVERT RAMP 47A 24" GUTTER FLAG 2% ONTO RAMP PAVEMENT FROM STA 5070+30 TO THE FRONTAGE ROAD CURB AND GUTTER)
 (INVERT RAMP 43C 24" GUTTER FLAG 2% ONTO RAMP PAVEMENT FROM THE FRONTAGE ROAD CURB AND GUTTER TO STA 7050+28)
 (INVERT RAMP 43A 24" GUTTER FLAG 2% ONTO RAMP PAVEMENT FROM STA 5047+88 TO THE FRONTAGE ROAD CURB AND GUTTER)
 ⊗ SEE "PROPOSED TYPICAL INSIDE RAMP SHOULDER TREATMENT WITH RETAINING WALL" FOR LEFT SIDE TREATMENT.
 ⊙ SEE "EARTH RETAINING RAMP BARRIER WALL" FOR RIGHT SIDE TREATMENT.
 ⊗ SEE "PROPOSED TYPICAL OUTSIDE RAMP SHOULDER TREATMENT WITH RETAINING WALL" FOR RIGHT SIDE TREATMENT

RAMPS:

STRUCTURAL DESIGN TRAFFIC:	YEAR 2020
PV= 16,758	SU= 532
ROAD/STREET CLASSIFICATION:	MU= 1,710
P= 100%	CLASS 1
S= 100%	M= 100%
TRAFFIC FACTOR:	ACTUAL TF= 38.10
	MINIMUM TF= 16.75
AC GRADE:	BINDER:= -
SUBGRADE SUPPORT RATING:	SURFACE:= -
SSR= 2.00	

- NOTES:**
- SEE ROADWAY DETAILS FOR VARIABLE HEIGHT OF THE DOUBLE FACE BARRIER WALL AND FOR THE TYING OF THE BARRIER BASE TO THE PCC SHOULDER AND FOR THE LIMITS OF CONSTRUCTION OF THE SUB-BASE GRANULAR MATERIAL UNDER THE DOUBLE FACE BARRIER WALL.
 - SHOULDER RUMBLE STRIPS SHALL BE CONSTRUCTED IN THE PROPOSED AND EXISTING SHOULDERS OF THE LOCAL AND EXPRESS LANES ACCORDING TO IDOT STANDARD 642001.
 - TYPICAL SECTIONS NEED TO BE VERIFIED WITH THE ROADWAY PLANS AS THEY ARE A REPRESENTATION OF THE PLANS. THEY DO NOT SHOW ALL CONFIGURATIONS, JUST THE MOST PREDOMINANT.
- SEE PLAN SHEETS FOR DETAILS

BOWMAN, BARRETT & ASSOCIATES INC.
 CONSULTING ENGINEERS
 Chicago, Illinois
 312.228.0100
 www.bbainc.com

REVISIONS	
NAME	DATE

ILLINOIS DEPARTMENT OF TRANSPORTATION
 F.A.I. 94/90 (DAN RYAN EXPRESSWAY)
 GARFIELD BLVD TO 31ST STREET (SB LOCAL LANES)

PROPOSED TYPICAL SECTIONS

SCALE: NTS
 DATE: 06/09/06

DRAWN BY: JDC
 CHECKED BY: RS

PRTYP-7

11/6/09 11:58:39 AM