

F.A. RTE.	SECTION	COUNTY	TOTAL SHEETS	SHEET NO.
311	IN & TS	KENDALL	174	78
STA.		TO STA.		
FED. ROAD DIST. NO.		ILLINOIS FED. AID PROJECT		

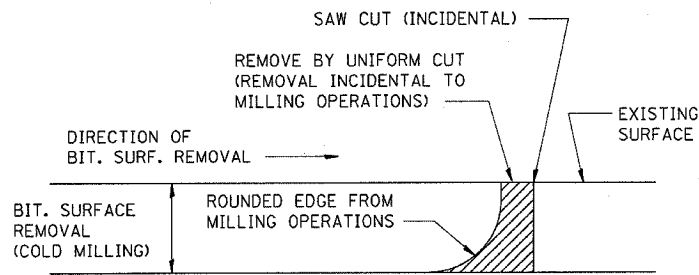

NOTE: WHEN MILLING OPERATIONS PRODUCE A ROUNDED EDGE, THEN A SAW CUT SHALL BE USED TO MANUFACTURE A PERPENDICULAR EDGE AS SHOWN IN THE DETAIL. THE ENGINEER SHALL BE THE SOLE JUDGE CONCERNING THE USE OF THIS DETAIL

**BITUMINOUS DETAIL AT BUTT JOINTS**

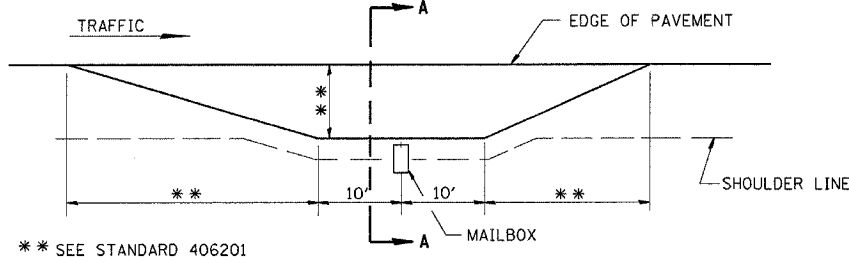

\*\* SEE STANDARD 406201

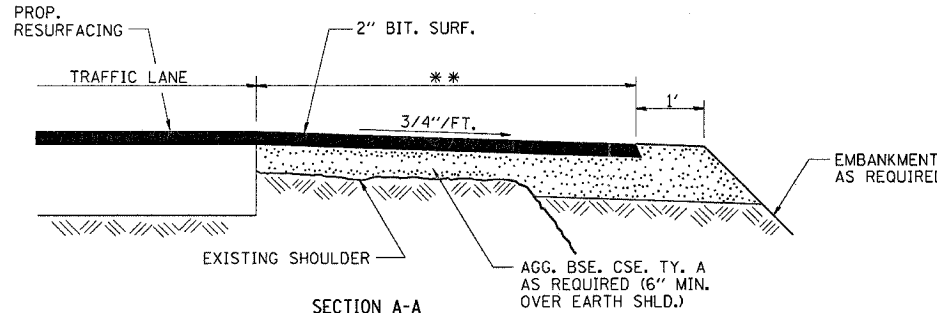

SECTION A-A  
MAILBOX TURNOUT DETAILS

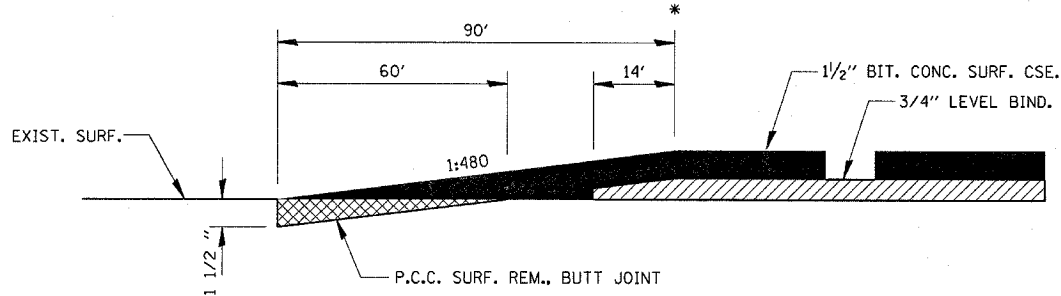

\* IL 71, STA. 559+87.26  
IL 71, STA 584+05.21  
IL 126, STA 59+00

**GENERAL NOTES:**

1. THE CURB AND GUTTER CONFIGURATION SHALL BE M-4.24 AS SHOWN BELOW AND WILL BE PAID FOR PER FOOT FOR EACH RESPECTIVE PAY ITEM.
2. SEE STD. 606001 & AND 606301 FOR ADDITIONAL DETAILS.
3. ALL MATERIALS, LABOR, AND EQUIPMENT REQUIRED TO COMPLETE THE WORK SHALL BE INCLUDED IN THE COST OF ISLAND PAVEMENT (SPECIAL) PER SQUARE YARD.
4. REMOVAL OF EXISTING PAVEMENT NECESSARY TO COMPLETE THE WORK WILL BE PAID FOR AT THE CONTRACT UNIT PRICE FOR PAVEMENT REMOVAL PER SQUARE YARD.

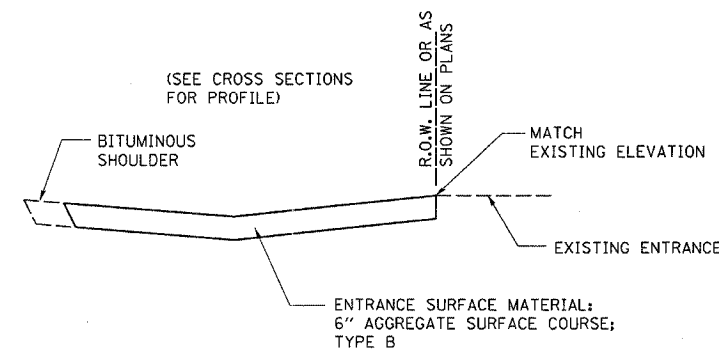
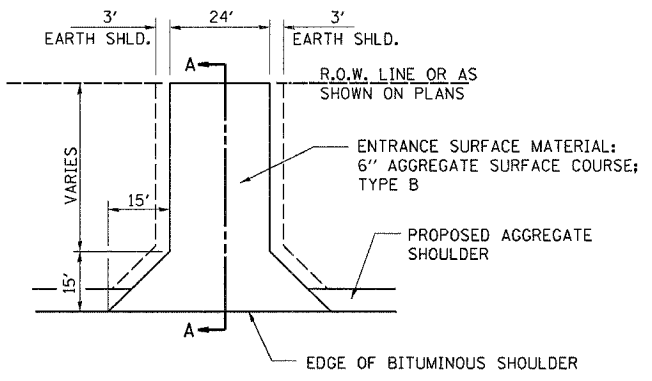
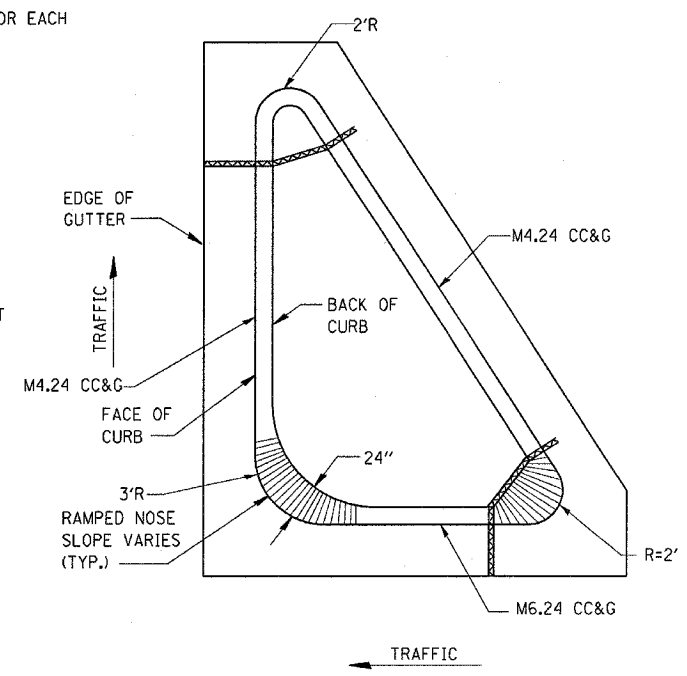

**FIELD ENTRANCE DETAIL**

\* VARIES - SEE STANDARD 606001

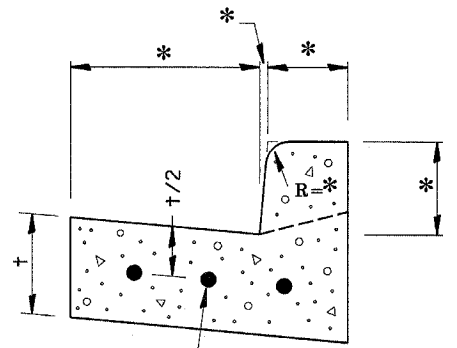

CONTINUOUSLY REINFORCED WITH 3 - #4 BARS EVENLY SPACED  
REINFORCEMENT SHALL NOT BE PAID FOR SEPARATELY BUT WILL BE INCLUDED IN THE CONTRACT UNIT PRICE FOR CC&G.

**REINFORCEMENT DETAIL FOR COMBINATION CONCRETE CURB AND GUTTER**

REVISIONS	
NAME	DATE

ILLINOIS DEPARTMENT OF TRANSPORTATION

**DETAILS**

SCALE: VERT. HORIZ.  
DATE  
DRAWN BY  
CHECKED BY