

DESIGNER: CLARK JONES  
PHONE NO: (309) 671-3452

**INDEX OF SHEETS:**

1. COVER SHEET
- 2-3. COMMITMENTS & GENERAL NOTES
- 4-6. SUMMARY OF QUANTITIES
7. TYPICAL SECTIONS
8. QUANTITIES NOT OTHERWISE SHOWN
9. GENERAL SITE PLAN
10. BUTT JOINT DETAIL
11. TRAFFIC STAGING & CONTROL
12. PLAN AND ELEVATION
13. STAGE CONSTRUCTION DETAIL
- 14-22. BRIDGE REPAIR DETAILS
- 23-30B SCOUR MITIGATION PLAN

**STANDARDS REQUIRED:**

- 420401-05 701101-01 702001-06  
 515001-02 701106-01 704001-02  
 630001-06 701201-02 780001-01  
 631031-05 701306-01 781001-02  
 631032-02 701321-08

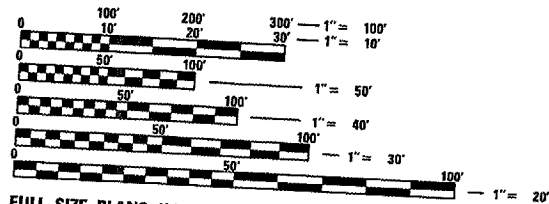

FULL SIZE PLANS HAVE BEEN PREPARED USING STANDARD ENGINEERING SCALES. REDUCED SIZED PLANS WILL NOT CONFORM TO STANDARD SCALES. IN MAKING MEASUREMENTS ON REDUCED PLANS, THE ABOVE SCALES MAY BE USED.

J.U.L.I.E.  
 JOINT UTILITY LOCATION INFORMATION FOR EXCAVATION  
 1-800-892-0123

CONTRACT NO. 68484 CAT. NO. 033065-00D

STATE OF ILLINOIS  
 DEPARTMENT OF TRANSPORTATION  
 DIVISION OF HIGHWAYS

**PROPOSED  
 HIGHWAY PLANS**

FAP ROUTE 701 (IL 122)  
 SECTION (128 BR)I-1  
 TAZEWELL COUNTY  
 C-94-075-05

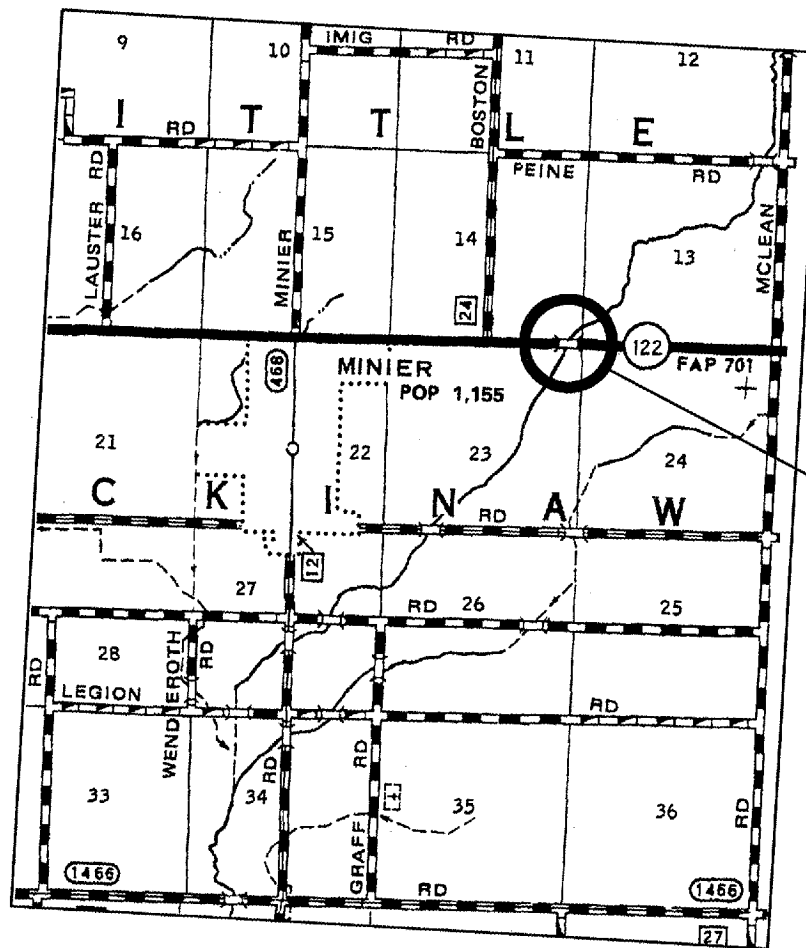

LOCATION MAP

F.A.P. RY.	SECTION	COUNTY	TOTAL SHEETS	SHEET NO.
701	(128BR)I-1	TAZEWELL	30	1

CONTRACT NO. 68484

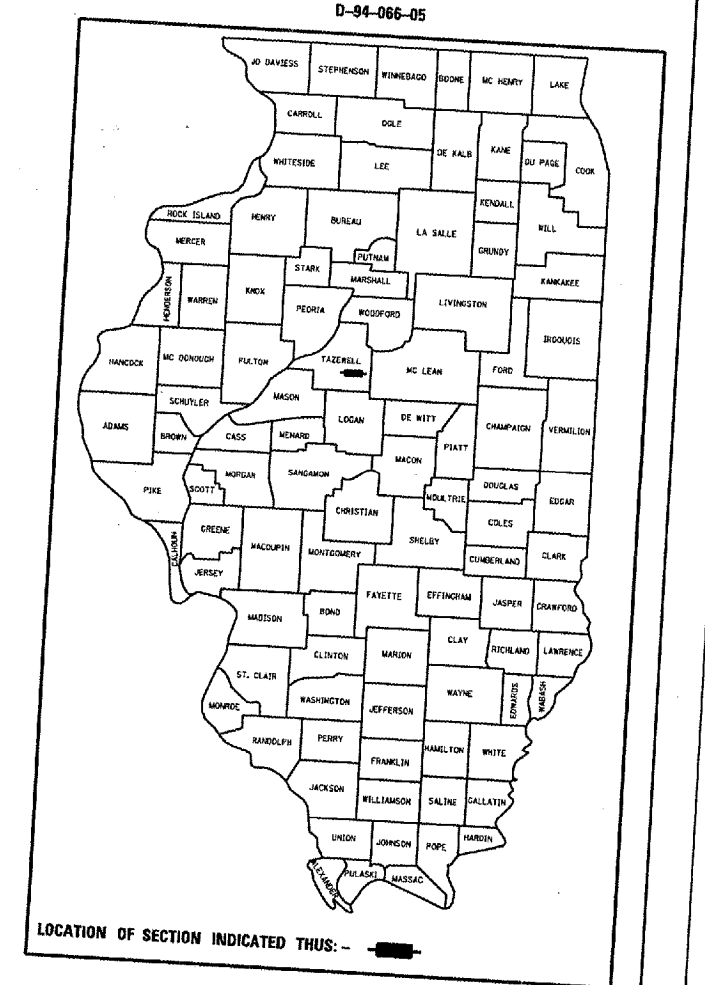

SCOUR MITIGATION AND DECK BEAM REPLACEMENT ON STRUCTURE CARRYING IL. 122 OVER SUGAR CREEK (SN. 090-0058), 1 MILE EAST OF MINIER

STATE OF ILLINOIS  
 DEPARTMENT OF TRANSPORTATION  
 DIVISION OF HIGHWAYS

SUBMITTED 3/31/06

*Joseph E. Crowe*  
 DEPUTY DIRECTOR OF HIGHWAYS, REGION ENGINEER  
 May 12, 2006

*Mike Jene*  
 ENGINEER OF DESIGN AND ENVIRONMENT  
 May 12, 2006

*Milton R. Sees, P.E.*  
 DIRECTOR OF HIGHWAYS, CHIEF ENGINEER

PRINTED BY THE AUTHORITY  
 OF THE STATE OF ILLINOIS

REVISD 7-21-06

PROJECT ENGINEER: JIM MILLER  
 PHONE NO: (309) 671-3451

F.A.P. RITE	SECTION	COUNTY	TOTAL SHEETS	SHEET NO.
T01	(1288R01-1	TAZEWELL	30	3
STA. 77+63.98		TO STA. 78+48.02		
FED. ROAD DIST. NO. 4 ILLINOIS FED. AID PROJECT				

## GENERAL NOTES

1. Plan dimensions and details relative to existing structure (including High Water Elevation) have been taken from existing plans and are subject to nominal construction variations. It shall be the Contractor's responsibility to verify such dimensions and details in the field and make necessary approved adjustments prior to construction or ordering of materials. Such variations shall not be cause for additional compensation for a change in the scope of the work. However, the Contractor will be paid for the quantity actually furnished at the unit price bid for the work.
2. All information shown in each structure's Waterway Information Table was provided by the Illinois Department of Transportation.
3. Commitments are not to be altered without the written approval of all parties to which the commitment was made.
4. The Contractor shall be responsible for diverting the water flow from the construction area of each site. The Contractor may use either method of dewatering as described in the Dewatering Special Provision.
5. During site preparation, areas below the final grade shall be brought to grade by placing compacted layers of Granular Subbase Material, Type C; areas of soft or otherwise unsuitable subgrade soils shall be excavated and replaced with compacted layers of Granular Subbase Material, Type C. Removal and replacement of unsuitable material shall be as directed by the Engineer and will be paid for in accordance to Article 109.04 (Force Account Basis) of the Standard Specifications. An assumed quantity for Granular Subbase Material, Type C, is included as part of each structure's mitigation details.
6. Layout of scour protection systems may be varied in the field to suit ground conditions as directed by the engineer.
7. All areas disturbed during construction shall be graded, fertilized, seeded and mulched as directed by the Engineer. Sections 250 and 251 of the Standard Specifications shall govern this work.
8. It is anticipated that the majority of the scour work will not require highway traffic lane closures. Work which would require extended lane closures shall be done while Standard 701321 is in use. Otherwise, the Contractor is restricted to one-lane daytime only closures in accordance with IDOT Standards 701201 and 701301.
9. GABION ANCHOR STAKE layout shown on plan sheets is for information and estimation purposes only. Actual layout shall be determined in the field by the Contractor and approved by the Engineer and shall conform to the procedures stated in the special provisions.
10. STONE RIPRAP, CLASS A5 is shown in plan details at a nominal 30" thickness, which is the minimum combined thickness of bedding stone and riprap allowed by the Standard Specifications.

## COMMITMENTS

There are no commitments for this project.

## SCOUR CONSTRUCTION SEQUENCE

1. Install dewatering system and divert water flow from the construction area.
2. Excavate to the lines, grades, contours, and dimensions shown. The prepared area shall be inspected and approved by the Engineer before further work can take place.
3. Install filter fabric on the graded surfaces as shown on the drawings.
4. Install site specific scour countermeasures. See detail sheets for specific installation procedures.
5. Remove dewatering system. Grade and seed ground disturbed during construction.

PLOT DATE  
 FILE NAME  
 PLOT SCALE  
 REFERENCE

**REVISED**  
**7-21-06**  
**SHEET**

REVISIONS	
NAME	DATE

ILLINOIS DEPARTMENT OF TRANSPORTATION

## COMMITMENTS & GENERAL NOTES

SCALE: VERT.      DRAWN BY CEJ  
 HORIZ.              CHECKED BY  
 DATE 03-24-2006

F.A.P. RTE.	SECTION	COUNTY	TOTAL SHEETS	SHEET NO.
701	128BR11-1	TAZEWELL	30	4
STA. 77+63.98		TO STA. 78+48.02		
FED. ROAD DIST. NO. 4 ILLINOIS FED. AID PROJECT				

# SUMMARY OF QUANTITIES

## CONSTRUCTION TYPE CODE

CODE NO.	ITEM	UNIT	CONSTRUCTION TYPE CODE		TOTAL
			X080-2A	SFTY -3N	
			100% STATE		
20300100	CHANNEL EXCAVATION	CU. YD.	1090		1090
20400800	FURNISHED EXCAVATION	CU. YD.	76		76
25000300	SEEDING, CLASS 3	ACRE	0.03		0.03
25000400	NITROGEN FERTILIZER NUTRIENT	POUND	3		3
25000500	PHOSPHORUS FERTILIZER NUTRIENT	POUND	3		3
25000600	POTASSIUM FERTILIZER NUTRIENT	POUND	3		3
25100630	EROSION CONTROL BLANKET	SQ. YD.	152		152
28000400	PERIMETER EROSION BARRIER	FOOT	92		92
△ 28100209	STONE RIPRAP, CLASS A5	TON	1,165		1,165
28200200	FILTER FABRIC	SQ. YD.	1067		1067
28400100	GABIONS	CU. YD.	339		339
△ 28401000	SLOPE MATTRESS 12"	SQ. YD.	479		479
△ 31101900	SUB-BASE GRANULAR MATERIAL, TYPE C	TON	479		479
40600100	BITUMINOUS MATERIALS (PRIME COAT)	GALLON	148		148
40600300	AGGREGATE (PRIME COAT)	TON	1		1
40600980	BITUMINOUS SURFACE REMOVAL-BUTT JOINT	SQ. YD.	160		160
48101200	AGGREGATE SHOULDERS, TYPE B	TON	2		2
50101500	REMOVAL OF EXISTING SUPERSTRUCTURES	EACH	1		1
50300225	CONCRETE STRUCTURES	CU. YD.	6		6
50300260	BRIDGE DECK GROOVING	SQ. YD.	273		273

PLOT DATE \* MONITOR \*  
FILE NAME \* PFILE \*  
PLOT SCALE \* SCALES \*  
REFERENCE \* REF \*

△ **REVISED**  
7-21-06

REVISIONS	
NAME	DATE

ILLINOIS DEPARTMENT OF TRANSPORTATION  
**SUMMARY OF QUANTITIES**  
SCALE: VERT. \_\_\_\_\_  
DATE: 03-24-2006  
DRAWN BY: CEJ  
CHECKED BY: \_\_\_\_\_

F.A.P. RTE.	SECTION	COUNTY	TOTAL SHEETS	SHEET NO.
701	(128BR)-1	TAZEWELL	30	9
STA.	TO STA.			
EXISTING CONDITIONS:				
CONTRACT NO. 68484				

**Notes**

1. All signs required will be supplied to the contractor by I.D.O.T.
2. The contractor shall furnish the posts AND erect signs at the locations shown on this sheet, as directed by the R.E./R.T. The posts shall remain the property of the contractor.
3. The contractor shall give Illinois Department of Transportation, Bureau of Operations two weeks notice for signs. The contractor shall pick up the signs at the location given in the Special Provisions AND return them upon completion of the contract.
4. The above noted work shall be paid for at the contract unit price, Lump Sum, for Wide Load Signing AND no other compensation will be allowed.
5. Sign spacing will be 400' or to fit field conditions.
6. The height to the bottom of the lowest sign shall not be less than 6'.

DATE	BY	REVISION

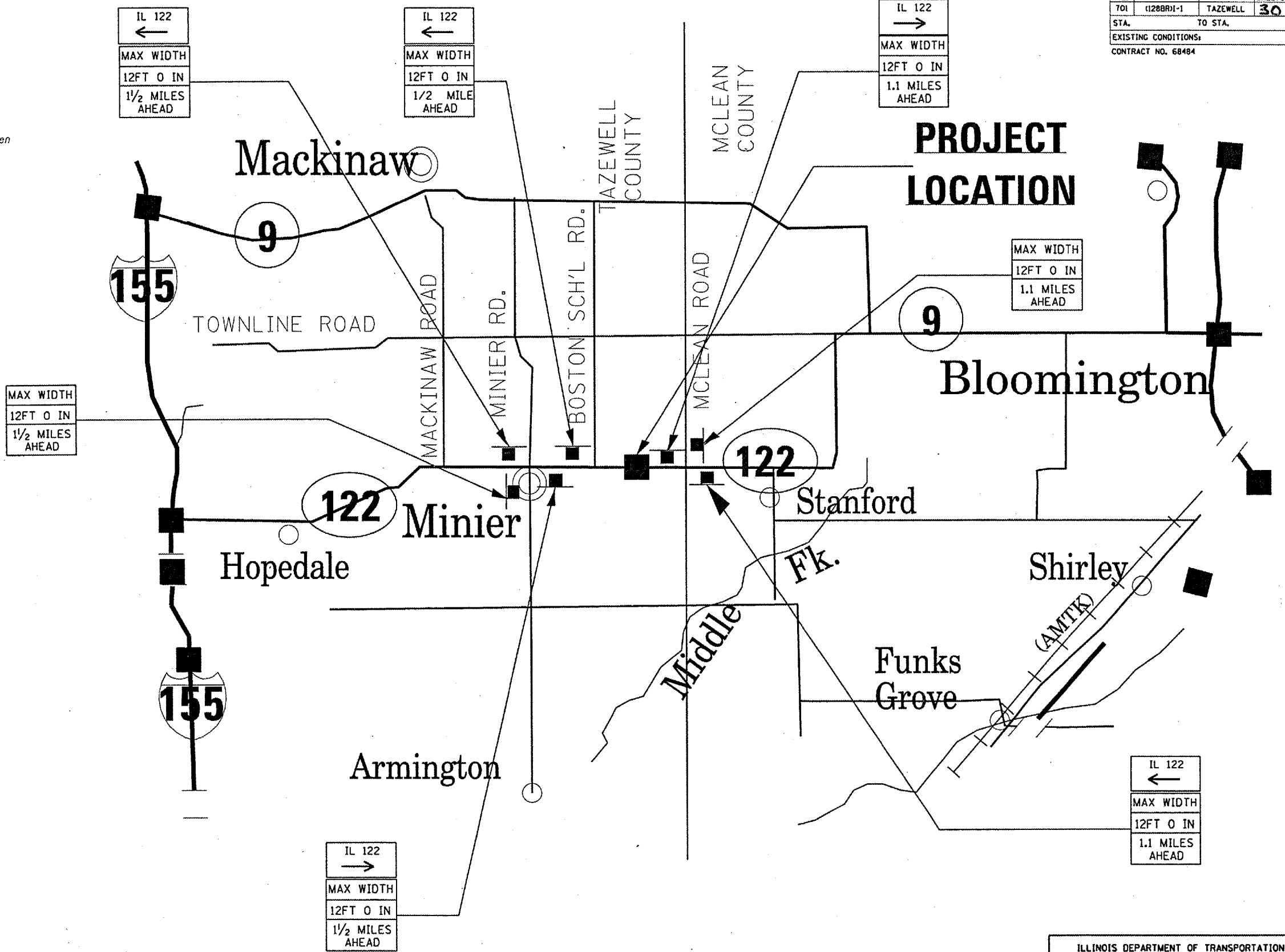

**SIGNS REQUIRED**

MAX WIDTH 12FT 0 IN 1.1 MILES AHEAD	(3)	IL 122 →	(2)
MAX WIDTH 12FT 0 IN 1 1/2 MILES AHEAD	(3)	IL 122 ←	(3)
MAX WIDTH 12FT 0 IN 1 1/2 MILE AHEAD	(1)		

**REVISED**  
7-21-06  
**SHEET**

**BRIDGE DECK REPLACEMENT  
IL RT 122 OVER SUGAR CREEK**

REVISIONS	
NAME	DATE

ILLINOIS DEPARTMENT OF TRANSPORTATION  
**WIDE LOAD SIGN LOCATION**  
F.A.P. RTE. 701  
SECTION (128BR)-1  
TAZEWELL COUNTY  
SCALE: NONE  
DATE: 03/24/2006  
DRAWN BY: KBF  
CHECKED BY: AJE

PLOT DATE: \*DATE-TIME\*

•SHEET  
•DIM-SPEC  
•REF-  
•REV-

BENCHMARK: CHISLED SQUARE ON BRIDGE DECK  
ON SOUTHWEST CORNER  
ELEV = 100.00

EXISTING STRUCTURE: SN 090-0058 IS A 33'-0" WIDE x 84'-0 1/2"  
LONG P.C.C. DECK BEAM SUPERSTRUCTURE WITH R.C. CLOSED ABUTMENTS.

ROUTE NO.	SECTION	COUNTY	TOTAL SHEETS	SHEET NO.
FAP 701	*	TAZEWELL	30	23
FED. ROAD DIST. NO. 4		ILLINOIS	FED. AID PROJECT	

INDEX OF SHEETS

SHEET NUMBER	DESCRIPTION
1	GENERAL PLAN AND PROFILE, SUMMARY OF QUANTITIES, LOCATION MAP
2	R.O.W. PLAN
3	PROPOSED SITE PLAN
4	PROPOSED DIMENSION PLAN
5	SITE PROFILE
6-8	CROSS SECTIONS

\* (128BR)I-1

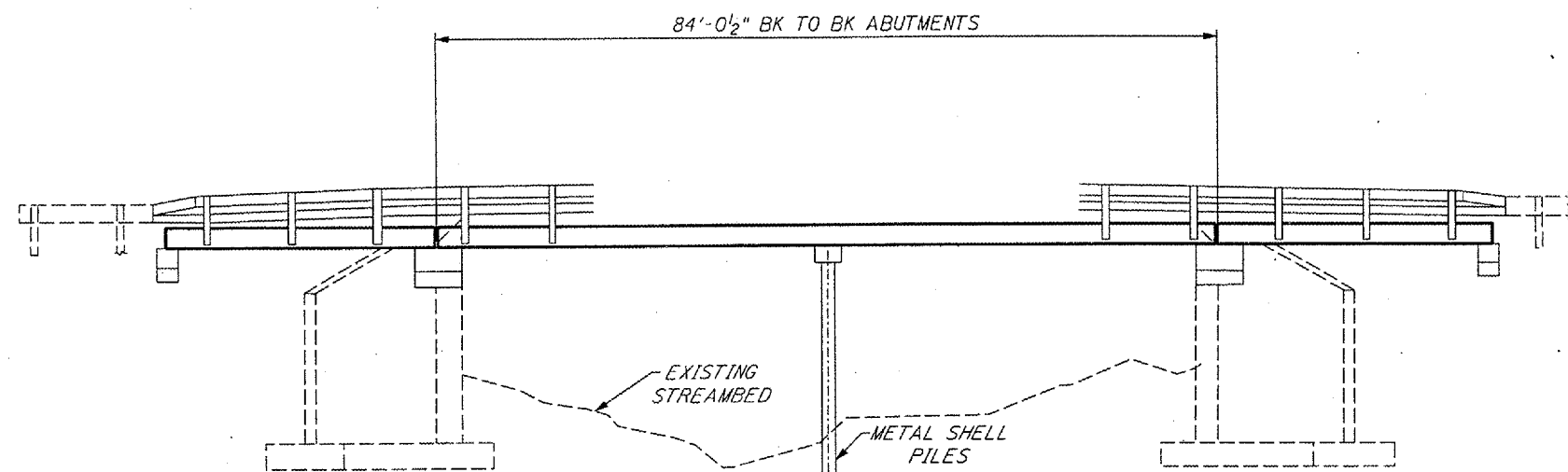

ELEVATION

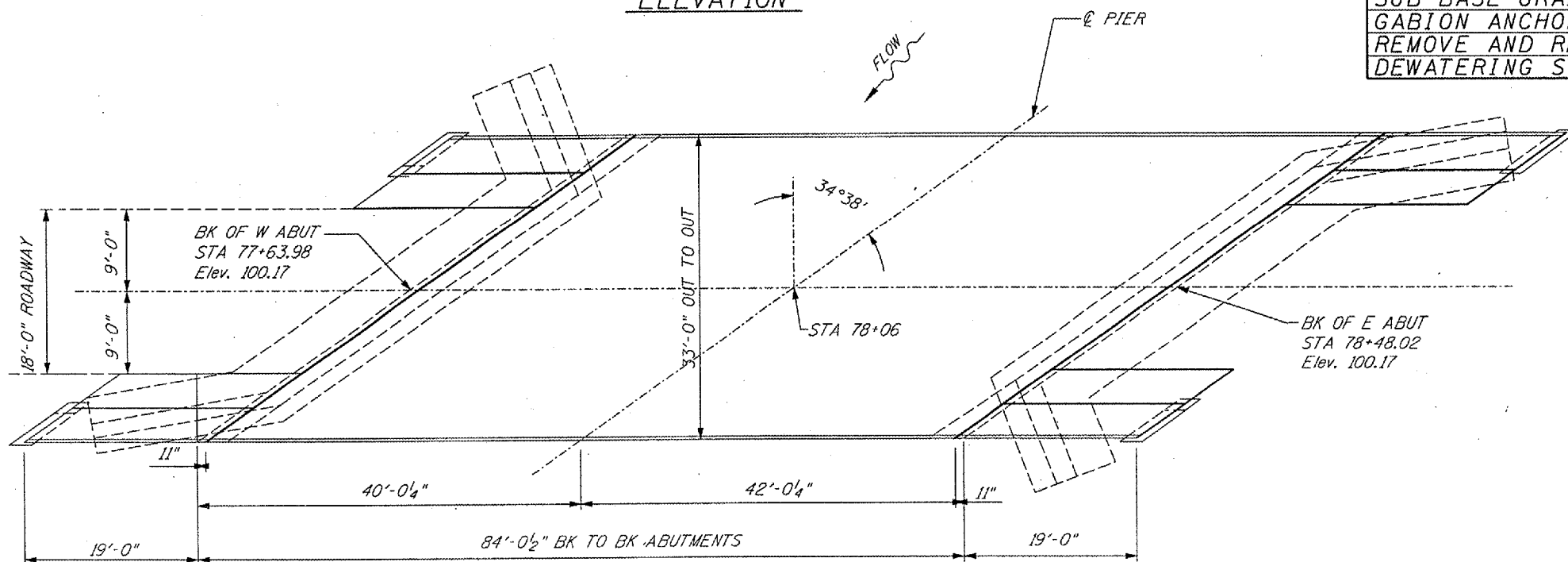

PLAN

EXISTING BRIDGE



**REVISED**  
7-21-06  
**SHEET**

BILL OF MATERIALS

ITEM	UNIT	TOTAL
CHANNEL EXCAVATION	CU YD	1090
PERIMETER EROSION CONTROL BARRIER	FOOT	92
STONE RIP-RAP, CLASS A5	TONS	1165
FILTER FABRIC FOR RIPRAP	SQ YD	1067
GABIONS	CU YD	339
SUB-BASE GRANULAR MATERIAL, TYPE C	TONS	395
GABION ANCHOR STAKES	EACH	103
REMOVE AND REPLACE STEEL PLATE GUARD RAIL, TYPE A	FOOT	50
DEWATERING STRUCTURE NO. 1	EACH	1

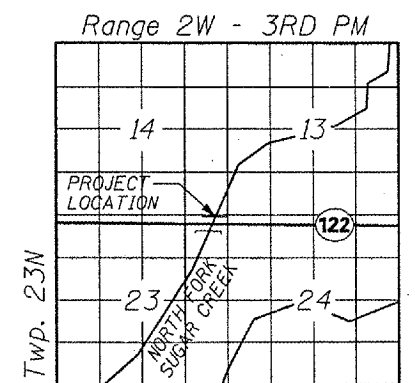

LOCATION SKETCH

WATERWAY/SCOUR INFORMATION

DESIGN FLOOD	100 YRS
DRAINAGE AREA	23.4 SQ MI.
FLOW	4,299 CFS
FLOW DEPTH	10.76 FT
REQUIRED OPENING	515 SQ FT
PROVIDED OPENING	842 SQ FT
CONTRACTION SCOUR DEPTH	8 FT

ILLINOIS DEPARTMENT OF TRANSPORTATION  
GENERAL PLAN & ELEVATION  
S.N. 090-0058  
F.A.P. 701 (IL 122) OVER  
NORTH FORK SUGAR CREEK  
TAZEWELL COUNTY  
SHEET 1 OF 8

ROUTE NO.	SECTION	COUNTY	TOTAL SHEETS	SHEET NO.
F.A.P. 701	*	TAZEWELL	30	24
FED. ROAD DIST. NO. 4		ILLINOIS	FED. AID PROJECT	
* (128BR)I-1				

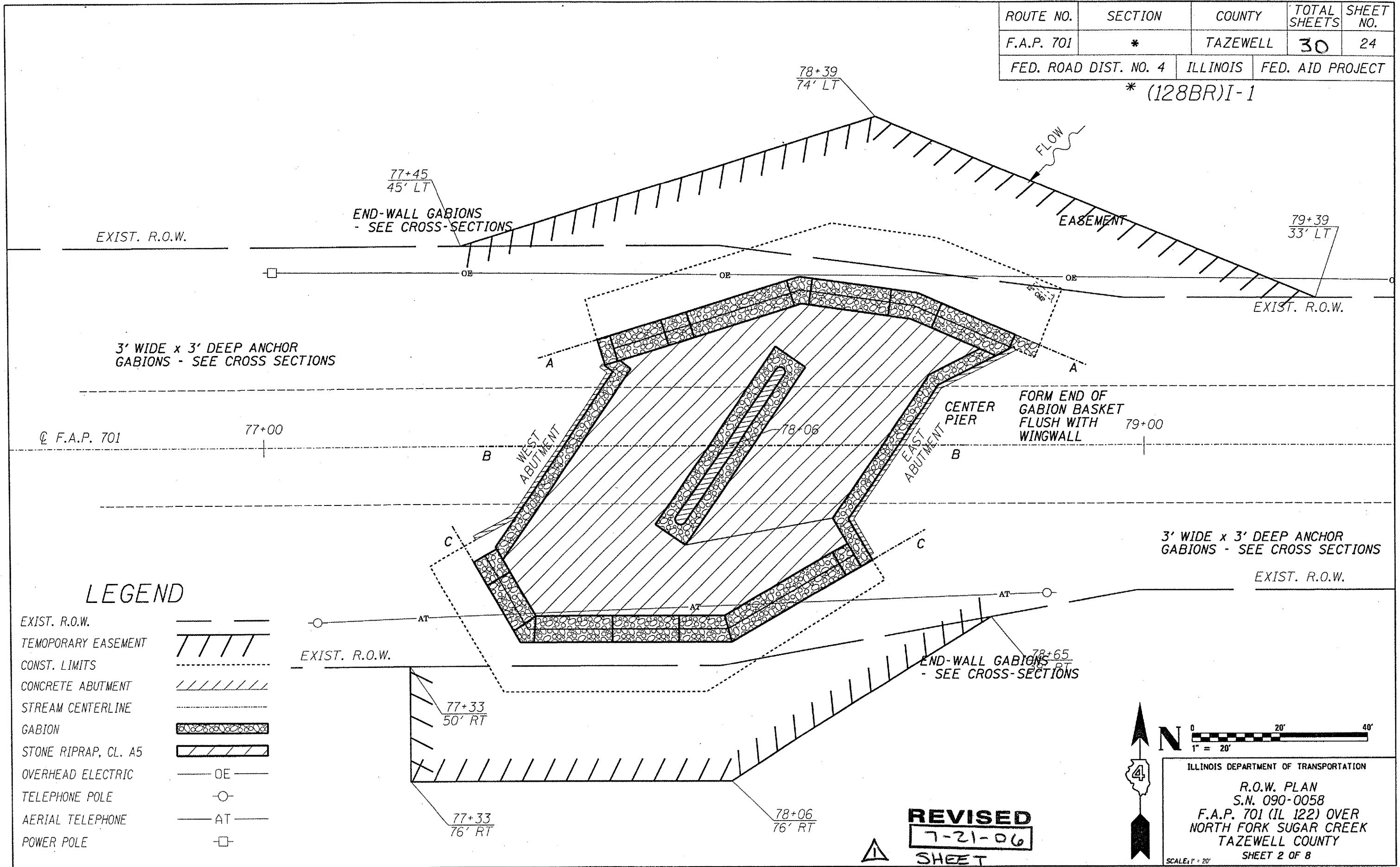

**LEGEND**

- EXIST. R.O.W. ————
- TEMPORARY EASEMENT / / / /
- CONST. LIMITS - - - - -
- CONCRETE ABUTMENT / / / /
- STREAM CENTERLINE ————
- GABION
- STONE RIPRAP, CL. A5
- OVERHEAD ELECTRIC ———— OE ————
- TELEPHONE POLE ———— ○ ————
- AERIAL TELEPHONE ———— AT ————
- POWER POLE ———— □ ————

**REVISED**  
**7-21-06**  
**SHEET**

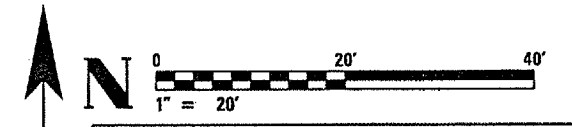

ILLINOIS DEPARTMENT OF TRANSPORTATION  
R.O.W. PLAN  
S.N. 090-0058  
F.A.P. 701 (IL 122) OVER  
NORTH FORK SUGAR CREEK  
TAZEWELL COUNTY  
SHEET 2 OF 8  
SCALE: 1" = 20'

ROUTE NO.	SECTION	COUNTY	TOTAL SHEETS	SHEET NO.
F.A.P. 701	*	TAZEWELL	30	25
FED. ROAD DIST. NO. 4		ILLINOIS	FED. AID PROJECT	

(128BR)I-1

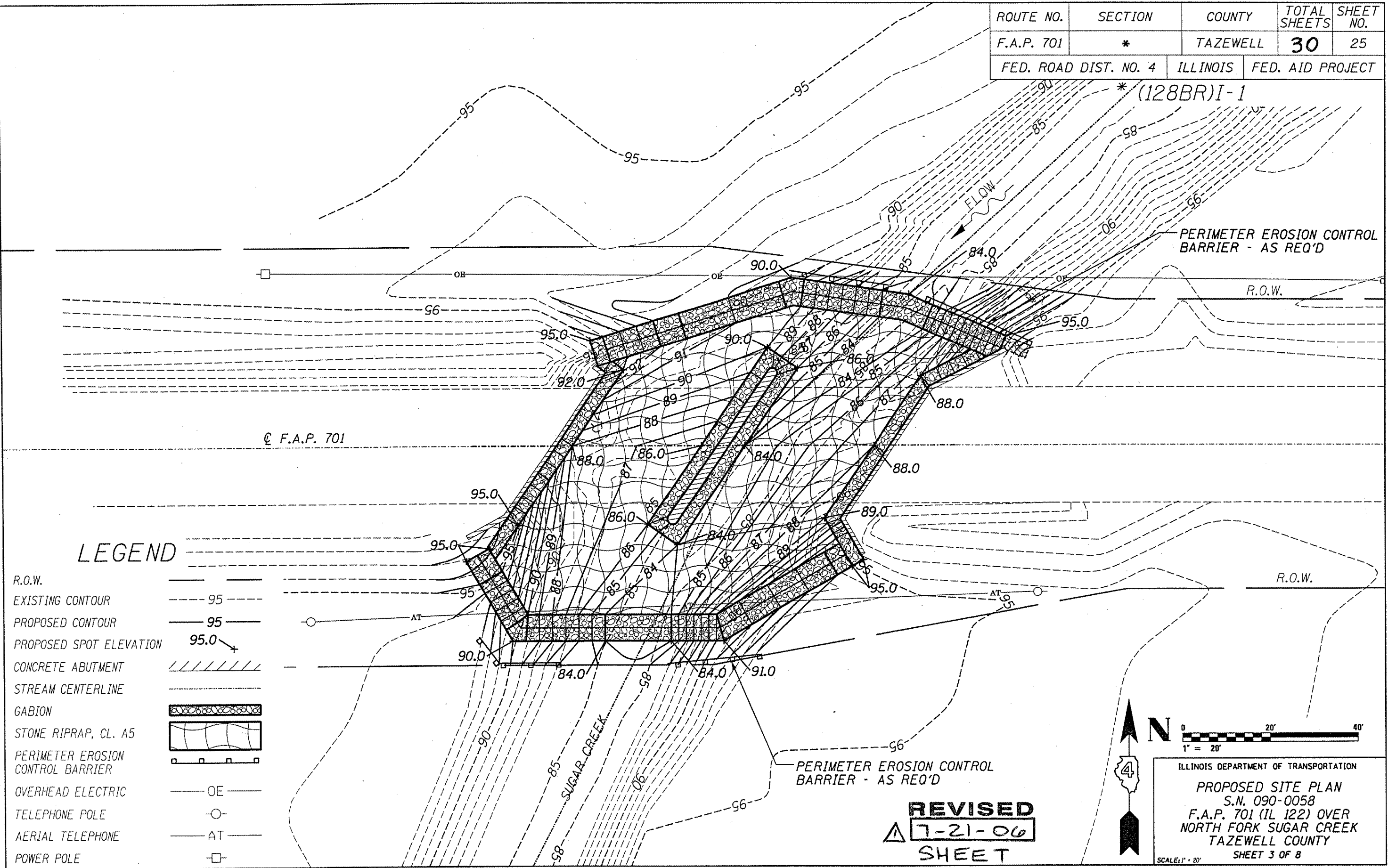

**LEGEND**

- R.O.W. —————
- EXISTING CONTOUR - - - - - 95
- PROPOSED CONTOUR ———— 95
- PROPOSED SPOT ELEVATION 95.0 ↘
- CONCRETE ABUTMENT // / / / /
- STREAM CENTERLINE - - - - -
- GABION [Cross-hatch pattern]
- STONE RIPRAP, CL. A5 [Wavy line pattern]
- PERIMETER EROSION CONTROL BARRIER [Square symbols]
- OVERHEAD ELECTRIC ———— OE ————
- TELEPHONE POLE ———— O ————
- AERIAL TELEPHONE ———— AT ————
- POWER POLE ———— □ ————

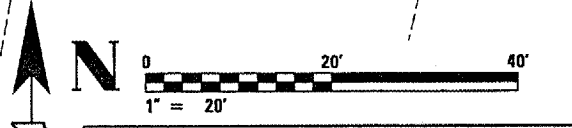

ILLINOIS DEPARTMENT OF TRANSPORTATION  
**PROPOSED SITE PLAN**  
 S.N. 090-0058  
 F.A.P. 701 (IL 122) OVER  
 NORTH FORK SUGAR CREEK  
 TAZEWELL COUNTY  
 SHEET 3 OF 8

**REVISED**  
 7-21-06  
**SHEET**

ROUTE NO.	SECTION	COUNTY	TOTAL SHEETS	SHEET NO.
F.A.P. 701	*	TAZEWELL	30	26
FED. ROAD DIST. NO. 4		ILLINOIS	FED. AID PROJECT	

\* (128BR)I-1

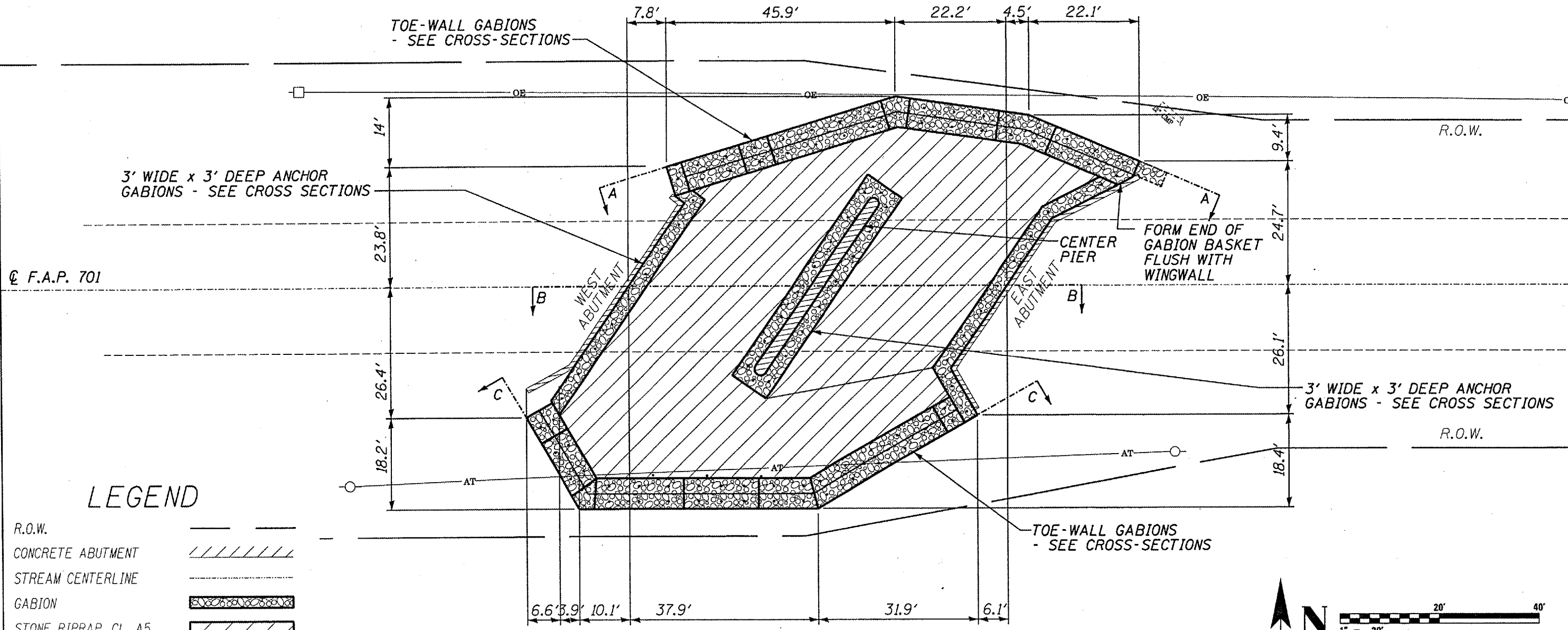
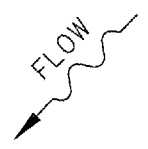

**LEGEND**

- R.O.W. ————
- CONCRETE ABUTMENT
- STREAM CENTERLINE
- GABION
- STONE RIPRAP, CL. A5
- GABION ANCHOR STAKE
- OVERHEAD ELECTRIC ———— OE ————
- TELEPHONE POLE ———— AT ————
- AERIAL TELEPHONE ———— AT ————
- POWER POLE

**REVISED**  
 7-21-06  
**SHEET**

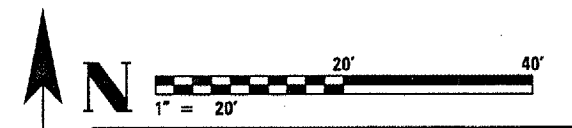

ILLINOIS DEPARTMENT OF TRANSPORTATION  
 PROPOSED DIMENSION PLAN  
 S.N. 090-0058  
 F.A.P. 701 (IL 122) OVER  
 NORTH FORK SUGAR CREEK  
 TAZEWELL COUNTY  
 SHEET 4 OF 8



ROUTE NO.	SECTION	COUNTY	TOTAL SHEETS	SHEET NO.
F.A.P. 701	*	TAZEWELL	30	27
FED. ROAD DIST. NO. 4		ILLINOIS	FED. AID PROJECT	

\* (128BR)I-1

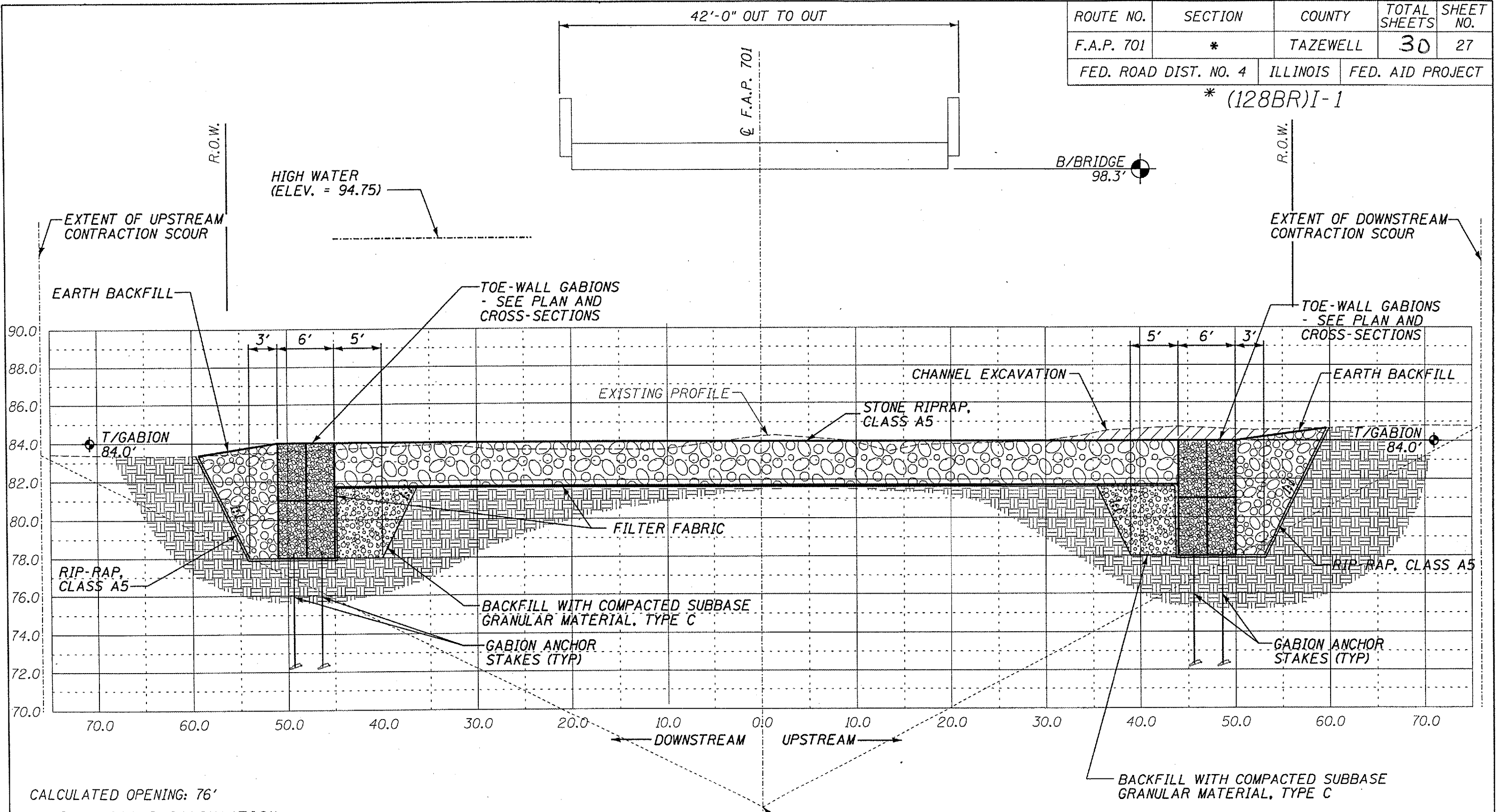

CALCULATED OPENING: 76'

MAXIMUM SCOUR CALCULATION:  
 CONTRACTION SCOUR EQUATION = 8 FT  
 LOCAL SCOUR EQUATION = 16 FT  
 ADJUSTMENT FACTOR FOR TOTAL STREAMBED ARMORING = 0.7  
 TOTAL LOCAL SCOUR = 11.2 FT  
 TOTAL COMBINED SCOUR = 19.2 FT

ANTICIPATED DEPTH OF MAXIMUM SCOUR (ELEV = 64.8')

**REVISED**  
 7-21-06  
 SHEET

ILLINOIS DEPARTMENT OF TRANSPORTATION  
 SITE PROFILE  
 S.N. 090-0058  
 F.A.P. 701 (IL 122) OVER  
 NORTH FORK SUGAR CREEK  
 TAZEWELL COUNTY  
 SHEET 5 OF 8  
 SCALE: VERT. 1" = 5' HORIZ. 1" = 10'

ROUTE NO.	SECTION	COUNTY	TOTAL SHEETS	SHEET NO.
F.A.P. 701	*	TAZEWELL	30	28
FED. ROAD DIST. NO. 4		ILLINOIS	FED. AID PROJECT	

\* (128BR)I-1

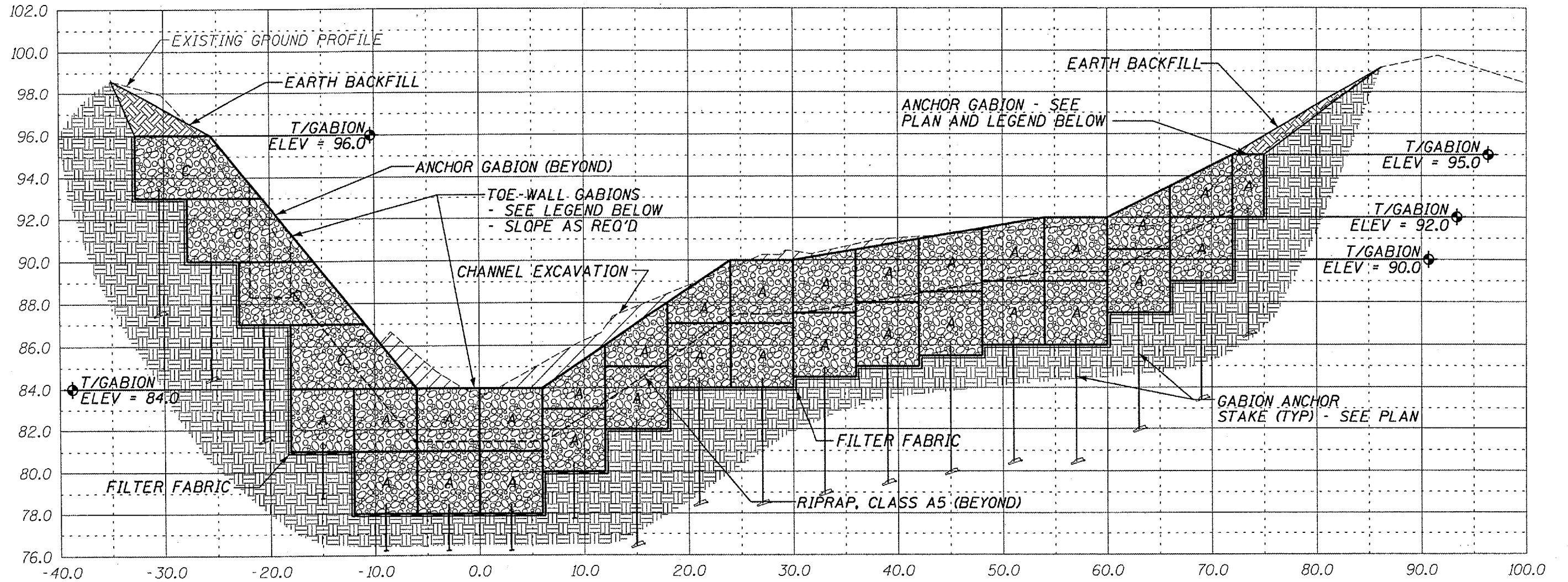

SECTION A-A THROUGH NORTH GABION TOE-WALL

**REVISED**  
 7-21-06  
 SHEET

MARK	LENGTH	WIDTH	HEIGHT
A	6'	3'	3'
C	12'	3'	3'

ILLINOIS DEPARTMENT OF TRANSPORTATION  
 SITE CROSS SECTION  
 S.N. 090-0058  
 F.A.P. 701 (IL 122) OVER  
 NORTH FORK SUGAR CREEK  
 TAZEWELL COUNTY  
 SHEET 6 OF 8

SCALE: VERT. 1" = 5' HORIZ. 1" = 10'

ROUTE NO.	SECTION	COUNTY	TOTAL SHEETS	SHEET NO.
F.A.P. 701	*	TAZEWELL	30	29
FED. ROAD DIST. NO. 4		ILLINOIS	FED. AID PROJECT	

\* (128BR)I-1

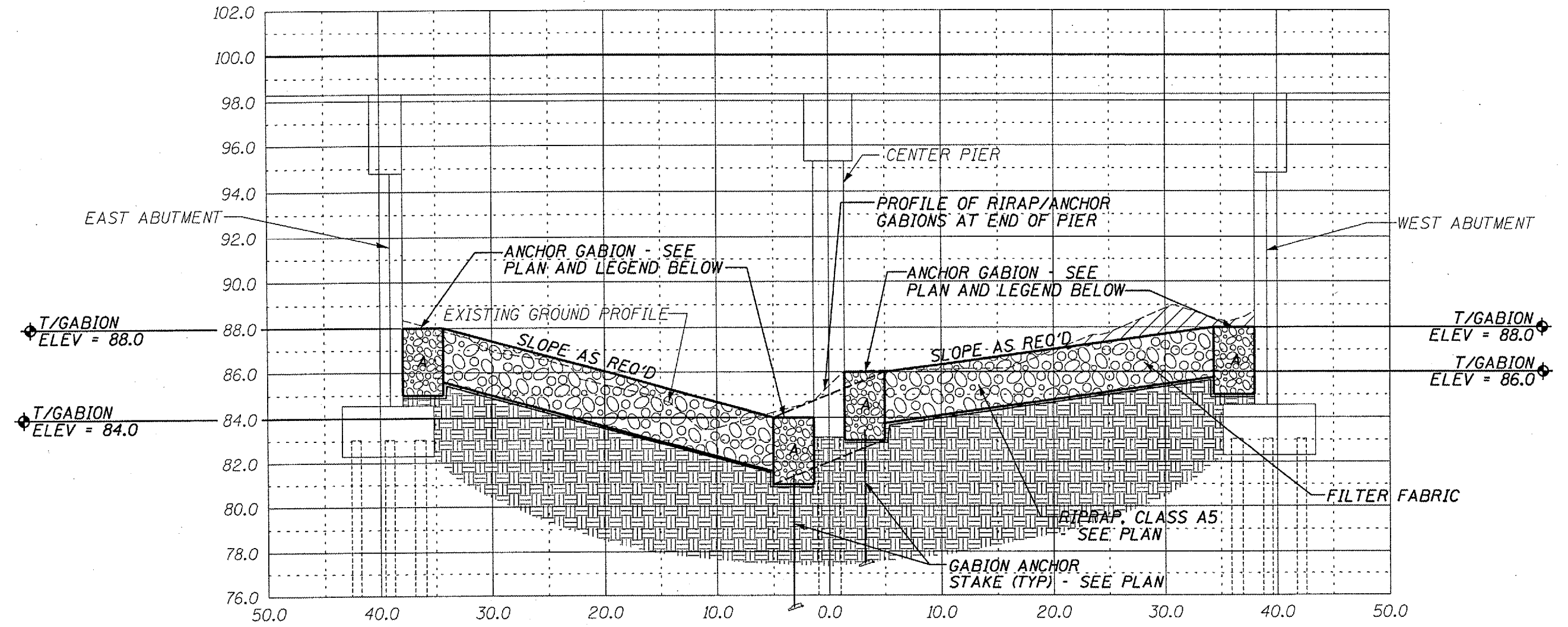

SECTION B-B THROUGH  $\phi$  OF F.A.P. 701

**REVISED**  
 7-21-06  
 SHEET

GABION LEGEND			
MARK	LENGTH	WIDTH	HEIGHT
A	6'	3'	3'

ILLINOIS DEPARTMENT OF TRANSPORTATION  
 SITE CROSS SECTION  
 S.N. 090-0058  
 F.A.P. 701 (IL 122) OVER  
 NORTH FORK SUGAR CREEK  
 TAZEWELL COUNTY  
 SHEET 7 OF 8  
 SCALE: VERT. 1" = 5' HORIZ. 1" = 10'

ROUTE NO.	SECTION	COUNTY	TOTAL SHEETS	SHEET NO.
F.A.P. 701	*	TAZEWELL	30	30
FED. ROAD DIST. NO. 4		ILLINOIS	FED. AID PROJECT	

\* (128BR)I-1

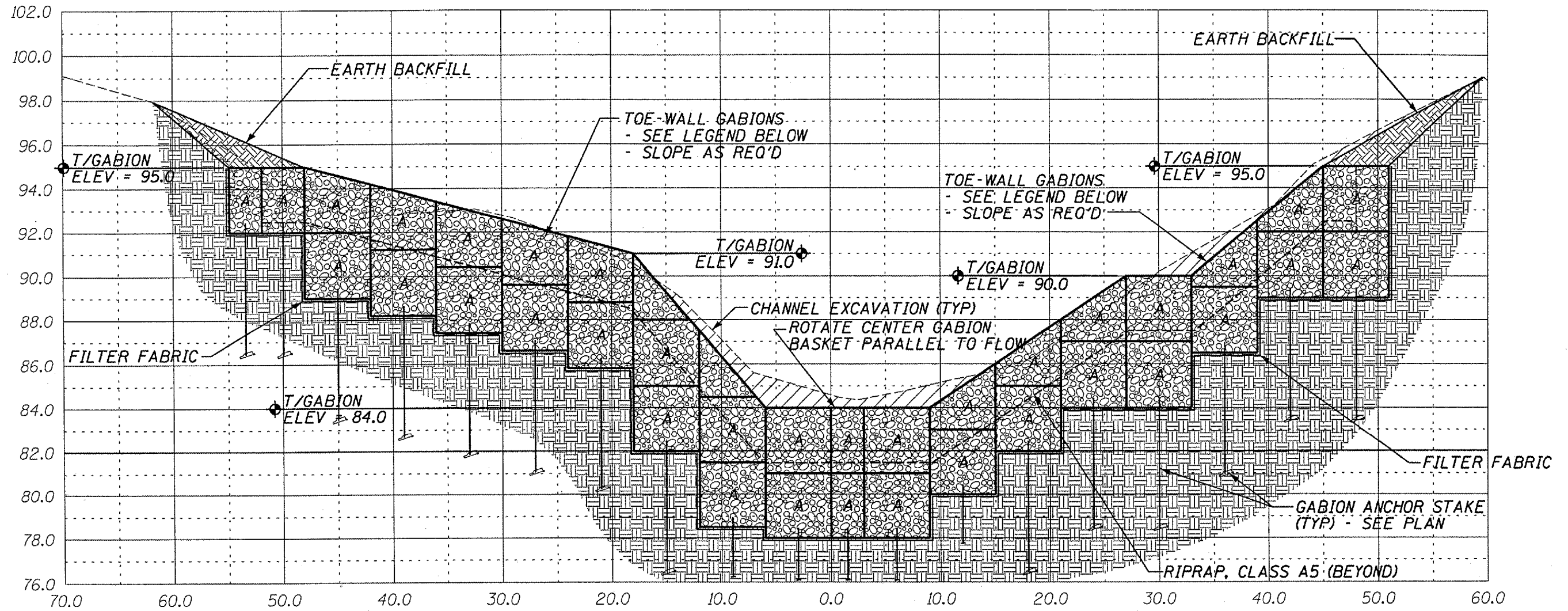

SECTION C-C THROUGH SOUTH GABION TOE-WALL

**REVISED**  
 7-21-06  
 SHEET

GABION LEGEND			
MARK	LENGTH	WIDTH	HEIGHT
A	6'	3'	3'

ILLINOIS DEPARTMENT OF TRANSPORTATION  
 SITE CROSS SECTION  
 S.N. 090-0058  
 F.A.P. 701 (IL 122) OVER  
 NORTH FORK SUGAR CREEK  
 TAZEWELL COUNTY  
 SHEET 8 OF 8  
 SCALE: VERT. 1" = 5' HORIZ. 1" = 10'

ROUTE NO.	SECTION	COUNTY	TOTAL SHEETS	SHEET NO.
F.A.P. 701	*	TAZEWELL	30	30A
FED. ROAD DIST. NO. 4		ILLINOIS	FED. AID PROJECT	

\*(128BR)I-1

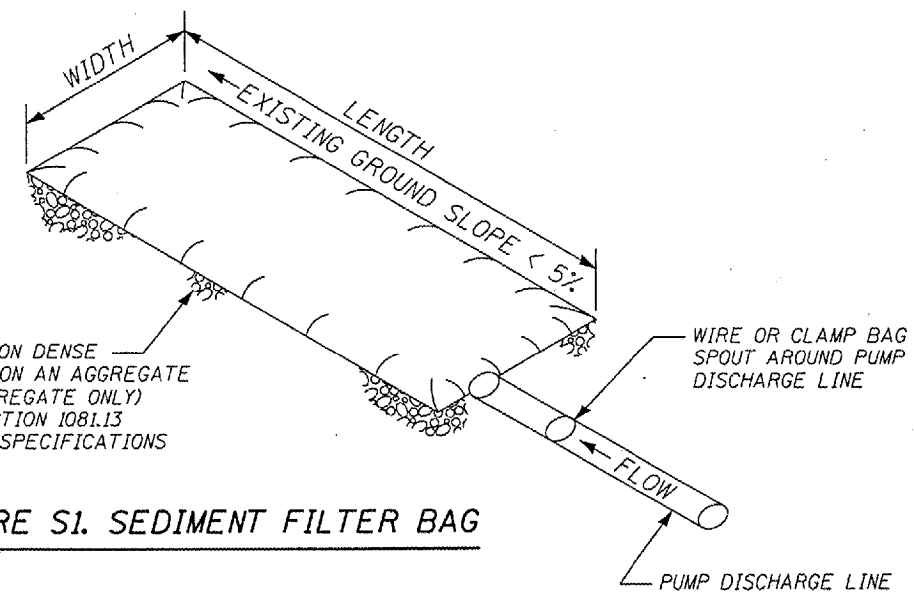

ENSURE THAT RUNOFF FROM THE BAG LOCATION IS PREVENTED FROM CAUSING EROSION BY GRASS, STONE, OR GEOTEXTILE LINING OF DISCHARGE CHANNEL.

REMOVE SILT WHEN BAG IS HALF FULL OR MORE OFTEN IF RECOMMENDED BY THE MANUFACTURER. DISPOSE OF SILT BY TRANSPORTING THE FILLED BAG TO DISPOSAL AREA. SLIT THE BAG, BLEND SILT INTO EXISTING TOPOGRAPHY, SEED AND MULCH

MAINTAIN EXTRA FILTER BAGS ON SITE. REPLACE DAMAGED BAGS PROMPTLY

TYPICAL FLOW RATE: 10 GPM x W x L

FIGURE S1. SEDIMENT FILTER BAG

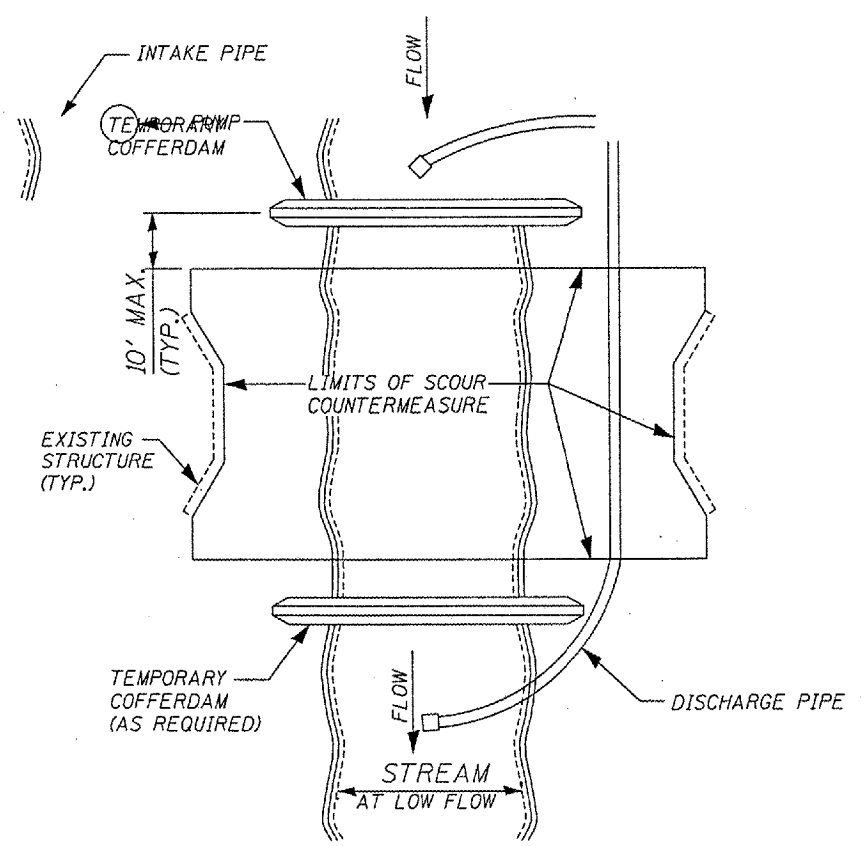

FIGURE D1. TEMPORARY COFFERDAM WITH PUMP BYPASS

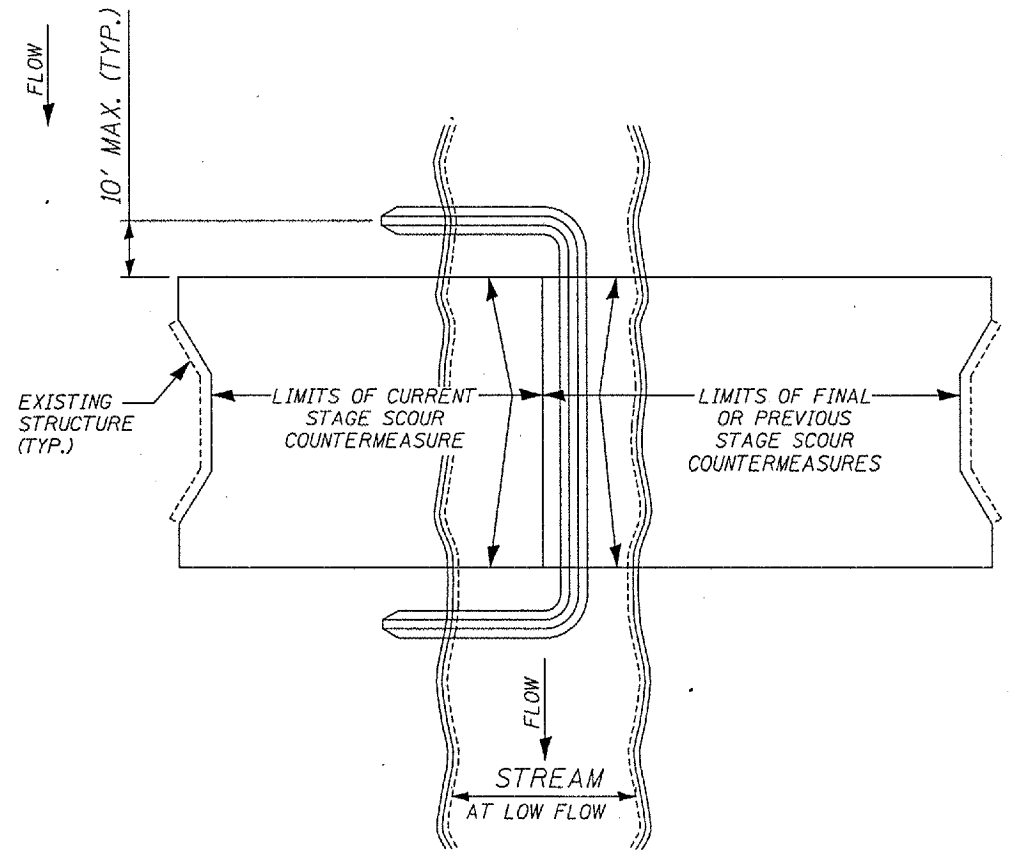

FIGURE D2. STAGED IN-STREAM COFFERDAM DIVISION

NOTE: DEWATERING SYSTEM DETAILS SHALL BE USED IN CONJUNCTION WITH THE PROJECT SPECIAL PROVISIONS.

**REVISED**  
7-21-06  
SHEET

ILLINOIS DEPARTMENT OF TRANSPORTATION  
DEWATERING SYSTEM DETAILS  
S.N. 090-0058  
IL 122 OVER SUGAR CREEK

# SUGGESTED INSTALLATION SEQUENCE

(SEE ALSO SECTION 284 OF THE STANDARD SPECIFICATIONS)

- INDIVIDUALLY ASSEMBLE THE EMPTY GABION BASKET UNITS.
- POSITION THE INITIAL LINE OF EMPTY GABION BASKET UNITS ON THE PREPARED SURFACE IN A DIRECTION PERPENDICULAR TO STREAM FLOW. SECURE ADJOINING BASKETS AND PARTIALLY FILL TO PROVIDE ANCHORAGE AGAINST DEFORMATION AND DISPLACEMENT DURING FILLING OPERATIONS.
- POSITION AND SECURE THE REMAINING EMPTY GABION BASKET UNITS ON THE PREPARED SURFACE AS SHOWN ON THE PLANS.
- PLACE THE BASKETS IN TENSION AND STRETCH TO REMOVE ANY KINKS FROM THE FABRIC. STRETCH THE EMPTY GABION BASKET UNITS IN A MANNER THAT WILL PREVENT UNRAVELING.
- FILL THE BASKET UNITS IN STAGES TO PREVENT LOCALIZED DEFORMATION. INTERNAL CONNECTING WIRES SHALL BE INSTALLED BETWEEN STONE LAYERS TO CONNECT THE FRONT FACE OF THE BASKET UNIT TO THE BACK FACE. AT NO TIME SHALL ANY CELL BE FILLED TO A DEPTH EXCEEDING 12 INCHES MORE THAN THE ADJOINING CELL. THE MAXIMUM HEIGHT FROM WHICH THE STONE MAY BE DROPPED INTO THE BASKET SHALL BE 3 FT.
- TIGHTLY STRETCH THE LID OVER THE STONE FILL USING A LID CLOSING TOOL APPROVED BY THE MANUFACTURER. USING CROWBARS OR OTHER SINGLE POINT LEVERAGE BARS FOR LID CLOSING SHALL BE PROHIBITED. TIGHTLY SECURE THE LID TO THE FILLED BASKET ALONG ALL EDGES, ENDS AND INTERNAL CELL DIAPHRAMS.
- IN LIEU OF FILLING BASKETS IN PLACE, THE BASKETS MAY BE PREFILLED ON A LEVEL SURFACE AS INDICATED IN STEPS 5 AND 6. THE BASKETS CAN THEN BE LIFTED AND PLACED ON THE PREPARED SURFACE USING A MANUFACTURER'S APPROVED LIFTING TECHNIQUE. CARE SHALL BE TAKEN NOT TO ABRASE THE ZINC OR VINYL COATING OR PERMANENTLY DISTORT THE SHAPE OF THE BASKET IN TRANSPORTATION. ANY DAMAGE TO THE BASKETS SHALL BE REPAIRED AT THE CONTRACTOR'S EXPENSE TO THE SATISFACTION OF THE ENGINEER. BASKETS SHALL BE PLACED TIGHTLY AGAINST AND SECURED TO BASKETS ALREADY IN PLACE.
- WHERE A COMPLETE GABION UNIT CANNOT BE INSTALLED AS SHOWN ON THE PLANS BECAUSE OF SPACE LIMITATIONS, THE BASKET UNIT SHALL BE CUT, FOLDED AND WIRED TOGETHER TO SUIT EXISTING SITE CONDITIONS.

FABRIC OPENING  
NOMINAL DIMENSIONS  
3 1/4" x 4 1/2"

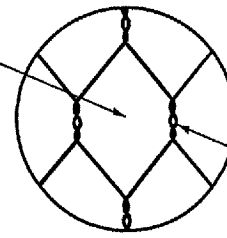

HEXAGONAL MESH  
FABRIC WITH AT LEAST  
THREE HALF TWISTS

### NOTES:

- GABION BASKETS SHALL BE CONSTRUCTED OF A GALVANIZED, ALUMINIZED, OR PVC-COATED GALVANIZED OR ALUMINIZED STEEL WIRE.
- STEEL WIRE SHALL CONFORM TO SECTION 1006.35 OF THE STANDARD SPECIFICATIONS

## GABION FABRIC DETAIL

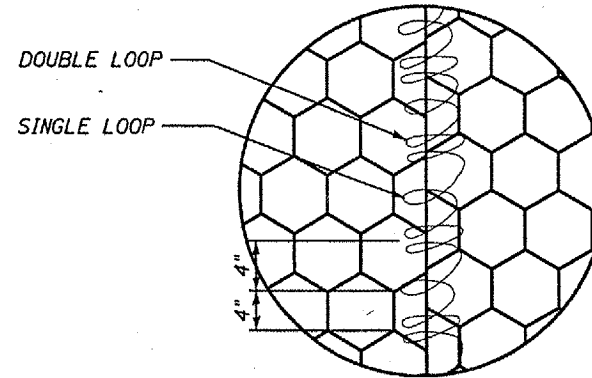

## LACING DETAIL

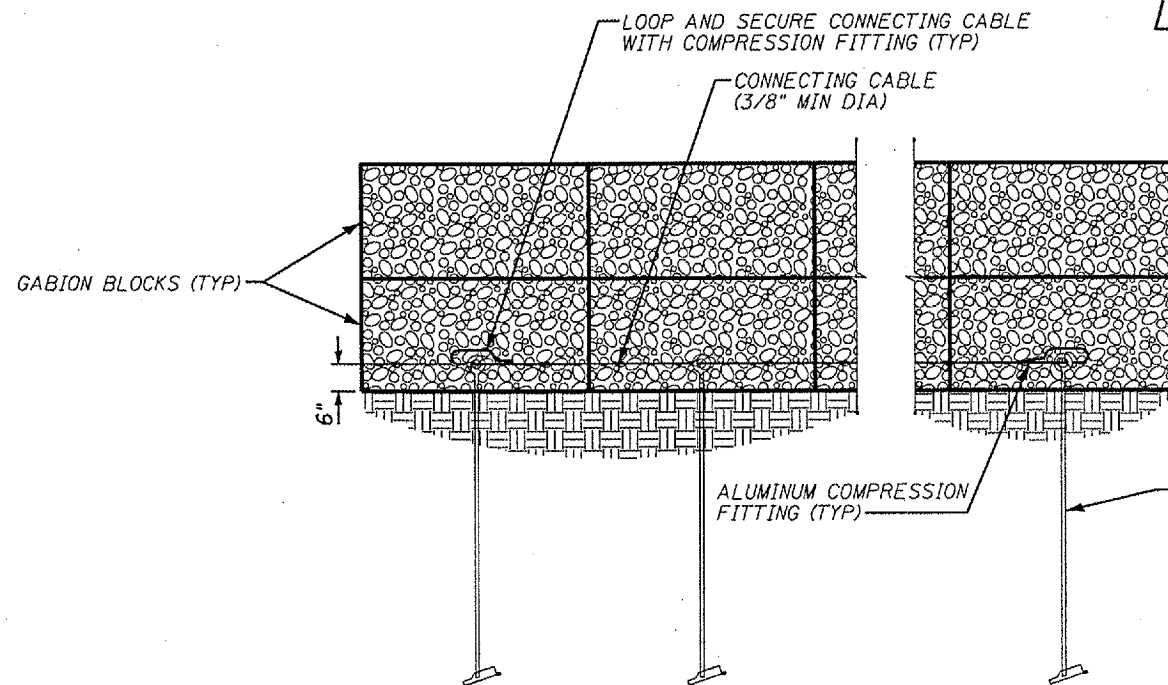

## GABION ANCHOR STAKE SECURING DETAIL

ROUTE NO.	SECTION	COUNTY	TOTAL SHEETS	SHEET NO.
F.A.P. 701	*	TAZEWELL	30	308
FED. ROAD DIST. NO. 4		ILLINOIS	FED. AID PROJECT	

\* (128BR)I-1

### GABION BASKET NOTES:

- BASKETS SHALL BE OF SINGLE UNIT CONSTRUCTION. THE BASE, LID, ENDS AND SIDES SHALL BE EITHER WOVEN INTO A SINGLE UNIT OR ONE EDGE OF THESE MEMBERS CONNECTED TO THE BASE SECTION OF THE BASKETS. FOR PROPER ASSEMBLAGE, SEE LACING DETAIL.
- DIAPHRAMS SHALL EQUALLY DIVIDE BASKETS WHERE THE LENGTH OF THE BASKET EXCEEDS 1 1/2 IT'S HORIZONTAL LENGTH.
- GABION BASKET ASSEMBLAGE, INSTALLATION, FILLING AND LID-CLOSING SHALL BE IN ACCORDANCE WITH SECTION 284 OF THE STANDARD SPECIFICATIONS.

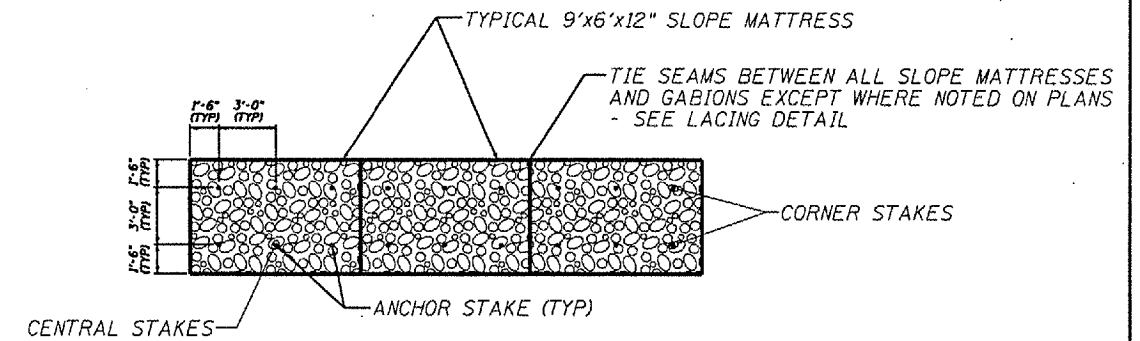

### NOTES:

- ANCHOR STAKES SHALL BE PROVIDED IN ACCORDANCE WITH SECTION 284 OF THE STANDARD SPECIFICATIONS.
- ANCHOR STAKES ARE TO BE PLACED ON THREE-FOOT CENTERS, WITH AN ARRANGEMENT AS SHOWN ABOVE, FOR ALL SLOPE MATRESSES LAID ON A SLOPE OF 2:1 OR GREATER.
- ANCHOR STAKES FOR SLOPE MATRESSES LAID ON SLOPE LESS THAN 2:1 AND GREATER THAN 10% SHALL OMIT THE CENTRAL STAKES SHOWN ABOVE - 4 STAKES PER 6'x9' MATRESS.
- ALL SLOPE MATRESSES LAID ON SLOPES LESS THAN 10% SHALL NOT HAVE ANCHOR STAKES.

## TYPICAL ANCHOR STAKE LAYOUT DETAIL

GABION LEGEND			
MARK	LENGTH	WIDTH	HEIGHT
A	6'	3'	3'
B	9'	3'	3'
C	12'	3'	3'
D	6'	3'	1 1/2'
G	6'	3'	1'
H	9'	3'	1'

**REVISED**  
7-21-06  
SHEET

ILLINOIS DEPARTMENT OF TRANSPORTATION

GABION DETAILS  
S.N. 090-0058  
IL 122 OVER SUGAR CREEK