

ROUTE NO.	SECTION	COUNTY	TOTAL SHEETS	SHEET NO.
T.R. 133	05-17117-00-BR	SHELBY	21	9
ROAD DIST.	ILLINOIS	RIDGE		

CONTRACT NO. 95484

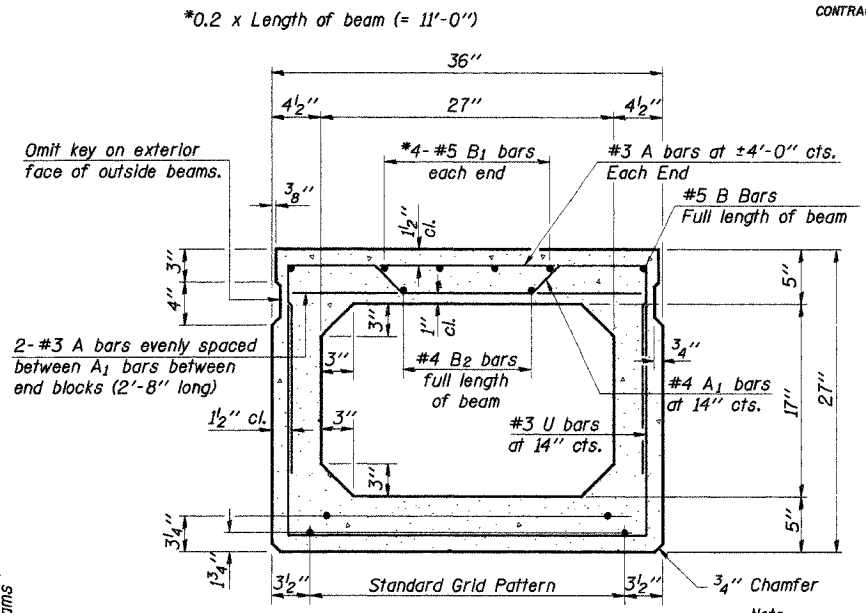
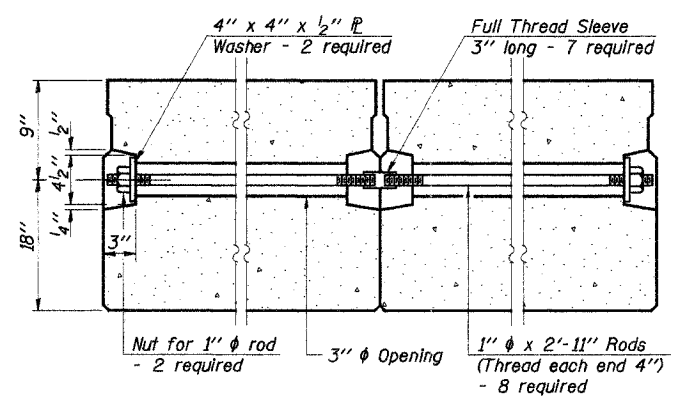
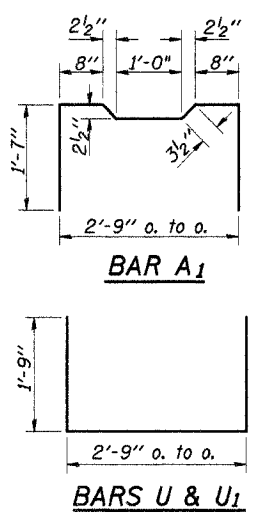
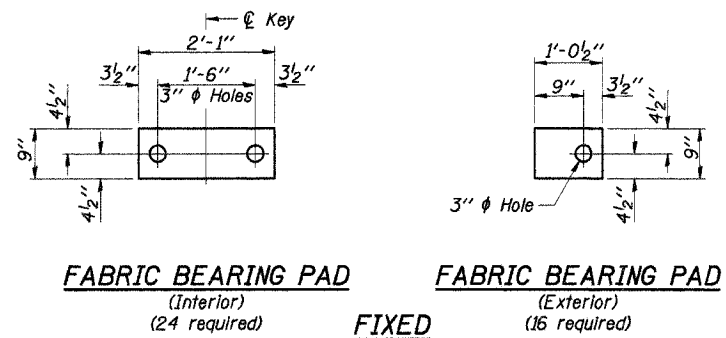

Note: Place strands symmetrically about  $\bar{c}$  of beam.

12- $\frac{1}{2}$ "  $\phi$  Strands Each Strand Stressed to 30,900 Lbs.  
8-Strands 1 $\frac{3}{4}$ " up, 4-Strands 3 $\frac{1}{4}$ " up

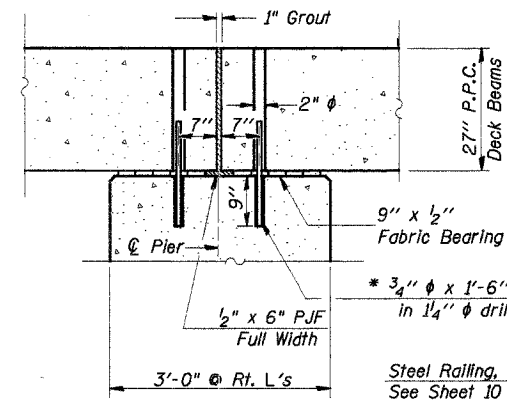
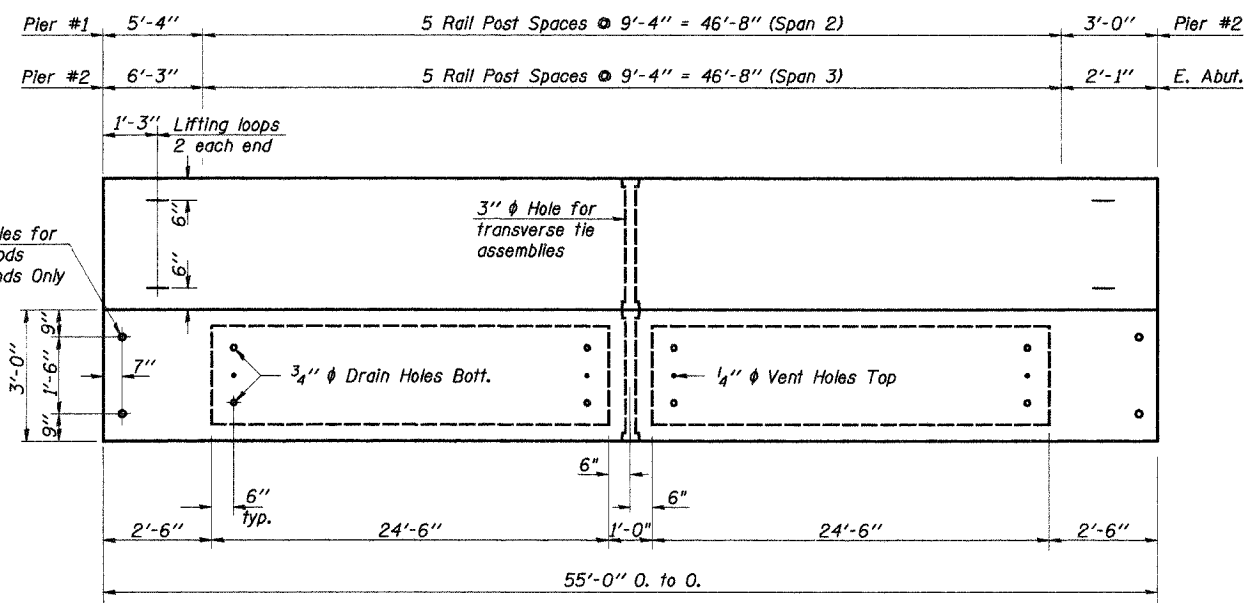

\* Note: After beams are in place, 1 $\frac{1}{4}$ " holes shall be drilled into the Substructure, and the dowel rods grouted in place and allowed to cure (Min. 24 Hrs.) prior to grouting shear key.

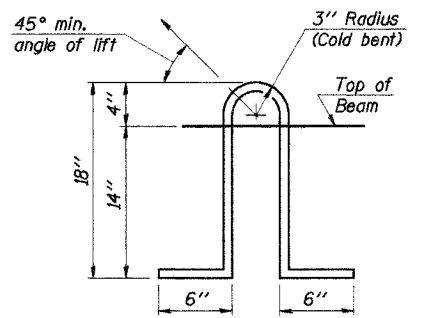
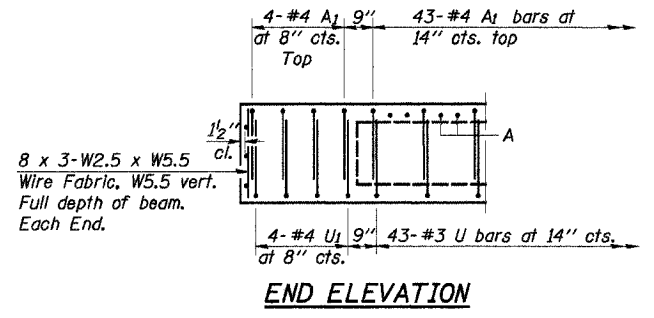
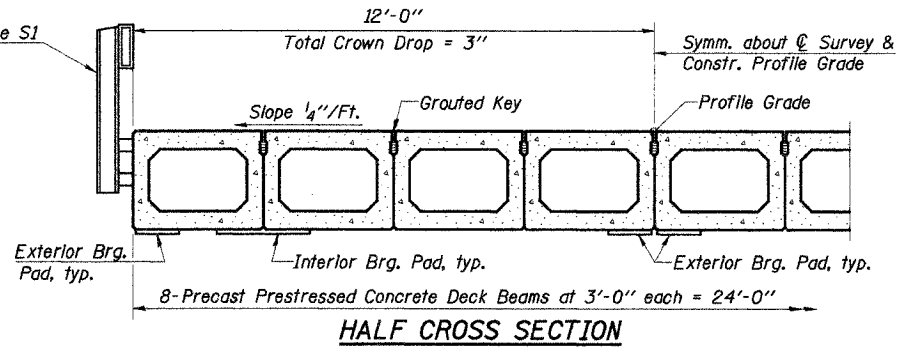

**NOTES**

Prestressing steel shall be uncoated high strength, low relaxation 7-wire strand, Grade 270. The nominal diameter shall be  $\frac{1}{2}$ " and the nominal cross-sectional area shall be 0.153 sq. in. Lifting loops shall be 2- $\frac{1}{2}$ "  $\phi$  270 ksi strands, as shown. The 1"  $\phi$  rods in the transverse tie assembly shall be tightened to a snug fit and the threads set. Pockets that receive transverse tie bar on outside shall be filled with grout after transverse tie assembly is in place. The bearing seat surfaces shall be adjusted by shimming to assure firm and even bearing. Two  $\frac{1}{8}$ " fabric adjusting shims of the dimensions of the Exterior Bearing Pad shall be provided for each bearing. (80 Req'd) Keyway surfaces shall be cleaned to remove form oil or other bond breaking material prior to shipment of the beams. Cleaning shall be done by sandblasting the keyway areas between top of the beam and the bottom edge of the key. Required Release Strength, 1'ci, shall be 4,000 p.s.i. See Special Provisions for review and distribution of shop drawings.

**BILL OF MATERIAL**

Item	Unit	Quantity
Precast Prestressed Concrete Deck Beams (27" Depth)	Sq. Ft.	2,640

Estimated Total Weight (One Beam) = 33,990 Pounds

DESIGNED	F.J.S.
CHECKED	A.R.K.
DRAWN	S.A.P.
CHECKED	A.R.K. & F.J.S.

PD-5-S 9-1-03

**SUPERSTRUCTURE - SPANS 2 & 3**

SECTION 05-17117-00-BR  
RIDGE ROAD DISTRICT  
SHELBY COUNTY  
STATION 15+02.38

4440 ASH GROVE  
SPRINGFIELD, IL 62711  
(217) 793-8600  
oasinc@insightbb.com

**OZYURT AND STONE, INC.**  
CONSULTING ENGINEERS

JOB NO.: 0504  
FILE: 0504SUPER2.DGN  
DATE: 02/14/06